

S Pro Laser Projector

User Manual

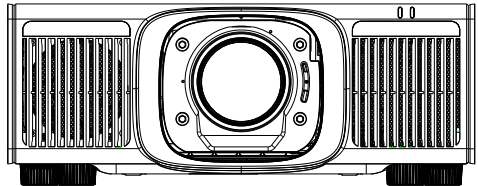

- Please read this manual carefully before using this product and keep it for future reference.
- Please read "Important Safety Instructions" carefully before using this product.

Declaration

Copyright

Appotronics Corporation Ltd. reserves all rights. No part of this document may be reproduced, transmitted, translated or stored in a retrieval system or translated into any text or computer language in any form or by any means, including electronic, mechanical, magnetic, optical, chemical, handwritten or otherwise, without the prior written permission of Appotronics.

All trademarks and registered trademarks are the property of their respective owners.

Disclaimer

Appotronics does not make any express or implied representations or warranties with respect to any of the contents of this manual, and does not provide any warranties with respect to merchantability or fitness for a particular purpose. In addition, the company reserves the right to revise this publication and to modify the contents of this document at any time without notice to anyone.

Repair

Under normal use and storage conditions, Appotronics provides warranty on any materials and process defects of this product. Proof of purchase date must be provided when you require the warranty service. If any product defect is found during the warranty period, the sole obligation of Appotronics and the exclusive remedy are to replace the defective parts (including the service charge). When you find that the product is defective, please immediately notify the dealer to obtain the warranty service.

Important: If the customer fails to use the product in accordance with the written instructions, the above warranty will not apply. Ensure that the ambient humidity is between 10% and 90%, the ambient temperature is between 0°C and 40°C and the altitude is below 5000m. Avoid using the product in a dusty environment.



This symbol warns users that the uninsulated voltage in the projector may be sufficient to cause an electric shock. Therefore, there is a risk of electric shock due to any contact with any component inside the projector.



This symbol alerts users to notice important information about the operation and maintenance. Please read this information carefully to avoid problems.

WARNING: Operating this device in a residential environment may cause radio interference.

Contents

Declaration	2	Picture Adjustment	35
Contents	3	Color Adjustment	43
Safety Instructions.....	4	Aspect Ratio	45
General Safety Instructions	4	Geometric Correction	45
Important Safety Instructions	5	Edge Blending	47
Laser Safety	12	Projector Installation	50
Overview	17	Projection Menu	50
Disclaimer	17	Lens Adjustment	51
Installation Requirements	17	Projector ID	53
Packaging Overview	18	Remote C. Reception	54
Projector Appearance	19	Mechanical Shutter	55
Remote Control	24	Settings	55
Replacing Remote C. Battery	26	Projector Signal	62
Installation	27	Signal	62
Lens Replacement	27	3D Settings	64
Lens Removal	27	Projection Information	65
Lens Installation	27	Information Display	65
Projector Connection	28	Appendix	66
Turning on/off the Projector	29	Compatible Signal List	66
Adjusting the Projected Image	30	3D Compatible Signal List	67
Ceiling Installation	32	Troubleshooting	68
Cooling Duct and Airflow Description	33	Fault Diagnosis	68
Projected Image	34	Indicator Lights	69
Projector Menu	35	Maintenance and Repair Services	70
		Overall Dimensions	71

Safety

General Safety Instructions

- ◆ Please read this manual carefully before using this product and keep it for future reference.
- ◆ The device shall be installed by an authorized qualified technical professional.
- ◆ Operation and maintenance should be performed by qualified professionals authorized by the company in restricted areas.
- ◆ All warnings listed on this projector and listed in this manual shall be observed.
- ◆ Please strictly observe all instructions on operations and usage.
- ◆ Please strictly observe all local installation standards.
- ◆ This equipment is not suitable for use in places where children may be present.

This equipment complies with safety standards stipulated for information technology equipment that are subject to stringent requirements for the use of critical safety assemblies, components, materials, and insulators in order to protect users and operators from the following hazards:

- Electric shock
- Energy-related hazards
- Fire
- Heat-related hazards
- Mechanical hazards
- Radiation
- Chemical hazards

Terms:

- ◆ Professionals:
Professionals are personnel with appropriate technical training and practical experience who understand the potential hazards involved in performing installation and maintenance tasks and what measures should be taken to minimize these potential hazards.
- ◆ Users:
Refer to all personnel other than professionals.
- ◆ Restricted Access Areas:
Only professionals can enter the restricted access area or only if a user is aware of the reasons for restricting access to the area and has taken preventive measures. The operator must use a specific tool, lock, or key or take other safety measures to access the areas. In addition, the access to the areas is controlled by the specified agency who is in charge of the area.

Safety

Important Safety Instructions

■ General safety instructions

- ◆ Before operating this equipment please read this manual thoroughly and retain it for future reference.
- ◆ Installation and preliminary adjustments should be performed by qualified APPOTRONICS personnel or by authorized APPOTRONICS service dealers.
- ◆ All warnings on the projector and in the documentation manuals should be adhered to.
- ◆ All instructions for operating and use of this equipment must be followed precisely.
- ◆ All local installation codes should be adhered to.

■ Notice on optical radiation

- ◆ This projector embeds extremely high brightness (radiance) lasers; this laser light is processed through the projector's optical path. Native Laser light is not accessible by the end user in any use case. The light exiting the projection lens has been diffused within the optical path, representing a larger source and lower radiance value than native laser light. Nevertheless the projected light represents a significant risk for the human eye and skin when exposed directly within the beam. This risk is not specifically related to the characteristics of laser light but solely to the high thermal induced energy of the light source; which is equivalent with lamp based systems.
- ◆ Thermal retinal eye injury is possible when exposed within the Hazard Distance (HD), Hazard Distance (HD), distance from the projector's nearest point of human access, where the beam radiance or irradiance exceeds the applicable exposure limit.



WARNING: No direct exposure to the beam shall be permitted, RG3 IEC 62471-5:2015.



CAUTION: Use of controls or adjustments or performance of procedures other than those specified herein may result in hazardous radiation exposure.



WARNING: Operators shall control access to the beam within the hazard distance or install the product at the height that will prevent exposures of spectators' eyes within the hazard distance.

■ Restricted access location

- ◆ This product may only be installed in a restricted access location. The definition of a "restricted access location" is a location for equipment where both of following applies:

- ◆ Access can only be gained by SERVICE PERSONNEL or by OPERATORS who have been instructed about the reasons for the restriction applied to the location and about the precautions that shall be taken.
- ◆ Access is through the use of the tool or lock and key, or other means of security, and is controlled by the authority responsible for the location.
- ◆ This is a RG3 product, Based on interational requirements, no person is allowed to enter the projected beam within the zone between the projection lens and the related Hazard Distance (HD). This shall be physically impossible by creating sufficient separation height or by placing optional barriers. Within the restricted area operator training is considered sufficient, The applicable separation heights are discussed in "High Brightness precautions: Hazard Distance".
- ◆ The terms SERVICE PERSONNEL and TRAINED PROJECTIONIST refers to persons having appropriate technical training and experience necessary to be knowledgeable of potential hazards to which they are exposed (including, but not limited to HIGH VOLTAGE ELECTRIC and ELECTRONIC CIRCUITRY and HIGH BRIGHTNESS PROJECTORS) in performing a task, and of measures to minimize the potential risk to themselves or other persons. The term USER and OPERATOR refers to any person other than SERVICE PERSONNEL or TRAINED PROJECTIONISTS, AUTHORIZED to operate professional projection systems.
- ◆ The projectors are intended "FOR PROFESSIONAL USE ONLY" by AUTHORIZED PERSONNEL familiar with potential hazards associated with high voltage, high intensity light beams generated by lasers. Only qualified SERVICE PERSONNEL and TRAINED PROJECTIONISTS, knowledgeable of such risks, are allowed to perform service functions inside the product enclosure.

■ Preventing the risk of electric shock

- ◆ The projector should use AC power. Make sure that the main voltage and capacitance match the rated power of the projector. If the installation environment cannot meet the AC power requirements, please contact the electrician.
- ◆ The connector is used as a disconnect device and the product should not be installed far from the disconnect device so that the power can be disconnected in time.
- ◆ The installation can only be carried out by qualified technical personnel in accordance with local electrical codes and regulations.
- ◆ This device uses a three-terminal power cable that includes a single-phase line that protects the ground wire (PE). If the installation environment cannot meet the AC power requirements, please contact the electrician. Please do not ignore the role of PE.
- ◆ Turn off the power to the projector and unplug the power cord to cut off all power connections from the projector.

- ◆ If you need to extend the cable, use a power cable with the current rated value not lower than that of the projector. If the rated value of the power cable is lower than the current value of the projector, it may cause overheating.
- ◆ Do not disassemble the projector. When it needs to be maintained or repaired, hand it over to a trained and authorized service person.
- ◆ Do not spill any liquid on the projector.
- ◆ To better protect the product during thunderstorms or when it is not used for a long period of time, unplug the power plug from the wall socket. This will prevent lightning or power line surges from causing damage to the projector.
- ◆ The connector must be connected well before turn on the power.
- ◆ Wiring methods used for the connection of the equipment to the mains supply shall be in accordance with standards IEC/EN/UL 62368-1, the National Electrical Code, NFPA 70, and the Canadian Electrical Code, Part I, CSA C22.1.
- ◆ The power cord shall have conductors with cross-sectional areas sufficient for the rated current of the projector.

■ Preventing personal injury

- ◆ To prevent personal injury and physical damage, refer to this manual and all the labels on the system before plugging the power plug into the electrical outlet, or commissioning the projector.
- ◆ To prevent injury, ensure that the lens and all covers are installed correctly.
- ◆ Before attempting to move or remove the projector, turn off the projector and unplug the power plug from the wall socket.
- ◆ When you need to turn off the projector to access internal parts, you must disconnect the power cable from the power supply and unplug the power cable from the UPS power input socket (authorized maintenance personnel only). If the projector's power input is not accessible (for example, in ceiling-mounted installation mode), install a common disconnect device that is easily accessible in the fixed wiring.
- ◆ Warning: High intensity light. Do not look into the lens! High brightness will cause damage to the eyes. Never look at the end of the laser beam while the equipment is in operation. Laser radiation is harmful to the human eye and injury may occur.
- ◆ The laser has high density energy. These may be dangerous for skin tissue and may cause electrical, and chemical and non-ionizing radiation hazards.
- ◆ Warning: Running this device in a residential environment may cause radio interference.

Safety

■ Preventing battery explosion

- ◆ If the battery is improperly installed, an explosion may occur.
- ◆ Replace the battery with the manufacturer's recommended or equivalent type of battery
- ◆ When disposing used batteries, be sure to refer to the rules and regulations on disposal of hazardous wastes at the national, provincial and local levels to ensure proper disposal of waste.

■ Preventing fire

- ◆ The design and manufacture of the projector conforms to the most stringent safety requirements. Putting the flammable material near the projector may cause the material to ignite itself, causing a fire. Once fire occurs, be sure to use sand, CO₂ or dry powder fire extinguishers. Please do not use water to extinguish a fire when an electrical fire occurs.
- ◆ It is advisable to leave a "quarantine" around all the outer surfaces of the projector. No flammable material shall be placed in this area. Do not use any material to cover the projector or lens while the projector is working.
- ◆ Do not block the vents around the projector. Do not place paper or other objects in the range of 50cm (20 inches) around the projector.
- ◆ The slots on the projector are used for ventilation and heat dissipation. To ensure reliable operation of the projector and to prevent it from overheating, do not block or cover these slots. The distance between the projector and the wall or other similar surface should be greater than 50cm (20 inches). The projector should not be put close to a wall or other similar surface. The projector should not be placed near the radiator or heat regulator. Unless the ventilation is good, the projector should not be placed in the embedded device or enclosed device.
- ◆ The projection room must be well ventilated or have a cooling device to avoid heat buildup. The hot air discharged from the projector must be able to be discharged to the outside of the building.
- ◆ If the projector is not used for a long period of time, remove the power cable.

■ Preventing damages to the projector

- ◆ When using the projector, be sure to open the lens shutter or remove the lens cover.
- ◆ If there is any abnormality in the projector, unplug the power cable immediately. Do not continue to use the projector when it comes to smoke or makes strange noise or odor. In this case, immediately unplug the power cable and then contact the dealer.
- ◆ Please keep the original shipping box and packing material which can be used again to transport the equipment. In order to maximize the protection of the equipment, re-package it in accordance with the original packaging at the factory.

Safety

- ◆ Before cleaning the equipment, please unplug the power plug from the electrical outlet. Do not use cleaners or spray cleaners, but use a damp cloth for cleaning. Do not use irritating solvents, such as thinners, gasoline, or corrosive cleaners, as they can cause damage to the case. You can use a damp cloth and a mild detergent to remove stubborn stains.
- ◆ To ensure maximum optical performance and resolution, the projection lens is coated with a special anti-reflective coating, so avoid touching the lens. If you need to remove dust from the lens, gently wipe the lens surface with wipe paper or a dust-free cloth with a small amount of alcohol, rather than using a damp cloth, cleaner or thinner.
- ◆ Do not place this projector on an unstable vehicle, shelf or table. Because it will cause serious damage once the projector is dropped. Functions may be affected. Therefore, you should replace them. For example, damages such as cracks or deep scratches may occur.

■ Means of radiation protection

- ◆ All laser products, systems, shows, and projectors will be certified to comply with 21 CFR 1040.10 and the conditions of this variance and will be reported as required by 21 CFR 1002.10 AND 1002.11 using the reporting guides provided for such purpose. These actions will be accomplished prior to any introduction into commerce.
- ◆ Effects not specifically indicated in this variance application will not be performed, No other effects will be added until an amendment to the variance has been obtained and the required reports or supplements, as applicable, have been submitted.
- ◆ Projection of laser and collateral radiation (Light show radiation) into audience or other accessible uncontrolled areas will not be permitted except for diffuse reflections produced by the atmosphere, added atmospheric scattering media, and target screens.
- ◆ Laser radiation levels in excess of the limits of Class I will not be permitted at any point less than 3.0 meters above any surface upon which persons other than operators, performers, or employees are permitted to stand or 2.5 meters below or in lateral separation from any place where such persons are permitted to be. Operators, performers, and employees will not be required or allowed to view radiation above the limits of Class I or be exposed to radiation above the limits specified in 21 CFR 1040.11(c).
- ◆ All laser light shows shall be under the direct and personal control of trained, competent operator(s). The operator(s) will:
 - (1) Be an employee of the variance holder who will be responsible for the training and the conduct of the operator;
 - (2) Be located where all beam paths can be directly observed at all times;
 - (3) Immediately terminate the emission of light show radiation in the event of any unsafe condition; or, for outdoor shows, upon request by any air traffic control officials.

- ◆ The maximum laser projector output power will not exceed the level required to obtain the intended effects.
- ◆ The projection system (i.e., the projector and all other components used to produce the lighting effects) will be securely mounted or immobilized to prevent unintended movement or misalignment, Beam masking will be provided as an inherent part of the system design to prevent overfilling of screens, beam stops, targets, etc.
- ◆ All customers under an agreement of sale, lease, or loan should apply for and obtain a variance from CDRH prior to introduction such projector(s) into commerce of any laser light shows. Laser light show variance for RG3 LIPs can be requested by mailing the application to RadHealthCustomerService@fda.hhs.gov.
- ◆ Laser radiation areas which can contain radiation levels above the limits specified in 21 CFR 1040.11(c) will be clearly identified by the posting of warning signs and/or restricting access through physical means (such as pressure switches, photo cells, barriers, guards, etc.). These requirements apply to temporary areas (such as during set up and alignment procedures) and to final or permanent areas.

■ About Repair

- ◆ Do not service this equipment privately because opening or removing the cover may expose you to high pressure and face an electric shock hazard.
- ◆ If you attempt to change the internal control functions set at the factory or to change other control settings that are not specifically addressed in this manual, it will cause permanent damage to the laser light source suite and warranty failure.
- ◆ When the following cases occur, unplug the device from the electrical outlet and allow qualified service personnel to service:
 - The power cable or power plug is damaged or worn out.
 - Liquid enters into the equipment.
 - The equipment is exposed to rain or water.
 - If the equipment cannot operate properly in accordance with the operation instructions, adjust only the adjustment apparatuses mentioned in the operation instructions because improper adjustment of other apparatuses may cause equipment damage.
 - The equipment falls to the ground or the housing is damaged.
 - If the equipment performance deteriorates significantly, ask the maintenance personnel for help.
- ◆ Replacement parts: When using replacement parts, ensure that the service technician uses approved replacement parts or approved replacement parts that are identical to the original parts. Unauthorized alternatives may result in deteriorated performance and stability, causing fire, electric shock, or other hazards. Unapproved alternatives may void the warranty.

Safety

- The following warning symbols should be noted by maintenance personnel as they may cause a hazard during maintenance. A fuse is used on the center line of the equipment, and the equipment may still have energized parts after the fuse has been activated.

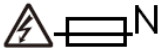

- Safety check: At the end of the projector's service, it is important to have the technical service personnel perform a safety check to ensure that the equipment has been returned to normal operating condition.

Safety

Laser Warning Label

Label	Description
	<p>Do not look into the beam. Ne regardez pas dans le faisceau. No direct eye exposure to the beam is permitted. Aucune exposition directe des yeux au faisceau n'est autorisée. Hazard Distance: Refer to the manual. Distance de danger: Reportez-vous au manuel.</p>
	CAUTION: Be careful of Hazard RG3.
	Class 1 laser product
	Hazard RG3: optical radiation warning symbol
	Hazard RG3: not for household use symbol
	<p>APPOTRONICS® LASER PROJECTOR</p> <p>Model: AL-SK20KAP AC Input: 100-240V~, 16-9A, 50-60Hz Manufacturer: Appotronics Co., Ltd. Address: 20F to 22F, High-Tech Zone Union Tower, No.63 Xuefu Road, Nanshan District, Shenzhen, Guangdong, P. R. China Importer: Appotronics USA Inc. Address: 2828 North Harwood Street, Suite 1800 Dallas, TX 75201</p> <p>WARNING: This product is in conformity with performance standards for laser products under 21 CFR 109.1, except with respect to those characteristics authorized by Variance Number FDA-xxxxxx-xxxx effective on xxxxx xx, xxxxx. Mfg. date: ~, xxxxxxxx. Made in China</p> <p>UL FCC CE </p> <p>Intertek 5012639 Conforms to UL Std. 62368-1 Certified to CSA Std. C22.2 No. 62368-1</p> <p>This device complies with Part 15 of the FCC Rules. Operation is subject to the following two conditions: (1) this device may not cause harmful interference, and (2) this device must accept any interference received, including interference that may cause undesired operation.</p> <p>Complies with 21 CFR 1040.10 and 1040.11 except for conformance as a Risk Group 3 LIP as defined in IEC 62471-5:Ed. 1.0. For more information see Laser Notice No. 57, dated May 8, 2019.</p>

Label location

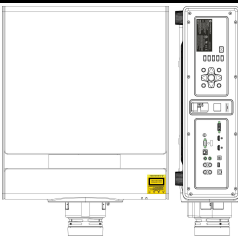

Safety

Laser Safety

Hazardous distance (HD) is the distance from the lens of the projection system to the surface of the projected beam when the unit energy reaches the exposure limit on the cornea of the eye or the skin of a person, and the distance of a person from the surface of the projected lens shall not be less than the HD. The area exceeding the exposure limit is the hazardous zone (HZ). If a person is inside the hazardous zone, it is considered unsafe, and there is a risk of injury to the eyes or skin from the beam. If a person is outside the hazardous zone, it is considered safe unless the person is intentionally staring at the beam of light projected by the projector.

The HD depends on the amount of lumens produced by the projector and the type of lens installed.

The HD depends on the amount of lumens produced by the projector and the type of lens installed, Laser radiation levels in excess of the limits of Class I will not be permitted at any point less than 3,0 meters above any surface upon which persons other than operators, performers, or employees are permitted to stand or 2,5 meters below or in lateral separation from any place where such persons are permitted to be, Operators, performers, and employees will not be required or allowed to view radiation above the limits of Class I or be exposed to radiation above the limits specified in 21 CFR 1040.11(c).

These values are minimum values and are based on the guidance provided in EC 62471-5:2015 section 6,6,3.5. The installer and user must understand the risk and apply protective measures based upon the hazard distance as indicated on the label and in the user information, Installation method, separation height, barriers, detection system or other applicable control measure shall prevent hazardous eye access to the radiation within the hazard distance.

Based on international requirements, no person is allowed to enter the projected beam within the zone between the projection lens and the related hazard distance (HD).

Install one or more readily accessible controls to immediately terminate the projection light, The power input at the projector side is considered as a reliable disconnect device, When required to switch off the projector. disconnect the power cord at the projector side. In case the power input at the projector side is not accessible (e.g. truss mount), the socket outlet supplying the projector shall be installed nearby the projector and be easily accessible, or a readily accessible general disconnect device shall be incorporated in the fixed wiring.

To protect untrained end users(as visitors, spectators) the installation shall comply with the following installation requirements: Operators shall control access to the beam within the hazard distance or install the product at the height that will prevent spectators' eyes from being in the hazard distance.

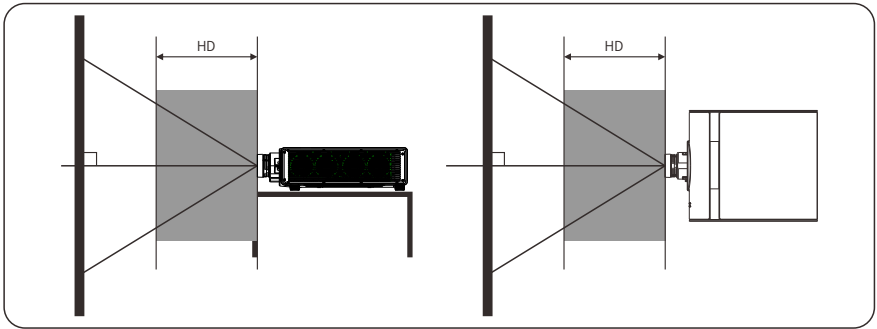

HD in function of modifying optics

Hazard Distance.

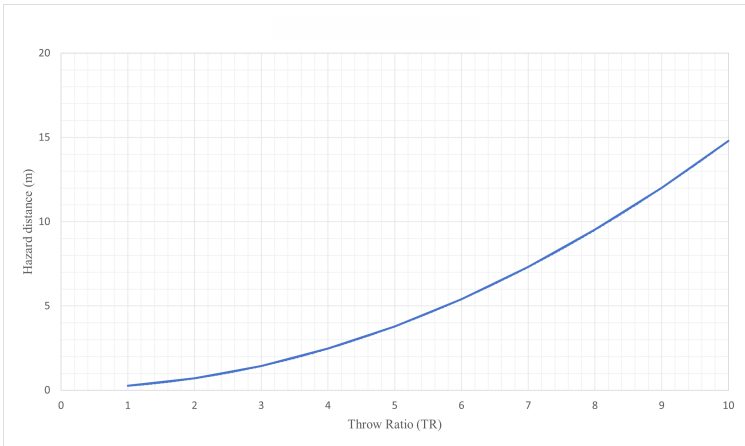

◆ Correspondence of Max. TR and HD

Lens Model	Max. TR	HD (m)
AL-XL150MA	2.4	0.96
AL-XL126MA	1.68	0.53
AL-XL169MA	2.42	0.98
AL-XL243LA	3.65	1.07

Throw ratio TR	Hazard distance HD(m)
1	0.34
2	1.1
3	2.4
4	4.1
5	6.4
6	9.2
7	12.2
8	16
9	20.2
10	25

Safety

A computation example of HD.

The maximum throw ratio $N_{TR} = 10$

The aspect ratio $N_{AS} = 1.6$

The apparent source size of a projector is 30 mm in diameter.

The distance between the outer surface of the lens and the aperture: $l_b = 120\text{mm}$

Assumes:

The spectral weighting functions are 1,0 for visible wavelength.

The luminous efficacy of radiation is 290 lm/W.

The optical emission is CW from a homogeneous source.

Angular subtense α of the source at a measurement distance of 1 m is

$$\alpha = 0.03 / (0.12 + 1) = 0.0268 \text{ rad}$$

The solid angle subtended by α is

$$\Omega = \pi (0.0268)^2 / 4 = 5.6 \times 10^{-4} \text{ sr}$$

Illumination area is $0.1 \times 0.06 \text{ m}^2$ at 1 m from the aperture of the projector.

The radiant power $P(W)$ passing through the above illumination area is

$$P = 30000 / 290 = 103.4 \text{ W}$$

The irradiance E at 1 m distance from the outer surface of the lens is then

$$E = 103.4 / (0.1 \cdot 0.06) = 17233 \text{ W/m}^2$$

Therefore,

$$L = E / \Omega = 2.94 \times 10^7 \text{ W/m}^2/\text{sr}$$

Safety

Retinal thermal hazard

The emission limit of retinal thermal hazard L_R is obtained from Table 3.

$$L_R \text{ for RG2} = 28000/\alpha = 1.05 \times 10^6 \text{ W/m}^2/\text{sr}$$

L is greater than L_R , therefore the projector is classified as RG3.

Calculation of hazard distance (HD)

$$L = E / \Omega$$

$E = P / S$, where S is projection area;

$$S = (l / N_{TR}) N_{AS} (l / N_{TR})$$

$$\Omega = \pi \alpha^2 / 4$$

Assume: the apparent source size of a projector d_S is not changed at the position of HD,

$$\Omega = \pi d_S^2 / 4l^2$$

$$L = 4 \cdot P \cdot N_{TR}^2 / (N_{AS} \pi \cdot d_S^2)$$

$$L_R \text{ for RG2} = 28000/\alpha = 28000 l_{HD} / d_S$$

where

l_{HD} is the distance between the source and the RG2 position:

$$l_{HD} = 4 P N_{TR}^2 / (28000 N_{AS} \pi \cdot d_S)$$

$$P = 103,4 \text{ w}$$

$$N_{TR} = 10$$

$$N_{AS} = 0.625$$

$$d_S = 0.03 \text{ m}$$

$$l_{HD} = 25.12$$

$$HD = 25.12 - 0.12 = 25 \text{ m}$$

Overview

Disclaimer

Disclaimer: We have endeavored to ensure the accuracy and reliability of the information provided in this document. However, as the product continues to improve, the information in this document is subject to change without notice. Appotronics Corporation Ltd. is not responsible for omissions or inaccurate information. The updated version of this document is issued on a regular basis as needed. Please contact Appotronics Corporation Ltd. (hereinafter referred to as “Appotronics”) for updated version.

Installation Requirements

■ Environment Condition

The following table briefly lists the physical environment in which this projector can be operated or stored safely.

Environment	Operation	Storage
Ambient temperature	0°C -40°C (*1)	-10°C -60°C
Humidity	10%-90% RH (No condensation)	10%-90% RH (No condensation)

(*1): derating operation under 35°C -40°C.

■ Requirements for Main Power Supply

Appotronics’ large venue projectors are powered by a nominal single-phase power supply (with a special grounding PE) during operation.

Requirements for power supply: AC100-240V, 16-9A, 50/60Hz

■ Projector Weight

Please note: Do not underestimate the weight of the projector which weighs about 35kg±1kg. Be sure that the base or hanger used to install the projector can bear five times the overall system load.

Overview

Disclaimer

This product is a laser projector that utilizes Appotronics' next-generation laser light source technology. The long-lasting laser light source ensures bright displays throughout its entire lifespan. It uses DLP technology, effectively protecting users' eyes. With advanced laser phosphor display technology, it achieves significant breakthroughs in color performance, with a color gamut that exceeds the REC.709 standard.

Packaging Overview

When you open the package, please check the items in the packing box according to the following list. If any items are missing, please contact the dealer immediately.

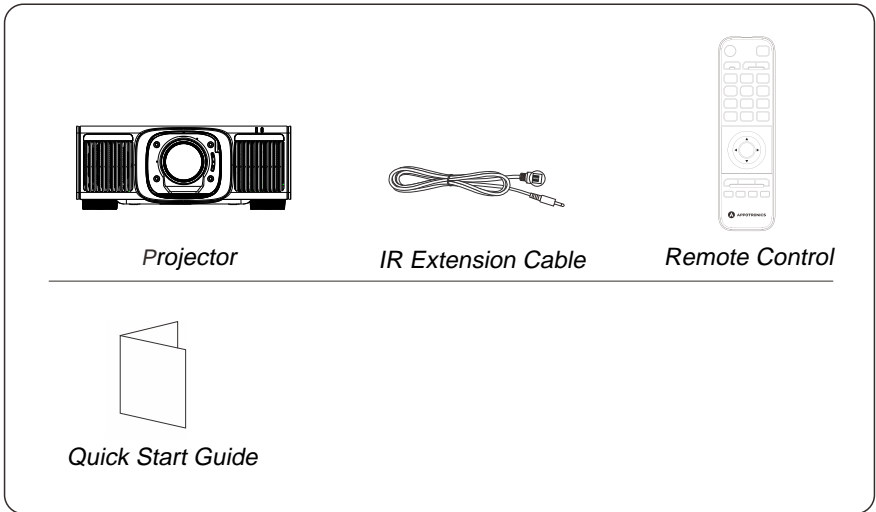

Caution

- The list of items comes with the projector varies depending on the country (region) of sale and the model, please refer to the actual item.

Overview

Projector Appearance

■ Host

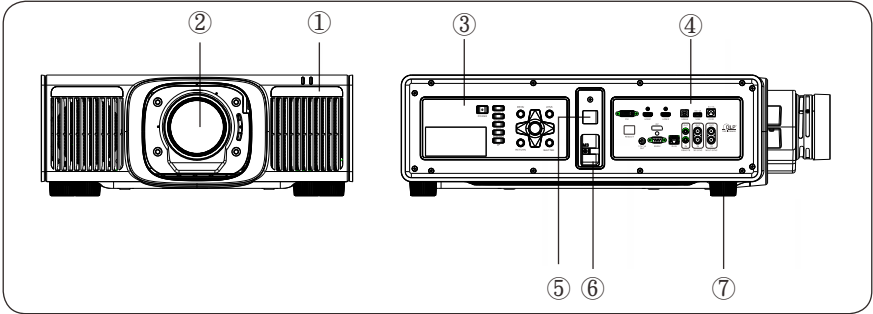

- ① Infrared Receiver (Front)
- ② Projection Lens
- ③ Control Panel
- ④ Input/Output Panel
- ⑤ Power Switch
- ⑥ Power Socket
- ⑦ Adjustment Feet

■ Input/Output (I/O) Panel

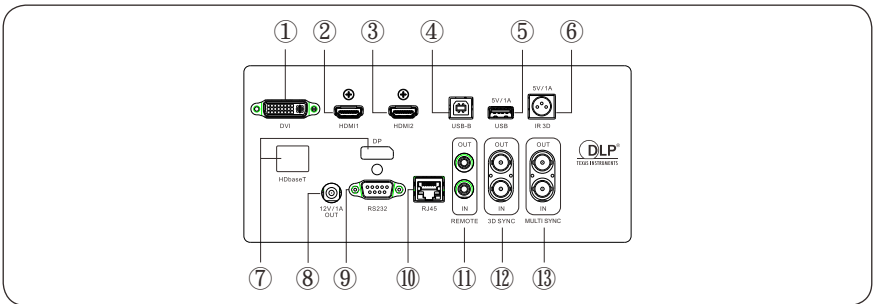

- ① DVI port
- ② HDMI1 port
- ③ HDMI2 port
- ④ USB-B port
- ⑤ USB-A port
- ⑥ IR 3D port
- ⑦ DP port/HDBaseT port
- ⑧ OUT port
- ⑨ RS232 port
- ⑩ RJ45 port
- ⑪ REMOTE port
- ⑫ 3D SYNC port
- ⑬ MULTI SYNC port

⚠ Caution

- DP and HDBaseT are optional interfaces, and the specific configuration may vary depending on the projector model. Please refer to the actual product configuration.

Overview

Interface Description

- ① DVI port: Used for connecting DVI input signals.
- ② HDMI1 port: Used for connecting HDMI input signals.
- ③ HDMI2 port: Used for connecting HDMI input signals.
- ④ USB-B port: Used for upgrades; not for user access.
- ⑤ USB-A port: Used as a power output port, supporting DC 5V/1A power supply.
- ⑥ IR 3D port: Outputs 3D sync signals and can connect to infrared emitters, etc.
The schematic diagram and definition for the IR 3D port are as follows:

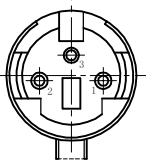

PIN	Definition	Note
1	VCC	Support 5V/1A
2	GND	Grounding
3	3D SYNC	3.3V level

- ⑦ DP port/HDBaseT port: Used for connecting DP input signals/HDBaseT input signals.
- ⑧ OUT port: Used for outputting 12V power supply, supporting 12V/1A.
- ⑨ RS232 port: This is the RS232 control terminal, which allows the projector to be controlled via a connected computer.

The schematic diagram and definition for the RS232 port are as follows:

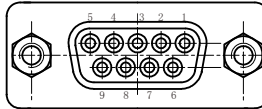

PIN	1	2	3	4	5	6	7	8	9
Definition	N.C	TX	RX	N.C	GND	N.C	N.C	N.C	N.C
Note		Projector transmitting	Projector receiving		Grounding				

- ⑩ RJ45 Port: Used for connecting to the network
- ⑪ REMOTE Port: Used for remotely controlling port, REMOTE IN can connect to an external infrared receiver.

The diagram and definitions for the REMOTE IN port are as follows:

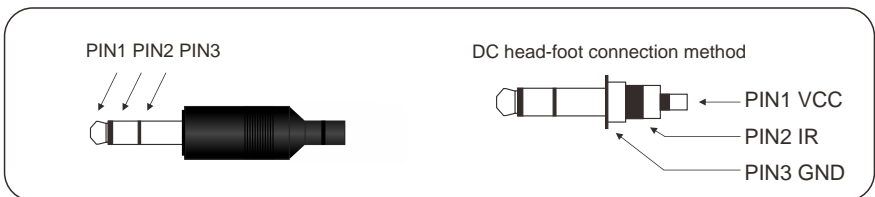

Overview

■ Interface Description

⑫ 3D SYNC Port: 3D sync signal, used for 3D synchronization between multiple machines. When in use, the devices need to be connected in a daisy chain configuration. The connection diagram is shown below:

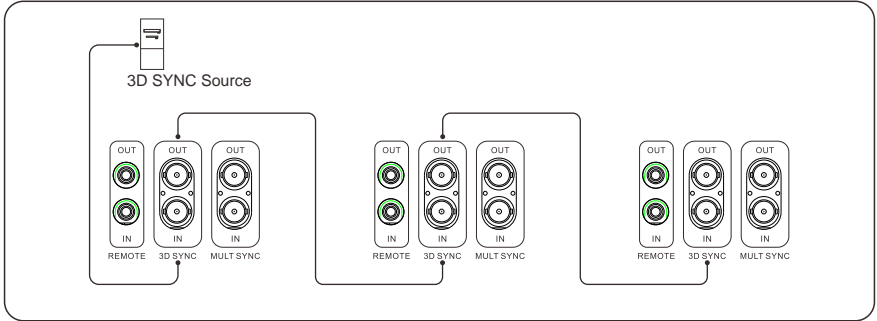

⑬ MULTI SYNC port: Dynamic contrast sync signal, used for dynamic contrast synchronization between multiple machines. The usage method is as follows:

- ◆ Set the dynamic contrast level of the machine: Menu - Image - Picture Adjustment - Dynamic Contrast (not off);
- ◆ Configure one machine as the master device: Menu - Image - Picture Adjustment - Dynamic Contrast – Contrast Sync [Master Device];
- ◆ Configure the other machines as slave devices: Menu - Image - Picture Adjustment - Dynamic Contrast -Contrast Sync [Slave Device];
- ◆ Connect the MULTI SYNC OUT of the master device to the MULTI SYNC IN of a slave device, and connect the other machines in a daisy chain configuration. The connection diagram is shown below:

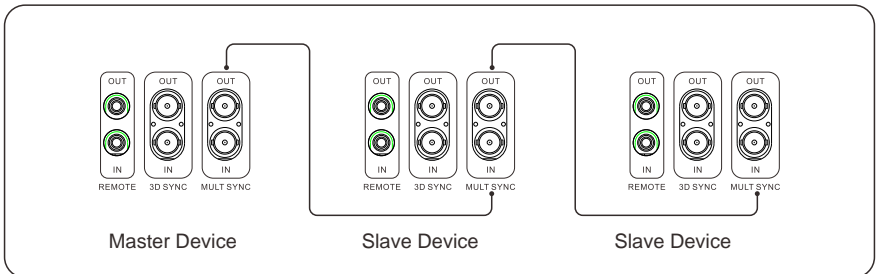

Overview

■ Control Panel

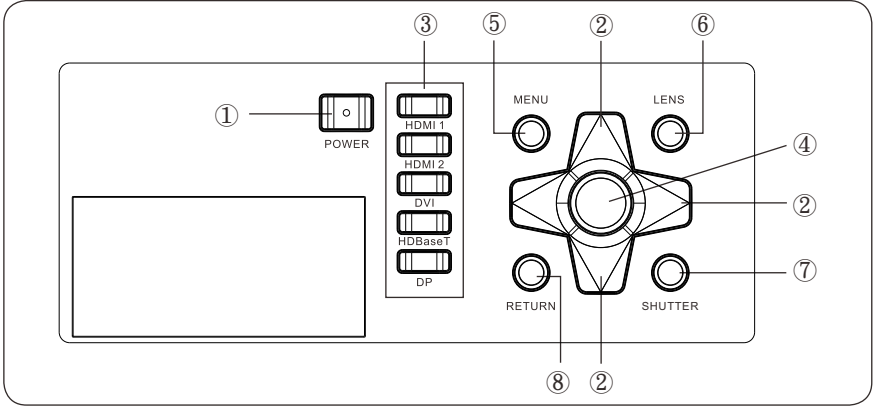

Overview

■ Control Panel

- ① Power (On/Off)
Press power button once to turn on the projector; while in the on state, press power button twice in succession to turn off the projector.
- ② Arrow Keys
Used with the menu for up, down, left, and right selection. Select the adjustment item to the left or decrease the adjustment value, and select the adjustment item to the right or increase the adjustment value.
- ③ Signal Source
From top to bottom: DVI, HDMI, HDBaseT, DP; HDBaseT and DP are optional interfaces. The specific configuration may vary depending on the projector model, so please refer to the actual configuration.
- ④ OK Button
Select / confirm the current value or selected item.
- ⑤ Menu Button
Press the menu button to display the screen menu. Press the menu button again to return to the previous menu or exit the screen menu display.
- ⑥ Lens Adjustment Key
Press to bring up / switch to the lens adjustment menu: Focus (default), Shift, Zoom.
- ⑦ Shutter Key
When there is an image displayed, press once to close the display, and press again to open the display.
- ⑧ Return Key
In menu display mode, press once to return to the previous menu. In the first-level menu, press once to exit the menu.
- ⑨ Nameplate
Location of the machine's nameplate.

The CMIIT ID is reflected on the nameplate.

Overview

Remote Control

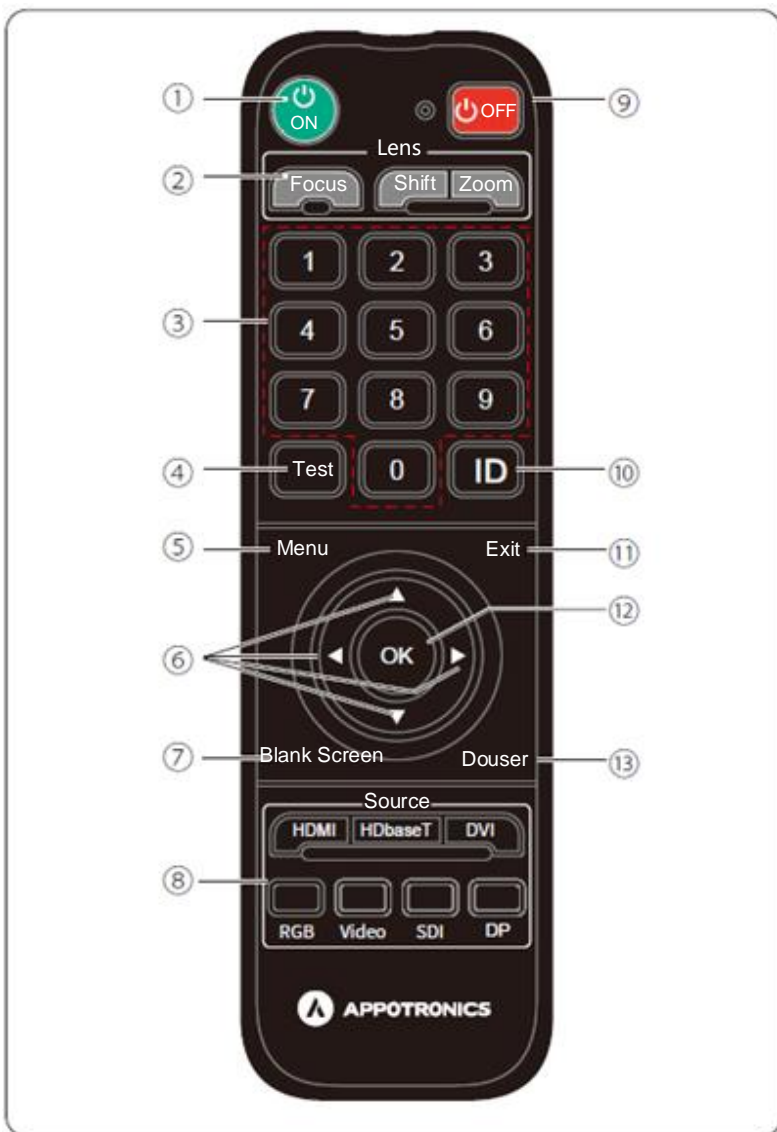

Overview

Remote Control

- ① Power on
Press once to power on when the projector is in standby mode;
- ② Lens
Press the corresponding key to enter the Lens Focus, Shift and Zoom Menu.
 - Focus: adjusts the lens focus settings.
 - Shift: adjusts the lens movement settings.
 - Zoom: adjusts the size settings of the lens projection image.

* Focus and zoom buttons are not available for manual lenses.
- ③ 1/2/3/4/5/6/7/8/9/0 (number keys)
 - Input password.
 - Enter the number of network settings in the configuration menu with this button.
- ④ Test
Displays test pattern.
- ⑤ Menu
Displays and closes the configuration menu.
- ⑥ (Arrow keys)
When the configuration menu is displayed, press these buttons to select menu items and settings.
- ⑦ Blank screen
Switches the image to blank screen mode.
- ⑧ Input source short-cut keys: switch to the signal image of each input port.
 - Switching between multiple input ports of the same signal can be done by clicking the button multiple times to switch channels.
 - The corresponding button does not work for ports that are not available in the whole machine.
- ⑨ Power off
Press the OFF button to show the shutdown prompt in the power-on state, and press the OFF button again to shut down the computer normally.
- ⑩ ID
Press this button and the number button concurrently to select the projector ID you want to operate.
- ⑪ Exit
 - Press this button to end a function currently being used.
 - Press this button to go to the previous menu while the configuration menu is displayed.
- ⑫ OK
Press this button to accept and enter the current selection and go to the next level while the configuration menu is displayed.
- ⑬ Douser
Turns the display screen on or off.

 **Caution**

- The operating angle of the remote control is within $\pm 30^\circ$.
- Press the SDI button once to get the SDI1 signal, and press it again to switch to the SDI2 signal. This device does not have a video interface, pressing the Video button will not work for this model.

Overview

Battery Replacement of the Remote Control

■ Steps

- ◆ Open the battery cover, turn the remote control with the back facing up.

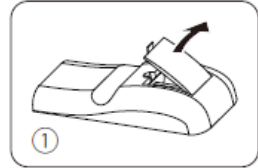

- ◆ Install the new battery into the case. Pay attention to the correct polarity (+ and -) of the two AAA batteries and ensure that the battery electrodes touch the connectors in the case.

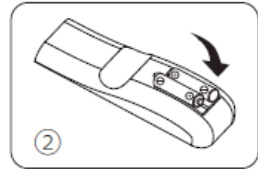

- ◆ Put on the battery cover.

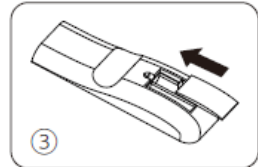

■ Precautions for remote control

- ◆ Make sure that the polarity is correct when inserting the battery.
- ◆ Do not throw the battery into the fire, as there may be a risk of explosion.
- ◆ If you plan not to use the remote control for a long time, be sure to remove the battery to prevent leakage, otherwise the remote control will be damaged.
- ◆ The liquid in the battery is harmful to the skin; Do not directly expose your hands to the leaking liquid. When installing new battery, be sure to completely remove the leaking liquid.
- ◆ In most cases, you only need to point the remote control to the screen, and the infrared signal will be reflected back from the screen and received by the infrared sensor on the projector. However, under certain circumstances, the projector may not be able to receive the signal from the remote control due to environmental factors. In this case, aim the remote control at the projector and try again.
- ◆ If the effective reception range of the signal from the remote control is shortened, or the remote control does not work, replace the battery.
- ◆ If the infrared receiver is exposed to fluorescent lights or strong sunlight, the remote control may not work properly.
- ◆ Please refer to the local government's mandatory regulations on the disposal of waste batteries; Improper disposal will be harmful to the environment.

Installation

Lens Replacement

- ◆ Before replacing the lens, ensure that the projector is turned off.
- ◆ Adjust the lens position to the center before replacing the lens. If the lens is not centered, the replacement may fail.
- ◆ Both the projector and the lens are precision instruments. Do not shake them or use excessive force. Do not touch the lens surface with your fingers during replacement.
- ◆ Be very careful to avoid leaving dust or oil on the lens surface, and do not scratch the lens. Do not replace the lens in a dusty room. Dust entering the projector may cause image quality to degrade.
- ◆ Do not leave the lens and projector separated for long periods. Dust entering the projector may cause image quality to degrade. Do not touch the signal contacts of the lens with your fingers. If dust gets on them, it may cause contact failure.
- ◆ Do not transport the projector with an optional lens installed, as it may cause damage to the projector.
- ◆ Attention: Do not insert your hands into the installation slot as there is a risk of burns, scratches, or electric shock.

Lens Removal

- ◆ Support the bottom of the lens with one hand, and with the other hand, lift the lens locking switch upwards.
- ◆ Use both hands to slide the lens forward to remove it.

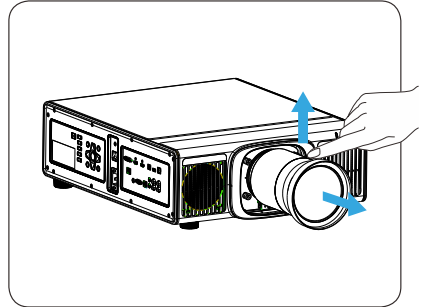

Lens Installation

- ◆ Remove the protective cover from the lens.
- ◆ Align the connector on the bottom of the lens with the focusing and zoom motor of the projector.
- ◆ Push the lens forward to connect it.

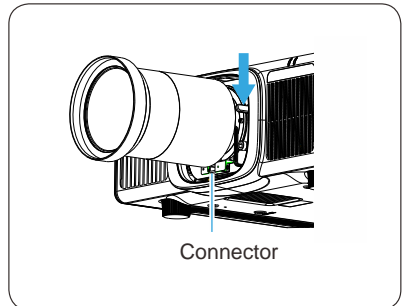

Installation

Projector Connection

■ Connecting to a computer or laptop

- ① Power cable
- ② DVI cable
- ③ HDMI1 cable
- ④ HDMI2 cable
- ⑤ DP cable
- ⑥ RS232 cable
- ⑦ RJ45 cable
- ⑧ HDBaseT cable

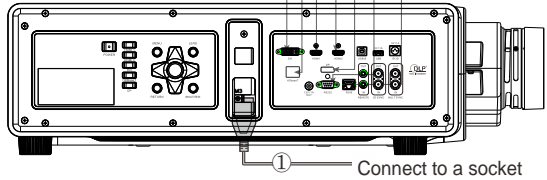
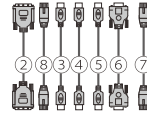

■ Connecting to a video device

- ① Power cable
- ② DVI cable
- ③ HDMI1 cable
- ④ HDMI2 cable
- ⑤ DP cable
- ⑥ HDBaseT cables

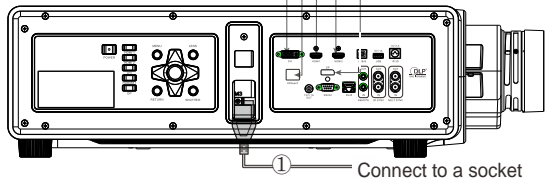

Installation

Turning on/off the Projector

■ Turning on the Projector

- ◆ Ensure that the power cable and signal cable are firmly connected. Turn on the power switch and wait until the status LED turns red stably.
- ◆ Press the power button on the remote control or control panel to turn on the projector, the status LED will turn green and enter the display screen of "no signal".
- ◆ Turn on the signal source: Press the SOURCE button on the remote control or the control panel to select the signal (HDMI1, HDMI2, HDBaseT, DVI or DP) and the projector will detect the input source you selected and display the image.

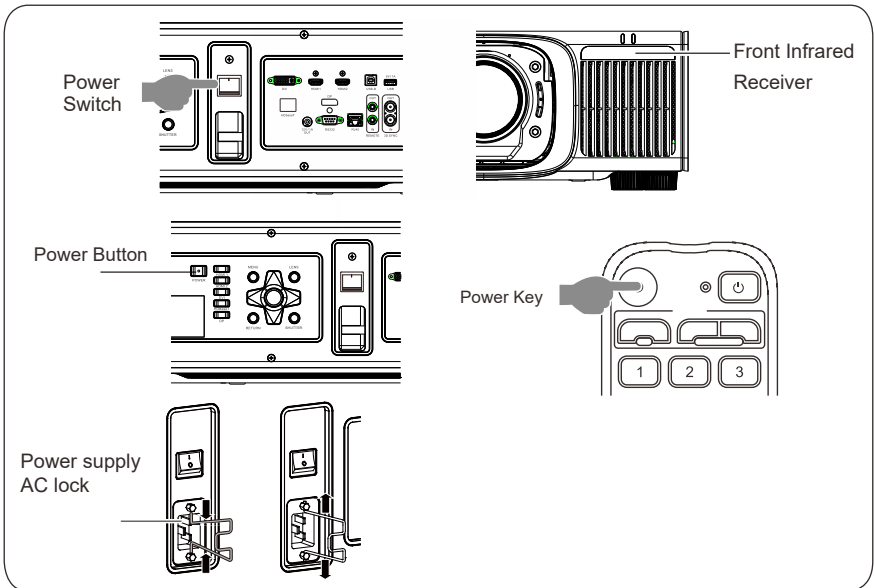

■ Turning off the Projector

- ◆ Press the power button on the remote control or control panel, and the projector will shut down.

■ Installation diagram for power supply AC lock

- ◆ To prevent the power cord from loosening, it is necessary to install the AC lock as shown in the diagram. Press on both ends of the lock, align it with the hexagonal through-hole pin as shown, and release it to allow both ends of the lock to engage.

Caution

- Do not turn on the projector immediately after it enters standby mode.

Installation

Adjusting the Projected Image

■ Adjusting the Position of the Projector

To determine where to place the projector, consider the size and shape of the screen, the location of the socket, and the distance between the projector and other devices.

Here are some general principles:

- ◆ Place the projector on a flat surface and maintain the correct angle with the screen.
- ◆ Position the projector at the ideal distance from the screen.
- ◆ The distance from the projector lens to the screen, zoom settings, and video format determine the size of the projected image.

For the image offset (shift) range of this projector, see the table below:

Model	H	V
AL-SK20KP	±40%	±100%

H: Horizontal offset range of the image when the lens is centered.
V: Vertical offset range of the image when the lens is centered.

⚠ Caution

- The above table shows the offset values for the AL-SK20KP; the displacement of non-standard optional lenses is based on the actual lens specific ations.

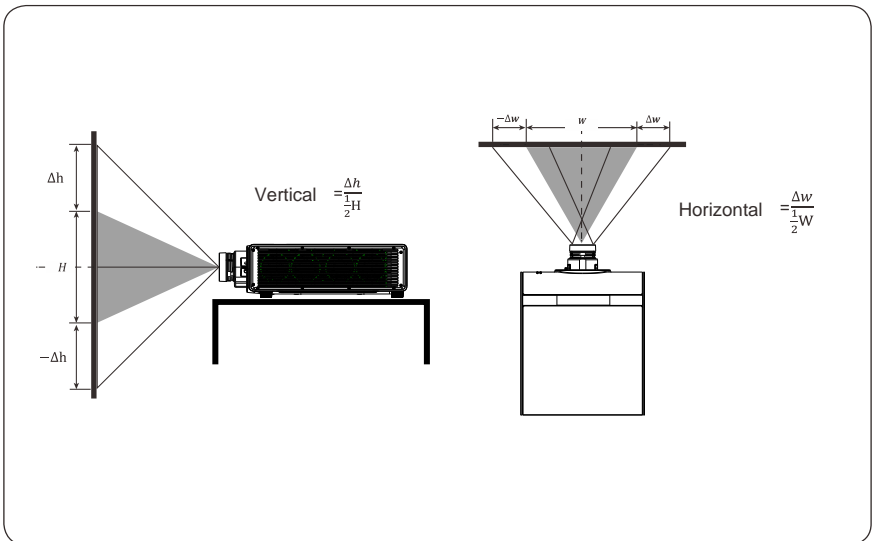

Installation

Schematic Diagram of Vertical Offset with Lens Centered.

For the vertical offset range when the lens is centered, please refer to the table above.

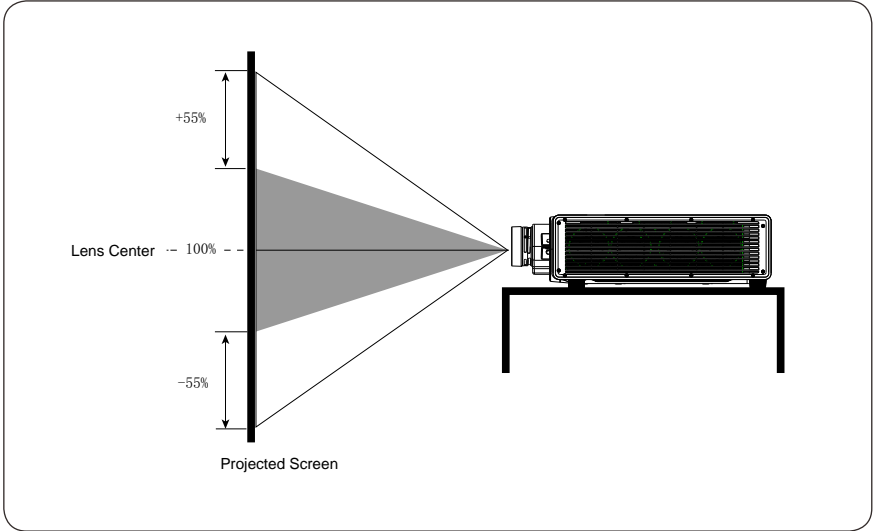

Schematic Diagram of Horizontal Offset with Lens Centered

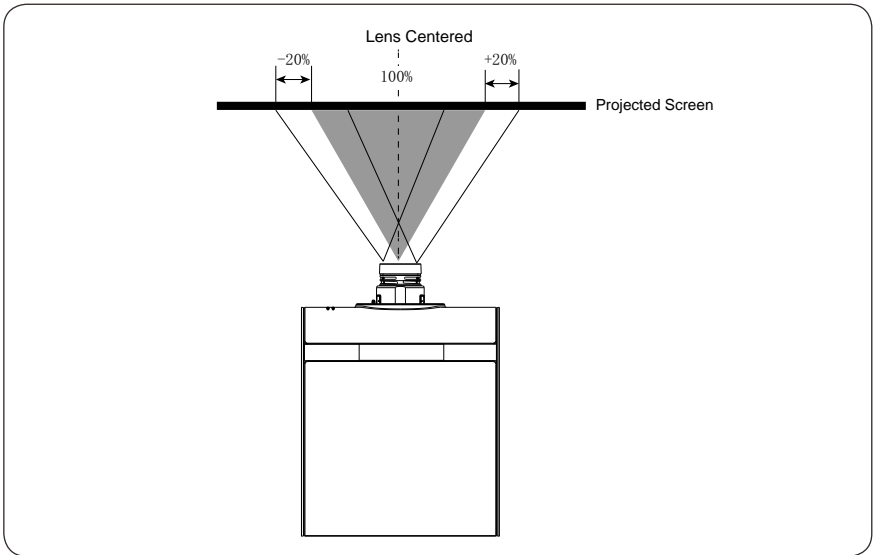

Installation

Ceiling Installation

- ◆ The position where the projector is installed or the support frame shall be able to withstand sufficient weight. If the intensity is insufficient, the position of the projected picture may shift.
- ◆ Adjustable foot is only for mounting on the floor and adjusting the angle. Using it for other purposes may damage the projector.
- ◆ Remove adjustable feet if not required in the installation. However, do not use the screw mounting holes with adjustable foot removed for other purposes, such as attaching the projector to the support frame.
- ◆ In addition, in the screw holes after removing the adjustable foot, do not install any screws not specified in the accessory manual. Otherwise, it may damage the projector.

Remove the four adjustable feet and secure the projector with six screw mounting holes (as shown in the figure, except for the floor or the ceiling bracket). In this case, insert the gasket (metal work) into the lifting screw mounting hole at the bottom of the projector and the mounting surface to ensure that there is no gap between them.

- ◆ Tighten the fixing screw to the specified tightening torque using a torque screwdriver or a hexagonal torque wrench. Do not use an electric screwdriver or an impact screwdriver. For screws used to fixing the projector, use IS0898-1 standard screws (Strength grade not less than 8.8). (Screw diameter: the M8 screws are recommended; tapping depth inside the projector: 20 mm (25/32 "); screw tightening torque: Not exceeding 5.0 N · m)

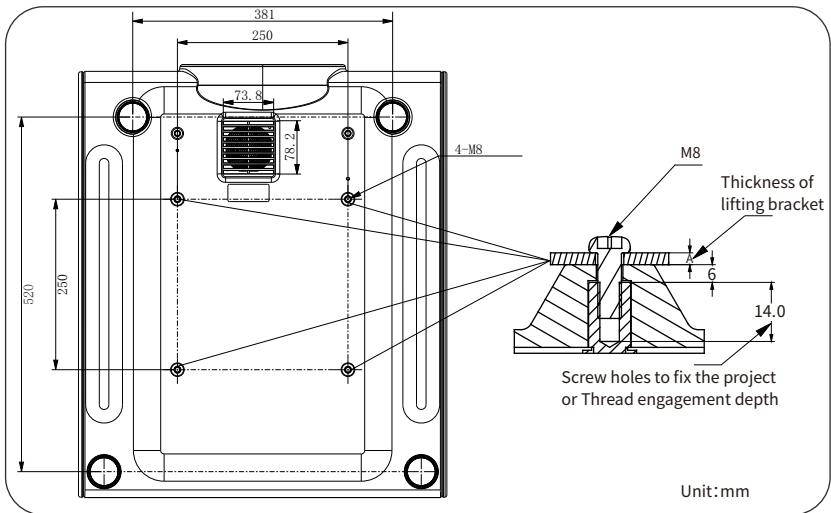

Caution

- Damage caused by improper installation will invalidate the warranty.

Installation

Cooling Duct and Airflow Description

- ◆ It is recommended that the constant temperature box design refer to the indicated airflow direction openings; there should be no obstructions at least 15 cm (6 inches) in front of the intake and exhaust ports.
- ◆ Airflow and duct description: See the schematic diagram below.

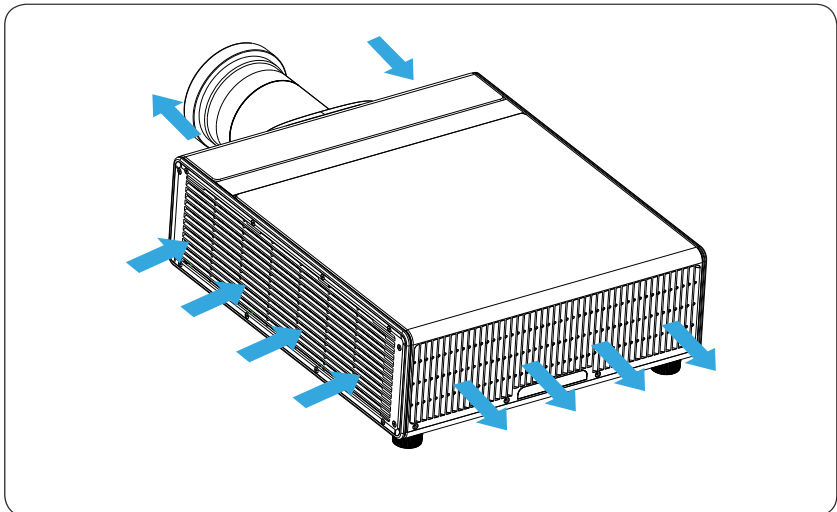
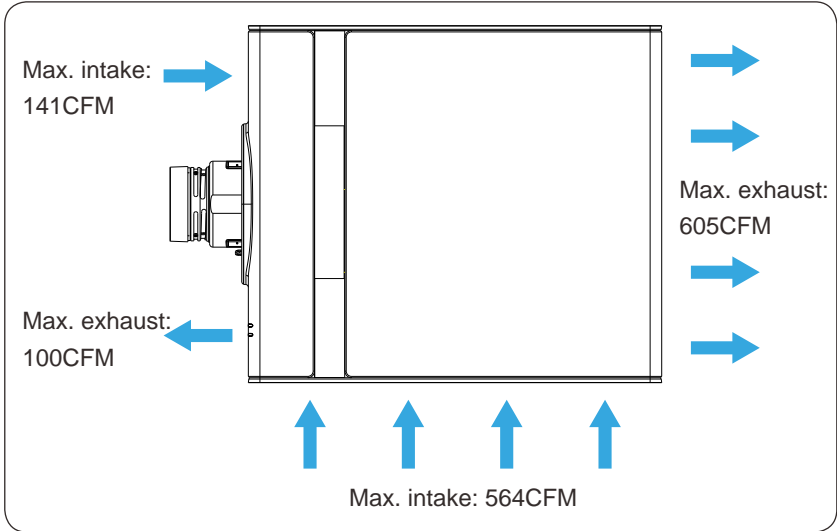

Projected Image

Enter the first-level system menu selection screen with the menu button on the remote control or the buttons. The schematic diagram below shows the first-level system menu interface, divided into five main functional modules: Image, Installation, Settings, Signal, Information.

Projector Menu

First-Level Menu	Sub-Menu Selection
Image	Image and color adjustment, aspect ratio, geometric correction, edge blending, etc.
Installation	Installation method, test pattern, lens adjustment, ID settings, remote reception, mechanical shutter.
Settings	Power, network, serial port, menu settings, operating mode, system reset settings, etc.
Signal	Signal, HDMI, 3D settings, signal reset settings, etc.
Information	Usage time, version, model ID, resolution, wireless network, and operating mode information, etc.

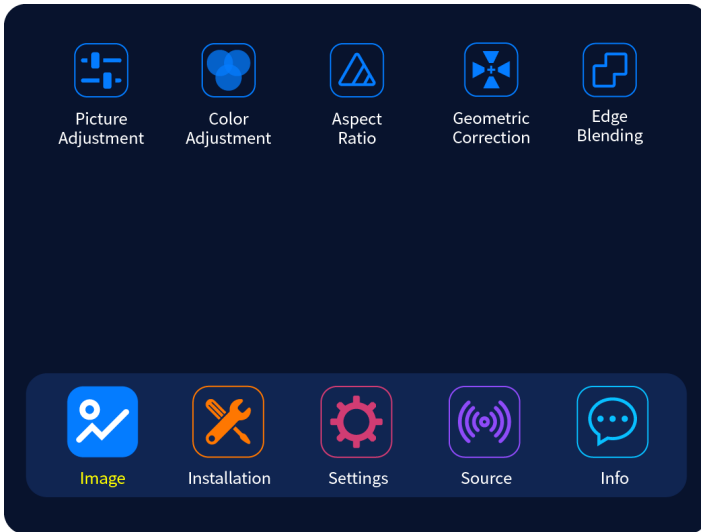

Caution

- The image mode is related to gamma selection, color settings, and extreme color functions.

Projected Image

Picture Adjustment

From the main menu, select the Image menu, enter the picture modes in Picture Adjustment, and simply select the setting that best suits the environment to easily obtain the best image quality. The image brightness varies according to the selected mode.

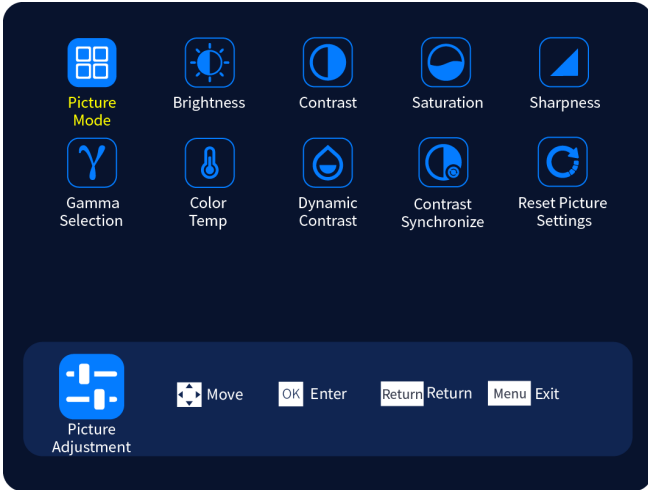

Select the picture mode and use the ◀▶ keys to switch scene modes.



Mode	Application
Standard	Vivid image, very lively. It is suitable for presentations in bright rooms or watching TV.
Image	It ensures good viewing even in high-brightness environments (e.g., with lights on, in open spaces, etc.).
Cinema	Natural tone images. It is suitable for watching movies in dark rooms.
DCI-P3	Wide color gamut range, vibrant visual experience.
BT.2020	Wider color gamut space, providing a realistic and detailed visual experience.
DICOM (Simulated)	It can display images with clear shadows. It is suitable for projecting X-ray photos and other medical images. Note: The projector is not a medical device and cannot be used for medical diagnosis.
Low Latency Mode	It reduces the delay time between input and output images.
Custom	Initial values are set as standard mode parameters, adjustable as needed.

Projected Image

Picture Adjustment

■ Brightness Adjustment

Select the [Brightness] menu and use the ◀▶ keys to switch to adjust the brightness of the projector, modifying the overall light and dark levels of the digital image.

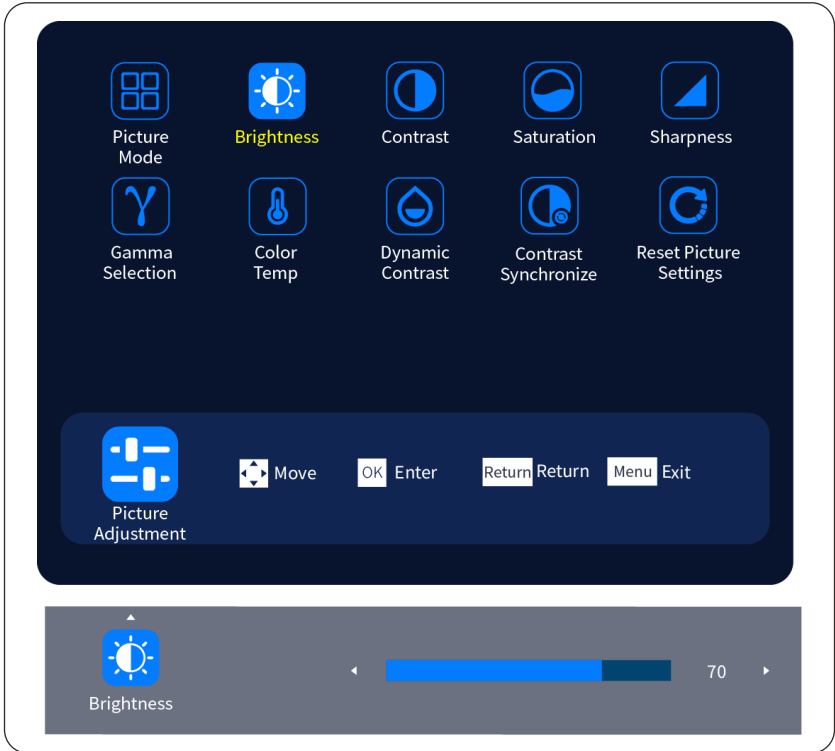

■ Contrast/Dynamic Contrast Adjustment

- ◆ In the Picture Adjustment menu, select the corresponding mode and use the ◀▶ keys to switch to complete the configuration.
- ◆ Contrast: Adjust the contrast of the image.
- ◆ Dynamic Contrast: Dynamically adjust the projection brightness based on image brightness.

Projected Image

- ◆ Contrast Synchronization: Using the contrast synchronization feature for multi-projector stitching and blending, the brightness levels of the shared input image signals can achieve a balanced combination effect (only one main device is allowed in a multi-device setup).
- ◆ When dynamic contrast is not in the off state, press the OK key to switch to Contrast Synchronization adjustment (the font changes from gray to bright), and use the left/right keys to select the main/slave devices.



Projected Image

Picture Adjustment

■ Saturation Adjustment

- ◆ Select the [Saturation] menu, and use the ◀▶ keys to adjust the saturation of the projector. The higher the saturation, the more vibrant the colors; the lower the saturation, the duller the colors, tending towards gray. When the saturation is set to the minimum, the color becomes gray.

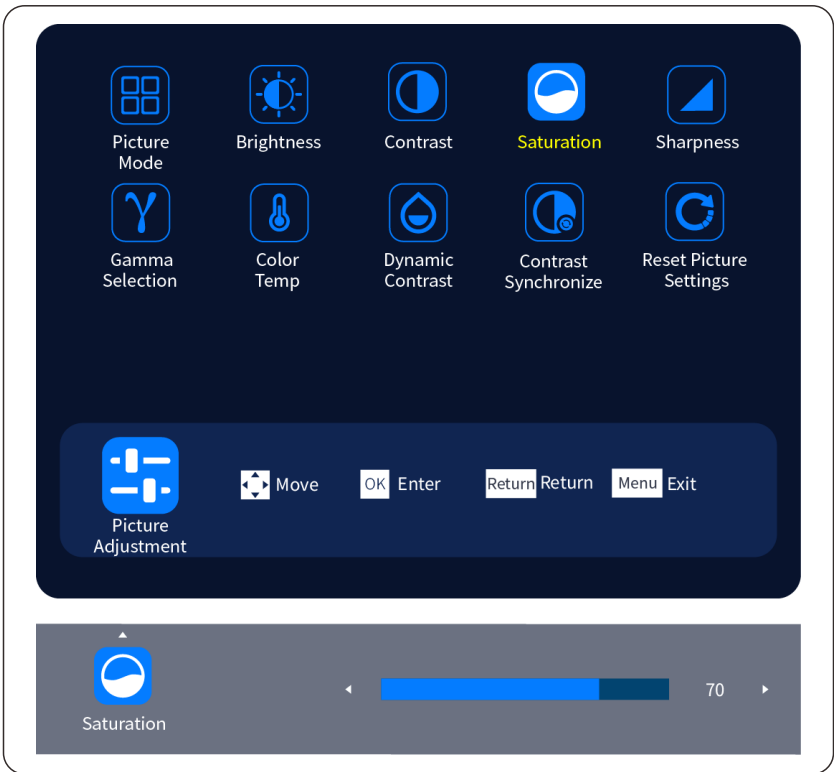

Projected Image

Picture Adjustment

■ Sharpness Adjustment

- ◆ Select the [Sharpness] menu, and use the ◀▶ keys to adjust the sharpness of the projector. Sharpness enhances the contrast of the edges in the image to highlight details, making the image appear clearer and more vivid.

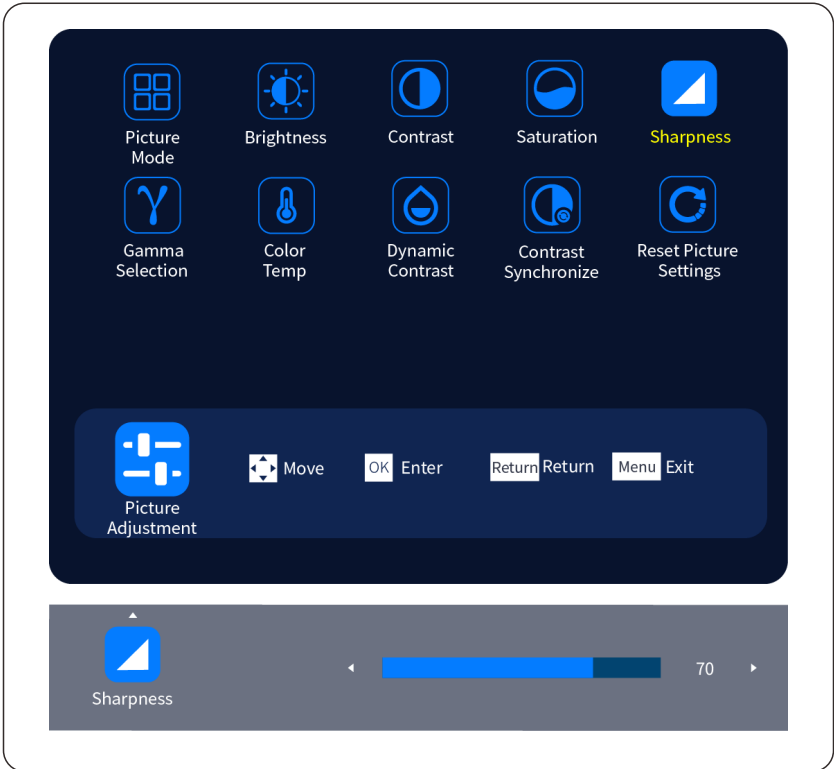

Projected Image

Picture Adjustment

■ Gamma Mode Adjustment

Users can adjust the required gamma mode according to the connected device to achieve the desired display effect.

- ◆ During projection, enter the [Picture Adjustment] menu;
- ◆ Select [Gamma] and then use the ◀▶ keys to switch.

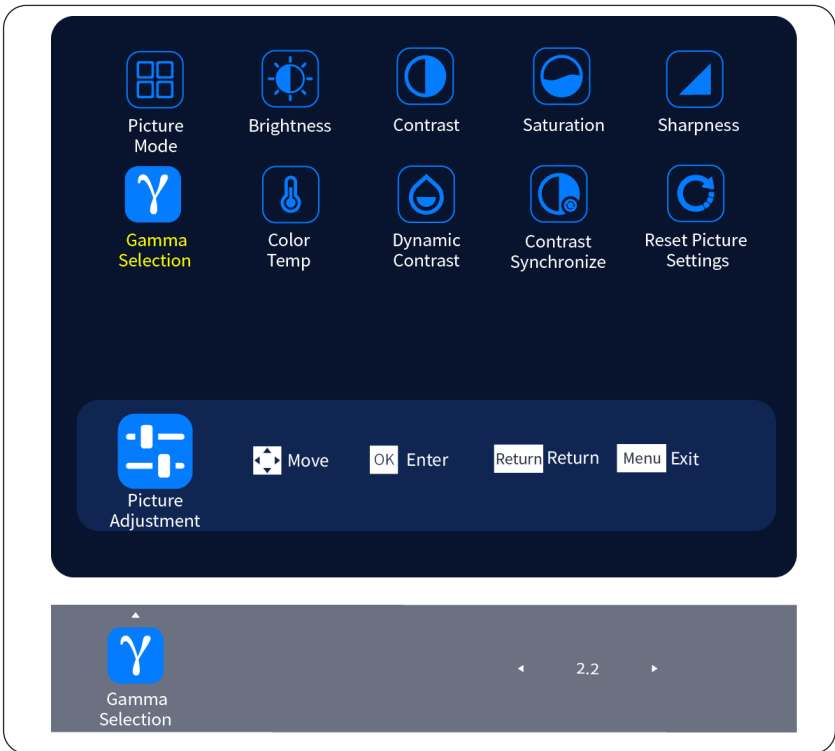

⚠ Caution

- Adjust using static photos for gamma adjustment. Using videos will not correctly adjust gamma.

Projected Image

Picture Adjustment

■ Color Temp. Mode Adjustment

- ◆ Enter [Picture Adjustment] → [Color Temp. Adjustment]; there are four mode options: Standard, Warm, Cool, Custom. Use the◀▶keys to switch and complete the corresponding configuration to achieve the desired color temperature effect.



Projected Image

Picture Adjustment

■ Picture Reset Adjustment

- ◆ Picture reset will restore all options on the Picture Adjustment page to factory default values, corresponding to the image effects calibrated at the factory.

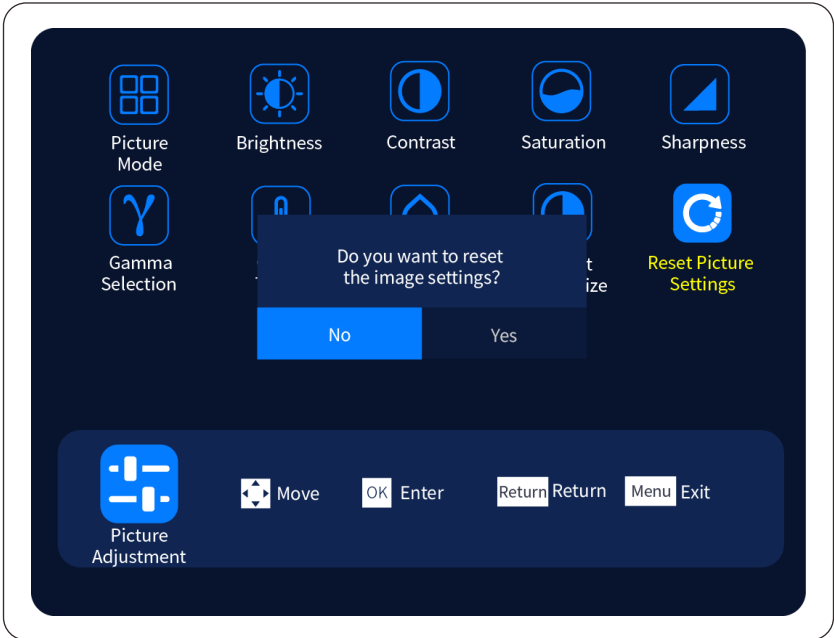

Projected Image

Color Adjustment

■ 7 Color Adjustment

The user can adjust the hue and saturation of the following seven axes according to preference: R (red), G (green), B (blue), C (cyan), M (magenta), Y (yellow) and W (white).

- ◆ Select 7 Color Adjustment from the Color Adjustment menu for settings.

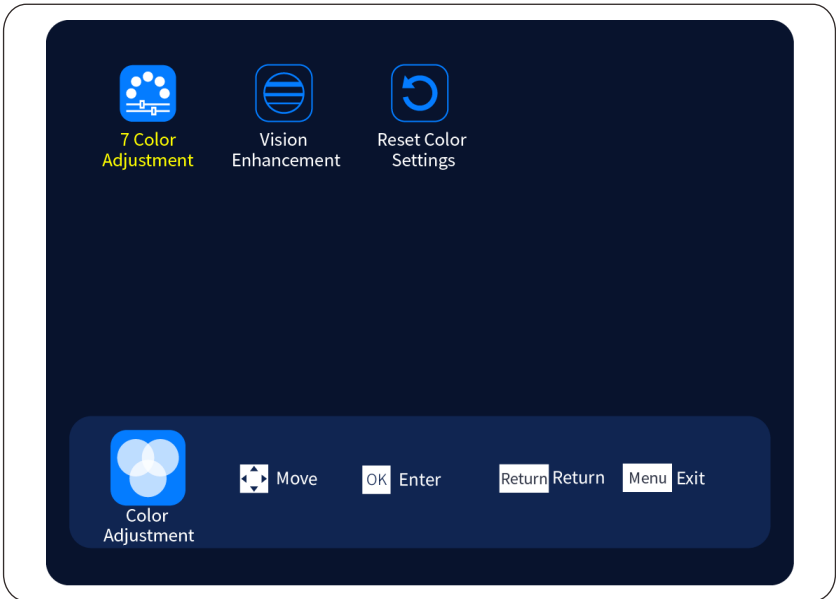

- ◆ Press the OK key to enter the corresponding numerical adjustment (use the ◀▶ keys to increase or decrease the value) or switch to selection mode (use the ▲▼◀▶ keys to select).

	Red	Green	Blue	Cyan	Magenta	Yellow	White
Sat.	100	199	199	100	0	55	Red 0
Hue	-99	55	99	0	-99	55	Green 55
Gain	◀ 55 ▶	55	199	100	0	55	Blue 199

Projected Image

Color Adjustment

■ Color Adjustment Vision Enhancement

The values defined by the user, and gains for the 6 corresponding colors (Red, Green, Blue, Cyan, Magenta, Yellow) in the 7 Color Adjustment.

- ◆ Select Vision Enhancement from the Color Adjustment menu for settings.
- ◆ Press the OK key to enter the corresponding numerical adjustment (◀▶ keys can be used for value increase or decrease) or switch to selection mode (use ▲▼◀▶ keys to select).



■ Color Adjustment Reset

Supports color reset, which will restore to the default factory best effect. The user can select Yes/No in the menu below to decide whether to perform a color reset.

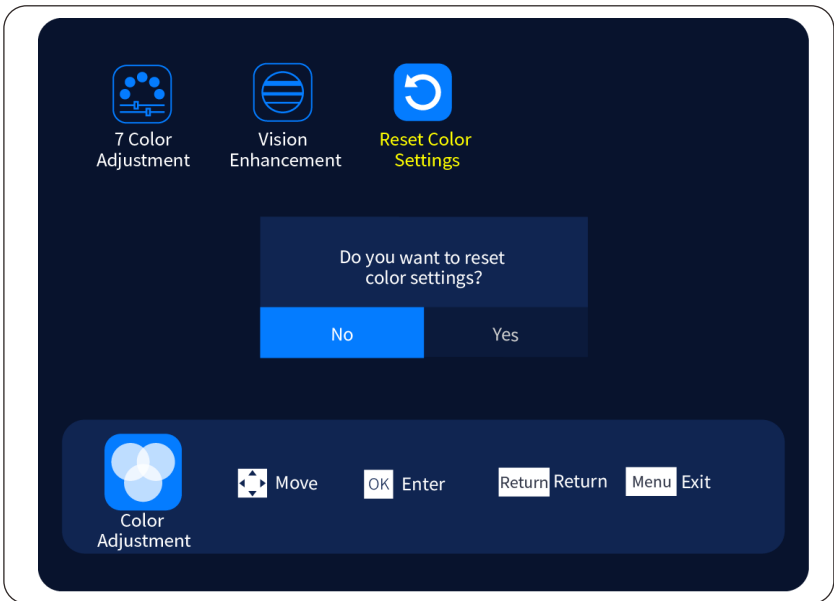

Projected Image

Aspect Ratio

The user can change the aspect ratio of the projected image based on the size of the projected image.

- ◆ Enter the main menu and select the Image menu, then choose Aspect Ratio to switch between options using the ◀▶ keys to find the appropriate aspect ratio for projection.

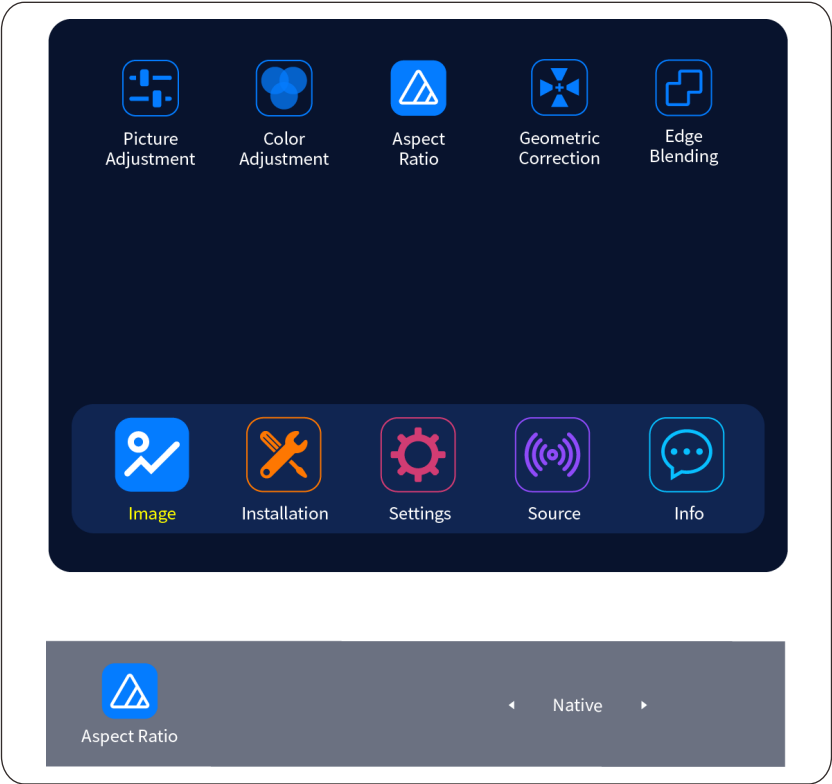

Aspect Ratio	Description
Native	Projection at the size of the input source image.
Full	Projection at the full size of the projection screen.
16:9	Projection at an aspect ratio of 16:9.
16:6	Projection at an aspect ratio of 16:6.
4:3	Projection at an aspect ratio of 4:3.

Projected Image

Geometric Correction

■ Geometric Correction

Unique image processing techniques are used to match the projection onto screens with special shapes, making the projected image appear more natural. Geometric correction includes corner correction, trapezoidal correction, curvature correction, and multi-point correction, allowing users to choose the desired correction mode.

- ◆ In the Image page, selects Geometric Correction to enter the geometric correction menu. Switches between different correction modes (Off, Corner, Trapezoidal, Curvature, Multi-Point) via Correction Type.

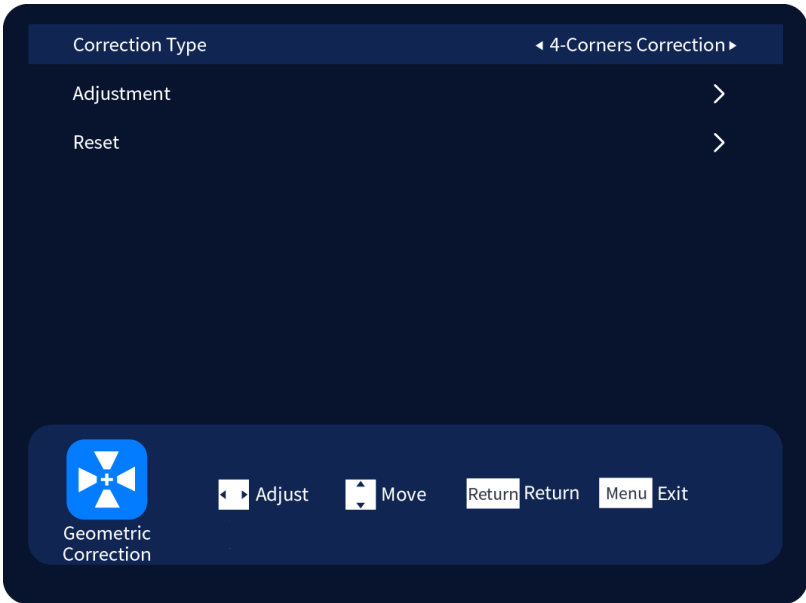

- ◆ After selecting corner correction, move the cursor to the Adjust option and press the OK key to enter specific correction. When the positioning point is yellow, use the ▲▼◀▶ keys to move the selection point. Pressing the OK key change s the positioning point to red, entering the deformation adjustment state. Follow the prompts in the menu to proceed.

Projected Image

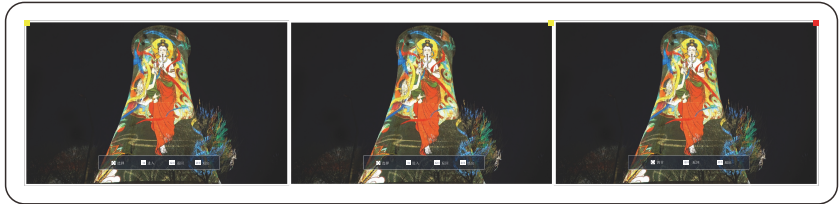

Edge Blending

The stitching and blending of multiple projectors aim to create a larger and higher-resolution image through the combination of multiple projectors. It involves two main steps to achieve multi-projector stitching and blending:

- ◆ Screen segmentation
- ◆ Edge blending

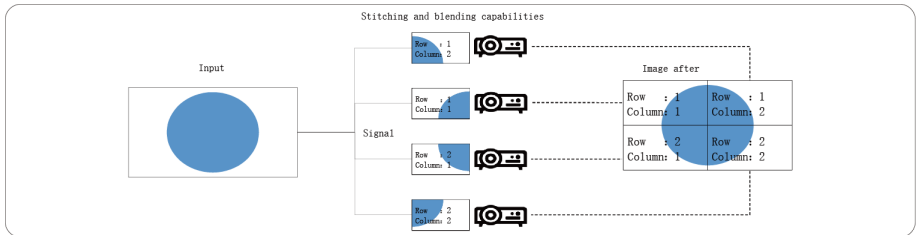

With built-in stitching and blending capabilities, it provides high-definition and large-size display solutions for various application scenarios.

- ◆ It supports edge blending across multiple machines for seamless stitching.
- ◆ It allows the same image to be segmented into multiple parts for display on a large screen using multiple projectors.



Projected Image

Edge Blending

■ Screen Segmentation

The function of screen segmentation: to confirm the stacking position of multiple projectors.

Choose the stacking method: Rows 1-9, Columns 1-9. The specific steps are as follows:

- ◆ Enable screen segmentation.
- ◆ Adjust the segmentation method. The number of projectors needed for blending is determined by the stacking method. The product of the number of rows and columns in Segmentation Method equals the number of projectors. (For example: for horizontal stitching of three projectors, corresponding to Row 1, Column 3. Each projector should have the same configuration for this option.)
- ◆ The position on the screen corresponds to the unit ID of each projector in the blended image.D.

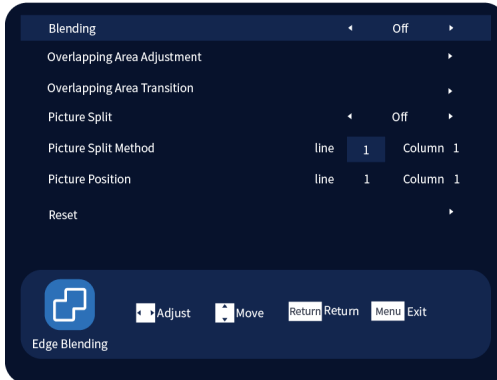
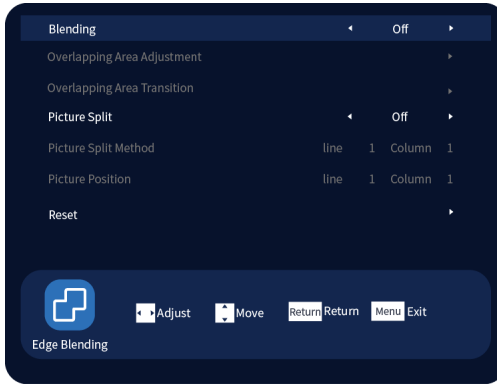

Projected Image

Edge Blending

■ Edge Blending

The function of edge blending: to process the stitched image and eliminate brightness differences in the blending area and non-blending areas, as well as the transitional edges between images, making the entire large image appear more natural. The specific steps are as follows:

- ◆ Enable blending.
- ◆ Adjustment of the blending zone: It adjusts the overlap edges and area size of the blending zone.
- ◆ Transition adjustment of the blending zone: by adjusting the red/green/blue gamma values in the blending area, the brightness of the blending area matches that of the non-blending area.



Projector Installation

The options covered on the Installation page are crucial for the correct operation and use of the projector, including the Installation Method, Lens Settings, Projector ID, Mechanical Shutter Settings, and more. Enter the system level menu through the menu button on the remote control or the control panel. Below is the interface for the system level menu.

Projection Menu

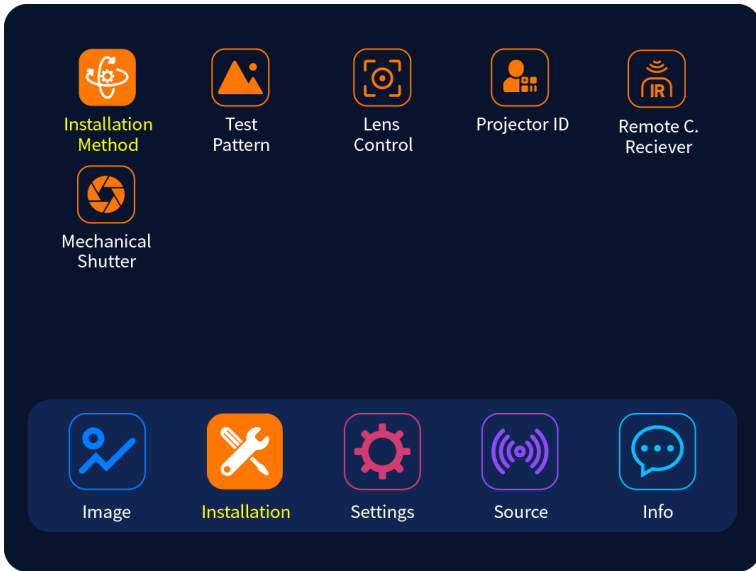

Function	Application
Installation Method	Desktop Front (default) / Desktop Rear / Ceiling Front / Ceiling Rear.
Test Pattern	Off (default) / Grid / White / Red / Green / Blue / Cyan / Magenta / Yellow / Black / 256 Grayscale / Color Bars / Checkerboard.
Lens Adjustment	Shift (default) / Focus / Zoom / Center.
Projector ID	Projector ID (default upon entering main menu) / Remote C. ID (default when entering with Remote C. ID key).
Remote Reception	Front On Rear On (default) / Front On Rear Off / Front Off Rear On.
Mechanical Shutter	On (default) / Off.

Projector Installation

Lens Adjustment

- Quick Lens Adjustment: Shift adjustment, focus adjustment, and screen zoom adjustment.
- ◆ Shift: Select the Shift button on the remote control and directly adjust the position of the projected image using the▲▼◀▶ arrow keys according to the actual situation.



- ◆ Auto Centering: Press the Shift button on the remote control for more than 3 seconds to bring up the lens auto center menu. Press the OK key to enter lens centering adjustment, ultimately centering the lens.

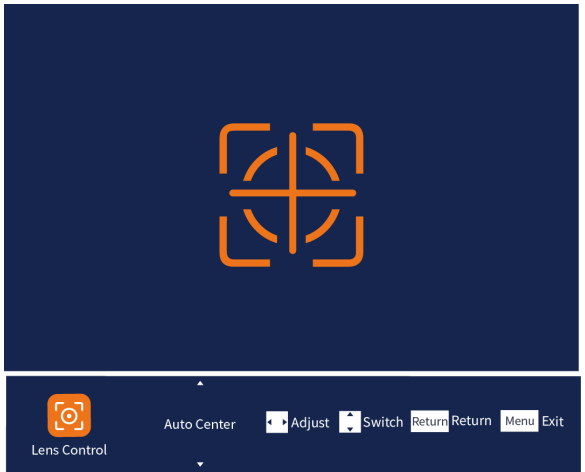

Projector Installation

Lens Adjustment

- Quick Lens Adjustment: Shift adjustment, focus adjustment, and screen zoom adjustment
- ◆ Focus: Select the Focus button on the remote control to enter the lens adjustment menu. Use the ◀ ▶ adjustment keys to adjust the focus until the projected image is clear.

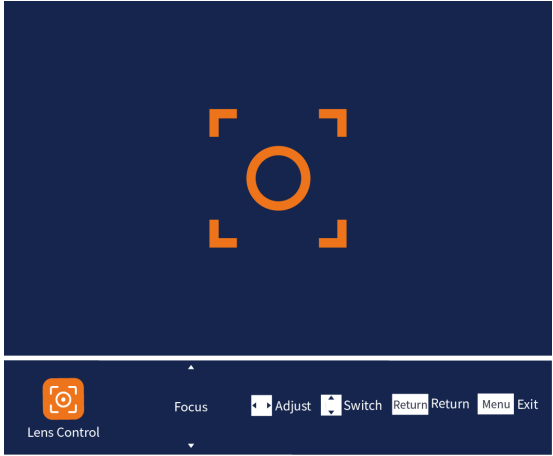

- ◆ Zoom: Select the Zoom button on the remote control to enter the lens adjustment menu. Use the ◀ ▶ arrow keys to zoom in or out within the designed range.

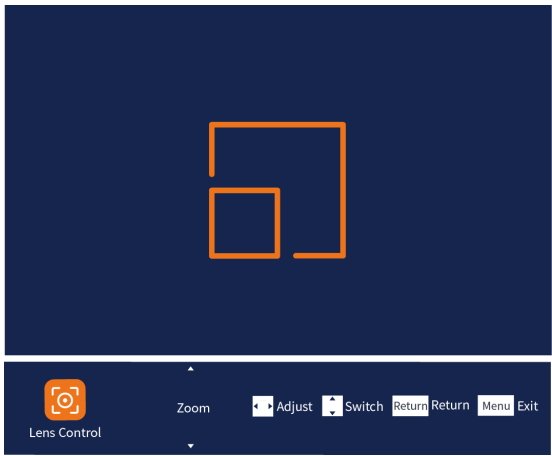

Projector Installation

Projector ID

- The projector ID is a configurable number (range 00-99) for each projector, used in conjunction with the remote control ID (range 00-99) to achieve single-unit control functionality.



- ◆ Both ID settings can be directly modified using the numeric keys. After input, press the OK key to save and exit editing mode.
- ◆ Response Description:
 - When Projector ID = 00, Remote ID = Any, it responds to the remote control.
 - When Remote ID = 00, Projector ID = Any, it responds to the remote control.
 - When both are $\neq 00$ and Projector ID = Remote ID, it responds to the remote control.
 - When both are $\neq 00$ and Projector ID \neq Remote ID, it does not respond to the remote control.

Projector Installation

Remote C. Reception

- The projector has an infrared remote control receiver on the front and the rear respectively, both set to on by default to maximize the sensing range. Users can also set corresponding switches based on specific scenarios through the Remote Reception option in the menu, as shown below:

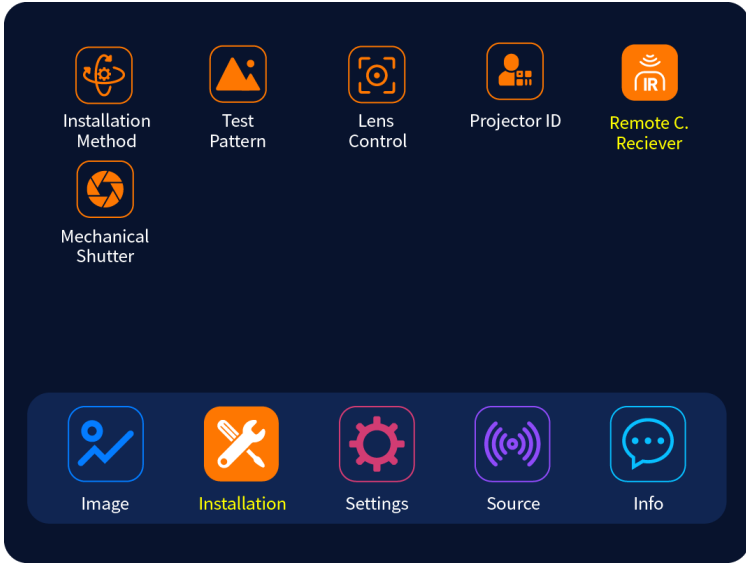

- ◆ The options for remote reception settings are: Front On Rear On (default), Front On Rear Off, Front Off Rear On.



Projector Installation

Mechanical Shutter

■ The mechanical shutter is primarily based on safety considerations to protect the projector. Closing the mechanical shutter after the projector is turned off can reduce dust and smoke particles from entering the projector, as well as prevent damage to internal optical components (like DMD) from external bright light, thereby protecting the projector and extending its lifespan. The Mechanical Shutter option menu on the Installation page is as follows:

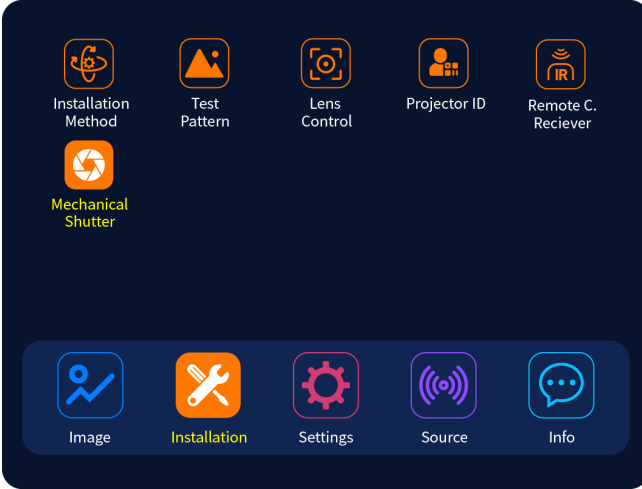

- ◆ On (default): The mechanical shutter will close after the projector is turned off, preventing external laser beams from damaging the DMD.
- ◆ Off: The mechanical shutter remains open at all times.



- ◆ In the Mechanical Shutter adjustment state, press the OK key to enter the Linkage adjustment option.
- ◆ Linkage On: The electronic shutter switch will correspondingly switch the mechanical shutter.
- ◆ Linkage Off: The electronic shutter switch will not affect the mechanical shutter.
- ◆ When the mechanical shutter is set to On and the linkage is set to On, the electronic shutter switches from Off to On state in about 3 seconds.

Caution

- It is strongly recommended not to modify the default configuration of the mechanical shutter.

Projector Installation

Settings

■ Power Settings

The Power Settings page includes standby mode settings, auto standby, power-on settings, and high-altitude mode.

 **Caution**

- ◆ Press the Menu button on the control panel or remote control.
- ◆ Select the Settings menu and enter Power Settings.

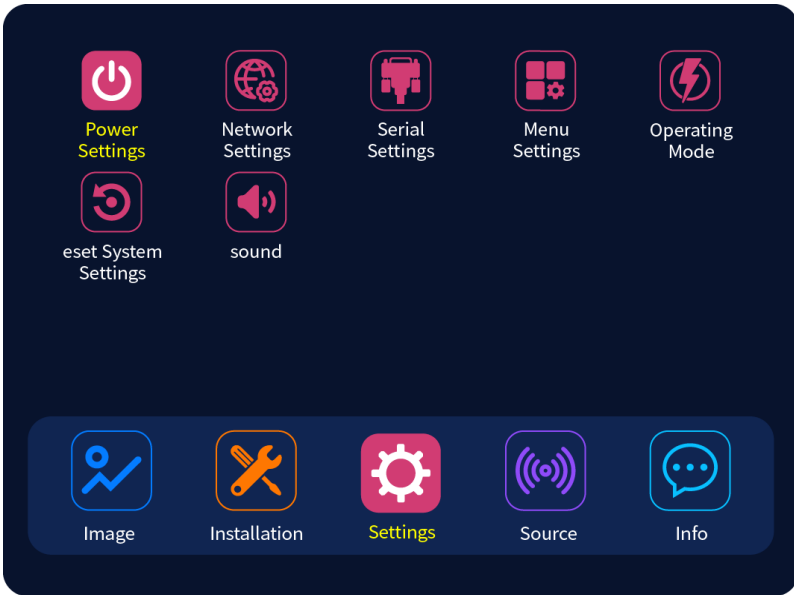

Function	Application
Standby Settings	Low Power / Network Standby (default)
Auto Standby	Off / 5 minutes / 10 minutes / 15 minutes / 30 minutes (default)
Power-On Settings	Manual (default) / Power-On / Signal Wake-Up
High-Altitude Mode	On / Off (default)

Projector Installation

Settings

■ Network Settings

Users can connect the network cable to the RJ45 port or HDBaseT port for network control of the projector. The HDBaseT port supports simultaneous transmission of audio and video signals and network control of the projector.

⚠ Caution

- ◆ Press the Menu button on the control panel or remote control.
- ◆ Select the Settings menu and enter Network Settings.

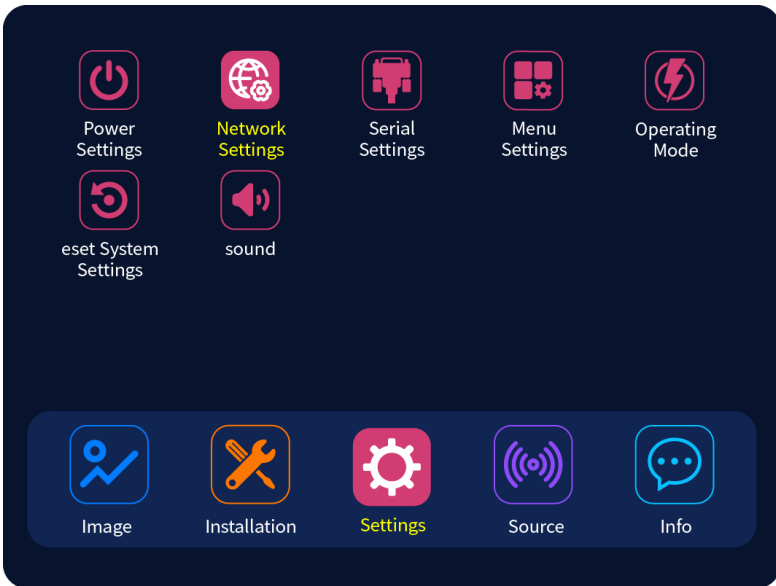

■ Network Control

- ◆ PJLink: Users can control and manage the projector through the PJLink protocol, compatible with PJLink Class 1/2 commands.
- ◆ Central Control Software: Easily manage and use the projector with the LightPeak central control software APCS. Install the APCS software on the host, ensuring the host and the projector are on the same local area network to control all projector functions and monitor daily operating status in real time.

Projector Installation

Settings

■ Network Settings

- ◆ After entering the Network Settings menu, users can configure the projector's IP address.
- ◆ Network Type: Wired Local Area Network, 4G.

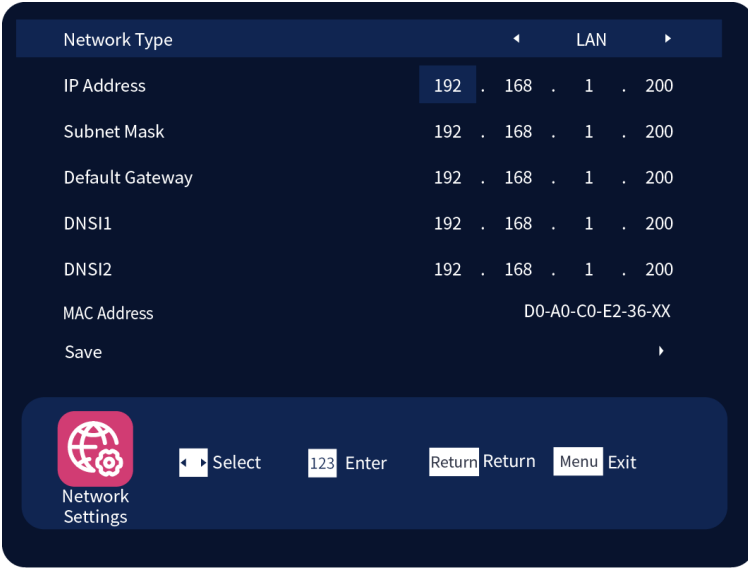

◆ Steps for Specific Configuration:

IP Address: In the wired LAN mode, users can use the left and right keys to move to the IP section that needs to be set, and use the up and down keys to adjust the values. Users can also directly input the desired IP address using the number keys on the remote control. Press the OK button to save it immediately.

① **Subnet Mask:** Same operation as setting the IP address. Move left or right to the value that needs adjustment, use the up and down keys to increase or decrease the value, or input the number directly using the remote control's number keys.

② **Default Gateway:** Configured in the same way as above.

③ **Save Settings:** After completing the IP address configuration, move the cursor (using the left and right keys) to this option. Press the OK button to save the configured network information.

Projector Installation

Settings

■ Menu Settings

◆ Language

Menu Navigation: Go to Menu Settings and select Language. Use the ◀▶ keys to choose the desired language.

◆ Menu Position

This function sets the position of the on-screen menu. Use the ◀▶ keys to select the display position for the on-screen menu.

◆ No Signal Prompt

When there is no signal input, display (On) / do not display (Off) the "No Signal" menu in the center of the screen.

◆ Menu Display Time

If no operation (remote control, network command, serial port command, etc.) occurs within the set time, the menu will automatically exit. Any action in between will interrupt and restart the countdown.

◆ Menu Transparency

When menu transparency is enabled, it won't block the display behind the menu.

◆ Restore Default

Users can choose whether to restore the default settings as needed.

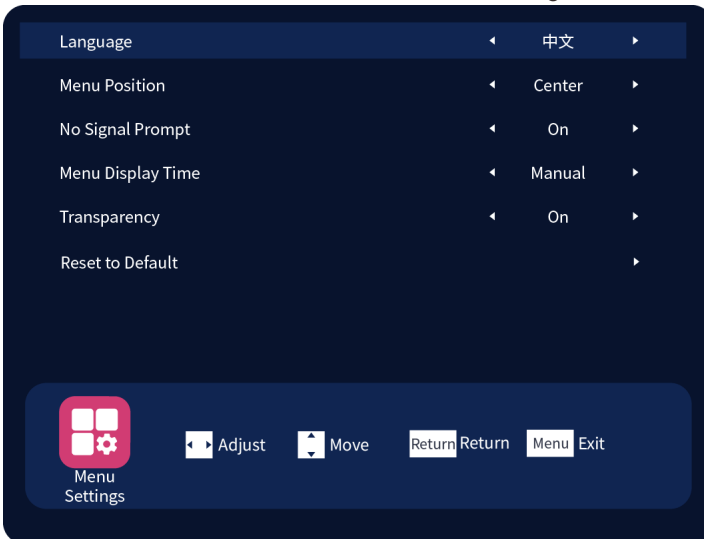

Projector Installation

Settings

■ Operating Mode

- ◆ Set the operation mode to adjust the projector's brightness.

While projecting, go to Settings, select Operating Mode from the menu, and adjust the operation mode using the ◀▶ keys, or you can customize the brightness.

- Standard 100%
- Eco1 50%
- Eco2 30%
- Custom: Adjustable between 30%-100%

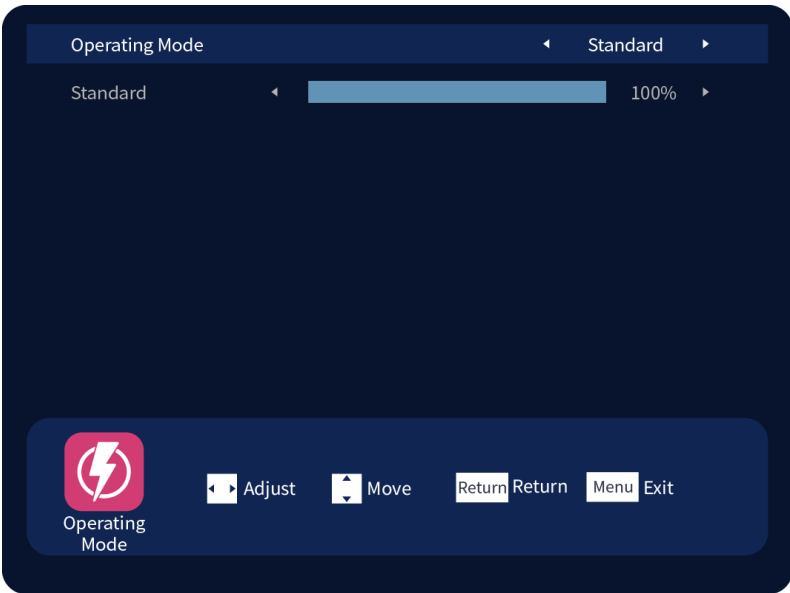

Projector Installation

Settings

■ System Reset

- ◆ While projecting, go to Settings and select System Reset to reset all user menu data (except for total runtime, light source hours, power cycles, and basic device information).

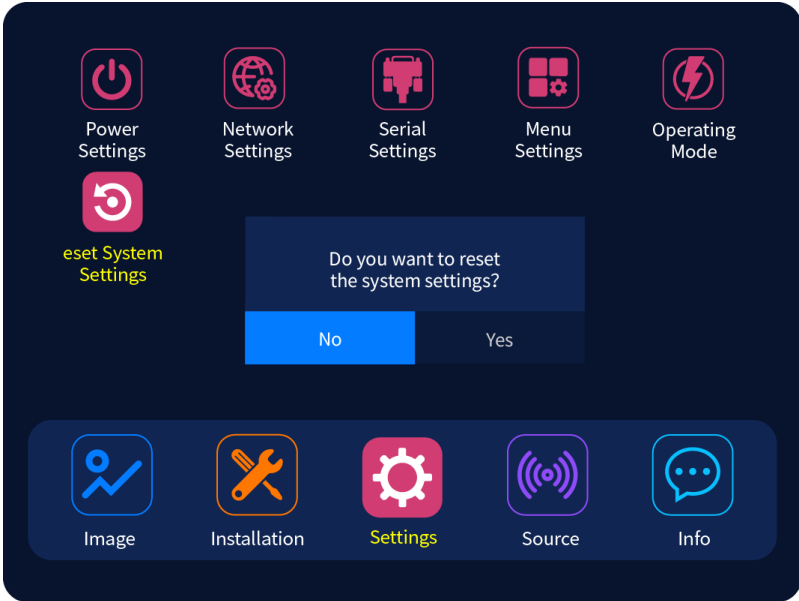

Projector Signal

Signal

■ Signal Settings

- ◆ Choose and change the input signal for the projected image.

Use the remote or control panel to select the menu key, go to [Signal], and enter [Signal Settings]. Choose your signal source (HDMI1, HDMI2, DVI, DP/HDBaseT), and the projector will detect the selected input source and display the image. Signal wake-up is only supported on HDMI1/HDMI2/DVI.

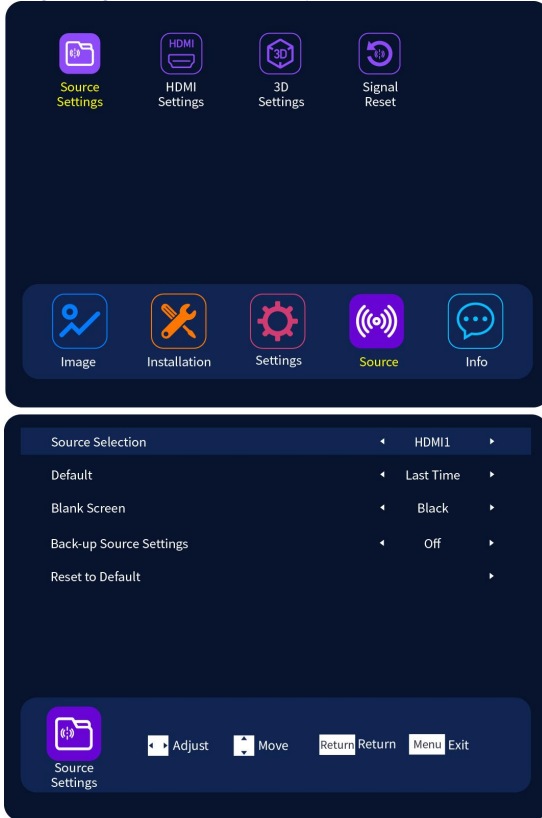

- ◆ **Channel Backup:** Toggle the switch for automatic signal switching between HDMI1 and HDMI2. This function only activates when both HDMI channels have input, and the signal resolution and color space are the same. Switching takes around 300ms. If both channels receive input at the same time, the current selected channel image will display.

Projector Signal

Signal

■ Signal Settings

◆ HDMI Settings

Use the remote or control panel to select the menu key, go to Signal, and enter HDMI Settings to configure color space, level range, and EDID version settings.

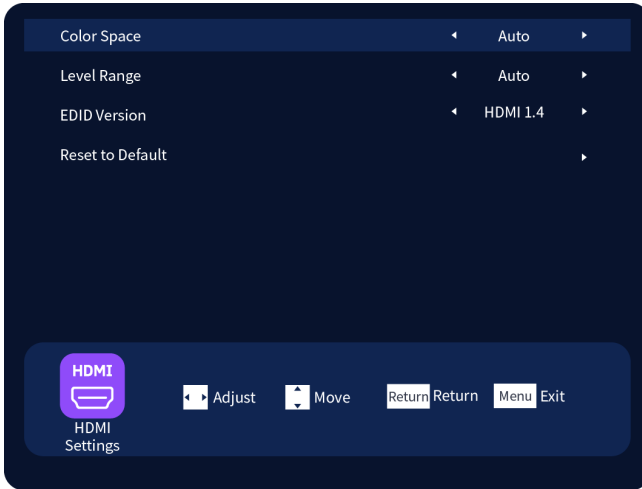

◆ EDID Version

EDID Version	Description
HDMI2.0 HDR	4K image (up to 4096x2160@60Hz), supports high dynamic range EDID.
HDMI2.0 SDR	4K image (up to 4096x2160@60Hz), supports standard dynamic range but not HDR.
HDMI1.4	2K or lower resolution images (up to 1920x1200@60Hz) EDID.

-HDR provides more details, colors, and a wider brightness range compared to SDR, and you can observe the noticeable effects with HDR sources.

-For 3D functionality with 1920x1200@120Hz signal format, please switch to the HDMI channel and select the HDMI 2.0 SDR or HDMI 2.0 HDR EDID version.

Projector Signal

Signal

■ 3D Settings

While projecting, go to the Signal menu, select 3D Settings, and enter the 3D mode settings. Use the arrow keys to choose the desired mode. Once the 3D function is activated, options like aspect ratio, edge blending, installation method, test image, system reset, and channel backup will be unchangeable. To adjust any of these, first disable the 3D mode, configure the settings, and then reactivate the 3D mode.

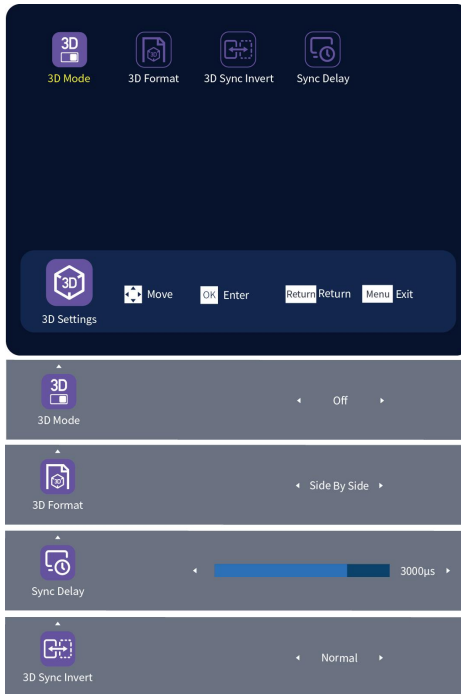

- ◆ 3D Mode: Off (default), Infrared, DLP Link.
- ◆ 3D Format: Side-by-Side (default), Top-Bottom, Frame Sequential, Frame Packing (Blu-ray).
- ◆ L/R Eye Reversal: This function is designed to correct the reversed left and right eye signals that may occur when watching 3D content. This issue typically arises due to mismatched synchronization signals between the 3D device and 3D glasses, which can cause depth perception confusion and eye strain. This function helps correct the issue.
- ◆ Sync Delay: Adjust the delay before displaying each pair of left and right eye images to reduce ghosting or color shifts in 3D viewing.

Projection Information

Information Display

The information display panel is organized into several sections:

- Usage Time:** Projector Time (300000 hr), Light Time (180000 hr), Accumulative Boot (3000 Times).
- Model Information:** Model (AL-SXXKP), SN (T123456780ABC), System Version (4.5.6), Firmware Version (1.2.3).
- Projector ID:** Projector ID (99), Current Source (HDMI1), PN (A70000000306), Resolution (1920x1200@60Hz).
- LAN Status:** LAN (192.168.1.12), Operating Mode (Standard).
- Navigation Bar:** Image, Installation, Settings, Source, Info.

Information Function	Description
Total Usage Time	It displays projector total usage time.
Light Source Time	It displays projector light source usage time.
Power Cycles	Number of times the projector has been powered on/off.
Projector Model	Machine model (sales model production burn-in)
System Version	Hardware system version
Firmware Version	Software version
Projector ID	Projector ID number
Current Input Source	HDMI1/HDMI2/HDBaseT/DVI/DP
Resolution	1920x1200@60Hz / Backup Channel
LAN	It shows device IP if connected, otherwise shows not connected.
Operating Mode	Standard, ECO1, ECO2, Custom

Appendix

Compatible Signal List

- ◆ The table below lists image signals that the projector can display. The projector supports the signals marked with "Y" in the compatibility list.

The content of the signal types includes:

-V: Video Signal

-C: Computer Signal

Signal Format	Resolution	Pixel Clock (Mhz)	Horizontal Scanning Frequency (Khz)	Vertical Scanning Frequency (Hz)	Compatible Signal			
					HDMI1/2	HDBaseT	DVI	DP
C	640*480	25.175	31.47	59.94	Y	Y	Y	Y
	800*600	40.000	37.88	60.32	Y	Y	Y	Y
	1024*768	65.000	48.36	60.00	Y	Y	Y	Y
	1280*768	79.500	47.78	59.87	Y	Y	Y	Y
	1280*800	83.500	49.70	59.81	Y	Y	Y	Y
	1280*960	108.000	60.00	60.00	Y	Y	Y	Y
	1280*1024	108.000	63.98	60.02	Y	Y	Y	Y
	1360*768	85.500	47.71	60.02	Y	Y	Y	Y
	1366*768	85.500	47.71	59.79	Y	Y	Y	Y
	1366*768	72.000	48.00	60.00	Y	Y	Y	Y
	1400*1050	121.750	65.32	59.98	Y	Y	Y	Y
	1440*900	106.500	55.93	59.89	Y	Y	Y	Y
	1600*900	108.000	60.00	60.00	Y	Y	Y	Y
	1600*1200	162.000	75.00	60.00	Y	Y	Y	Y
	1680*1050	146.250	65.29	59.95	Y	Y	Y	Y
	1920*1080	148.500	67.50	60.00	Y	Y	Y	Y
	1920*1200	154.000	74.04	59.95	Y	Y	Y	Y
	1920*1200	308.000	148.08	119.90	Y	/	/	/
	2560*1440	241.500	88.79	59.95	Y	/	/	/
	2560*1600	268.500	98.71	59.97	Y	/	/	/
3840*2400	592.500	148.10	60.00	Y	/	/	/	
V	480p	27.027	31.50	60.00	Y	Y	Y	Y
	576p	27.000	31.25	50.00	Y	Y	Y	Y
	720p	74.250	37.50	50.00	Y	Y	Y	Y
	720p	74.250	45.00	60.00	Y	Y	Y	Y
	720p	148.500	67.50	120.00	Y	Y	Y	Y
	1080p	74.250	27.00	24.00	Y	Y	Y	Y
	1080p	74.250	28.13	25.00	Y	Y	Y	Y
	1080p	74.250	33.75	30.00	Y	Y	Y	Y
	1080p	148.500	56.25	50.00	Y	Y	Y	Y
	1080p	148.500	67.50	60.00	Y	Y	Y	Y
	1080p	297.000	135.00	120.00	Y	/	/	/
	3840*2160p	297.000	54.00	24.00	Y	/	/	/
	3840*2160p	297.000	56.25	25.00	Y	/	/	/
	3840*2160p	297.000	67.50	30.00	Y	/	/	/
	3840*2160p	594.000	112.50	50.00	Y	/	/	/
	3840*2160p	594.000	135.00	60.00	Y	/	/	/
	4096*2160p	297.000	54.00	24.00	Y	/	/	/
	4096*2160p	297.000	56.25	25.00	Y	/	/	/
	4096*2160p	297.000	67.50	30.00	Y	/	/	/
	4096*2160p	594.000	112.50	50.00	Y	/	/	/
4096*2160p	594.000	135.00	60.00	Y	/	/	/	

Appendix

3D Compatible Signal List

- ♦ The table below specifies the 3D-compatible image signals that the projector can display.
- ♦ The abbreviations for input format and 3D format have the following meanings:
 - SBS: Side-by-Side format
 - TB: Top-Bottom format
 - FS: Frame Sequential format
 - FP: Frame Packing format

3D format	Resolution	Horizontal Scanning Frequency (Hz)	Vertical Scanning Frequency (KHz)	Pixel Clock (Mhz)	Compatible Signal			
					HDMI1/2	HDBaseT	DVI	DP
SBS	1920x1200	59.94/60	74.5	154	Y	Y	Y	Y
	1920x1200	50	61.75	129	Y	Y	Y	Y
	1920x1080	59.94/60	67.5	148.5	Y	Y	Y	Y
	1920x1080	50	56.25	123	Y	Y	Y	Y
	1280x720	59.94/60	45.00	74.25	Y	Y	Y	Y
	1280x720	50	37.5	62	Y	Y	Y	Y
TB	1920x1200	59.94/60	74.5	154	Y	Y	Y	Y
	1920x1200	50	61.75	129	Y	Y	Y	Y
	1920x1080	59.94/60	67.5	148.5	Y	Y	Y	Y
	1920x1080	50	56.25	123	Y	Y	Y	Y
	1280x720	59.94/60	45.00	74.25	Y	Y	Y	Y
	1280x720	50	37.5	62	Y	Y	Y	Y
FS	1920x1200	120	152.5	317.2	Y	/	/	/
	1920x1200	59.94/60	74.5	154	Y	Y	Y	Y
	1920x1200	50	61.75	129	Y	Y	Y	Y
	1920x1080	120	135	297	Y	/	/	/
	1920x1080	59.94/60	64.8	148.5	Y	Y	Y	Y
	1920x1080	50	56.25	124	Y	Y	Y	Y
	1280x720	120	90.00	148.5	Y	/	/	/
	1280x720	59.94/60	45.00	74.25	Y	Y	Y	Y
FP	1920x2205	23.98/24	54.00	148.5	Y	/	/	/
	1280x1470	50.00	75	148.5	Y	/	/	/
	1280x1470	60.00	90	148.5	Y	/	/	/

Troubleshooting

Fault Diagnosis

■ The Projector Won't Turn On

Cause	Solution
Power cable is not connected	Plug the power cable into the projector's AC input socket, and plug the other end into a power outlet. If the power outlet has a switch, make sure the switch is on.

■ No Image

Cause	Solution
The video signal source is not turned on or connected incorrectly.	Turn on the video signal source and check if the signal cable is properly connected.
The projector is not properly connected to the input signal device	Check the connection.
Input signal is not selected correctly.	Use the remote or control panel to select the correct input signal.

■ Blurry Image

Cause	Solution
The projector lens is not properly focused.	Adjust the focus using the focus ring.
The projector is not properly aligned with the screen.	Adjust the projection angle and direction. If needed, adjust the height or distance of the projector.

■ Remote C. Not Working

Cause	Solution
Low battery.	Replace the batteries.
There are obstacles between the remote and projector.	Remove obstacles.
The distance is too far from the projector.	Stay within 8 meters (26 feet) from the projector.

Troubleshooting

Indicator Lights

- The top cover of the machine has two indicator lights:
 - Power Indicator (PWR LED): Indicates the power status of the device.
 - System Indicator (SYS LED): Indicates the system's operating status.

Power Indicator (PWR LED)			Status
Red	Green	Orange	
Off	Off	Off	No Power Supply
Off	Flash every 500ms	Off	Power-On Preparation Stage
On	Off	Off	Entering Standby Mode
Off	Flash every 200ms	Off	In Power-On Process Stage
Off	On	Off	Powered-On State
Off	Flash every 1000ms	Off	In Power-Off Process
Off	Off	On	Burn-In Mode
Power Indicator /SYS LED			Status
Red	Green	Orange	
Off	Off	Flash every 500ms	Upgrade State
Off	On	Off	Normal Working Condition
2+2(flash*)	Off	Off	Main Controller and DLP Communication Error
2+3(flash*)	Off	Off	Main Controller and IDU Communication Error
2+4(flash*)	Off	Off	Main Controller and LENS Communication Error
2+6(flash*)	Off	Off	System Upgrade Failed
2+8(flash*)	Off	Off	TEC Startup Error
2+9(flash*)	Off	Off	DLP Input Signal Lock Error
2+10(flash*)	Off	Off	Mechanical Shutter Error
3+2(flash*)	Off	Off	DMD Temp. Error
3+3(flash*)	Off	Off	Power Module Temp. Error
3+4(flash*)	Off	Off	Exhaust Outlet Temp. Error
3+6(flash*)	Off	Off	CW Temp. Error
3+7(flash*)	Off	Off	Laser Temp. Error
3+8(flash*)	Off	Off	Red Laser Cold Surface Temp. Error
3+9(flash*)	Off	Off	DMD Cold Surface Temp. Error
3+10(flash*)	Off	Off	Water Pump Malfunction
4+1(flash*)	Off	Off	DLP Timing Error
4+2(flash*)	Off	Off	DLP Pixel Clock Out of Range
4+3(flash*)	Off	Off	DLP VSync Lost/Out of Range
4+4(flash*)	Off	Off	DLP DAD1000 Error
4+5(flash*)	Off	Off	DLP Communication Module 1_0 Error
4+6(flash*)	Off	Off	DLP Laser Hardware Error
4+7(flash*)	Off	Off	DLP PPRF Timeout
4+8(flash*)	Off	Off	DLP ARM7 Initialization Failure
4+10(flash*)	Off	Off	DLP CW Speed Error

Caution

-Flashing Light Patterns:

1-time flashing: The indicator light turns on for 300ms, off for 300ms; "+" indicates a 300ms pause; the sequence ends with a 2-second interval. For example, "2+2" means: flash twice, pause once, flash twice, followed by an interval. The cycle repeats.

Maintenance and Repair Services

Projector Maintenance

The projector needs to be maintained. You need to regularly maintain the projector to keep the lens clean.

Do not disassemble any parts of the projector. To replace with other parts, please contact the dealer.

Cleaning the Lens

You can clean the lens when you find that the lens surface is stained or dusty.

- ◆ Remove dust with a compressed air tank.
- ◆ If there is dust or stain, gently wipe the lens surface with lens tissue or wet soft cloth with some detergent.



- Do not rub the lens with abrasive materials.

Cleaning the Projector Enclosure

- ◆ To remove dirt or dust, please wipe the enclosure with a soft, lint-free cloth.
- ◆ To remove strong dirt or spots, wet the soft cloth with water and neutral pH detergent, and then wipe the enclosure.



- Do not use wax, alcohol, benzene, thinner, or other chemical cleaners as these substances can damage the enclosure.

Projector Storage

If you need to store the projector for a long period of time, follow the instructions below:

- ◆ Ensure that the temperature and humidity of the storage area are within the recommended range for the projector.
- ◆ Retract the adjustment feet.
- ◆ Remove the battery from the remote control.
- ◆ Use the projector's original packaging or equivalent material to package the projector.

Projector Transportation

It is recommended to use the original packaging or equivalent material when transporting the projector.

Overall Dimensions

Overall Dimensions of Projector

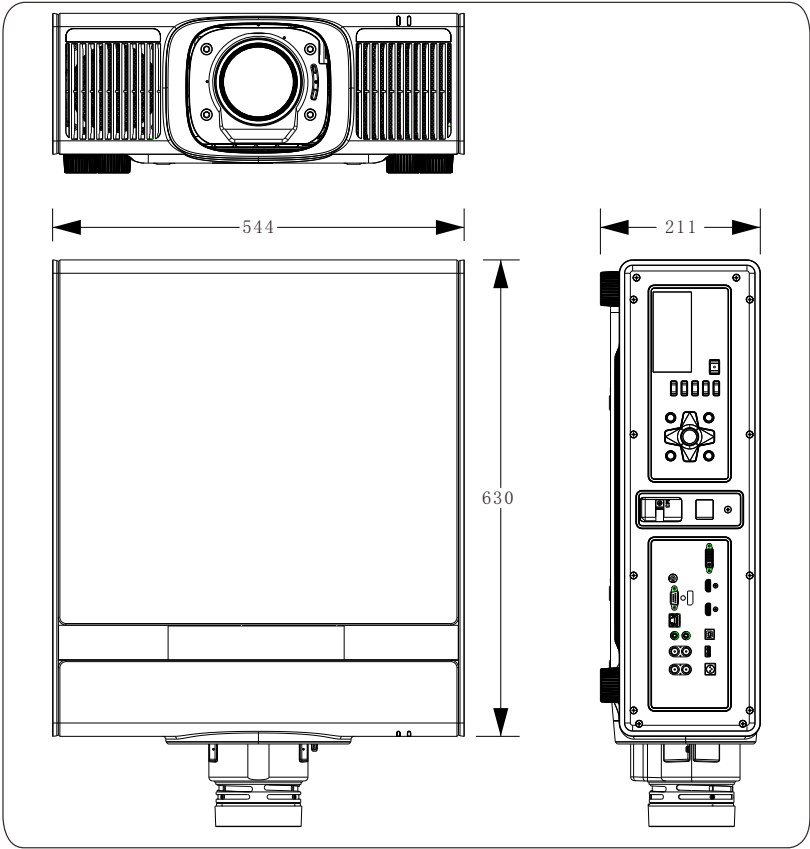

⚠ Caution

- Be sure to use screws of the correct size. The screw length depends on the thickness of the lifting plate.
- Be sure to leave a gap of at least 10cm between the ceiling and the bottom of the projector.
- Do not install the projector near the heat source.



Appotronics Corporation Ltd.

Add: 20-22F, High-Tech Zone Union Tower, No. 63 Xuefu Road, Yuehai Street, Nanshan District, Shenzhen, China

Website: www.appotronics.com

P/N:D66050000368

Version: B