

CLUBWASH MINI

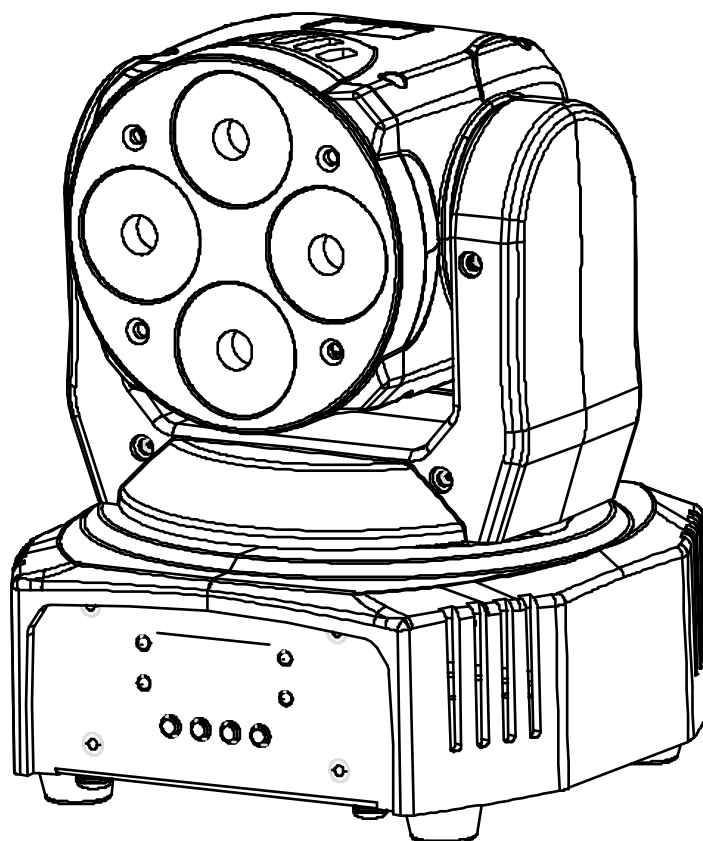

ENGLISH Operation Manual

Other languages can be downloaded from:
WWW.JB-SYSTEMS.EU



Version: 1.0

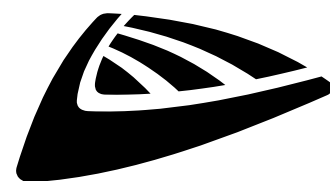

JB SYSTEMS



EN - DISPOSAL OF THE DEVICE

Dispose of the unit and used batteries in an environment friendly manner according to your country regulations.

FR - DÉCLASSER L'APPAREIL

Débarrassez-vous de l'appareil et des piles usagées de manière écologique Conformément aux dispositions légales de votre pays.

NL - VERWIJDEREN VAN HET APPARAAT

Verwijder het toestel en de gebruikte batterijen op een milieuvriendelijke manier conform de in uw land geldende voorschriften.

DU - ENTSORGUNG DES GERÄTS

Entsorgen Sie das Gerät und die Batterien auf umweltfreundliche Art und Weise gemäß den Vorschriften Ihres Landes.

ES - DESHACERSE DEL APARATO

Reciclar el aparato y pilas usadas de forma ecologica conforme a las disposiciones legales de su país.

PT - COMO DESFAZER-SE DA UNIDADE

Tente reciclar a unidade e as pilhas usadas respeitando o ambiente e em conformidade com as normas vigentes no seu país.

OPERATION MANUAL

Thank you for buying this JB Systems® product. To take full advantage of all possibilities and for your own safety, please read these operating instructions very carefully before you start using this unit.

FEATURES

This unit is radio-interference suppressed. This product meets the requirements of the current European and national guidelines. Conformity has been established and the relevant statements and documents have been deposited by the manufacturer.

- A remarkably small and super lightweight moving wash!
- 4 powerful 12W, 6in1 RGBWAUV leds.
- The perfect solution for many applications: DJ's, parties, pubs, ...
- Very low power consumption, only 60 W !
- A real lightweight: only 1,61kg !
- 0-100% dimming and different strobe effects
- Excellent built-in programs for wonderful light shows.
- Multiple working modes:
 - DMX-control: via 5, 9 or 15 channels
 - Standalone: sound activated with internal mic
 - Master/slave: wonderful synchronized lightshows.
- 4-digit LED-display for easy menu navigation

BEFORE USE

- Before you start using this unit, please check if there's no transportation damage. Should there be any, do not use the device and consult your dealer first.
- **Important:** This device left our factory in perfect condition and well packaged. It is absolutely necessary for the user to strictly follow the safety instructions and warnings in this user manual. Any damage caused by mishandling is not subject to warranty. The dealer will not accept responsibility for any resulting defects or problems caused by disregarding this user manual.
- Keep this booklet in a safe place for future consultation. If you sell the fixture, be sure to add this user manual.

Check the contents:

Check that the carton contains the following items:

- Operating instructions
- CLUBWASH MINI
- "Omega bracket" + screws
- Power cable
- IRC remote control

SAFETY INSTRUCTIONS:



CAUTION
RISK OF ELECTRIC SHOCK
DO NOT OPEN



CAUTION: To reduce the risk of electric shock, do not remove the top cover. No user-serviceable parts inside. Refer servicing to qualified service personnel only.



The lightning flash with arrowhead symbol within the equilateral triangle is intended to alert the user or the presence of un-insulated "dangerous voltage" within the product's enclosure that may be of sufficient magnitude to constitute a risk of electric shock.



The exclamation point within the equilateral triangle is intended to alert the user to the presence of important operation and maintenance (servicing) instructions in the literature accompanying this appliance.



This symbol means: indoor use only



This symbol means: Read instructions



This symbol determines: the minimum distance from lighted objects. The minimum distance between light-output and the illuminated surface must be more than 1 meters



The device is not suitable for direct mounting on normally flammable surfaces. (suitable only for mounting on non-combustible surfaces)

RISK GROUP 2
CAUTION:
Do not stare at operating lamp

CAUTION: Do not stare at operating lamp.
May be harmful to the eyes.

- To protect the environment, please try to recycle the packing material as much as possible.
- To prevent fire or shock hazard, do not expose this appliance to rain or moisture.
- To avoid condensation to be formed inside, allow the unit to adapt to the surrounding temperatures when bringing it into a warm room after transport. Condense sometimes prevents the unit from working at full performance or may even cause damages.
- This unit is for indoor use only.
- Don't place metal objects or spill liquid inside the unit. Electric shock or malfunction may result. If a foreign object enters the unit, immediately disconnect the mains power.
- Locate the fixture in a well ventilated spot, away from any flammable materials and/or liquids. The fixture must be fixed at least 50cm from surrounding walls.
- Don't cover any ventilation openings as this may result in overheating.
- Prevent use in dusty environments and clean the unit regularly.
- Keep the unit away from children.
- Inexperienced persons should not operate this device.
- Maximum safe ambient temperature is 40°C. Don't use this unit at higher ambient temperatures.
- Make sure the area below the installation place is free from unwanted persons during rigging, de-rigging and servicing.
- Allow the device about 10 minutes to cool down before to start servicing.
- Always unplug the unit when it is not used for a longer time or before to start servicing.
- The electrical installation should be carried out by qualified personal only, according to the regulations for electrical and mechanical safety in your country.
- Check that the available voltage is not higher than the one stated on the unit.
- The power cord should always be in perfect condition. Switch the unit immediately off when the power cord is squashed or damaged. It must be replaced by the manufacturer, its service agent or similarly qualified persons in order to avoid a hazard.
- Never let the power-cord come into contact with other cables!
- This fixture must be earthed in order to comply with safety regulations.
- Don't connect the unit to any dimmer pack.
- Always use an appropriate and certified safety cable when installing the unit.
- In order to prevent electric shock, do not open the cover. There are no user serviceable parts inside.
- **Never** repair a fuse or bypass the fuse holder. **Always** replace a damaged fuse with a fuse of the same type and electrical specifications!
- In the event of serious operating problems, stop using the fixture and contact your dealer immediately.
- The housing and the lenses must be replaced if they are visibly damaged.

- Please use the original packing when the device is to be transported.
- Due to safety reasons it is prohibited to make unauthorized modifications to the unit.

Important: Never look directly into the light source! Don't use the effect in the presence of persons suffering from epilepsy.

OVERHEAD RIGGING

- **Important:** The installation must be carried out by qualified service personal only. Improper installation can result in serious injuries and/or damage to property. Overhead rigging requires extensive experience! Working load limits should be respected, certified installation materials should be used, the installed device should be inspected regularly for safety.
- Make sure the area below the installation place is free from unwanted persons during rigging, de-rigging and servicing.
- Locate the fixture in a well ventilated spot, far away from any flammable materials and/or liquids. The fixture must be fixed **at least 50cm** from surrounding walls.
- The device should be installed out of reach of people and outside areas where persons may walk by or be seated.
- Before rigging make sure that the installation area can hold a minimum point load of 10times the device's weight.
- Always use a certified safety cable (number 3 on the picture) that can hold 12 times the weight of the device when installing the unit. This secondary safety attachment should be installed in a way that no part of the installation can drop more than 20cm if the main attachment fails.
- The device should be well fixed; a free-swinging mounting is dangerous and may not be considered!
- Don't cover any ventilation openings as this may result in overheating.
- The operator has to make sure that the safety-relating and machine-technical installations are approved by an expert before using them for the first time. The installations should be inspected every year by a skilled person to be sure that safety is still optimal.

1. Fix the omega bracket here with the screws

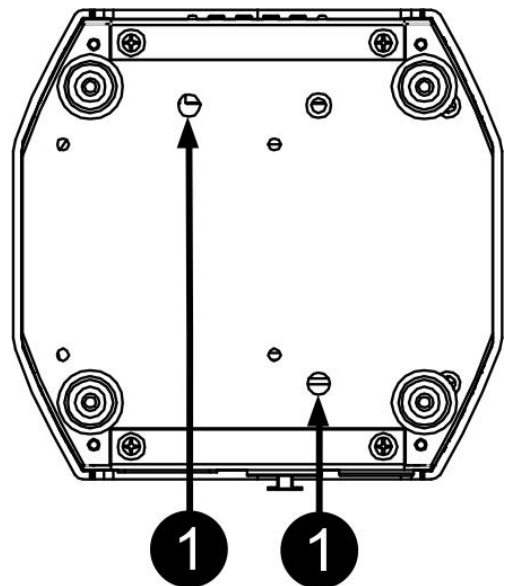

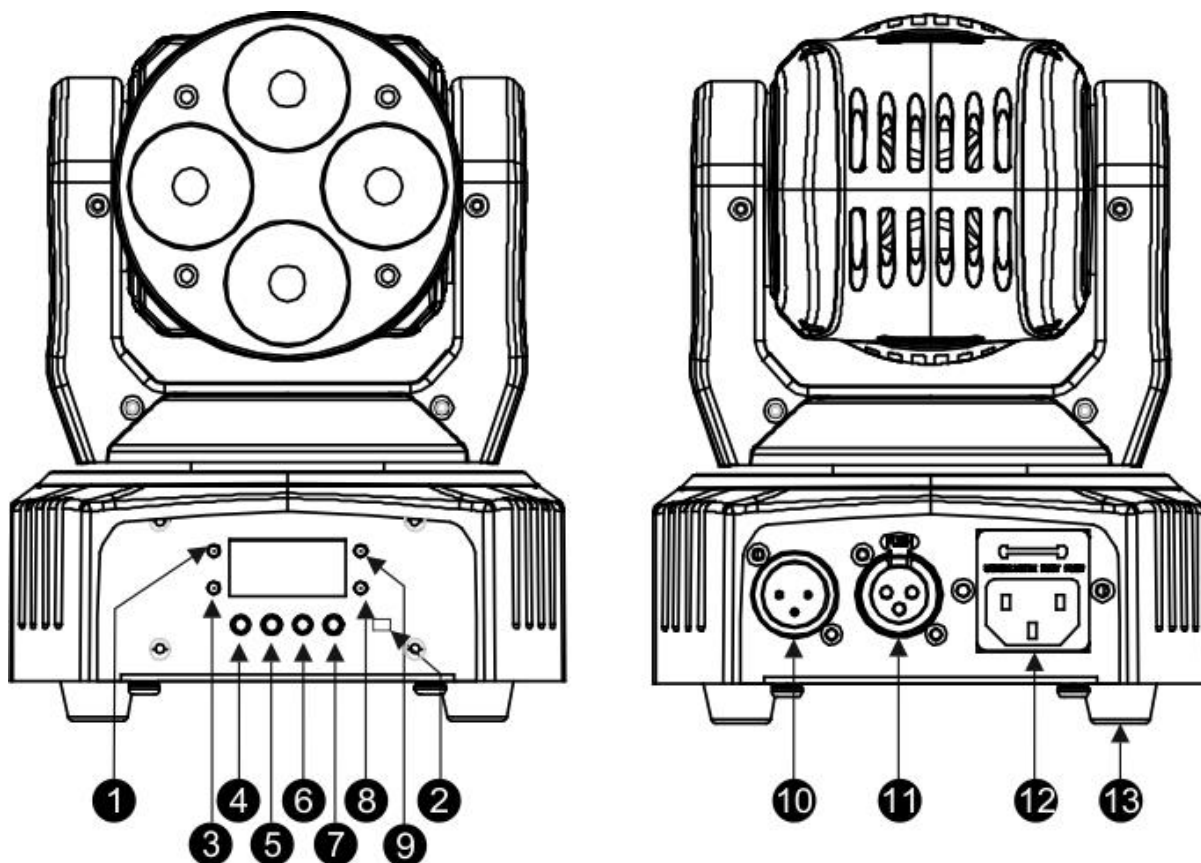
CONTROL PANEL:

1. **[MASTER]** : This LED lits when the CLUBWASH MINI is in Master mode.
2. **IR-REMOTE SENSOR.**
3. **[SOUND]**: This LED reacts to the audio when the CLUBWASH MINI is in sound mode.
4. **[MENU]**: press this button to go back to the main menu or to leave submenus.
5. **[▲]** button : press this button to go up in the menu.
6. **[▼]** button : press this button to go down in the menu.
7. **[ENTER]**: press this button to confirm the selected function in the menu
8. **[SLAVE]**: This LED lits when the CLUBWASH MINI is in Slave mode.
9. **[DMX]**: This LED lits when a DMX-signal is present.
10. **DMX INPUT** connector 3pin XLR Male.
11. **DMX OUTPUT** connector 3p XLR Female.
12. **MAINS INPUT** with IEC14 socket and integrated fuse holder, connect the supplied mains cable here.
13. **RUBBER FOOT.**

MAIN MENU:

- To select any of the pre-set functions, press the [MENU] button up to when the required one is shown on the display.
- Select the function with the [ENTER] button. The display will blink.
- Use ▼ and ▲ button to change the mode.
- Once the required mode has been selected, press the [ENTER] button to confirm. After +/-8 seconds the display will automatically return to the main functions without any change.

To go back to the functions without any change press the [MENU] button. The main functions are shown on the right.

DMX Address

Used to set the starting address in a DMX setup.

- Press the [[MENU]] button until “[Addr]” is shown on the display.
- Press the [ENTER] button, the display starts blinking.
- Use ▼ and ▲ buttons to change the DMX512 address.
- Once the correct address shows on the display, press the [ENTER] button to save it.
(or automatically return to the main functions without any change after 8 seconds)

To go back to the functions without any change press the [MENU] button again.

Channel Mode

- Press the [MENU] button until “[ChMd]” is shown on the display.
- Press the [ENTER] button so the display starts blinking.
- Use ▼ and ▲ button to select the one of the available dmx modes. (5Ch, 9Ch, 15Ch)
- Once the mode is selected, press the [ENTER] button to setup
(Or automatically return to the main functions without any change after 8 seconds.)

To go back to the functions without any change press the [MENU] button again.

Show Mode

Used to choose the Show mode when used in standalone or master/slave mode.

- Press the [MENU] button until “[ShMd]” is shown on the display.
- Press the [ENTER] button, the display starts blinking.
- Use ▼ and ▲ buttons to select “Sh 1”, “Sh 2”, “Sh 3” or “Sh 4” mode.
- Once the right mode shows on the display, press the [ENTER] button to save it.
(or automatically return to the main functions without any change after 8 seconds)

To go back to the functions without any change press the [MENU] button again.

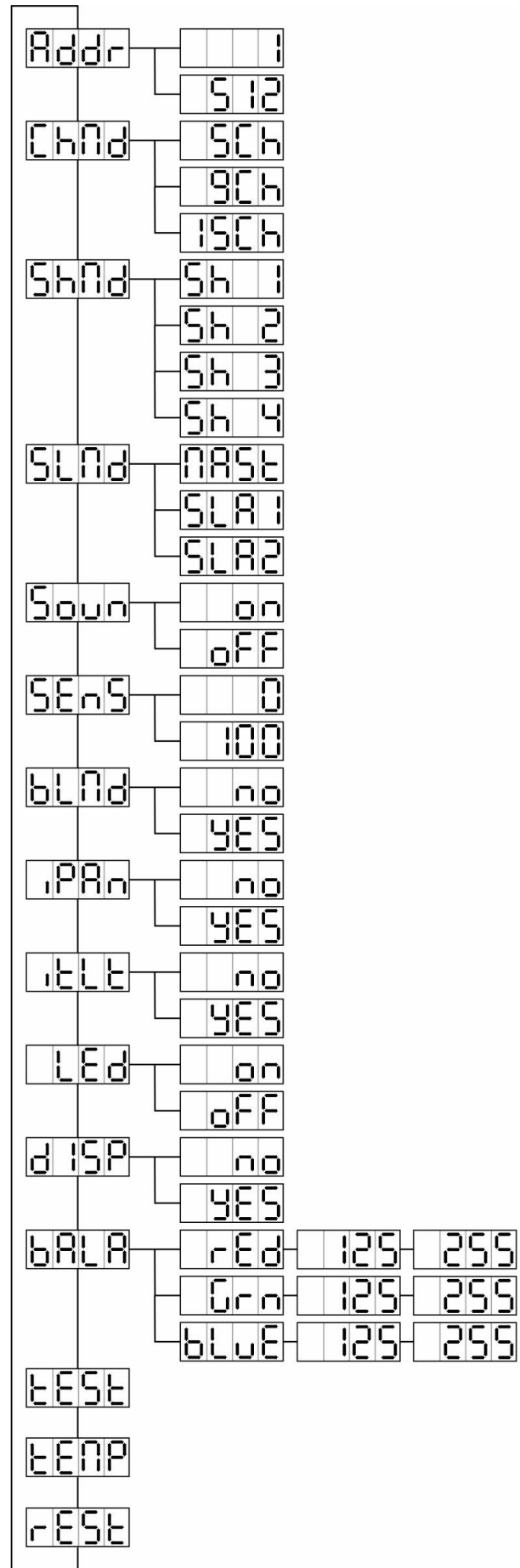

Show 1 mode- Fixture is placed **on the floor**. Tilt movement angle 210°.

Show 2 mode-Fixture is fixed **under ceiling**. Tilt movement angle 90°.

Show 3 mode - Fixture is placed **on the stage, in front of the audience**

The spot is always projecting to the audience's direction; i.e. in front of the stage. Pan movement angle (left to right to left): 160°. Tilt movement angle: 90° (60° above horizon; 30° below horizon.)

Show 4 mode - Fixture is fixed **under ceiling**.

The spot is mainly projecting in front of the stage. Pan movement angle (left to right to left):160°. Tilt movement angle: 90° (vertically, front 75°; back 15°)

Slave Mode

Used to make the slave unit work in opposite to the master or to work in complete sync.

- Press the [MENU] button until "[SIMd]" is shown on the display.
 - Press the [ENTER] button, the display starts blinking.
 - Use ▼ and ▲ button to select "[SL 1]" (normal) or "[SL 2]" (opposite).
 - Once the mode is selected, press the [ENTER] button to save it.
(or automatically return to the main functions without any change after 8 seconds)
- To go back to the functions without any change press the [MENU] button again.

Sound State

The unit works to rhythm of the beat when used in standalone or master/slave mode

- Press the [MENU] button until "[Soun]" is shown on the display.
 - Press the [ENTER] button, the display starts blinking.
 - Use ▼ and ▲ button to select "On" or "Off" mode.
 - Once the mode is selected, press the [ENTER] button save it.
- To go back to the main menu without any change press the [MENU] button shortly.
If you want to go back to normal running mode: press the [MENU] button for about 2 seconds.

Sound Sense

Used to set the sensitivity of the internal microphone

- Press the [MENU] button until "[SEnS]" is shown on the display.
 - Press the [ENTER] button, the display starts blinking.
 - Use ▼ and ▲ button to select a value between "0" (very low sensitivity) and "100" (high sensitivity).
 - Once the mode is selected, press the [ENTER] button save it.
- To go back to the main menu without any change press the [MENU] button shortly.
If you want to go back to normal running mode: press the [MENU] button for about 2 seconds.

Blackout Mode

Blackout mode: when no DMX-signal is detected, the unit goes in blackout and waits for the DMX-signal.

No blackout mode: when no DMX-signal is detected, the unit automatically switches to standalone mode.

- Press the [MENU] button until "[bLMd]" is shown on the display.
 - Press the [ENTER] button, the display starts blinking.
 - Use ▼ and ▲ button to select "[YES]" (yes blackout) or "no" (no blackout) mode.
 - Once the mode has been selected, press the [ENTER] button to save it.
(or automatically return to the main functions without any change after 8 seconds)
- To go back to the functions without any change press the [MENU] button again.

Pan Inversion

Normal: Panning movement is not inverted.

Pan inversion: Panning movement is inverted

- Press the [MENU] button until "[iPan]" is shown on the display.
 - Press the [ENTER] button, the display starts blinking.
 - Use ▼ and ▲ button to select "no" (normal) or "YES" (pan inversion) mode.
 - Once the mode has been selected, press the [ENTER] button to save it.
(or automatically return to the main functions without any change after 8 seconds)
- To go back to the functions without any change press the [MENU] button again.

Tilt Inversion

Normal: Tilt movement is not inverted.

Tilt inversion: tilt movement is inverted

- Press the [MENU] button until “[itLt]” is shown on the display.
- Press the [ENTER] button, the display starts blinking.
- Use ▼ and ▲ buttons to select “no” (normal) or “YES” (tilt inversion) mode.
- Once the mode has been selected, press the [ENTER] button to save it.
(or automatically return to the main functions without any change after 8 seconds)

To go back to the functions without any change press the [MENU] button again.

White balance

It allows the user to fine tune the colors to achieve the perfect white

- Press the [MENU] button until the display shows “[bALA]”.
- Press the [ENTER] button, the display starts blinking.
- If you want to change the default settings, press the ▼ and ▲ buttons to select “RED”, “BLUE” or “GREEN”.
- Press [ENTER] and modify the values to set a specific color temperature, confirm with [ENTER].
(or automatically return to the main functions without any change after 8 seconds)

To go back to the functions without any change press the [MENU] button again.

Test

Used to check all functions of the unit.

- Press the [MENU] button to show “[tEST]” on the display.
- Press the [ENTER] button, the display starts blinking.
- The CLUBWASH MINI will start its auto test program which will show the different colors (RED, GREEN, BLUE, WHITE, AMBER and UV) and does a complete [PAN] and [TILT] movement.

To go back to the main menu press the [MENU] button shortly.

If you want to go back to normal running mode: press the [MENU] button for about 2 seconds.

Temp.

Used to show the temperature inside the unit

- Press the [MENU] button until the display shows “[tEMP].”.
- Press the [ENTER] button to show the internal temperature of the unit on the display.
- To go back to the functions press the [MENU] button again.

If you want to go back to normal running mode: press the [MENU] button for about 2 seconds.

Reset

Used to force a reset of the unit.

- Press the [MENU] button until “[rEST]” is blinking on the display.
- Press the [ENTER] to reset all channels to their standard position.
- To go back to the functions press the [MENU] button.

ELECTRICAL INSTALLATION + ADDRESSING

⚠ Important: The electrical installation should be carried out by qualified personal only, according to the regulations for electrical and mechanical safety in your country.

Every time you turn the unit on, it will show ["Led-RGBUYu"] on the display and move all the motors to their 'home' position and you may hear some noises. After that the unit will be ready to receive DMX signal or run the built-in programs.

YOU CAN OPERATE THE UNIT IN THREE WAYS:

- By master/slave built-in preprogram function
- By universal DMX controller (5CH, 9CH and 15CH DMX mode)
- By IR remote control



• **BY MASTER/SLAVE BUILT-IN PREPROGRAM FUNCTION:**

Select this function when you want an instant show. By linking the units in master/slave connection, the first unit will control the other units to give an automatic, sound activated, synchronized light show. Its DMX input will have nothing plugged into it. The display will indicate "Sh 1, ... Sh 4".

Important! This function only works when the blackout mode in the menu of the master is set to "no", otherwise nothing will happen! Read more about this option in the "Main Menu" paragraph.

- **MASTER has 4 built-in shows:** You can select **show 1, show 2, show 3** or **show 4** directly in the menu of the master.
- **SLAVES have 2 working options:** The other units are set to slave mode. In order to create a great light show you can introduce contrast movements (pan/tilt of slave is inversed) → In the menu of the slave units you can go to option "**SLMd**" and select:
 - "**SLA1**" → **Normal slave:** slave works in sync with the master.
 - "**SLA2**" → **2 light show:** slave works in opposite with the master.

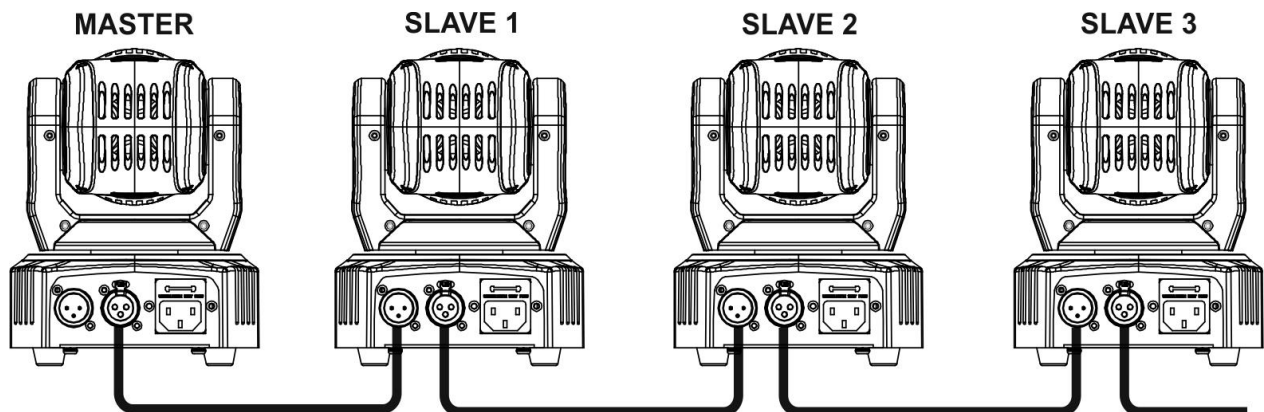

HOW TO CONNECT THE UNIT BY DMX

The DMX-protocol is a widely used high speed signal to control intelligent light equipment. You need to "daisy chain" your DMX controller and all the connected light effects with a good quality XLR M/F balanced cable. To prevent strange behavior of the light effects, due to interferences, you must use a 90Ω to 120Ω terminator at the end of the chain. Never use Y-

Electrical installation for several units on a DMX line:

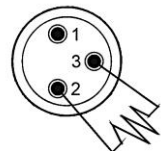

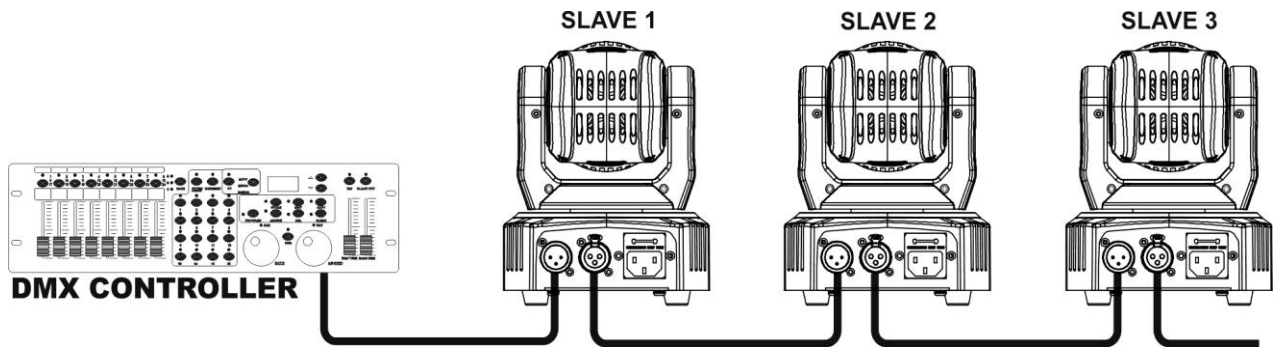

Each light effect in the chain must have its proper starting address so it knows which commands from the controller it has to decode.

HOW TO SET THE RIGHT STARTING ADDRESS:

Refer to the previous chapter (DMX-512 address setting) to learn how to set the starting address on this unit. The starting address of each unit is very important. Unfortunately it is impossible to tell you in this user manual which starting addresses you have to use because this completely depends on the controller you will use... So please refer to the user manual of your DMX-controller to find out which starting addresses you must set.

DMX-CONFIGURATION OF CLUBWASH MINI:

5CH Mode :

DMX Channel	DMX-value	function	remarks
1	000-007	Standby	
	008-255	Dimmer 0 - 100%	
2	000-007	No function	
	008-131	Strobe (slow - fast)	
	132-139	Full on	
	140-181	Close-open	Fast -> slow
	182-189	Full on	
	190-231	Open-close	Fast -> slow
	232-239	Full on	
	240-247	Random strobe	
	248-255	Full on	
	3	000-007	No function
008-037		Colors	Red
038-067			Green
068-097			Blue (dark)
098-127			White
128-157			Orange (Amber)
158-187			UV
188-255		Color fade	Fast -> slow
4	000-015	No function	
	016-200	Pan/Tilt movement	Fast
	201-255	Pan/Tilt movement	Slow
5	000-255	Pan/Tilt Speed	Fast -> slow

9CH Mode :

DMX Channel	DMX-value	function	remarks
1	000-255	Pan	
2	000-255	Tilt	
3	000-199	Dimmer 0 - 100%	
	200-250	Strobe	Slow -> fast
	251-255	Full on	
4	000-255	Red	
5	000-255	Green	
6	000-255	Blue	
7	000-255	White	
8	000-255	Amber	
9	000-255	UV	

15CH Mode :

DMX Channel	DMX-value	function	remarks
1	000-255	Pan	
2	000-255	Pan fine	
3	000-255	Tilt	
4	000-255	Tilt fine	
5	000-255	Pan/Tilt Speed	
6	000-255	Dimmer 0 - 100%	
7	000-255	Red	
8	000-255	Green	
9	000-255	Blue	
10	000-255	White	
11	000-255	Amber	
12	000-255	UV	
13	000-007	No function	
	008-255	Colors	32 pre-defined colors
14	000-007	No function	
	008-131	Strobe from slow to fast	
	132-139	Full on	
	140-181	Strobe effect 1	Fast -> slow
	182-189	Full on	
	190-231	Strobe effect 2	Fast -> slow
	232-239	Full on	
	240-247	Random strobe	
15	000-127	No function	
	128-255	Auto program	

MAINTENANCE

- Make sure the area below the installation place is free from unwanted persons during servicing.
- Switch off the unit, unplug the mains cable and wait until the unit has been cooled down.

During inspection the following points should be checked:

- All screws used for installing the device and any of its parts should be tightly fastened and may not be corroded.
- Housings, fixations and installations spots (ceiling, truss, suspensions) should be totally free from any deformation.
- When an optical lens is visibly damaged due to cracks or deep scratches, it must be replaced.
- The mains cables must be in impeccable condition and should be replaced immediately when even a small problem is detected.
- In order to protect the device from overheat the cooling fans (if any) and ventilation openings should be cleaned monthly.
- The interior of the device should be cleaned annually using a vacuum cleaner or air-jet.
- The cleaning of internal and external optical lenses and/or mirrors must be carried out periodically to optimize light output. Cleaning frequency depends on the environment in which the fixture operates: damp, smoky or particularly dirty surroundings can cause greater accumulation of dirt on the unit's optics.
 - Clean with a soft cloth using normal glass cleaning products.
 - Always dry the parts carefully.

Attention: We strongly recommend internal cleaning to be carried out by qualified personnel!

SPECIFICATIONS

Mains Input:	AC 100 - 240V, 50/60Hz
Power consumption:	60 Watt
Fuse:	250V 3,15A slow blow (20mm glass)
Sound Control:	Internal microphone
DMX connections:	3pin XLR male / female
DMX channels used:	5 / 9 / 15 channels
Lamp:	4x 12W RGBWAUV LEDs
Size:	see drawing below
Weight:	1,61 kg

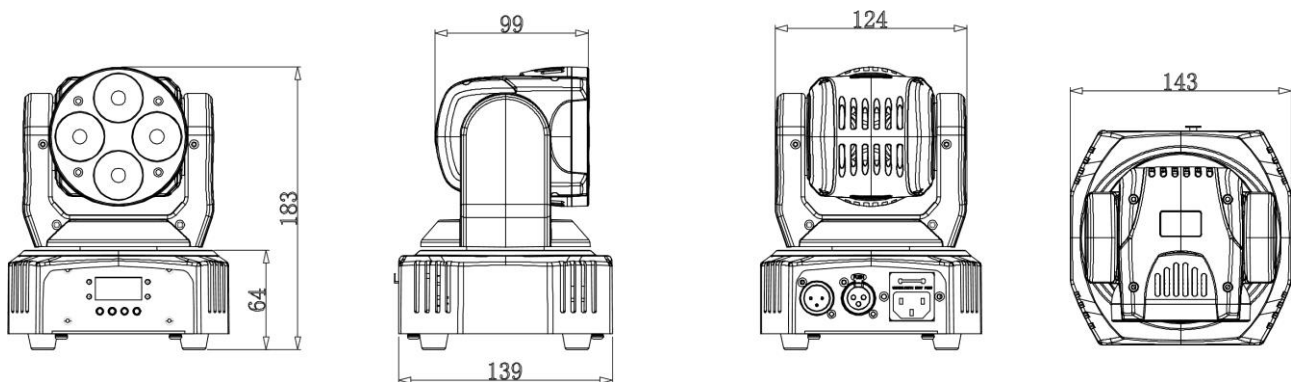

The information might be modified without prior notice

You can download the latest version of this user manual on our website: www.jb-systems.eu



JB SYSTEMS

MAILING LIST

EN: Subscribe today to our mailing list for the latest product news!

FR: Inscrivez-vous à notre liste de distribution si vous souhaitez suivre l'actualité de nos produits!

NL: Abonneer je vandaag nog op onze mailinglijst en ontvang ons laatste product nieuws!

DE: Abonnieren Sie unseren Newsletter und erhalten Sie aktuelle Produktinformationen!

ES: Suscríbete hoy a nuestra lista de correo para recibir las últimas noticias!

PT: Inscreva-se hoje na nossa mailing list para estar a par das últimas notícias!

WWW.JB-SYSTEMS.EU

Copyright © 2019 by BEGLEC NV

t Hofveld 2C ~ B1702 Groot-Bijgaarden ~ Belgium

Reproduction or publication of the content in any manner, without express permission of the publisher, is prohibited.