

LED PAR64FC ZOOM

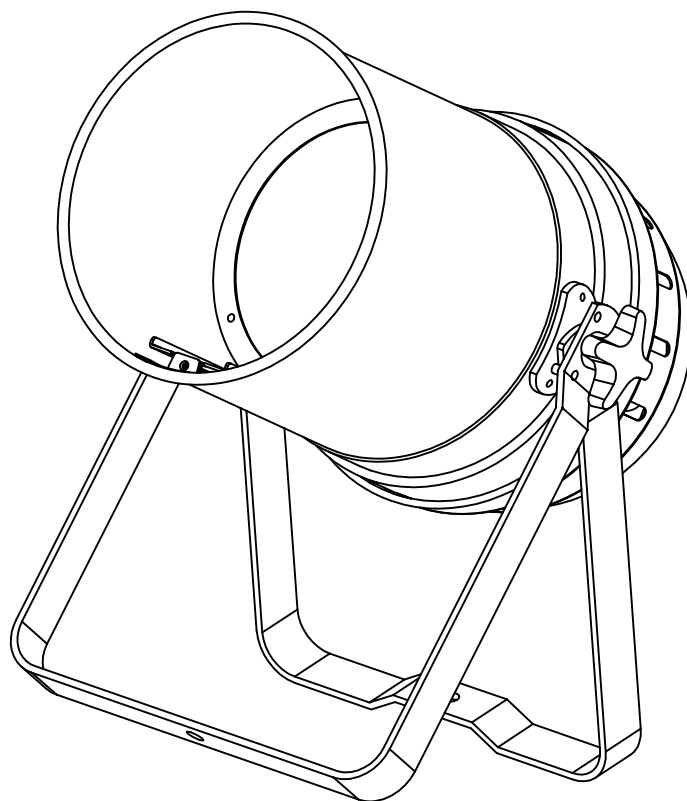

Other languages can be downloaded from:
WWW.JB-SYSTEMS.EU



Version: 1.0

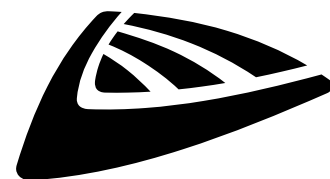

JB SYSTEMS

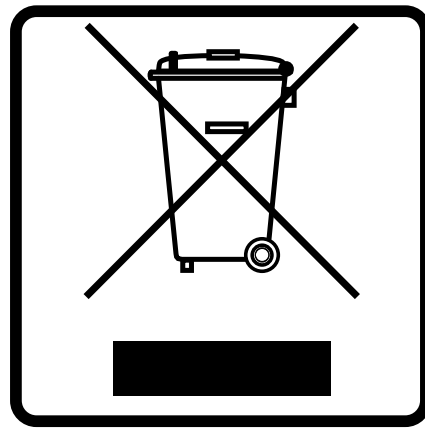

EN - DISPOSAL OF THE DEVICE

Dispose of the unit and used batteries in an environment friendly manner according to your country regulations.

FR - DÉCLASSER L'APPAREIL

Débarrassez-vous de l'appareil et des piles usagées de manière écologique conformément aux dispositions légales de votre pays.

NL - VERWIJDEREN VAN HET APPARAAT

Verwijder het toestel en de gebruikte batterijen op een milieuvriendelijke manier conform de in uw land geldende voorschriften.

DU - ENTSORGUNG DES GERÄTS

Entsorgen Sie das Gerät und die Batterien auf umweltfreundliche Art und Weise gemäß den Vorschriften Ihres Landes.

ES - DESHACERSE DEL APARATO

Reciclar el aparato y pilas usadas de forma ecologica conforme a las disposiciones legales de su país.

PT - COMO DESFAZER-SE DA UNIDADE

Tente reciclar a unidade e as pilhas usadas respeitando o ambiente e em conformidade com as normas vigentes no seu país.

OPERATION MANUAL

Thank you for buying this JB SYSTEMS® product. To take full advantage of all possibilities and for your own safety, please read these operating instructions very carefully before you start using this unit.

FEATURES

- Powerful LED projector with manual zoom!
- PAR 64 housing.
- Equipped with a 150W RGLB COB LED
- IR-remote controller included
- Prepared for wireless DMX: just plug-in an optional WTR-DMX DONGLE ! (Briteq® order code: B04645)
- Different working modes:
 - **Standalone with IR-remote:** automatic or beat synchronized color patterns.
 - **Master/slave mode:** several projectors can be used together for synchronized lightshows.
 - **DMX-controlled:** different channel modes with program selection and individual color control.
- Perfect for mobile applications: low power consumption, high light output.
- Beam angle from 9 to 30° (manual adjustable)
- Many applications possible: Discotheques, DJs, rental companies, ...
- 0-100% dimming and ultra-fast strobe function (no additional strobes needed!)
- OLED-display for easy menu navigation
- Double bracket: easy for use as floor spot !

BEFORE USE

- Before you start using this unit, please check if there's no transportation damage. Should there be any, do not use the device and consult your dealer first.
- **Important:** This device left our factory in perfect condition and well packaged. It is absolutely necessary for the user to strictly follow the safety instructions and warnings in this user manual. Any damage caused by mishandling is not subject to warranty. The dealer will not accept responsibility for any resulting defects or problems caused by disregarding this user manual.
- Keep this booklet in a safe place for future consultation. If you sell the fixture, be sure to add this user manual.

Check the contents:

Check that the packing contains the following items:

- Operating instructions
- LED PAR64FC ZOOM
- IR Remote control
- Power Cable

SAFETY INSTRUCTIONS:



CAUTION
RISK OF ELECTRIC SHOCK
DO NOT OPEN



CAUTION: To reduce the risk of electric shock, do not remove the top cover. No user-serviceable parts inside. Refer servicing to qualified service personnel only.



The lightning flash with arrowhead symbol within the equilateral triangle is intended to alert the user or the presence of un-insulated "dangerous voltage" within the product's enclosure that may be of sufficient magnitude to constitute a risk of electric shock.



The exclamation point within the equilateral triangle is intended to alert the user to the presence of important operation and maintenance (servicing) instructions in the literature accompanying this appliance.



This symbol means: indoor use only



This symbol means: Read instructions



This symbol determines: the minimum distance from lighted objects. The minimum distance between light-output and the illuminated surface must be more than x meters



The device is not suitable for direct mounting on normally flammable surfaces. (suitable only for mounting on non-combustible surfaces)



CAUTION: Do not stare at operating lamp.
May be harmful to the eyes.

- To protect the environment, please try to recycle the packing material as much as possible.
- To prevent fire or shock hazard, do not expose this appliance to rain or moisture.
- To avoid condensation to be formed inside, allow the unit to adapt to the surrounding temperatures when bringing it into a warm room after transport. Condense sometimes prevents the unit from working at full performance or may even cause damages.
- This unit is for indoor use only.
- Don't place metal objects or spill liquid inside the unit. Electric shock or malfunction may result. If a foreign object enters the unit, immediately disconnect the mains power.
- Locate the fixture in a well ventilated spot, away from any flammable materials and/or liquids. The fixture must be fixed at least 50cm from surrounding walls.
- Don't cover any ventilation openings as this may result in overheating.
- Prevent use in dusty environments and clean the unit regularly.
- Keep the unit away from children.
- Inexperienced persons should not operate this device.
- Maximum safe ambient temperature is 40°C. Don't use this unit at higher ambient temperatures.
- Make sure the area below the installation place is free from unwanted persons during rigging, de-rigging and servicing.
- Allow the device about 10 minutes to cool down before to start servicing.
- Always unplug the unit when it is not used for a longer time or before to start servicing.
- The electrical installation should be carried out by qualified personal only, according to the regulations for electrical and mechanical safety in your country.
- Check that the available voltage is not higher than the one stated on the unit.
- The power cord should always be in perfect condition. Switch the unit immediately off when the power cord is squashed or damaged. It must be replaced by the manufacturer, its service agent or similarly qualified persons in order to avoid a hazard.
- Never let the power-cord come into contact with other cables!
- This fixture must be earthed in order to comply with safety regulations.
- Don't connect the unit to any dimmer pack.
- Always use an appropriate and certified safety cable when installing the unit.
- In order to prevent electric shock, do not open the cover. There are no user serviceable parts inside.
- **Never** repair a fuse or bypass the fuse holder. **Always** replace a damaged fuse with a fuse of the same type and electrical specifications!
- In the event of serious operating problems, stop using the fixture and contact your dealer immediately.
- The housing and the lenses must be replaced if they are visibly damaged.
- Please use the original packing when the device is to be transported.
- Due to safety reasons it is prohibited to make unauthorized modifications to the unit.

Important: Never look directly into the light source! Don't use the effect in the presence of persons suffering from epilepsy.

DESCRIPTION:

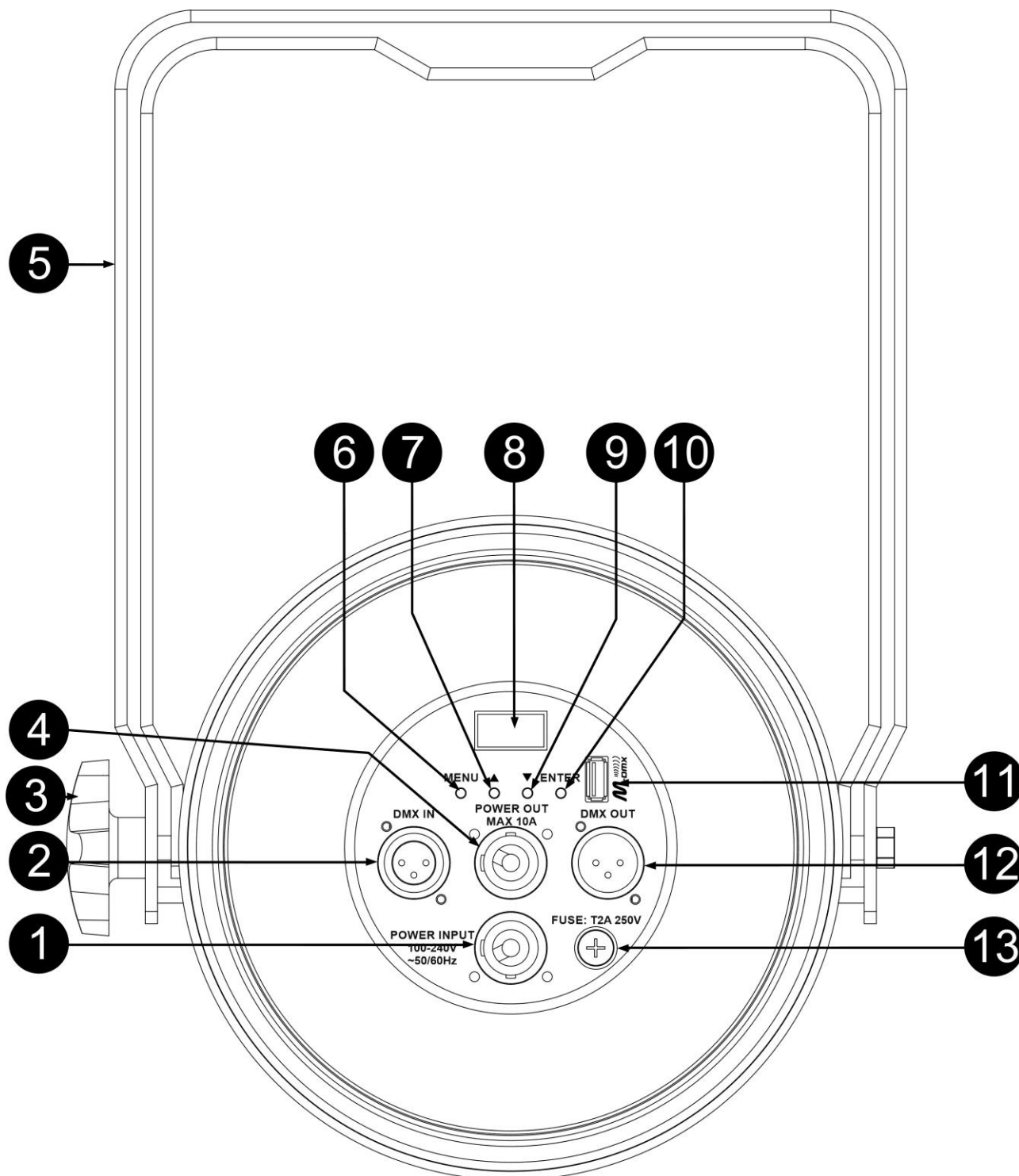

1. **POWER input:** Seetronic SAC3MPA socket, connect the supplied mains cable here.
2. **DMX INPUT:** 3pin male XLR-connector used to connect the projector with the DMX controller or with the previous unit in the DMX chain.
3. **KNOB :** to fasten the double hanging bracket.
4. **POWER output:** Seetronic SAC3MPB socket. Use this to connect this output with the mains input of the next LED PAR64FC ZOOM for easier linking up to 10A.
5. **DOUBLE BRACKET:** with a knob to fasten the unit in the desired position and a mounting hole to fix a truss clamp.
6. **MENU button:** used to browse the different functions in the menu.

7. **▲ button:** to increase the values shown on the display or to go up in the menu.
8. **OLED display :** shows the various menus and the selected functions.
9. **▼ button:** to lower the values shown on the display or to go down in the menu.
10. **ENTER button:** used to confirm your choice or to enter the setup mode of a function.
11. **M-DMX INPUT:** Please note that this USB-connector is NOT used for updates or to connect the unit to a PC! Instead this USB-connector makes it very easy to add wireless DMX to the unit! Just add the (optional) WTR-DMX DONGLE from BRITEQ® and you will get wireless DMX! Moreover you will be able to connect other DMX-controlled equipment to the DMX-output so you can share the wireless DMX function with all connected units! No extra settings to be made in the setup menu, just follow the procedure in the user manual supplied with the WTR-DMX DONGLE from BRITEQ®. *The separate WTR-DMX DONGLE is available from WWW.BRITEQ-LIGHTING.COM (order code: B04645).*
12. **DMX OUTPUT:** 3pin female XLR-connector used to connect the projector with the next unit in the DMX chain.
13. **Fuse holder**

OVERHEAD RIGGING

- **Important:** The installation must be carried out by qualified service personal only. Improper installation can result in serious injuries and/or damage to property. Overhead rigging requires extensive experience! Working load limits should be respected, certified installation materials should be used, the installed device should be inspected regularly for safety.
- Make sure the area below the installation place is free from unwanted persons during rigging, de-rigging and servicing.
- The device should be installed out of reach of people and outside areas where persons may walk by or be seated.
- Before rigging, make sure the installation can hold a minimum point load of 10times the device's weight.
- Always use a certified safety cable that can hold 12times the weight of the device when installing the unit. This secondary safety attachment should be installed in a way that no part of the installation can drop more than 20cm if the main attachment fails.
- The device should be well fixed; a free-swinging mounting is dangerous and may not be considered!
- Don't cover any ventilation openings as this may result in overheating.
- The operator has to make sure that the safety-relating and machine-technical installations are approved by an expert before using them for the first time. The installations should be inspected every year by a skilled person to be sure that safety is still optimal.

ELECTRICAL INSTALLATION

⚠ Important: The electrical installation should be carried out by qualified personal only, according to the regulations for electrical and mechanical safety in your country.

Electrical installation for 1 standalone unit:

- Insert the mains cable. The unit starts working immediately in the last selected mode.
- Refer to chapter HOW TO SETUP to learn how to switch between the different working modes.

Electrical installation for two or more units in master/slave:

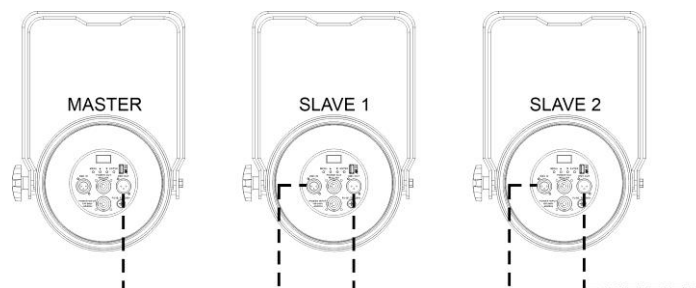

- Connect several units together using DMX- or good quality balanced microphone cables. The unit that has no cable connected to its DMX-input is the "master", the others are the slave units.
- Make sure that all units are connected to the mains.
- Refer to chapter HOW TO SETUP for more information.
- Done!

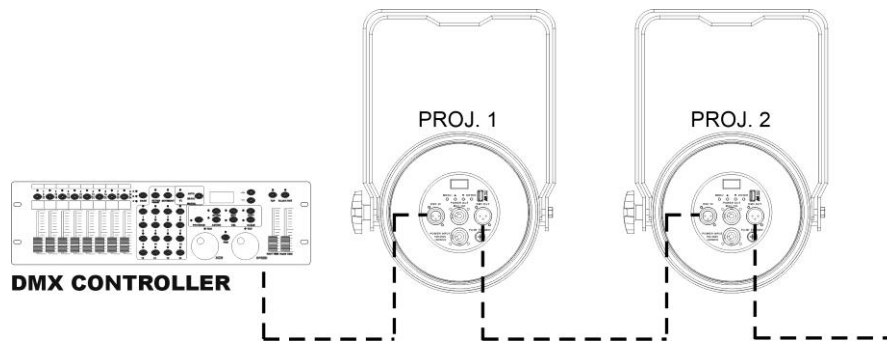
Electrical installation for two or more units in DMX-mode:

- The DMX-protocol is a widely used high speed signal to control intelligent light equipment. You need to “daisy chain” your DMX controller and all the connected units with a good quality balanced cable.
- To prevent strange behavior of the light effects, due to interferences, you must use a 90Ω to 120Ω terminator at the end of the chain. Never use Y-splitter cables, this simply won't work!
- Make sure that all units are connected to the mains.
- Each light effect in the chain needs to have its proper start address so it knows which commands from the controller it has to decode. In the section HOW TO SETUP you will learn how to set the DMX addresses. If for example you use the 4 channel DMX mode, a possible address setup could be: unit1 = 001 ~ unit2 = 005 ~ unit3 = 009 ~ unit4 = 013 ~ etc.

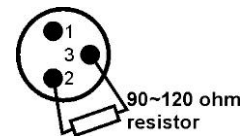
**HOW TO SETUP:**

With the setup menu you can fully configure the projector. All settings are preserved when the unit is disconnected from the mains.

- To select any of the functions, press the MENU button until the required function is shown on the display or use the ▲/▼ buttons to browse the menu.
- Select the function with the ENTER button.
- Use ▲/▼ buttons to change the values.
- Once the required value is selected, press the ENTER button to confirm.

DMX ADDR

Used to set the desired DMX-address.

- Press the MENU button or ▲/▼ buttons until the desired function is showing on the display.
- Press the ENTER button: the DMX value can now be changed
- Use ▲/▼ buttons to select the desired DMX512 address. The last occupied DMX-address is also shown: this makes it easier to set the address of the next unit in the chain.
- Once the correct address shows on the display, press the ENTER button to save it.

Note: on RDM-compatible controllers this option can also be remotely set.

CH. MODE

Used to set the desired channel mode.

- Press the MENU button or ▲/▼ buttons until the desired function is showing on the display.
- Press the ENTER button: the values can be changed
- Use ▲/▼ buttons to select the desired mode:
 - **4RGB+DIM:** R+G+B can be set separately, with combined strobe + master dimmer on CH4.
 - **4CH RGBL:** R+G+B+L can be set separately (no master dimmer or strobe).
 - **5RGBL+DIM:** R+G+B+L can be set separately, with combined strobe + master dimmer on CH5.
 - **6CH:** R+G+B+L can be set separately, with separate master dim & combined strobe/sound channels.
 - **6CH+:** R+G+B+L can be set separately, with separate master dim & strobe channels.
 - **7CH:** R+G+B+L can be set separately, with separate master dim, effect & strobe channels
- Once the correct option shows on the display, press the ENTER button to save it.

Remark: on RDM-compatible controllers this option can also be remotely set.

SLAVE MODE

Used to set the projector as slave in a master/slave setup.

- Press the MENU button or ▲/▼ buttons until the desired function is showing on the display.
- Press the ENTER button

SOUND SENS

Used to set sensitivity of the internal microphone, so the projector reacts in the best condition when in sound controlled mode.

- Press the MENU button or ▲/▼ buttons until the desired function is showing on the display.
- Press the ENTER button: the sensitivity SENS can now be changed
- Use ▲/▼ buttons to select the desired sensitivity. (00 = lowest sensitivity, 31=highest sensitivity)
- Press the ENTER button to confirm your settings

AUTO RUN

Used to run all the internal automatic programs automatically.

- Press the MENU button or ▲/▼ buttons until the desired function is showing on the display.
- Use ▲/▼ buttons to select the desired SP **playback speed** from 01 (very slow) to 99 (fast).
- Once the correct value is shown on the display you have to press the ENTER button to confirm.
- Use ▲/▼ buttons to select the desired R **Repetitions** from R01 (1 repetition) to 10.
- Once the correct value is shown on the display, press the ENTER button to save it.

EFF MODE

Used to set the desired effect mode while used as master.

- Press the MENU button or ▲/▼ buttons until the desired function is showing on the display.
- After 1 second, the last selected effect will start running. The name of the effect is now written on the display
- Press the ENTER button: the values can be changed
- Use ▲/▼ buttons to selected the desired mode:
 - **COL.CH04** (COLOR CHANGE 4) 4 colors change automatically without fading.
 - **COL.CH15** (COLOR CHANGE 15) 15 colors change automatically without fading.
 - **COL.FADE** (COLOR FADE) colors change with a nice fading effect.
- Once the desired option is shown on the display you have to press the ENTER button to confirm.
- Use ▲/▼ buttons to select the desired SP **playback speed** from 01 (very slow) to 99 (fast).
- Once the correct value is shown on the display you have to press the ENTER button to confirm.
- Use ▲/▼ buttons to select the desired F **strobe speed** from 00 (NO strobe) to 99 (fast).
- Once the correct value is shown on the display, press the ENTER button to save it.

STATIC

Used to set the desired fixed color while used standalone without controller or as master in a master/slave configuration : 2 white presets + 6 color presets + 1 custom color.

- Press the MENU button or ▲/▼ buttons until the desired function is showing on the display.
- Press the ENTER button: the values can be changed
- Use DOWN and UP buttons to selected the desired color:
 - **LIME**
 - **BLUE**
 - **CYAN**
 - **GREEN**
 - **YELLOW**
 - **RED**
 - **Color CW** cold white
 - **Color WW** warm white
 - **SET** this is a color that can be set by the user. Follow these steps:
 - Press the ENTER button: the display shows the value (000-255) for RED. (use ▲/▼ buttons)
 - Press the ENTER button: the display shows the value (000-255) for GREEN. (use ▲/▼ buttons)
 - Press the ENTER button: the display shows the value (000-255) for BLUE. (use ▲/▼ buttons)
 - Press the ENTER button: the display shows the value (000-255) for LIME. (use ▲/▼ buttons)
 - Press the ENTER button: the display shows the value (001-099) for F (STROBE). (use ▲/▼ buttons)

- Press the ENTER button to save your setting.

MASTER

Used to set the master dimmer while used as master.

- Press the MENU button or ▲/▼ buttons until the desired function is showing on the display.
- Press the ENTER button: the values can be changed
- Use ▲/▼ buttons to select the desired level for the master dimmer. (please note that the last selected static color will be used to set the value)
- Once you have the desired level, press the ENTER button to save it.

Note: the setting of this option has NO effect while the projector is used as SLAVE or in DMX-mode.

WHITEBAL

Used to set the white balance or to perfectly match the colors of several projectors.

- Press the MENU button or ▲/▼ buttons until the desired function is showing on the display.
- Press the ENTER button: the display shows the value (050-255) for RED. (change with ▲/▼ buttons)
- Press the ENTER button: the display shows the value (050-255) for GREEN. (change with ▲/▼ buttons)
- Press the ENTER button: the display shows the value (050-255) for BLUE. (change with ▲/▼ buttons)
- Press the ENTER button: the display shows the value (050-255) for LIME. (change with ▲/▼ buttons)
- Once you have set the desired levels, press the ENTER button to save them.

Note: the setting of this option affects all color settings, static colors and DMX-controlled colors.

DIMCURVE

Used to set the dimmer curve of the master dimmer.

- Press the MENU button or ▲/▼ buttons until the desired function is showing on the display.
- Press the ENTER button: the values can be changed
- Use ▲/▼ buttons to selected the desired curve:

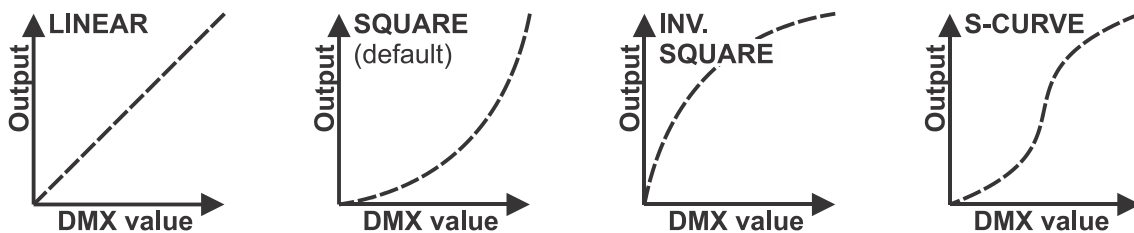

- Once you have the desired curve, press the ENTER button to save it.

BEHAVIOR

Used to select the reaction time of the projector.

- Press the MENU button or ▲/▼ buttons until the desired function is showing on the display.
- Press the ENTER button: the values can be changed
- Use ▲/▼ buttons to select the desired mode:
 - **LED** The projector follows the instructions instantly, no delay.
 - **HALOGEN** The projector imitates the behavior of a halogen lamp (slower reaction time).
- Once the correct option shows on the display, press the ENTER button to save it.

FANSPEED

Used to set the fan working mode.

- Press the MENU button or ▲/▼ buttons until the desired function is showing on the display.
- Press the ENTER button: the values can be changed
- Use ▲/▼ buttons to select the desired mode:
 - **AUTO** Temperature controlled with the focus on maintaining highest possible light output.
 - **STILL** Temperature controlled with the focus on low fan noise (reduced light output when needed).
- Once the correct option shows on the display, press the ENTER button to save it.

LED TEMP

Shows the actual LED temperature.

- Press the MENU button or ▲/▼ buttons until the desired function is showing on the display.

LOCKING

Used to lock the setup menu against unwanted altering of the settings.

- Press the MENU button or ▲/▼ buttons until the desired function is showing on the display.
- Press the ENTER button: the values can be changed
- Use ▲/▼ buttons to select the desired mode:
 - **OFF** The setup menu can be used at any time.
 - **ON** After a short time the setup menu locks automatically, the display shows **LOCKED *******.
Unlock the display by pressing the buttons in this order: **UP, DOWN, UP, DOWN, ENTER**.
- Once the correct option shows on the display, press the ENTER button to save it.

NO DMX

Used to set how the projector reacts when the DMX-signal suddenly disappears.

- Press the MENU button or ▲/▼ buttons until the desired function is showing on the display.
- Press the ENTER button: the values can be changed
- Use ▲/▼ buttons to select the desired mode:
 - **BLACKOUT** output turns black while no DMX is detected.
 - **FREEZE:** output based on the last valid DMX-signal is kept on the projector.
- Once the correct option shows on the display, press the ENTER button to save it.

Note: as soon as the input detects a DMX-signal, blackout or freeze mode will be cancelled.

DEFAULT

This is your emergency exit if you really messed up the settings: just return to factory settings.

Also 2 user settings can be saved/loaded.

- Press the MENU button or ▲/▼ buttons until the desired function is showing on the display.
- Press the ENTER button: the values can be changed
- Use ▲/▼ buttons to selected the desired settings:
 - **FACTORY**
 - **USER1**
 - **USER2**
- Press the ENTER button:
 - **FACTORY** was selected: the display shows **LOAD**
 - Press the ENTER button: the display shows **ACTION?**
 - Use ▲/▼ buttons to select **YES / NO**
 - Press the ENTER button to confirm.
 - **USER1 / USER2** was selected:
 - Use ▲/▼ buttons to select **LOAD / SAVE**
 - Press the ENTER button to confirm: the display shows **ACTION?**
 - Use ▲/▼ buttons to select **YES / NO**
 - Press the ENTER button to confirm.
 - **SAVE** was selected: the current settings of the setup menu are saved to memory.
 - **LOAD** was selected: the previously saved settings are loaded.

Default factory settings:

PARAMETER name	Defaults factory	USER defaults 1	USER defaults 2
DMX Channel mode	6CH	Current setting in the menu	Current setting in the menu
SOUND MODE sensitivity	SENS:25	Current setting in the menu	Current setting in the menu
AUTO RUN Chase repeat	SP=50 R=3	Current setting in the menu	Current setting in the menu
EFFECT MODE	CFADE SP50 F00	Current setting in the menu	Current setting in the menu
CUSTOM Static color	WW 2700K	Current custom color settings	Current custom color settings
MASTER DIM	100%	Current setting in the menu	Current setting in the menu
WHITE BALANCE	RGBL = 255	Current white balance settings	Current white balance settings
DIM Curve	SQUARE	Current setting in the menu	Current setting in the menu
LED behavior	HALOGEN	Current setting in the menu	Current setting in the menu
FANSPEED	AUTO	Current setting in the menu	Current setting in the menu
Auto Lock Menu	OFF	Current setting in the menu	Current setting in the menu
No DMX mode	FREEZE	Current setting in the menu	Current setting in the menu

FIRMWARE

Used to show the current version of the firmware.

- Press the MENU button or ▲/▼ buttons until the desired function is showing on the display.

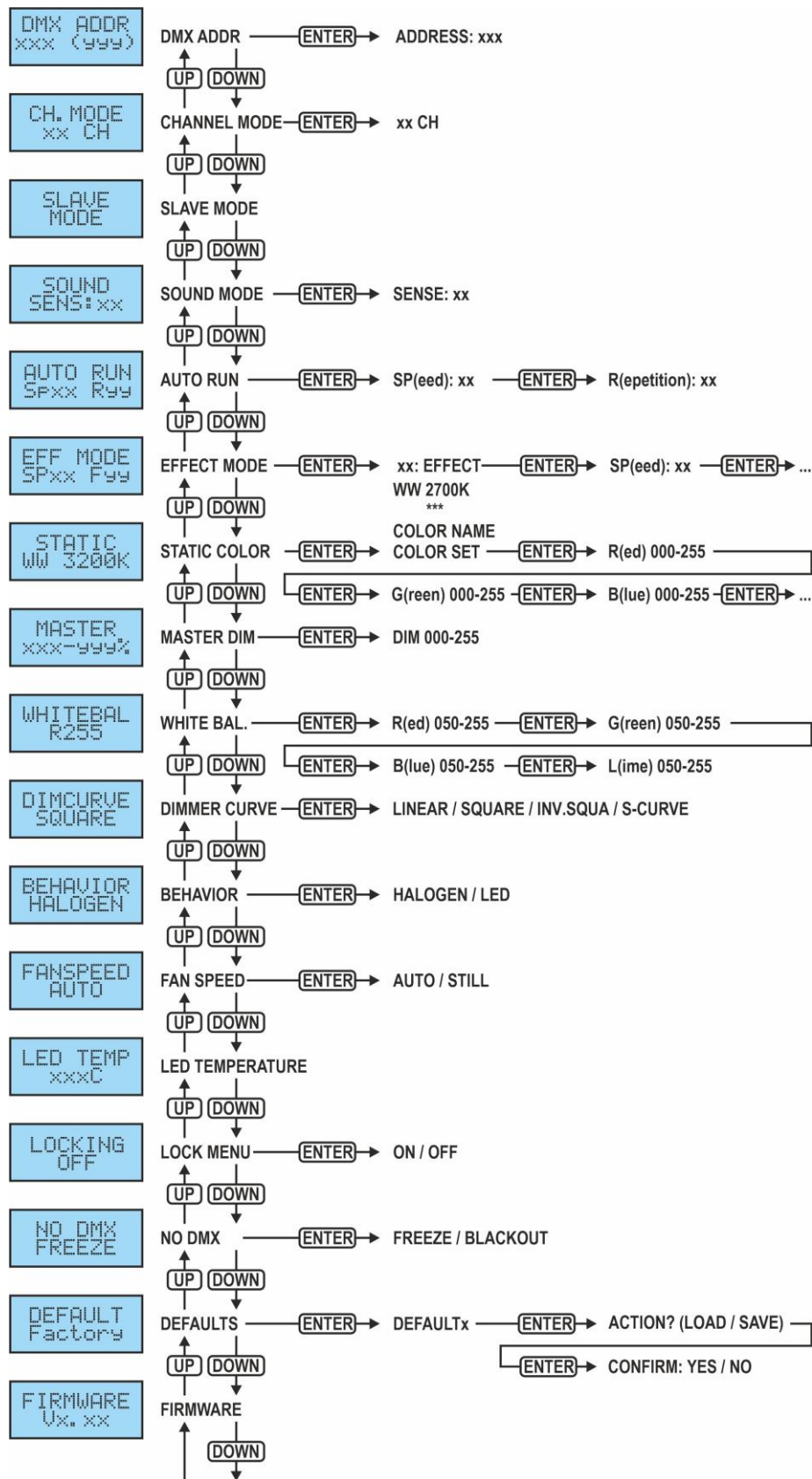

OPERATING INSTRUCTIONS

A. Standalone 1unit:

- Just connect the projector to the mains.
- Select one of the automatic, sound or static color modes
- Refer to chapter HOW TO SETUP to learn how to make the settings.

B. Two or more units in master/slave setup:

- Connect the units together. Refer to the chapter “electrical installation” to learn how to do this.
- Select one of the automatic, sound or static color modes on the master (the first projector in the DMX chain)
- Set all the other projectors in SLAVE mode
- The projectors will now follow the program of the master projector so they all work synchronously.

NOTE: you can use the wireless remote controller to select the functions on the master unit. The slaves will follow.

C. Controlled by the wireless remote controller:

To be able to use the wireless remote control the projector has to be turned on and no DMX should be connected.

Functions:

1. **Battery compartment:** receives a CR2025 3V-battery (supplied).
Note: Maximum distance between the wireless remote and the fixture = +/- 10m
2. **NUMBER buttons:** no function.
3. **+ Button:** used to increase the value of a selected function.
4. **COLOR-buttons:** used to select one of the pre-programmed static colors of the projector.
 - **W (White)**
 - **UV (Ultra Violet – blacklight)**
 - **A (Amber)**
 - **R (Red)**
 - **G (Green)**
 - **B (Blue)**
5. **SL/AU-🎵-button:** used to put the projector in “AUTO-RUN”, sound or “SLAVE” mode. Speed and sensitivity can be adjusted with the “+” and “-“ buttons.
6. **BLACKOUT-button:** used to switch the output ON/OFF
7. **PROG-button:** used to set a static color. With each press you go to the next color. The value of the colors can be adjusted with the “+” and “-“ buttons.
8. **CH-button:** used to set the channel mode of the projctor.
9. **FS/SP-button:** used to switch the strobe function ON/OFF. The speed can be adjusted with the “+” and “-“ buttons. This function only works when the projector is in a static color.
10. **A-button:** used to set the DMX-address of the projector.
11. **- Button:** used to decrease the value of a selected function.

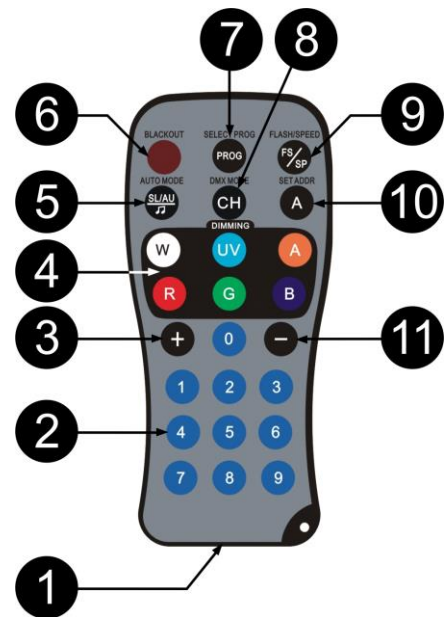

MANUAL ZOOM

The lens can be manually slid forwards and backwards to get the desired beam angle (between 9° and 30° in 9 steps)

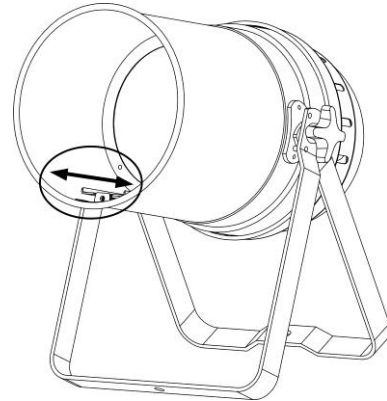

04CH RGB+DIM channel DMX-Mode: RGB + MASTER / DIM / SOUND / STROBE

Channel:	Value:	Function:	Remarks
1	000-255	Red (0-100%)	
2	000-255	Green (0-100%)	
3	000-255	Blue (0-100%)	
4	000-190	Master dimmer	000=0% ~ 190=100% (full open)
	191-200	Sound control (7 colors)	Audio sensitivity: 191=low ~ 200=high
	201-247	Strobe	Increasing speed: 201=slow ~ 247=fast
	248-255	Master dimmer @ 100%	Master dimmer is full open

04CH RGLB channel DMX-Mode: RGLB

Channel:	Value:	Function:	Remarks
1	000-255	Red (0-100%)	
2	000-255	Green (0-100%)	
3	000-255	Blue (0-100%)	
4	000-255	Lime (0-100%)	

05CH RGLB+DIM channel DMX-Mode: RGLB + MASTER/DIM/SOUND/STROBE

Channel:	Value:	Function:	Remarks
1	000-255	Red (0-100%)	
2	000-255	Green (0-100%)	
3	000-255	Blue (0-100%)	
4	000-255	Lime (0-100%)	
5	000-190	Master dimmer	000=0% ~ 190=100% (full open)
	191-200	Sound control (7 colors)	Audio sensitivity: 191=low ~ 200=high
	201-247	Strobe	Increasing speed: 201=slow ~ 247=fast
	248-255	Master dimmer @ 100%	Master dimmer is full open

06CH DMX-Mode: RGLB + MASTER DIM + SOUND/STROBE

Channel:	Value:	Function:	Remarks
1	000-255	Red (0-100%)	
2	000-255	Green (0-100%)	
3	000-255	Blue (0-100%)	
4	000-255	Lime (0-100%)	
5	000-255	Master dimmer (0-100%)	
6	000-004	ON	
	005-024	Sound control (7 colors)	Audio sensitivity: 005=low ~ 024=high
	025-034	ON	
	035-255	Strobe	Increasing speed: 035=slow ~ 255=fast

06CH+ DMX-Mode: RGLB + MASTER DIM + STROBE

Channel:	Value:	Function:	Remarks
1	000-255	Red (0-100%)	
2	000-255	Green (0-100%)	
3	000-255	Blue (0-100%)	
4	000-255	Lime (0-100%)	
5	000-255	Master dimmer (0-100%)	
6	000-004	ON (no strobe)	
	005-255	Strobe	Increasing speed: 005=slow ~ 255=fast

07CH DMX-Mode: MASTER DIM + STROBE + COLOR MACROS + RGLB

Channel:	Value:	Function:	Remarks
1	000-255	Master dimmer (0-100%)	
2	000-007	ON (no strobe)	
	008-037	Random strobe	Increasing speed: 008=slow ~ 037=fast
	038-067	Sound strobe	Increasing sound sensitivity
	068-255	Strobe	Increasing speed: 068=slow ~ 255=fast
3	000-022	No Function	(channels 4+5+6+7 are active)
	023-027	Warm White	
	028-032	Cold White	
	033-037	RED	
	038-042	ORANGE	
	043-047	YELLOW	
	048-052	GREEN	
	053-057	CYAN	
	058-062	BLUE	
	063-067	PURPLE	
	068-072	USER COLOR	
	073-161	Color change	Increasing speed: 083=slow ~ 161=fast
	162-250	Color fade	Increasing speed: 162=slow ~ 250=fast
	251-255	Sound control	
4	000-255	Red (0-100%)	
5	000-255	Green (0-100%)	
6	000-255	Blue (0-100%)	
7	000-255	Lime (0-100%)	

MAINTENANCE

- Make sure the area below the installation place is free from unwanted persons during servicing.
- Switch off the unit, unplug the mains cable and wait until the unit has been cooled down.

During inspection the following points should be checked:

- All screws used for installing the device and any of its parts should be tightly fastened and may not be corroded.
- Housings, fixations and installations spots (ceiling, truss, suspensions) should be totally free from any deformation.
- When an optical lens is visibly damaged due to cracks or deep scratches, it must be replaced.
- The mains cables must be in impeccable condition and should be replaced immediately when even a small problem is detected.
- In order to protect the device from overheat the cooling fans (if any) and ventilation openings should be cleaned monthly.
- The interior of the device should be cleaned annually using a vacuum cleaner or air-jet.
- The cleaning of internal and external optical lenses and/or mirrors must be carried out periodically to optimize light output. Cleaning frequency depends on the environment in which the fixture operates: damp, smoky or particularly dirty surroundings can cause greater accumulation of dirt on the unit's optics.
 - Clean with a soft cloth using normal glass cleaning products.
 - Always dry the parts carefully.

Attention: We strongly recommend internal cleaning to be carried out by qualified personnel!

SPECIFICATIONS

This device carries the prescribed CE marking. It was tested for this purpose in a specialized CE lab and fully complies with all currently valid European and national standards. The corresponding CE conformity declarations can be found on the product page of this product on our website..

Mains Input:	100-240Vac, 50/60Hz
Power consumption:	154 Watt
Fuse:	250V /5A slow blow (20mm glass)
Power linking:	max. linking load = 10A
Sound Control:	Internal microphone
DMX connections:	XLR 3pin Male/Female
DMX modes:	4CH RGB+DIM – 4CH RGLB - 5CH – 6CH – 6CH+ - 7CH
LED Source:	150W RGLB COB LED
Beam angle:	9 to 30°
Size:	47 x 27 x 22cm.
Weight:	3,4 kg

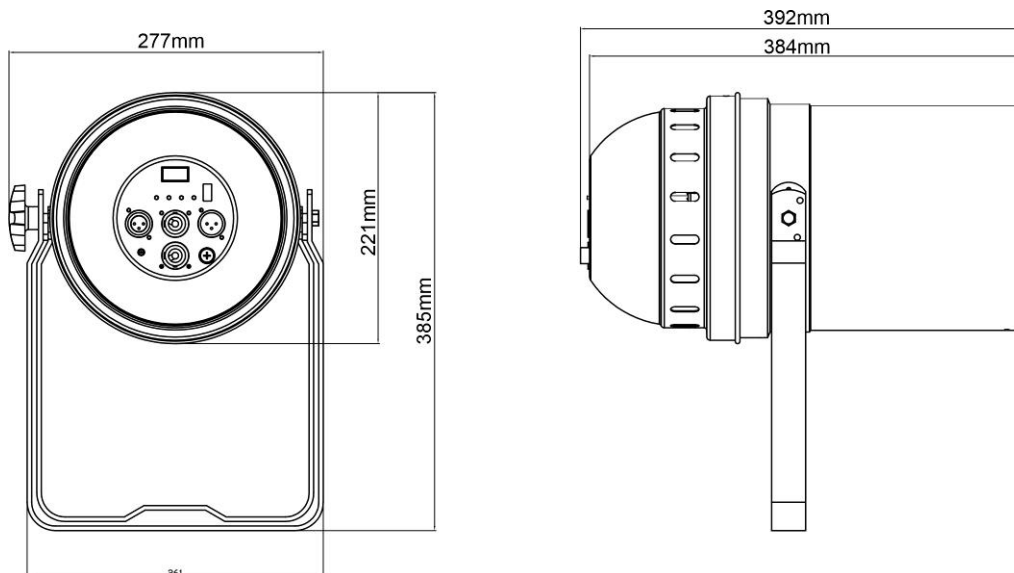

All the information is subject to change without prior notice
You can download the latest version of this user manual on our website: www.jb-systems.eu

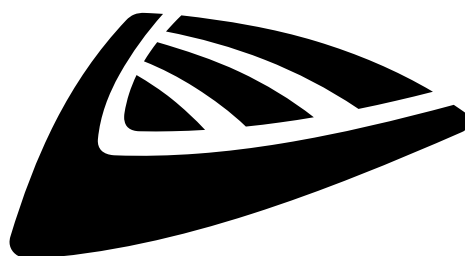

JB SYSTEMS

MAILING LIST

EN: Subscribe today to our mailing list for the latest product news!

FR: Inscrivez-vous à notre liste de distribution si vous souhaitez suivre l'actualité de nos produits!

NL: Abonneer je vandaag nog op onze mailinglijst en ontvang ons laatste product nieuws!

DE: Abonnieren Sie unseren Newsletter und erhalten Sie aktuelle Produktinformationen!

ES: Suscríbete hoy a nuestra lista de correo para recibir las últimas noticias!

PT: Inscreva-se hoje na nossa mailing list para estar a par das últimas notícias!

WWW.JB-SYSTEMS.EU

Copyright © 2024 by BEGLEC NV

't Hofveld 2C ~ B1702 Groot-Bijgaarden ~ Belgium

Reproduction or publication of the content in any manner, without express permission of the publisher, is prohibited.