

# ***BTI-BEAMBAR18***

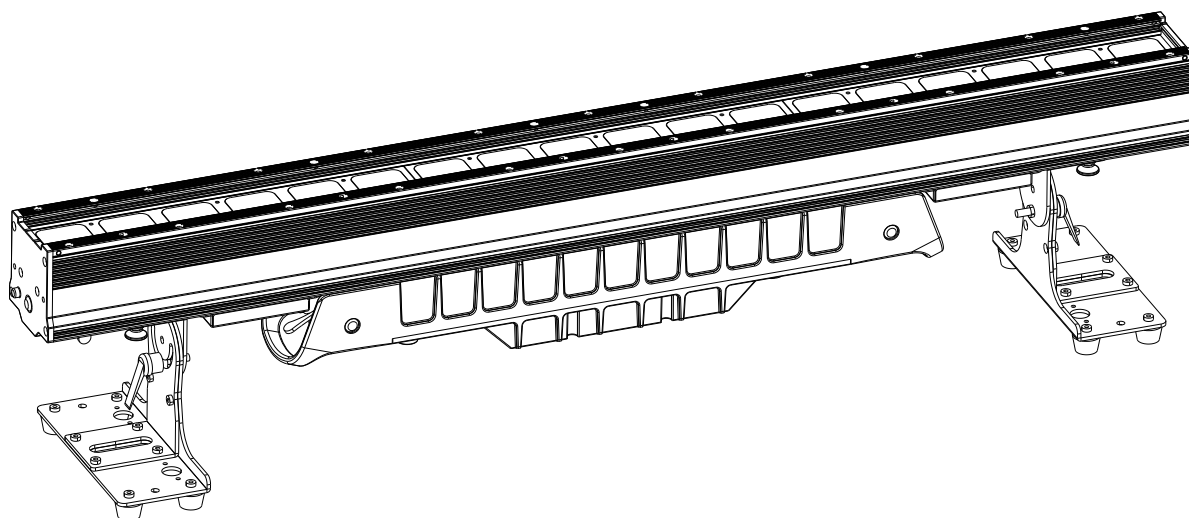

## **ENGLISH**

### **Operation Manual**

Other languages can be downloaded from:  
[WWW.BRITEQ-LIGHTING.COM](http://WWW.BRITEQ-LIGHTING.COM)



*Version: 1.0*



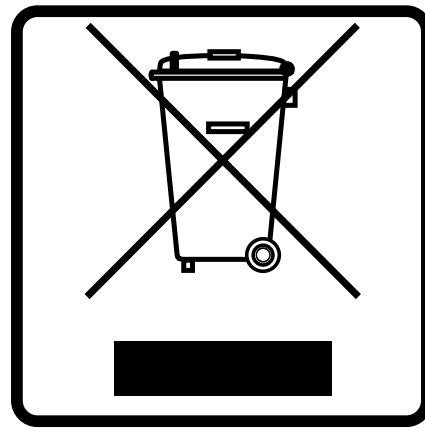

### **EN - DISPOSAL OF THE DEVICE**

Dispose of the unit and used batteries in an environment friendly manner according to your country regulations.

### **FR - DÉCLASSER L'APPAREIL**

Débarrassez-vous de l'appareil et des piles usagées de manière écologique Conformément aux dispositions légales de votre pays.

### **NL - VERWIJDEREN VAN HET APPARAAT**

Verwijder het toestel en de gebruikte batterijen op een milieuvriendelijke manier conform de in uw land geldende voorschriften.

### **DU - ENTSORGUNG DES GERÄTS**

Entsorgen Sie das Gerät und die Batterien auf umweltfreundliche Art und Weise gemäß den Vorschriften Ihres Landes.

### **ES - DESHACERSE DEL APARATO**

Reciclar el aparato y pilas usadas de forma ecologica conforme a las disposiciones legales de su país.

### **PT - COMO DESFAZER-SE DA UNIDADE**

Tente reciclar a unidade e as pilhas usadas respeitando o ambiente e em conformidade com as normas vigentes no seu país.

# OPERATION MANUAL

Thank you for buying this Briteq® product. To take full advantage of all possibilities and for your own safety, please read these operating instructions very carefully before you start using this unit.

## FEATURES

- BTI-BEAMBAR18 is a very versatile **LED Pixel mapping bar**, excellent for many rental jobs, TV-studios, concert stages, discotheques and many more.
- Equipped with 18 extremely effective **6° narrow lenses**, in combination with powerful **25W RGBL LEDs**
- **IP65 protection** for outdoor applications
- The optional magnetic frost filter transforms the fixture a nice wash light
- **Full pixel control through an intuitive effect engine** and/or Art-Net or sACN
- 11, 20, 24, 76 or 96 DMX channels + RDM-functionality for easy remote setup
- Smooth 16bit dimming with adjustable speed and 3 different curves
- Build-in CCT presets from 1700K to 8000K
- Led refresh rate selectable between 1200Hz and 4800Hz
- Quick-lock system to easily mount units horizontally or vertically
- OLED display with touch buttons for easy navigation
- Seetronic IP65 5pin XLR connectors, can be converted to 3pin XLR with our BT-XLR5TO3 kit
- Seetronic IP65 RJ45 connectors for Art-Net and sACN connectivity
- Build in Art-Net to DMX conversion
- Seetronic IP65 TRUE1 compatible power in/outputs
- Software updates through standard RJ45 cable
- Strong tilt brackets with (included) omega brackets for fast installation

## BEFORE USE

- Before you start using this unit, please check if there's no transportation damage. Should there be any, do not use the device and consult your dealer first.
- **Important:** This device left our factory in perfect condition and well packaged. It is absolutely necessary for the user to strictly follow the safety instructions and warnings in this user manual. Any damage caused by mishandling is not subject to warranty. The dealer will not accept responsibility for any resulting defects or problems caused by disregarding this user manual.
- Keep this booklet in a safe place for future consultation. If you sell the fixture, be sure to add this user manual.

### Check the contents:

Check that the packing contains the following items:

- BTI-BEAMBAR18
- 2pcs omega brackets (small)
- English operating instructions, other languages can be downloaded from our website.
- Mains power cable

## SAFETY INSTRUCTIONS:



**CAUTION**  
RISK OF ELECTRIC SHOCK  
DO NOT OPEN



**CAUTION:** To reduce the risk of electric shock, do not remove the top cover. No user-serviceable parts inside. Refer servicing to qualified service personnel only.



The lightning flash with arrowhead symbol within the equilateral triangle is intended to alert the user to the presence of un-insulated "dangerous voltage" within the product's enclosure that may be of sufficient magnitude to constitute a risk of electric shock.



The exclamation point within the equilateral triangle is intended to alert the user to the presence of important operation and maintenance (servicing) instructions in the literature accompanying this appliance.



This Class I appliance must be earthed in order to comply with safety regulations

**IP66**

This unit is fully protected against dust ingress and is also protected against high-pressure water jets from all directions.



This symbol means: Read instructions



This symbol determines: the minimum distance from lighted objects. The minimum distance between light-output and the illuminated surface must be more than 1 meters

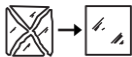

Visibly damaged lenses/housing parts should be replaced with original spare parts.



**CAUTION:** Do not stare at operating light source, this may be harmful to the eyes.

- To protect the environment, please try to recycle the packing material as much as possible.
- To avoid condensation to be formed inside, allow the unit to adapt to the surrounding temperatures when bringing it into a warm room after transport. Condense sometimes prevents the unit from working at full performance or may even cause damages.
- Don't place metal objects or spill liquid inside the unit. Electric shock or malfunction may result. If a foreign object enters the unit, immediately disconnect the mains power.
- Locate the fixture in a well-ventilated spot, away from any flammable materials and/or liquids. The fixture must be fixed at least 50cm from surrounding walls.
- Don't cover any ventilation openings as this may result in overheating.
- Prevent use in dusty environments and clean the unit regularly.
- Keep the unit away from children.
- Inexperienced persons should not operate this device.
- Maximum safe ambient temperature is 40°C. Don't use this unit at higher ambient temperatures.
- Make sure the area below the installation place is free from unwanted persons during rigging, de-rigging and servicing.
- Allow the device about 10 minutes to cool down before to start servicing.
- Always unplug the unit when it is not used for a longer time or before to start servicing.
- The electrical installation should be carried out by qualified personal only, according to the regulations for electrical and mechanical safety in your country.
- Check that the available voltage is not higher than the one stated on the unit.
- The power cord should always be in perfect condition. Switch the unit immediately off when the power cord is squashed or damaged. It must be replaced by the manufacturer, its service agent or similarly qualified persons in order to avoid a hazard.
- Never let the power-cord come into contact with other cables!
- This fixture must be earthed in order to comply with safety regulations.
- Don't connect the unit to any dimmer pack.
- Always use an appropriate and certified safety cable when installing the unit.
- In order to prevent electric shock, do not open the cover. There are no user serviceable parts inside.
- **Never** repair a fuse or bypass the fuse holder. **Always** replace a damaged fuse with a fuse of the same type and electrical specifications!
- In the event of serious operating problems, stop using the fixture and contact your dealer immediately.
- The housing and the lenses must be replaced if they are visibly damaged.
- Please use the original packing when the device is to be transported.
- Due to safety reasons it is prohibited to make unauthorized modifications to the unit.

**Important:** Never look directly into the light source! Don't use the effect in the presence of persons suffering from epilepsy.

## DESCRIPTION:

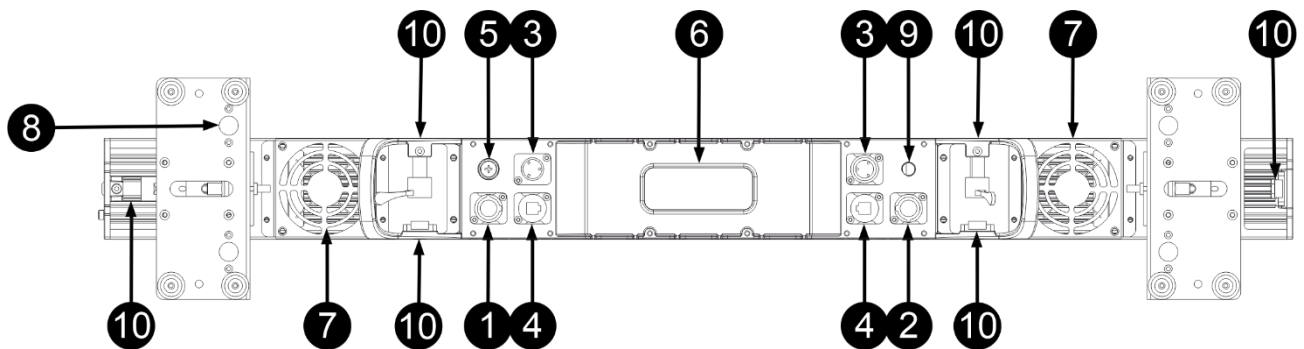

1. **MAINS INPUT:** equipped with PowerCON® TRUE1 compatible connectors. Connect the supplied mains cable or any PowerCon® TRUE1 extension cable here.
2. **MAINS OUTPUT:** used to daisy chain the power to several other projectors. Always pay attention to the maximum load while adding projectors! Special Multi cables (PowerCON® TRUE1 + DMX XLR-cables are optionally available: see our website!)  
*Hint: Please check our website for special cable assemblies that contain both power in one cable. Different lengths are available: 1.3m, 3m, 5m and 10m, very convenient!*
3. **DMX IN/OUT:** 5pin in/outputs are available to daisy chain the projector with other units that will be controlled by a DMX-controller.
4. **ETHERNET IN/OUT:** used to connect the projector to an Ethernet network, Art-Net / sACN protocol is supported.
5. **FUSE:** Holds a 30x6mm T10A250V glass fuse
6. **DISPLAY & BUTTONS:** alphanumeric OLED-display and touch keys to select different options of the setup menu:
  - **MENU-button:** used to browse the different menu options or to exit a menu option. If the setup menu is locked: press the button for about 2seconds to unlock and enter.
  - **▼-button:** used to go to the next menu option or to decrease a parameter value.
  - **▲-button:** used to go to the previous menu option or to increase a parameter value.
  - **ENTER-button:** used to select a menu option or confirm a setting.*Note: shortcut to flip the display → press the ▲+▼ buttons together.*
7. **VENTILLATION HOLES + COOLING FAN:** it is very important to make sure that the temperature-controlled fan and ventilation openings always remain free to maintain optimal cooling!
8. **HANGING BRACKETS:** with a knob to fasten the unit in the desired tilt position. You can use the hole in the center of the bracket to fix a hook or truss clamp. Or you can use the included OMEGA BRACKETS to easily add/remove the truss clamps.
9. **AIR PRESSURE VENT:** for improved performance and service life, this special vent equalizes the pressure inside the projector while blocking water and preventing condense from being formed.
10. **COUPLER MECHANISM:** the coupler mechanism makes it possible to quickly connect and align two or a long line of projectors together. Please proceed as described.

- A. Turn the handle fully to the left
- B. Line the fixtures horizontally or vertically
- C. Push the pin completely through the lock until the pin clicks in place
- D. When this is done, Turn the handle to the right until secure.
- E. To unlock both projectors: repeat point (A) and press the release latch.

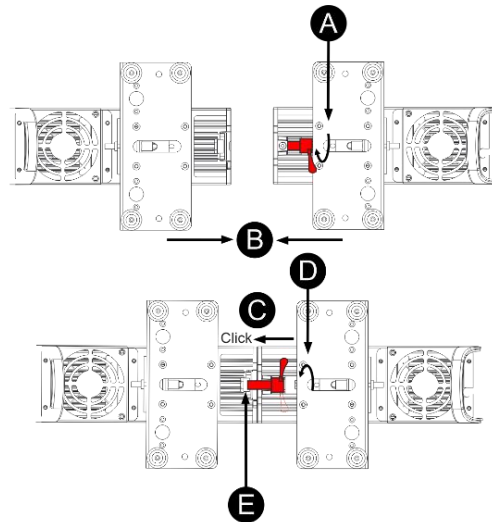

### OVERHEAD RIGGING

- **Important:** The installation must be carried out by qualified service personal only. Improper installation can result in serious injuries and/or damage to property. Overhead rigging requires extensive experience! Working load limits should be respected, certified installation materials should be used, the installed device should be inspected regularly for safety.
- Make sure the area below the installation place is free from unwanted persons during rigging, de-rigging and servicing.
- Locate the fixture in a well-ventilated spot, far away from any flammable materials and/or liquids. The fixture must be fixed at **least 50cm** from surrounding walls.
- The device should be installed out of reach of people and outside areas where persons may walk by or be seated.
- Before rigging make sure that the installation area can hold a minimum point load of 10times the device's weight.
- Always use a certified safety cable that can hold 12times the weight of the device when installing the unit. This secondary safety attachment should be installed in a way that no part of the installation can drop more than 20cm if the main attachment fails.
- The device should be well fixed; a free-swinging mounting is dangerous and may not be considered!
- Don't cover any ventilation openings as this may result in overheating.
- The operator has to make sure that the safety-relating and machine-technical installations are approved by an expert before using them for the first time. The installations should be inspected every year by a skilled person to be sure that safety is still optimal.

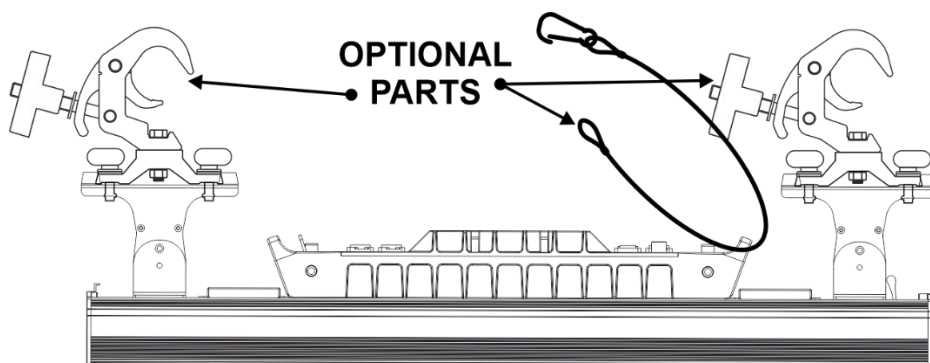
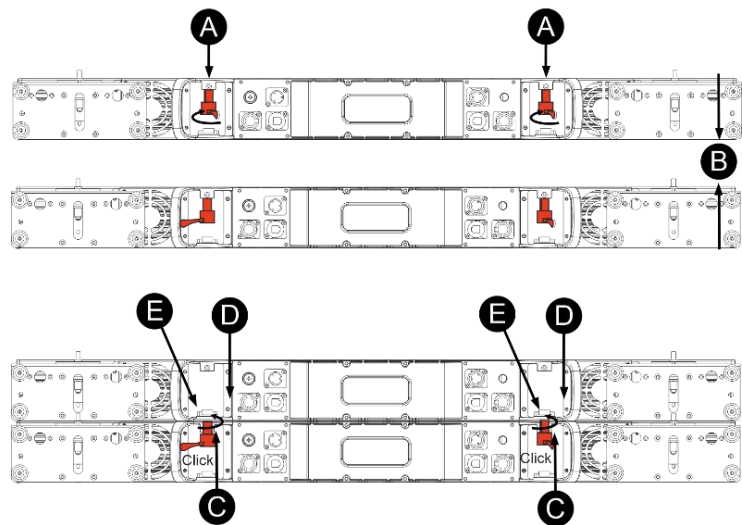

**SETUP MENU:**

Level 0	Level 1	Level 2	Level 3	Default
Set config	Base fixture	Channel mode	Basic	STD 16b
			Standard 8b	
			Standard 16b	
			Pixel	
			Extended	
		Protocol	DMX	DMX
			Art-Net	
			sACN	
		Universe	Universe	001
			Priority*	100
	DMX address	001-512	001	
	Pixel fixture	Pixel DMX mode	Disabled	Disabled
			RGB	
			RGBL	
		Protocol	Art-Net	Art-Net
			sACN	
		Universe	Universe	002
	Priority*		100	
	DMX Address	1-512	001	
	Network	IP Address	Disabled	Custom
			IP: 2.x.x.x	
			IP: 10.x.x.x	
			Custom IP	
	IP Netmask	255.xxx.xxx.xxx		
	Fixture settings	No DMX	Blackout / Freeze	Blackout
		Ethernet to DMX	Yes/No	No
		Fan mode	Silent	Auto
			Auto	
			Full	
		Dimmer curve	Linear	Linear
			Square	
			S-Curve	
Dimmer speed		0-1,5s	0,471s	
Pixel order		Pixel order A	Pixel order A	
		Pixel order B		
White balance		Red		
	Green			
	Blue			
	Lime			
PWM frequency	1200Hz	2400Hz		
	2400Hz			
	3600Hz			

			4800Hz	
		Defaults	Factory load	
			User load	
			User save	
Information	Time info	Total time		
		Last Job Time		
	Temp Info	LED Temp		
	Fan Speed	Fan 1: xxx%		
		Fan 2: xxx%		
	Error Info			
	DMX values	01 Dimmer	xxx	
		02 Dimmer fine	xxx	
...		xxx		
Model Info	BTI-BEAMBAR18			
	0x21220058xxxx			
Firmware version	[Version]			
Manual	Static	Dimmer	xxx	
		...	xxx	
	Disabled			

**General operation of the setup menu:**

- Press the MENU button to ENTER the setup menu.
- Press the ▼/▲ buttons to browse the menu until the required function shows up.
- Select the function with the ENTER button.
- Use ▼/▲ buttons to change the values.
- Press the ENTER button to confirm the selected value.
- Press the MENU button to return to a higher level in the menu or leave the setup menu.

**Remark 1:** On the home screen, press the ▼/▲ buttons to quickly check the current network settings and software version.

**SET CONFIG menu**

**Base fixture**

These DMX settings have effect on the base fixture

**CHANNEL MODE**

Used to set the desired channel mode.

- Press the ▼/▲ buttons to browse the menu until the required function shows up.
- Press the ENTER button: the values can be changed
- Use ▼/▲ buttons to select the desired mode:
  - **Basic:** (11Ch) Basic control of the colors, no effect channels
  - **STD 8b:** (20ch) Basic control of all the functions, pixel control through effect channels
  - **STD 16b:** (24ch) Extended control of all the functions, pixel control through effect channels
  - **Pixel:** (76ch) Individual pixel control of the fixture
  - **Extended:** (96ch) Full control of all functions and individual pixel control
- Once the correct option shows on the display, press the ENTER button to save it.

**Remark:** on RDM-compatible controllers this option can also be remotely set.



**PROTOCOL**

Used to set the desired control mode.

- Press the ▼/▲ buttons to browse the menu until the required function shows up.
- Press the ENTER button: the values can be changed
- Use ▼/▲ buttons to select the control protocol:
  - DMX
  - Art-Net
  - sACN
- Once the correct option shows on the display, press the ENTER button to save it.

**UNIVERSE**

Used to set the desired network universe.

- Press the ▼/▲ buttons to browse the menu until the required function shows up.
- Press the ENTER button: the values can be changed
- Use ▼/▲ buttons to select the desired networked universe. The universe is shown in both decimal and Net/Sub-net values for easy conversion.
- For sACN use ▼/▲ buttons to select the desired priority value.
- Once the correct address shows on the display, press the ENTER button to save it.

**DMX ADDRESS**

Used to set the desired DMX-address.

- Press the ▼/▲ buttons to browse the menu until the required function shows up.
- Press the ENTER button: the values can be changed
- Use ▼/▲ buttons to select the desired DMX512 address. The last occupied DMX-address is also shown: makes it easier to set the address of the next unit in the chain.
- Once the correct address shows on the display, press the ENTER button to save it.

**Note:** on RDM-compatible controllers this option can also be remotely set.

**Pixel fixture**

These DMX settings have effect on the pixel fixture

**Pixel DMX MODE**

Used to set the desired channel mode.

- Press the ▼/▲ buttons to browse the menu until the required function shows up.
- Press the ENTER button: the values can be changed
- Use ▼/▲ buttons to select the desired mode:
  - **Disabled:** Disabled the external pixel control
  - **RGB:** (54ch) Enables external RGB control of the pixels
  - **RGBL:** (72ch) Enables external RGBL control of the pixels
- Once the correct option shows on the display, press the ENTER button to save it.

**PROTOCOL**

Used to set the desired control mode.

- Press the ▼/▲ buttons to browse the menu until the required function shows up.
- Press the ENTER button: the values can be changed
- Use ▼/▲ buttons to select the control protocol:
  - Art-Net
  - sACN
- Once the correct option shows on the display, press the ENTER button to save it.

**UNIVERSE**

Used to set the desired network universe.

- Press the ▼/▲ buttons to browse the menu until the required function shows up.
- Press the ENTER button: the values can be changed
- Use ▼/▲ buttons to select the desired networked universe. The universe is shown in both decimal and Net/Sub-net values for easy conversion.
- For sACN use ▼/▲ buttons to select the desired priority value.
- Once the correct address shows on the display, press the ENTER button to save it.

**DMX ADDRESS**

Used to set the desired DMX-address.

- Press the ▼/▲ buttons to browse the menu until the required function shows up.
- Press the ENTER button: the values can be changed
- Use ▼/▲ buttons to select the desired DMX512 address. The last occupied DMX-address is also shown: makes it easier to set the address of the next unit in the chain.
- Once the correct address shows on the display, press the ENTER button to save it.

**Note:** on RDM-compatible controllers this option can also be remotely set.

**Network**

Used to set the network parameters of the fixture

- Press the ▼/▲ buttons to browse the menu until the required function shows up.
  - IP-mode:
    - 2.x.x.x: This sets the IP address to a random IP in the 2.x.x.x range with subnet-mask 255.0.0.0
    - 10.x.x.x: This sets the IP address to a random IP in the 10.x.x.x range with subnet-mask 255.0.0.0
    - CUSTOM: Use a custom IP address and subnet-mask
- Press the ENTER button: the values can be changed
- Use combination of ▼/▲ and ENTER buttons to set the desired values.

**Fixture settings**

These are the global settings of the fixture

**NO DMX**

Used to set how the fixture reacts when the DMX-signal suddenly disappears.

- Press the ▼/▲ buttons to browse the menu until the required function shows up.
- Press the ENTER button: the values can be changed
- Use ▼/▲ buttons to select the desired mode:
  - **BLACKOUT:** output turns black while no DMX is detected.
  - **FREEZE:** output based on the last valid DMX-signal is kept on the projector.
- Once the correct option shows on the display, press the ENTER button to save it.

**Note:** as soon as the input detects a DMX-signal, blackout or freeze mode will be cancelled.

**Ethernet to DMX**

Enabled/disables the conversion from Art-Net/sACN to DMX on the fixture.

- Press the ▼/▲ buttons to browse the menu until the required function shows up.
- Press the ENTER button: the values can be changed
- Use ▼/▲ buttons to select the desired setting:
  - **Yes:** DMX output enabled.
  - **No:** DMX output disabled.
- Once the correct option shows on the display, press the ENTER button to save it.

**Fan mode**

Selects the desired fan mode.

- Press the ▼/▲ buttons to browse the menu until the required function shows up.
- Press the ENTER button: the values can be changed
- Use ▼/▲ buttons to select the desired setting:
  - **Auto:** Fans are temperature controlled and spin up/down depending on the thermal load.
  - **Silent:** Fans spin at a minimal rate to ensure silent operation. LED power is turned down to prevent overheating.
  - **Full:** Fans spin at full power to ensure the best cooling
- Once the correct option shows on the display, press the ENTER button to save it.

**DIMMER CURVE**

Used to set the dimmer curve of the master dimmer.

- Press the ▼/▲ buttons to browse the menu until the required function shows up.
- Press the ENTER button: the values can be changed

- Use ▼/▲ buttons to selected the desired curve:

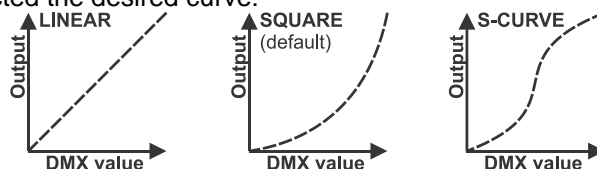

- Once you have the desired curve, press the ENTER button to save it.

### DIMMER SPEED

Used to set the speed (smoothness) of the dimmer continuously.

- Press the ▼/▲ buttons to browse the menu until the required function shows up.
- Press the ENTER button: the values can be changed
- Use ▲/▼ buttons to select the desired speed between 0-1.5s
- Once the desired value shows on the display, press the ENTER button to confirm.

### Pixel order

To keep uniformity, you can flip the pixel order when some projectors are mounted normally and others upside-down (suspended).

- Press the ▼/▲ buttons to browse the menu until the required function shows up.
- Press the ENTER button: the values can be changed
- Use ▼/▲ buttons to select the desired mode:

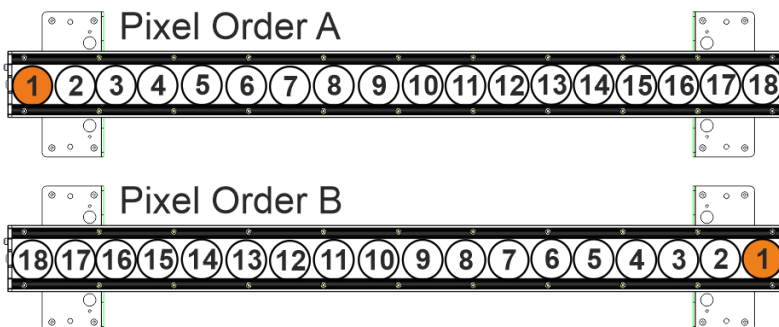

- Once the correct option shows on the display, press the ENTER button to save it.

### WHITE BALANCE

Used to set the white balance.

- Press the ▼/▲ buttons to browse the menu until the required function shows up.
- Press the ENTER button: the display shows the 4 LED colors (change with ▼/▲ buttons)
- Press the ENTER button: the display shows the value (128-255) for the selected color / led.
- Use ▼/▲ buttons to adapt the value between 128 and 255 and confirm with ENTER
- Repeat these steps until you have the desired values. The settings will be automatically saved.

### PWM Frequency

Used to set the PWM refresh frequency of the LED dimming to avoid undesired effects on video recordings.

- Press the ▲/▼ buttons until the desired function is showing on the display.
- Press the ENTER button: the values can be changed
- Use ▲/▼ buttons to select the desired speed:
  - 1200 Hz : slowest PWM frequency.
  - ...
  - 4800 Hz: highest possible PWM frequency,
- Once the desired value shows on the display, press the ENTER button to confirm.

**Remark 1:** please note that the dimmer behavior changes when the PWM frequency is changed so always use the same PWM frequency on all units.

### Display Invert

Used to flip the display (turn it 180°).

- Press the ▼/▲ buttons to browse the menu until the required function shows up.
- Press the ENTER button: the values can be changed

- Use ▼/▲ buttons to select the desired mode:
  - **No:** normal display
  - **Yes:** flipped display.
- Once the correct option shows on the display, press the ENTER button to save it.  
*Remark: a faster shortcut is to press the ▼/▲ buttons together for about 2 seconds.*

### Defaults

**This is your emergency exit if you really messed up the settings: just return to factory settings.**

- Press the ▼/▲ buttons to browse the menu until the required function shows up.
- Press the ENTER button: the values can be changed
- Use ▼/▲ buttons to selected the desired option:
  - **Factory load:** The factory default settings are restored
  - **User load:** Load the saved user settings
  - **User save:** Save the current settings as a user setting

*Remark: the default values are shown in the last column of the SETUP MENU table, see earlier in this manual.*

## Information menu

### Time info

Shows time information of the fixture

#### Total time

**Shows the Total time the projector was switched on, starting from the 1<sup>st</sup> day it was used.**

- Press the ▼/▲ buttons to browse the menu until the required function shows up.
- Press the ENTER button: the TOTAL usage time is shown, this value cannot be reset.

#### Last job time

**Shows the time the fixture was used since last power on**

- Press the ▼/▲ buttons to browse the menu until the required function shows up.
- Press the ENTER button: the TOTAL usage time is shown, this value is reset every time the fixture powers off

### Fan speed

Shows the actual rotation speed of the cooling fan.

- Press the ▼/▲ buttons to browse the menu until the required function shows up.
- Press the ENTER button: the current rotation speed is shown (in RPM)

### Error Info

Shows current error information

- Press the ▼/▲ buttons to browse the menu until the required function shows up.
- Press the ENTER button: current errors are shown.

### DMX Values

Used to monitor the incoming DMX-signals, handy for fault debugging.

- Press the ▼/▲ buttons to browse the menu until the required function shows up.
- Press the ENTER button: you can monitor the incoming DMX-signal, functions and values are displayed.
- Press the ▼/▲ buttons to select the channel that you want to monitor.

### Model info

Shows the RDM label and UID

### Firmware version

Shows the current firmware version

## Manual

Possibility to set the fixture to a fixed color

- Press the ▼/▲ buttons to browse the menu until the required function shows up.
- Press the ENTER button: the values can be changed
- Use ▼/▲ buttons to select the desired mode:
  - **Manual color:** Set a color combination
  - **Disabled:** DMX control
- Once the correct option shows on the display, press the ENTER button to save it.

## ELECTRICAL INSTALLATION



**Important:** The electrical installation should be carried out by qualified personal only, according to the regulations for electrical and mechanical safety in your country.

Mains power is the same for all units but there are different possibilities to connect the data cabling:

### ELECTRICAL INSTALLATION FOR TWO OR MORE UNITS IN WIRED DMX-MODE:

Use this function when you want to control the projectors by any DMX controller.

- Connect the projectors as shown in the drawing below.

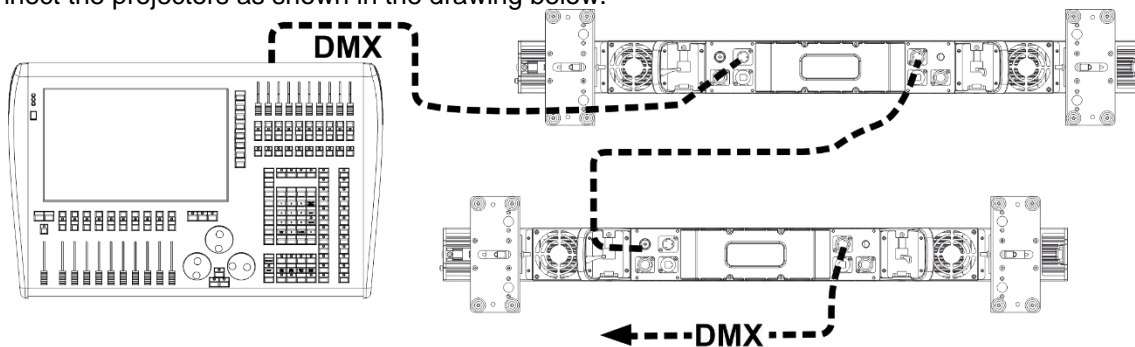

- First put the projectors in the desired DMX-mode: see the different DMX-charts and choose the one that suits you best.
- Give all projectors a start address: each projector shows its start + end address, make sure that the addresses do not overlap!

### **Some general information on DMX:**

- The DMX-protocol is a widely used high speed signal to control intelligent light equipment. You need to “daisy chain” your DMX controller and all the connected units with a balanced cable of good quality.
- Both XLR-3pin and XLR-5pin connectors are used, however XLR-3pin is more popular because these cables are compatible with balanced audio cables.
- Pin layout XLR-3pin: Pin1 = GND ~ Pin2 = Negative signal (-) ~ Pin3 = Positive signal (+)
- Pin layout XLR-5pin: Pin1 = GND ~ Pin2 = Negative signal (-) ~ Pin3 = Positive signal (+) ~ Pins4+5 not used.
- To prevent strange behavior of the light effects, due to interferences, you must use a 90Ω to 120Ω terminator at the end of the chain. Never use Y-splitter cables, this simply won't work!
- Make sure that all units are connected to the mains.
- Each light effect in the chain needs to have its proper starting address so it knows which commands from the controller it has to decode.

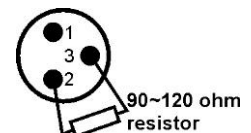

### ELECTRICAL INSTALLATION VIA WIRED ETHERNET IN/OUT:

Art-Net is nothing more than a protocol for transmitting DMX512 over an Ethernet network, developed by Artistic Licence Engineering (UK) Ltd. Thanks to the much bigger bandwidth it is possible to send more than 256 DMX-universes in one time.

This projector can be connected in such Ethernet network using routers, switches etc. The network topology is exactly the same as for a normal PC-network. However, IP-addresses cannot be obtained via DHCP: see the explanations in the chapter “setup menu” on how to manually setup the IP-address, Net Mask and choose the desired DMX-universe. Also the sACN protocol is supported.

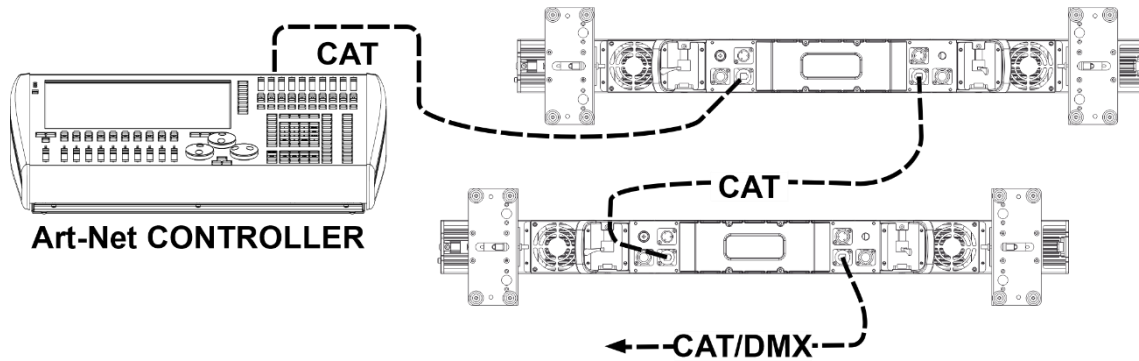

**IMPORTANT NOTE:** this projector has both Ethernet input and output so you can daisy chain several units. However, the number of units in one chain should be limited to  $\pm 10$  units to avoid unwanted signal delays. In bigger installations you should use the “STAR-topology” using Ethernet switches (or a combination of both). This reduces the delays between unit and also improves reliability of the installation.

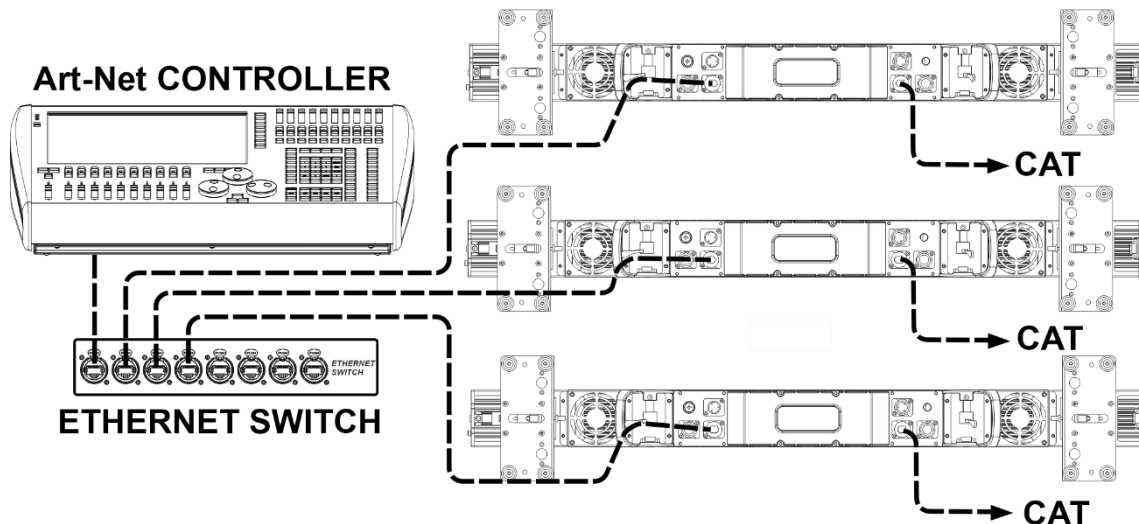

- Internally the selected DMX-universe is treated as a normal DMX-signal so further setup of the DMX-address, channel mode etc. should be done as usual.

**ELECTRICAL INSTALLATION FOR TWO OR MORE UNITS IN COMBINED DMX-MODE:**

Use this function when you want to control the projectors by any DMX controller in combination with an external source for pixel control (e.g. MADRIX)

- Connect the projectors as shown in the drawing below.

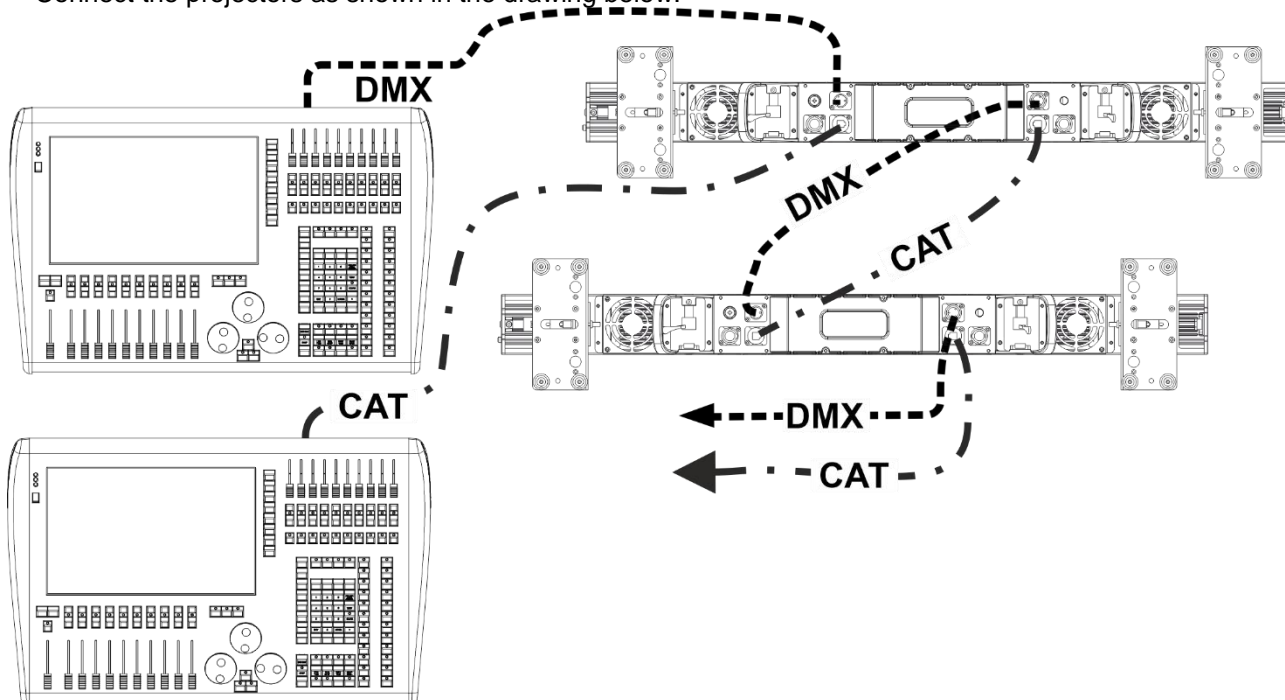

- First put the projectors in the desired DMX-mode: see the different DMX-charts and choose the one that suits you best.
- Give all base and pixel fixtures a start address (& universe): each fixture shows its start + end address, make sure that the addresses do not overlap!
- When using the combined DMX mode, the pixel layer is controlled by the Pixel control channel.

## DMX CHARTS

There are several DMX-modes for maximum compatibility under different conditions:

Basic	STD 8b	STD 16b	Pixel	Extended	Function
1	1	1	1	1	Dimmer
2	2	2	2	2	Dimmer fine
3	3	3	3	3	Shutter
4	4	4	-	4	Red
-	-	5	-	5	Red fine
5	5	6	-	6	Green
-	-	7	-	7	Green fine
6	6	8	-	8	Blue
-	-	9	-	9	Blue fine
7	7	10	-	10	Lime
-	-	11	-	11	Lime fine
8	8	12	-	12	CCT
9	9	13	-	13	Color presets
-	10	14	-	14	Program Red
-	11	15	-	15	Program Green
-	12	16	-	16	Program Blue
-	13	17	-	17	Program Lime
-	14	18	-	18	Effect macros
-	15	19	-	19	Effect rate
	16	20	-	20	Effect width
-	17	21	-	21	Effect fade
10	18	22	-	22	Dimmer speed
-	19	23	4	23	Pixel control
11	20	24	5	24	Control
-	-	-	6	25	Red 1
-	-	-	7	26	Green 1
-	-	-	8	27	Blue 1
-	-	-	9	28	Lime 1
					...
-	-	-	74	93	Red 18
-	-	-	75	94	Green 18
-	-	-	76	95	Blue 18
-	-	-	77	96	Lime 18



Basic	STD 8b	STD 16b	Pixel	Extended	Function	Values		Default values
1	1	1	1	1	Dimmer	0-255		0
2	2	2	2	2	Dimmer fine	0-255		
3	3	3	3	3	Shutter	0-5	Open	0
						6-10	Closed	
						11-85	Random strobe - Combined Pixels	
						86-169	Random strobe - Seperate pixels	
						170-253	Normal Strobe	
						254-255	Open	
4	4	4	-	4	Red	0-255		65535 - 255
-	-	5	-	5	Red fine	0-255		
5	5	6	-	6	Green	0-255		65535 - 255
-	-	7	-	7	Green fine	0-255		
6	6	8	-	8	Blue	0-255		65535 - 255
-	-	9	-	9	Blue fine	0-255		
7	7	10	-	10	Lime	0-255		65535 - 255
-	-	11	-	11	Lime fine	0-255		
8	8	12	-	12	CCT	0-15	Disabled	0
						16-30	8000K	
						31-45	7500K	
						46-60	6500K	
						61-75	6000K	
						76-90	5600K	
						91-105	5000K	
						106-120	4500K	
						121-135	4000K	
						136-150	3500K	
						151-165	3200K	
						166-180	3000K	
						181-195	2700K	
						196-210	2500K	
						211-225	2300K	
226-240	2000K							

						241-255	1800K	
						0-45	Disabled	0
						46-50	Cyan	
						51-55	Yellow	
						56-60	Magenta	
						61-65	Medium Yellow	
						66-70	Straw Tint	
						71-75	Surprise Peach	
						76-80	Fire	
						81-85	Medium Amber	
						86-90	Gold Amber	
						91-95	Dark Amber	
						96-100	Sunrise Red	
						101-105	Light Pink	
						106-110	Medium Pink	
						111-115	Pink Carnation	
						116-120	Light Lavender	
						121-125	Sky Blue	
9	9	13	-	13	Color presets	126-130	Just Blue	
						131-135	Dark yellow green	
						136-140	Spring Yellow	
						141-145	Light Amber	
						146-150	Straw Tint	
						151-155	Deep Amber	
						156-160	Orange	
						161-165	Light Rose	
						166-170	Middle Rose	
						171-175	Dark Pink	
						176-180	Magenta	
						181-185	Peacock Blue	

						186-190	Steel Blue	
						191-195	Light Blue	
						196-200	Dark Blue	
						201-205	Leaf Green	
						206-210	Dark Green	
						211-215	Mauve	
						216-220	Deep Golden Amber	
						221-225	Pale Lavender	
						226-230	Primary Green	
						231-235	Bright Blue	
						236-240	Apricot	
						241-245	Pale Gold	
						246-250	Deep Orange	
						251-255	Flame Red	
-	10	14	-	14	Program Red	0-255		0
-	11	15	-	15	Program Green	0-255		0
-	12	16	-	16	Program Blue	0-255		0
-	13	17	-	17	Program Lime	0-255		0
-	14	18	-	18	Effect macros	0-10	No effect	0
						11-30	Effect 1	
						31-50	Effect 2	
						51-70	Effect 3	
						71-90	Effect 4	
						91-120	Effect 5	
						121-150	Effect 6	
						151-180	Effect 7	
						181-210	Effect 8	
						211-230	Effect 9	

						231-255	Effect 10	
-	15	19	-	19	Effect rate	0-5	Step 1	128
						6-10	Step 2	
						11-15	Step 3	
						16-20	Step 4	
						21-25	Step 5	
						26-30	Step 6	
						31-35	Step 7	
						36-40	Step 8	
						41-45	Step 9	
						46-50	Step 10	
						51-55	Step 11	
						56-60	Step 12	
						61-65	Step 13	
						66-70	Step 14	
						71-75	Step 15	
						76-80	Step 16	
						81-85	Step 17	
						86-90	Step 18	
						91-174	Fwd speed (fast-slow)	
175-176	Stop							
177-255	Bwd speed (slow-fast)							
	16	20	-	20	Effect width	0-15	Effect pixel width: 1	128
						16-30	Effect pixel width: 2	
						31-45	Effect pixel width: 3	
						46-60	Effect pixel width: 4	
						61-75	Effect pixel width: 5	
						76-90	Effect pixel width: 6	
						91-105	Effect pixel width: 7	
						106-120	Effect pixel width: 8	
						121-135	Effect pixel width: 9	
						136-150	Effect pixel width: 10	
						151-165	Effect pixel width: 11	
						166-180	Effect pixel width: 12	
						181-195	Effect pixel width: 13	
						196-210	Effect pixel width: 14	
211-230	Effect pixel width: 15							

						231-245	Effect pixel width: 16	
						246-255	Effect pixel width: 17	
-	17	21	-	21	Effect fade	0-255	Fade between steps	0
10	18	22	-	22	Dimmer speed	0-255	Fast-slow	0
-	19	23	4	23	Pixel control	0-15	DMX control (macros/DMX)	0
						16-238	Mixed mode (crossfade)	
						239-255	ART-NET or sACN mode	
11	20	24	5	24	Control	0-120	No function	0
						121-125	Dim curve: Linear (3s delay)	
						126-130	Dim curve: Square (3s delay)	
						131-135	Dim curve: S-curve (3s delay)	
						136-140	No function	
						141-145	PWM 1200Hz (3s delay)	
						146-150	PWM 2400Hz (3s delay)	
						151-155	PWM 3600Hz (3s delay)	
						156-160	PWM 4800Hz (3s delay)	
						161-165	No function	
						166-170	Pixel order A (3s delay)	
						171-175	Pixel order B (3s delay)	
					176-255	No function		
-	-	-	6	25	Red 1	0-255		255
-	-	-	7	26	Green 1	0-255		255
-	-	-	8	27	Blue 1	0-255		255
-	-	-	9	28	Lime 1	0-255		255
					...			
-	-	-	74	93	Red 18	0-255		255
-	-	-	75	94	Green 18	0-255		255
-	-	-	76	95	Blue 18	0-255		255
-	-	-	77	96	Lime 18	0-255		255

Pixel RGB	Pixel RGLB	Function	Values	Default values
1	1	Red 1	0-255	255
2	2	Green 1	0-255	255
3	3	Blue 1	0-255	255
-	4	Lime 1	0-255	255
		...		
52	69	Red 18	0-255	255
53	70	Green 18	0-255	255
54	71	Blue 18	0-255	255
-	72	Lime 18	0-255	255

## RDM FUNCTIONS / REMOTE SETUP

RDM means “Remote Device Management” (control the unit from a distance). This projector works with a brief set of RDM-functions which means that it can setup a bi-directional communication with an RDM-compatible DMX-controller. Some of these functions are briefly explained below, others will be added in the future.

- The DMX-controller sends out a “discovery command”, all RDM devices respond and send their unique device ID.
- The DMX-controller asks each RDM device for some basic data so it knows which devices are connected. The projector will respond:
  - **Device name:** BTI-BEAMBAR18
  - **Manufacturer:** Briteq®
  - **Category:** LED Dimmer
  - **Firmware:** x.x.x.x (firmware version of the projector)
  - **DMX address:** xxx (current DMX start address of the projector)
  - **DMX footprint:** xx (number of DMX-channels used by the projector)
  - **Personality:** xx (current personality or DMX-working mode used by the projectors)
  - **Temperature:** xx°C (current LED temperature)
- The DMX-controller can send certain commands to each RDM device which allow remote setup of the units. Thanks to this the projectors can be setup remotely.

### The following functions can be managed remotely:

No longer need to take a ladder and set all units one by one!

- **DMX START ADDRESS:** The start address can be set remotely from 001 to xxx.
- **PERSONALITY:** The DMX working mode (DMX-chart) can be set remotely.
- **LABEL:** The fixture can be given a custom label for easy management

These 2 functions make it possible to prepare a complete DMX-patch of all projectors on the DMX-controller and send these data to all projectors at once. More functions will be added later.

## MAINTENANCE

- Make sure the area below the installation place is free from unwanted persons during servicing.
- Switch off the unit, unplug the mains cable and wait until the unit has been cooled down.

### During inspection the following points should be checked:

- All screws used for installing the device and any of its parts should be tightly fastened and may not be corroded.
- Housings, fixations and installations spots (ceiling, truss, suspensions) should be totally free from any deformation.
- When an optical lens is visibly damaged due to cracks or deep scratches, it must be replaced.
- The mains cables must be in impeccable condition and should be replaced immediately when even a small problem is detected.
- In order to protect the device from overheat the cooling fans (if any) and ventilation openings should be cleaned monthly.

- The cleaning of internal and external optical lenses and/or mirrors must be carried out periodically to optimize light output. Cleaning frequency depends on the environment in which the fixture operates: damp, smoky or particularly dirty surroundings can cause greater accumulation of dirt on the unit's optics.
  - Clean with a soft cloth using normal glass cleaning products.
  - Always dry the parts carefully.

**Attention:** We strongly recommend internal cleaning to be carried out by qualified technician!

## SPECIFICATIONS

This unit is radio-interference suppressed. This product meets the requirements of the current European and national guidelines. Conformity has been established and the relevant statements and documents have been deposited by the manufacturer.

<b>Power supply</b>	AC 100-240V, 50/60Hz
<b>Power consumption</b>	500 Watt max (all pixels @ 100%)
<b>Power factor (PF)</b>	0,90
<b>Power in/out linking capacity</b>	12A @ 240Vac * 26A @ 110Vac
<b>Power connections</b>	PowerCON TRUE1 compatible connector
<b>Protection rating</b>	IP65
<b>LEDs</b>	18pcs 25W RGBL
<b>Supported control signals:</b>	DMX512+RDM, Art-Net™, sACN
<b>DMX connections</b>	5pin XLR male + 5pin XLR female
<b>DMX channel modes</b>	5 modes: 11 → 96 channels
<b>Beam angle</b>	6°
<b>LED refresh rate</b>	1200Hz-4800Hz
<b>Enclosure temperature (T<sub>a</sub>: 40°C)</b>	Surface: 65°C max.
<b>Dimensions LxWxD (mm)</b>	1002x230x186 (see drawing)
<b>Weight (kg)</b>	10.8

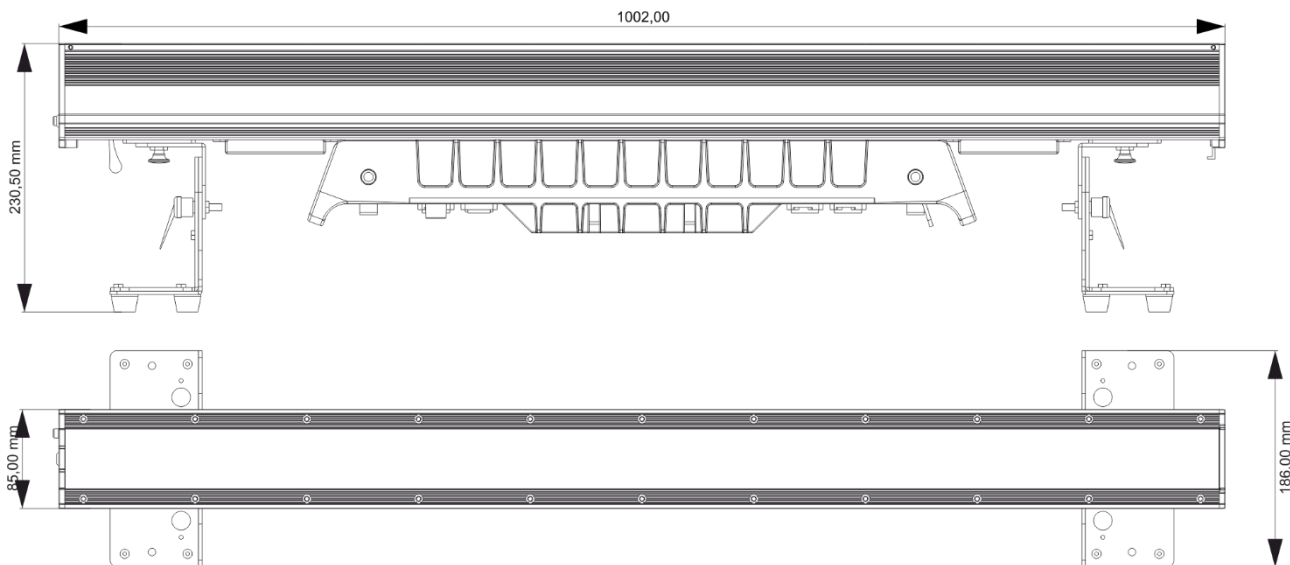

### LUX CHART

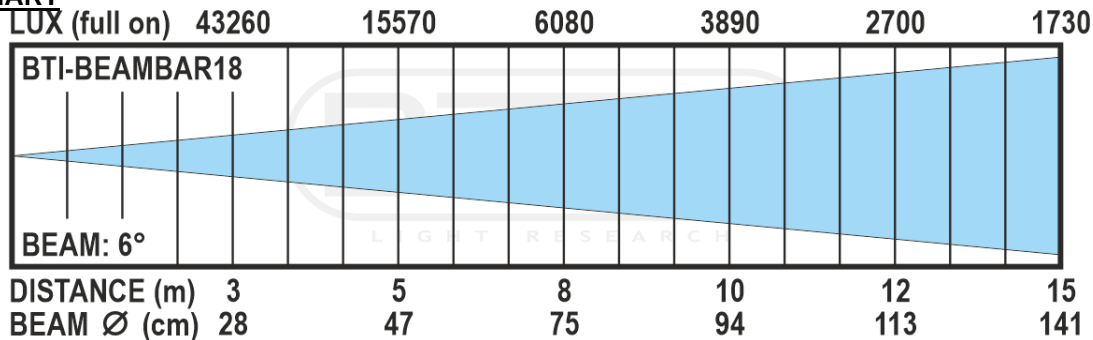

**COLOR VALUES PRESETS**

CCT presets	
8000K	R=255, G=232, B=230, L=255
7500K	R=255, G=227, B=167, L=155
6500K	R=255, G=191, B=134, L=155
6000K	R=255, G=145, B=147, L=255
5600K	R=255, G=122, B=127, L=255
5000K	R=255, G=080, B=096, L=255
4500K	R=255, G=040, B=070, L=255
4000K	R=255, G=011, B=045, L=255
3500K	R=255, G=000, B=018, L=219
3200K	R=255, G=000, B=011, L=164
3000K	R=255, G=000, B=008, L=128
2700K	R=255, G=000, B=006, L=090
2500K	R=255, G=000, B=005, L=071
2300K	R=255, G=000, B=003, L=051
2000K	R=255, G=000, B=001, L=028
1800K	R=255, G=017, B=000, L=013

Color presets	
Cyan	R=000, G=255, B=255, L=000
Yellow	R=255, G=255, B=000, L=000
Magenta	R=255, G=000, B=255, L=000
Medium Yellow	R=156, G=126, B=000, L=000
Straw Tint	R=152, G=115, B=009, L=000
Surprise Peach	R=198, G=114, B=009, L=000
Fire	R=255, G=056, B=000, L=000
Medium Amber	R=255, G=135, B=000, L=000
Gold Amber	R=255, G=100, B=000, L=000
Dark Amber	R=255, G=065, B=000, L=000
Sunrise Red	R=255, G=083, B=002, L=000
Light Pink	R=255, G=112, B=000, L=141
Medium Pink	R=255, G=087, B=000, L=107
Pink Carnation	R=255, G=107, B=000, L=130
Light Lavender	R=243, G=117, B=039, L=197
Sky Blue	R=000, G=255, B=135, L=000
Just Blue	R=000, G=194, B=130, L=000
Dark yellow green	R=041, G=219, B=000, L=000
Spring Yellow	R=245, G=202, B=000, L=000
Light Amber	R=237, G=163, B=000, L=000
Straw Tint	R=230, G=160, B=000, L=069
Deep Amber	R=255, G=166, B=000, L=000
Orange	R=255, G=122, B=000, L=000
Light Rose	R=255, G=141, B=031, L=000
Middle Rose	R=217, G=130, B=028, L=000
Dark Pink	R=255, G=109, B=033, L=000
Magenta	R=255, G=020, B=015, L=000
Peacock Blue	R=051, G=255, B=051, L=000
Steel Blue	R=206, G=255, B=056, L=000
Light Blue	R=074, G=255, B=082, L=000
Dark Blue	R=000, G=186, B=255, L=000
Leaf Green	R=206, G=255, B=000, L=000
Dark Green	R=084, G=255, B=013, L=000
Mauve	R=227, G=041, B=056, L=000
Deep Golden Amber	R=255, G=058, B=000, L=000
Pale Lavender	R=255, G=197, B=061, L=000
Primary Green	R=077, G=255, B=000, L=000
Bright Blue	R=000, G=255, B=087, L=000
Apricot	R=255, G=143, B=013, L=000
Pale Gold	R=253, G=171, B=026, L=000
Deep Orange	R=222, G=084, B=000, L=000
Flame Red	R=255, G=046, B=002, L=000



The information might be modified without prior notice  
You can download the latest version of this user manual on our website: [www.briteq-lighting.com](http://www.briteq-lighting.com)







## MAILING LIST

**EN: Subscribe today to our mailing list for the latest product news!**

**FR: Inscrivez-vous à notre liste de distribution si vous souhaitez suivre l'actualité de nos produits!**

**NL: Abonneer je vandaag nog op onze mailinglijst en ontvang ons laatste product nieuws!**

**DE: Abonnieren Sie unseren Newsletter und erhalten Sie aktuelle Produktinformationen!**

**ES: Suscríbete hoy a nuestra lista de correo para recibir las últimas noticias!**

**PT: Inscreva-se hoje na nossa mailing list para estar a par das últimas notícias!**

**[WWW.BRITEQ-LIGHTING.COM](http://WWW.BRITEQ-LIGHTING.COM)**

**Copyright © 2024 by BEGLEC NV**

't Hofveld 2C ~ B1702 Groot-Bijgaarden ~ Belgium

Reproduction or publication of the content in any manner, without express permission of the publisher, is prohibited.