

BTI-THEATRE 6C20

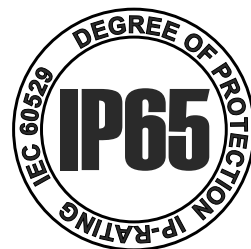

ENGLISH Operation Manual

Other languages can be downloaded from:
WWW.BRITEQ-LIGHTING.COM

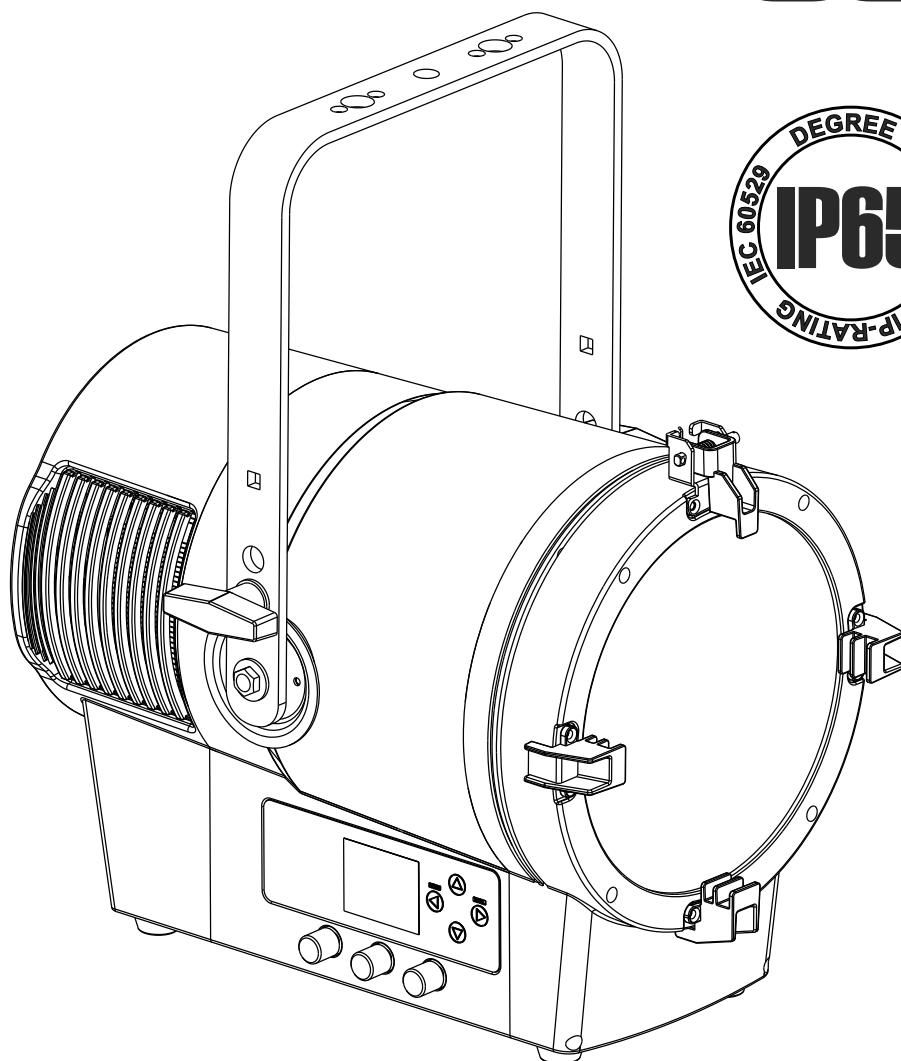

Version: 1.0





EN - DISPOSAL OF THE DEVICE

Dispose of the unit and used batteries in an environment friendly manner according to your country regulations.

FR - DÉCLASSER L'APPAREIL

Débarrassez-vous de l'appareil et des piles usagées de manière écologique conformément aux dispositions légales de votre pays.

NL - VERWIJDEREN VAN HET APPARAAT

Verwijder het toestel en de gebruikte batterijen op een milieuvriendelijke manier conform de in uw land geldende voorschriften.

DU - ENTSORGUNG DES GERÄTS

Entsorgen Sie das Gerät und die Batterien auf umweltfreundliche Art und Weise gemäß den Vorschriften Ihres Landes.

ES - DESHACERSE DEL APARATO

Reciclar el aparato y pilas usadas de forma ecologica conforme a las disposiciones legales de su país.

PT - COMO DESFAZER-SE DA UNIDADE

Tente reciclar a unidade e as pilhas usadas respeitando o ambiente e em conformidade com as normas vigentes no seu país.

OPERATION MANUAL

Thank you for buying this Briteq® product. To take full advantage of all possibilities and for your own safety, please read these operating instructions very carefully before you start using this unit.

FEATURES

- This LED fresnel spotlight features powerful 400W multi-color LED technology.
- IP65 housing with internal motorized zoom: no telescopic for enhanced robustness and higher reliability!
- It is a perfect replacement for energy consuming 2kW halogen lamps in theaters!
- The 6-color RGBALC LED cluster (red, green, blue, amber, lime, cyan) guarantees:
 - Perfect white presets between 1800K and 10000K with high CRI >90Ra
 - Rich color selection with the same color presets as in the BT-PROFILE 6C20 & BT-THEATRE HD
 - Very realistic amber drift (dim-to-warm) emulation of traditional halogen lamps
- Color calibration system makes color differences between different batches a thing of the past
- Very quiet operation with low-noise cooling fan and different fan presets (auto, studio, power)
- Can be used in standalone mode, without any DMX control
- DMX-controlled: 8 different channel modes for maximum flexibility
- **Built-in wireless DMX-receiver** (W-DMX / CRMX compatible).
- RDM functionality for easy remote installation
- Flicker-free TV shooting thanks to adjustable high speed LED refresh rate
- Fast and slow dimmer response
- LCD display for easy navigation through the setup menu
- Lock function to prevent unwanted altering of the settings
- 5-pin DMX in/outputs – Compatible with BT-XLR5TO3 COMBIKIT
- PowerCON TRUE1 compatible in/outputs for easy daisy-chaining.

BEFORE USE

- Before you start using this unit, please check if there's no transportation damage. Should there be any, do not use the device and consult your dealer first.
- **Important:** This device left our factory in perfect condition and well packaged. It is absolutely necessary for the user to strictly follow the safety instructions and warnings in this user manual. Any damage caused by mishandling is not subject to warranty. The dealer will not accept responsibility for any resulting defects or problems caused by disregarding this user manual.
- Keep this booklet in a safe place for future consultation. If you sell the fixture, be sure to add this user manual.

Check the contents:

Check that the carton contains the following items:

- BTI-THEATRE 6C20
- Power cable
- Safety cable
- English operating instructions, other languages can be downloaded from our website.

SAFETY INSTRUCTIONS:



CAUTION
RISK OF ELECTRIC SHOCK
DO NOT OPEN



CAUTION: To reduce the risk of electric shock, do not remove the top cover. No user-serviceable parts inside. Refer servicing to qualified service personnel only.



The lightning flash with arrowhead symbol within the equilateral triangle is intended to alert the user to the presence of un-insulated "dangerous voltage" within the product's enclosure that may be of sufficient magnitude to constitute a risk of electric shock.



The exclamation point within the equilateral triangle is intended to alert the user to the presence of important operation and maintenance (servicing) instructions in the literature accompanying this appliance.



This symbol means: Read instructions



This symbol determines: the minimum distance from lighted objects. The minimum distance between light-output and the illuminated surface must be more than 0.5 meter

RISK GROUP 2
CAUTION:
Do not stare at operating lamp

CAUTION: Do not stare at operating lamp.
May be harmful to the eyes.

- To protect the environment, please try to recycle the packing material as much as possible.
- To avoid condensation forming inside, allow the unit to adapt to the surrounding temperatures when bringing it into a warm room after transport. Condensation sometimes prevents the unit from working at full performance or may even cause damage.
- Don't place metal objects or spill liquid inside the unit. Electric shock or malfunction may result. If a foreign object enters the unit, immediately disconnect the mains power.
- Locate the fixture in a well-ventilated spot, away from any flammable materials and/or liquids. The fixture must be fixed at least 50cm from surrounding walls.
- Don't cover any ventilation openings as this may result in overheating.
- Prevent use in dusty environments and clean the unit regularly.
- Keep the unit away from children.
- Inexperienced persons should not operate this device.
- Maximum ambient temperature is 40°C. Don't use this unit at higher ambient temperatures.
- Make sure the area below the installation of the fixture is free from unwanted persons during rigging, de-rigging and servicing.
- Allow the device about 10 minutes to cool down before to start servicing.
- Always unplug the unit when it is not used for a longer time or before starting servicing.
- The electrical installation should be carried out by qualified personnel only, according to the regulations for electrical and mechanical safety in your country.
- Check that the available voltage is not higher than the one stated on the unit.
- The power cord should always be in perfect condition. Switch the unit immediately off when the power cord is squashed or damaged. It must be replaced by the manufacturer, its service agent or similarly qualified persons in order to avoid a hazard.
- Never let the power cord come into contact with other cables!
- This fixture must be grounded in order to comply with electrical safety regulations.
- Don't connect the unit to any dimmer pack.
- Always use an appropriate and certified safety cable when installing the unit.
- In order to prevent electric shock, do not open the cover. Apart from the mains fuse there are no user serviceable parts inside.
- **Never** repair a fuse or bypass the fuse holder. **Always** replace a damaged fuse with a fuse of the same type and electrical specifications!
- In the event of serious operating problems, stop using the fixture and contact your dealer immediately.
- The housing and the lenses must be replaced if they are visibly damaged.
- Please use the original packaging when the device is to be transported.
- Due to safety reasons it is prohibited to make unauthorized modifications to the unit.

Important: Never look directly into the light source! Don't use the effect in the presence of persons suffering from epilepsy.

DESCRIPTION:

REAR PANEL:

1. Seetronic IP65 power input/output
2. Fuse holder (20x5mm, T10A / 250V)
3. 3 and 5-pin XLR input/output
4. USB-C connector for firmware updates

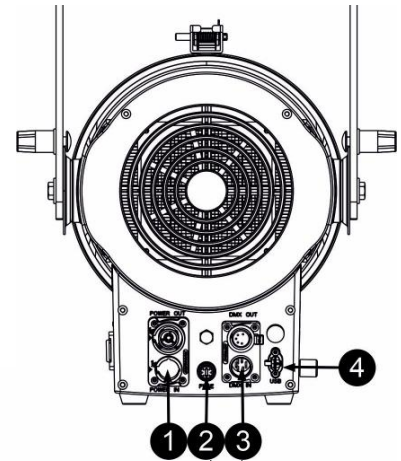

FRONT PANEL:

5. **Manual control encoders:** Used to manually adjust the dimmer, color and/or zoom
6. **Display:** turns black after a while, press the MENU button for 5s or one of the encoders to wake up again.
7. **MENU button:** press to go 1 level up in the menu tree.
Note: when the display is locked → press +/- 5 seconds to unlock the display.
▲/▼ buttons: used to browse the menu and to increase/decrease values.
8. **4-pin XLR battery input:** Accepts 24-36V

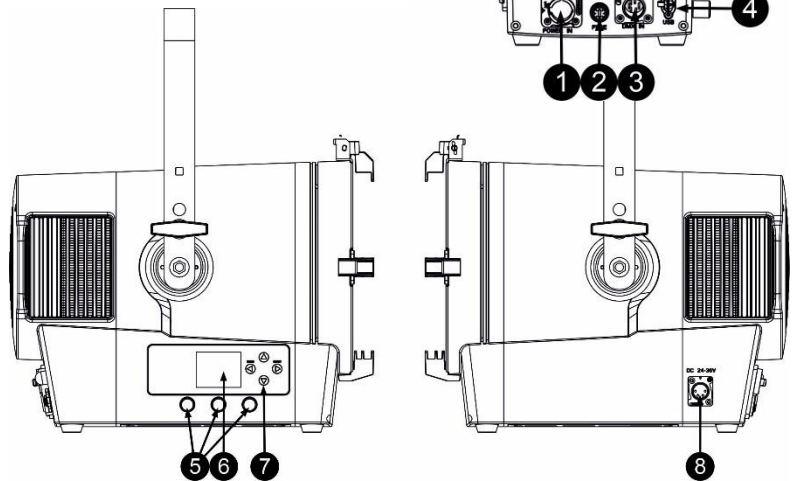

OVERHEAD RIGGING

- **Important:** The installation must be carried out by qualified service personnel only. Improper installation can result in serious injuries and/or damage to property. Overhead rigging requires extensive experience! Working load limits should be respected, certified installation materials should be used, the installed device should be inspected regularly for safety.
- Make sure the area below the installation place is free from unwanted persons during rigging, de-rigging and servicing.
- Locate the fixture in a well ventilated spot, far away from any flammable materials and/or liquids. The fixture must be fixed **at least 50cm** from surrounding walls.
- The device should be installed out of reach of people and outside areas where persons may walk by or be seated.
- Before rigging make sure that the installation area can hold a minimum point load of 10 times the device's weight.
- Always use a certified safety cable that can hold 12 times the weight of the device when installing the unit. This secondary safety attachment should be installed in such a way that whichever part of the installation can drop no more than 20cm, if the main attachment should fail.
- The device should be well attached; a free-swing mounting is dangerous and must not be considered!
- Don't cover any ventilation openings as this may result in overheating.
- The operator has to make sure that the safety-related and machine-technical installations are approved by an expert before using them for the first time. The installations should be inspected every year by a skilled professional to be sure that safety is still optimal.

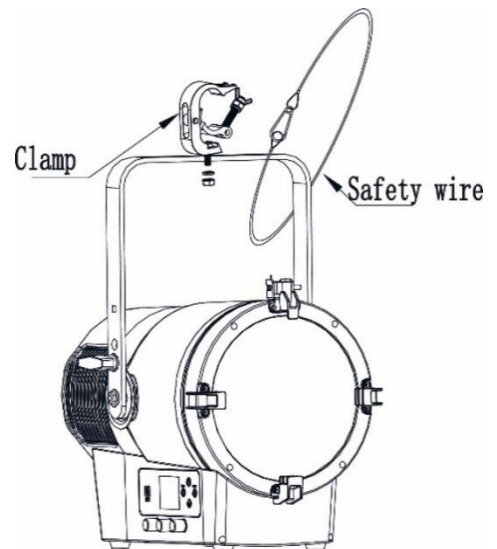

SETUP MENU / HOW TO SETUP

With the setup menu you can fully configure the projector. All settings are preserved when the unit is disconnected from the mains.

- [MENU] button: press to enter / leave the setup menu.
- ▶ [ENTER] button: press to select / confirm or store the current menu option or value.
- ▲/▼ [UP/DOWN] button: press to navigate the setup menu or change a value.

All passwords of this product are <UP>, <DOWN>, <UP>, <DOWN>, <ENTER>

Level 0	Level 1	Level 2	Default value	
knob mode	D+Z+CCT			
	D+Z+Col			
	HSI			
	D+CCT+Gr			
Static	Dimmer			
	Red			
	...			
	Strobe			
	Zoom			
Address	001-xxx		001	
Runmode	DMX512		DMX512	
	Slave			
Personality	HSIC		TOUR	
	SSP			
	TOUR			
	TR16			
	CMY			
Auto program	Auto. 1			
	...			
	PR. 2			
Edit	Program 1	Dimmer		
		Red		
		...		
		Zoom		
		Time (*0,1s)		
		Fade		
	Program 2			
Clean edit 1	No/Yes			
Clean edit 2	No/Yes			
Setting	Reset	Factory reset		
	Upload			
	Dimmer speed	Halogen		LED
		LED		
	Dimmer curve	Linear		Square law
		Square law		
		Inv. Square law		
		S-Curve		
	Tungsten fade	On/Off		Off
	DMX error	Freeze		Freeze
		Blackout		
Static				
PWM rate	1200Hz		2400Hz	
	2400Hz			
	4000Hz			
	6000Hz			
	25000Hz			
	40000Hz			

	Fan speed	Studio	Auto
		Power	
		Auto	
	DISP key	On/Off	On
	DISP time	On	30s
		30s	
		1min	
		2min	
	Color cali	Off	Factory
		User	
Factory			
Motor reset	No/Yes		
Battery limit	Full power	Full power	
	300W		
	200W		
	100W		
WDMX Pairing	Yes		
	Reset		
Signal	only XLRDMX	Only XLRDMX	
	XLRDMX first		
	only WDMX		
	WDMX first		
	WDMX to XLRDMX		
Info	Fixture hours		
	Temperature		
	Version		
	RDM UID		
	System error		
Update software			

ELECTRICAL INSTALLATION + ADDRESSING

⚠ Important: The electrical installation should be carried out by qualified personnel only, according to the regulations for electrical and mechanical safety in your country.

Electrical installation for two or more units in DMX-mode:

- The DMX protocol is a commonly used signal for controlling intelligent lighting equipment. You must connect your DMX controller and all connected devices in series using a good quality balanced cable.
- To prevent strange behavior of the lighting effects due to interference, it is recommended to use a 120-ohm terminating resistor at the end of the chain. This is usually an XLR connector with a 120-ohm resistor between pin 2 and pin 3.
- Make sure that all devices are connected to the mains.
- Each lighting effect in the chain must have its own start address so that it knows which commands from the controller to decode. In the next section, you will learn how to set the DMX addresses.

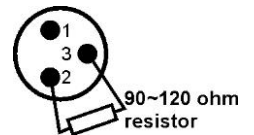

USE IN STAND-ALONE (STATIC) MODE

- In the setup menu: select [RUN MODE] and choose the option [STATIC]
- Now you can set the desired output manually:
 - **Set any desired color:** combine the settings of the different separate colors
 - **Set one of the color presets:** choose [COL PRESETS] and select one of the 48 presets
 - **Set one of the CCT presets:** choose [CCT PRESETS] and select one of the CCT-presets
- Choose the option [DIMMER] and set the desired light output.

Remark: if you don't use the preset options, both should be set to "NONE" to select any desired color.

RDM FUNCTIONS / REMOTE SETUP

RDM means “Remote Device Management”. This projector works with a brief set of RDM-functions which means that it can setup a bi-directional communication with an RDM-compatible DMX-controller. Some of these functions are briefly explained below, others will be added in the future.

- The DMX-controller sends out a “discovery command”, all RDM devices respond and send their unique device ID.
- The DMX-controller asks each RDM device for some basic data so it knows which devices are connected. The projector will respond:
 - **Device name:** BTI-THEATRE 6C20
 - **Manufacturer:** Briteq®
 - **Category:** LED Dimmer
 - **Firmware:** x.x.x.x (firmware version of the projector)
 - **DMX address:** xxx (current DMX start address of the projector)
 - **DMX footprint:** xx (number of DMX-channels used by the projector)
 - **Personality:** xx (current personality [or DMX-working mode] used by the projectors)
 - **Temperature:** xx°C Temperature of the LED engine
- The DMX-controller can send certain commands to each RDM device which allow remote setup of the units. Thanks to this the projector can be setup remotely.

The following functions can be managed remotely:

No more need to take a ladder and set all units one by one!

- **DMX START ADDRESS:** The start address can be set remotely from 001 to xxx.
- **PERSONALITY:** The DMX working mode (DMX-chart) can be set remotely.
- **PWM frequency:** The LED refresh rate can be remotely set
- **Dimmer curve:** The dimmer curve can be changed remotely

These 4 functions make it possible to prepare a complete DMX-patch of all projectors on the DMX-controller and send these data to all projectors at once. More functions will be added later.

DMX CHARTS

HSIC	CMY	SSP	Tour	TR16	Function	Value	
1	-	-	-	-	Intensity	0-255	
2	-	-	-	-	Hue	0-255	
3	-	-	-	-	Hue fine	0-255	
4	-	-	-	-	Saturation	0-255	
-	1	1	1	1	Dimmer	0-255	
-	-	-	2	2	Dimmer fine	0-255	
-	-	2	3	3	Red	0-255	
-	-	-	-	4	Red fine	0-255	
-	-	3	4	5	Green	0-255	
-	-	-	-	6	Green fine	0-255	
-	-	4	5	7	Blue	0-255	
-	-	-	-	8	Blue fine	0-255	
-	-	5	6	9	Amber	0-255	
-	-	-	-	10	Amber fine	0-255	
-	-	6	7	11	Lime	0-255	
-	-	-	-	12	Lime fine	0-255	
-	2	7	8	13	Cyan	0-255	
-	-	-	-	14	Cyan fine	0-255	
-	3	-	-	-	Magenta	0-255	
-	4	-	-	-	Yellow	0-255	
5	5	-	9	15	Color presets	0-10	Disabled
						11-255	Color presets

6	6	-	10	16	CCT	0-9	Disabled
						10	1800K
						25	2200K
						40	2700K
						55	3000K
						70	3200K
						85	4000K
						100	4500K
						115	5000K
						130	5600K
						145	6000K
						160	6500K
						175	7000K
						190	8000K
205	10000K						
255	10000K						
7	7	-	11	17	Tint correction	0-16	Disabled
						17-116	Magenta 99% <> 1%
						117-139	Neutral (no effect)
						140-239	Green 1% <> 99%
						240-255	Green 100%
8	8	8	12	18	Strobe	0-9	Open
						10-99	Strobe (0-25Hz)
						100-109	Open
						110-179	Lightning strobe
						18-189	Open
						190-255	Random strobe
9	9	9	13	19	Zoom	0-255	
10	10	10	14	20	Control	0-10	No function
						11-20	Tungsten fade On (0s delay)
						21-30	Tungsten fade off (0s delay)
						31-60	No function
						61-70	Studio
						71-80	Power
						81-90	Auto
						91-100	Dimmer off (3s delay)
						101-110	Dimmer Dim4 (3s delay)
						111-120	Dimmer curve: Linear
						121-130	Dimmer curve: Square law
						131-140	Dimmer curve: Inv. Square
						141-150	Dimmer curve: S-curve
						151-160	PWM: 1200Hz (3s delay)
						161-170	PWM: 2400Hz (3s delay)
						171-180	PWM: 4000Hz (3s delay)
						181-190	PWM: 6000Hz (3s delay)
191-200	PWM: 25000Hz (3s delay)						
201-210	All reset (3s delay)						
211-255	No function						

MAINTENANCE

- Make sure the area below the installation place is free from unwanted persons during servicing.
 - Switch off the unit, unplug the mains cable and wait until the unit has cooled down.
- During inspection the following points should be checked:**
- All screws used for installing the device and any of its parts should be tightly fastened and may not be corroded.
 - Housing, fixations, and installations spots (ceiling, truss, suspensions) should be totally free from any deformation.
 - When an optical lens is visibly damaged due to cracks or deep scratches, it must be replaced.
 - The mains cables must be in impeccable condition and should be replaced immediately when even a small problem is detected.
 - To keep the device from overheating, the cooling fans (if any) and ventilation openings should be cleaned monthly.
 - The interior of the device should be cleaned annually using a vacuum cleaner or air-jet.
 - The cleaning of internal and external optical lenses and/or mirrors must be carried out periodically to optimize light output. Cleaning frequency depends on the environment in which the fixture operates: damp, smoky or particularly dirty surroundings can cause greater accumulation of dirt on the unit's optics.
 - Clean with a soft cloth using conventional glass cleaning products.
 - Always dry the parts carefully.

Attention: We strongly recommend internal cleaning to be carried out by qualified personnel!

SPECIFICATIONS

ENGLISH

BRITEQ® hereby declares that the equipment described in this manual complies with RED Directive 2014/53/EU. The full text of the EU Declaration of Conformity, as well as the latest version of the manual and technical specifications, are available at the following internet address (under Manual and downloads): <https://briteq-lighting.com/bti-theatre-6c20>

NEDERLANDS

Hierbij verklaart BRITEQ® dat de apparatuur beschreven in deze handleiding voldoet aan de richtlijn RED 2014/53/EU. De volledige tekst van de EU-conformiteitsverklaring, alsook de laatste versie van de handleiding en technische specificaties zijn beschikbaar op het volgende internetadres (onder Handleiding en downloads): <https://briteq-lighting.com/nl/bti-theatre-6c20>

FRANCAIS

BRITEQ® déclare par la présente que l'équipement décrit dans ce manuel est conforme à la directive RED 2014/53/UE. Le texte complet de la déclaration de conformité UE, ainsi que la dernière version du manuel et les spécifications techniques sont disponibles à l'adresse Internet suivante (sous Manuel et téléchargements) : <https://briteq-lighting.com/fr/bti-theatre-6c20>

DEUTSCH

Hiermit erklärt BRITEQ®, dass die in dieser Anleitung beschriebene Ausrüstung der RED Richtlinie 2014/53/EU entspricht. Der vollständige Text der EU-Konformitätserklärung sowie die neuesten Versionen der Anleitung und der technischen Spezifikationen sind unter folgender Internetadresse verfügbar (unter Anleitung und Downloads): <https://briteq-lighting.com/de/bti-theatre-6c20>

Power Supply:	AC 230 V, 50Hz
Fuse:	250V 10A slow blow (20mm glass)
Power consumption (max):	430 Watt
Power connections:	PowerCON TRUE1 compatible connector, input / output
Power Linking capacity:	6A @ 240V
Carrier Frequency Range:	2402 – 2480 MHz (GFSK modulation)
RF transmission power:	none, only RX-mode (receiver mode)
Sound Control:	No
DMX connections:	5pin XLR male / female – Compatible with BT-XLR5TO3 COMBIKIT
DMX channels used:	10, 14 and 20 channels
Lamp:	RGBALC LED 400W
CRI:	>90
Operating Temperature:	0°C – 45°C
Size:	See drawing
Weight:	10.5 kg
IP-Rating:	IP65

DIMENSIONS:

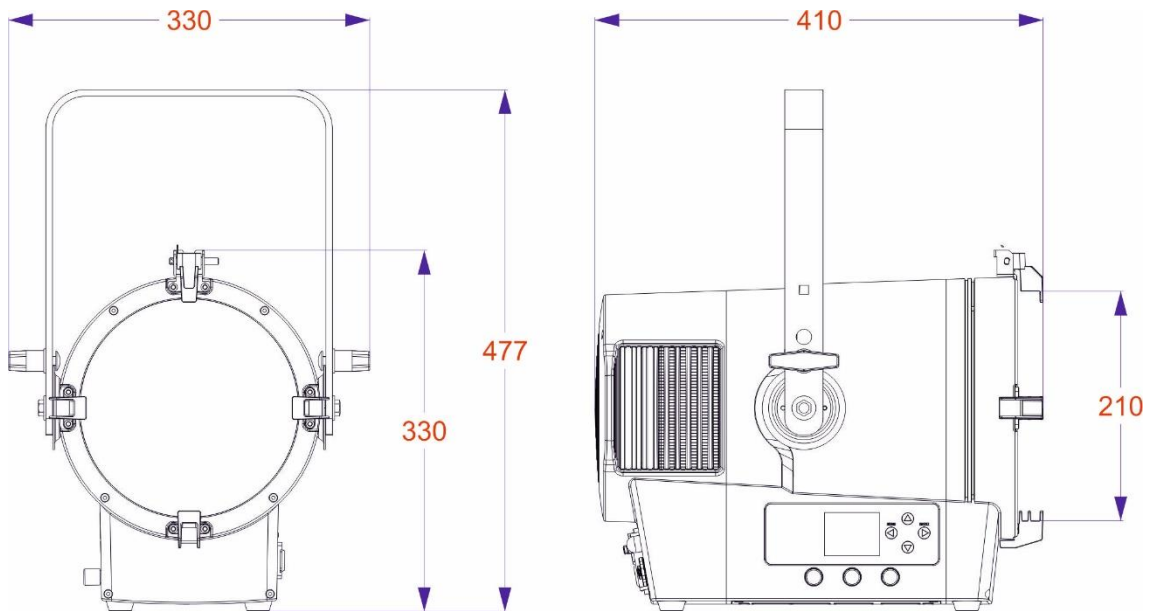

LUX CHART

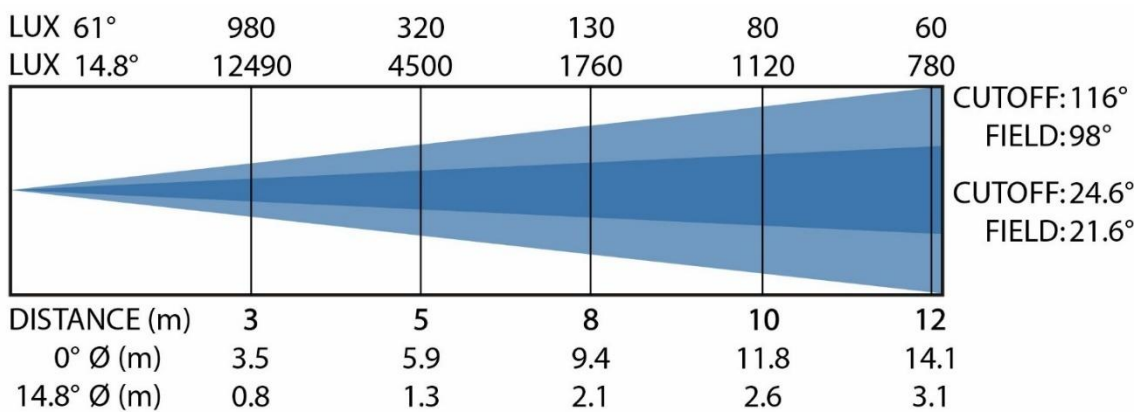

ANNEX 1 → COLOR PRESETS + LEE / ROSCO FILTER NAMES + CIE 1931 X/Y coordinates

PRESET	VALUE	COLOR NAME		X	Y
	000-010	NO FUNCTION			
COLOR 1	011-015	L176	Loving Amber	0.407	0.321
COLOR 2	016-020	R40	Light Salmon	0.499	0.321
COLOR 3	021-025	L24	Scarlet	0.561	0.296
COLOR 4	026-030	L164	Flame Red	0.659	0.302
COLOR 5	031-035	L747	Easy White	0.389	0.344
COLOR 6	036-040	R303	Warm Peach	0.448	0.353
COLOR 7	041-045	L08	Dark Salmon	0.498	0.347
COLOR 8	046-050	L25	Sunset Red	0.566	0.359
COLOR 9	051-055	L04	Medium Bastard Amber	0.370	0.335
COLOR 10	056-060	L237	C.I.D. (To Tungsten)	0.430	0.365
COLOR 11	061-065	R321	Soft Golden Amber	0.477	0.406
COLOR 12	066-070	L652	Urban Sodium	0.535	0.399
COLOR 13	071-075	L212	L.C.T. Yellow (Y1)	0.340	0.363
COLOR 14	076-080	L765	LEE Yellow	0.389	0.412
COLOR 15	081-085	L513	Ice and a Slice	0.380	0.447
COLOR 16	086-090	L100	Spring Yellow	0.410	0.502
COLOR 17	091-095	L244	LEE Plus Green	0.324	0.388
COLOR 18	096-100	R4430	Cal Color 30 Green	0.318	0.440
COLOR 19	101-105	L122	Fern Green	0.234	0.543
COLOR 20	106-110	L90	Dark Yellow Green	0.184	0.641
COLOR 21	111-115	L243	LEE Fluorescent 3600K	0.286	0.370
COLOR 22	116-120	R92	Turquoise	0.235	0.360
COLOR 23	121-125	R94	Kelly Green	0.185	0.459
COLOR 24	126-130	L327	Forest Green	0.162	0.496
COLOR 25	131-135	L191	Cosmetic Aqua Blue	0.300	0.318
COLOR 26	136-140	L728	Steel Green	0.256	0.302
COLOR 27	141-145	L117	Steel Blue	0.223	0.278
COLOR 28	146-150	L354	Special Steel Blue	0.173	0.265
COLOR 29	151-155	L53	Paler Lavender	0.284	0.284
COLOR 30	156-160	L501	New Color Blue	0.246	0.249
COLOR 31	161-165	L174	Dark Steel Blue	0.204	0.205
COLOR 32	166-170	L165	Daylight Blue	0.159	0.158
COLOR 33	171-175	L136	Pale Lavender	0.288	0.254
COLOR 34	176-180	L194	Surprise Pink	0.240	0.183
COLOR 35	181-185	L142	Pale Violet	0.209	0.148
COLOR 36	186-190	L700	Perfect Lavender	0.177	0.070
COLOR 37	191-195	L35	Light Pink	0.335	0.289
COLOR 38	196-200	L794	Pretty 'n Pink	0.335	0.251
COLOR 39	201-205	L328	Follies Pink	0.335	0.180
COLOR 40	206-210	L795	Magical Magenta	0.327	0.138
COLOR 41	211-215	L154	Pale Rose	0.350	0.318
COLOR 42	216-220	L127	Smokey Pink	0.397	0.265
COLOR 43	221-225	L192	Flesh Pink	0.410	0.237
COLOR 44	226-230	L332	Special Rose Pink	0.465	0.193
COLOR 45	231-235	L790	Moroccan Pink	0.378	0.324
COLOR 46	236-240	L157	Pink	0.457	0.272
COLOR 47	241-245	R332	Cherry Rose	0.489	0.295
COLOR 48	246-250	L128	Cool LED Bright Pink	0.570	0.263
	251-255	NO FUNCTION			

The information might be modified without prior notice
 You can download the latest version of this user manual on our website: www.briteq-lighting.com



MAILING LIST

EN: Subscribe today to our mailing list for the latest product news!

FR: Inscrivez-vous à notre liste de distribution si vous souhaitez suivre l'actualité de nos produits!

NL: Abonneer je vandaag nog op onze mailinglijst en ontvang ons laatste product nieuws!

DE: Abonnieren Sie unseren Newsletter und erhalten Sie aktuelle Produktinformationen!

ES: Suscríbete hoy a nuestra lista de correo para recibir las últimas noticias!

PT: Inscreva-se hoje na nossa mailing list para estar a par das últimas notícias!

WWW.BRITEQ-LIGHTING.COM

Copyright © 2025 by BEGLEC NV

't Hofveld 2C ~ B1702 Groot-Bijgaarden ~ Belgium

Reproduction or publication of the content in any manner, without express permission of the publisher, is prohibited.