

ALIEN



ENGLISH Operation Manual

Other languages can be downloaded from:
WWW.JB-SYSTEMS.EU



Version: 1.0

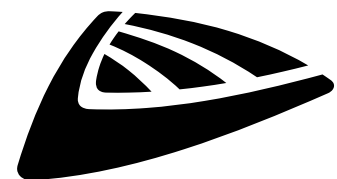

JB SYSTEMS



EN - DISPOSAL OF THE DEVICE

Dispose of the unit and used batteries in an environment friendly manner according to your country regulations.

FR - DÉCLASSER L'APPAREIL

Débarrassez-vous de l'appareil et des piles usagées de manière écologique Conformément aux dispositions légales de votre pays.

NL - VERWIJDEREN VAN HET APPARAAT

Verwijder het toestel en de gebruikte batterijen op een milieuvriendelijke manier conform de in uw land geldende voorschriften.

DU - ENTSORGUNG DES GERÄTS

Entsorgen Sie das Gerät und die Batterien auf umweltfreundliche Art und Weise gemäß den Vorschriften Ihres Landes.

ES - DESHACERSE DEL APARATO

Reciclar el aparato y pilas usadas de forma ecologica conforme a las disposiciones legales de su país.

PT - COMO DESFAZER-SE DA UNIDADE

Tente reciclar a unidade e as pilhas usadas respeitando o ambiente e em conformidade com as normas vigentes no seu país.

OPERATION MANUAL

Thank you for buying this JB Systems® product. To take full advantage of all possibilities and for your own safety, please read these operating instructions very carefully before you start using this unit.

FEATURES

- 5 different effects in one single unit !
 - 3 individual Led Projectors for colored beams + UV/Blacklight effect (9x8W Red-Green-Blue-UV Leds)
 - LED effect: 84x0.75W Leds (Red-Green-Blue-Amber) for dynamic multibeam patterns
 - Led Strobe: 12x 0.5Watt White Leds
 - Laser: red (100mW) and green (30mW) laser patterns
- Use the unit in any way you like it !
 - Standalone: sound activated (internal mic) or automatic shows. IR remote controller included.
 - Master/slave function for wonderful synchronized shows when several units are used.
 - DMX-control: via 3, 9, 11 or 28 Channels.
- 3-digit LED display for easy menu navigation
- IEC mains input + output for easy linking (check out our combi cables)
- Key activated on/off switch and emergency switch (interlock) input for additional laser safety
- Complies to EN/IEC 60825-1 for Laser Safety

BEFORE USE

- Before you start using this unit, please check if there's no transportation damage. Should there be any, do not use the device and consult your dealer first.
- **Important:** This device left our factory in perfect condition and well packaged. It is absolutely necessary for the user to strictly follow the safety instructions and warnings in this user manual. Any damage caused by mishandling is not subject to warranty. The dealer will not accept responsibility for any resulting defects or problems caused by disregarding this user manual.
- Keep this booklet in a safe place for future consultation. If you sell the fixture, be sure to add this user manual.

Check the contents:

Check that the cardboard box contains the following items:

- ALIEN unit
- 2 keys (for key switch)
- Spare connector for emergency stop
- Mains cable
- IR Remote controller
- Operating instructions

SAFETY INSTRUCTIONS:



CAUTION
RISK OF ELECTRIC SHOCK
DO NOT OPEN



CAUTION: To reduce the risk of electric shock, do not remove the top cover. No user-serviceable parts inside. Refer servicing to qualified service personnel only.



The lightning flash with arrowhead symbol within the equilateral triangle is intended to alert the user or the presence of un-insulated "dangerous voltage" within the product's enclosure that may be of sufficient magnitude to constitute a risk of electric shock.



The exclamation point within the equilateral triangle is intended to alert the user to the presence of important operation and maintenance (servicing) instructions in the literature accompanying this appliance.



This symbol means: indoor use only.



This symbol means: Read instructions.



This symbol determines: the minimum distance from lighted objects. The minimum distance between light-output and the illuminated surface must be more than 1 meter.

- To protect the environment, please try to recycle the packing material as much as possible.
- A new light effect sometimes causes some unwanted smoke and/or smell. This is normal and disappears after some minutes.
- To prevent fire or shock hazard, do not expose this appliance to rain or moisture.
- To avoid condensation to be formed inside, allow the unit to adapt to the surrounding temperatures when bringing it into a warm room after transport. Condense sometimes prevents the unit from working at full performance or may even cause damages.
- This unit is for indoor use only.
- Don't place metal objects or spill liquid inside the unit. Electric shock or malfunction may result. If a foreign object enters the unit, immediately disconnect the mains power.
- Locate the fixture in a well ventilated spot, away from any flammable materials and/or liquids. The fixture must be fixed at least 50cm from surrounding walls.
- Don't cover any ventilation openings as this may result in overheating.
- Prevent use in dusty environments and clean the unit regularly.
- Keep the unit away from children.
- Inexperienced persons should not operate this device.
- The save ambient temperature is between 15° & 40°C. Don't use this unit at higher ambient temperatures.
- Make sure the area below the installation place is free from unwanted persons during rigging, de-rigging and servicing.
- Always unplug the unit when it is not used for a longer time or before replacing the bulb or start servicing.
- The electrical installation should be carried out by qualified personal only, according to the regulations for electrical and mechanical safety in your country.
- Check that the available voltage is not higher than the one stated on the rear panel of the unit.
- The power cord should always be in perfect condition. Switch the unit immediately off when the power cord is squashed or damaged. It must be replaced by the manufacturer, its service agent or similarly qualified persons in order to avoid a hazard.
- Never let the power-cord come into contact with other cables!
- This fixture must be earthed to in order comply with safety regulations.
- Don't connect the unit to any dimmer pack.
- Always use an appropriate and certified safety cable when installing the unit.
- In order to prevent electric shock, do not open the cover. Apart from the lamp and mains fuse there are no user serviceable parts inside.
- **Never** repair a fuse or bypass the fuse holder. **Always** replace a damaged fuse with a fuse of the same type and electrical specifications!
- In the event of serious operating problems, stop using the fixture and contact your dealer immediately.
- The housing and the lenses must be replaced if they are visibly damaged.
- Please use the original packing when the device is to be transported.
- Due to safety reasons it is prohibited to make unauthorized modifications to the unit.

Important: Never look directly into the light source! Don't use the effect in the presence of persons suffering from epilepsy.

LASER SAFETY INSTRUCTIONS:

- According to the EN/IEC 60825-1 regulations, this laser falls under the classification 3R. Direct eye exposure can be dangerous.



DANGER: LASER RADIATION !

Avoid direct eye exposure! Laser radiation can cause eye damage and/or skin damage. All protective measures for a safe operation of this laser must be applied.



- This product is a so-called show laser, emitting radiation with a wavelength spectrum between 400 and 700 nm and producing lighting effects for shows.
- Laser Light is different from any other light source with which you may be familiar. The light from this product can potentially cause eye injury if not set up and used properly. Laser light is thousands of times more concentrated than light from any other kind of light source. This concentration of light power can cause instant eye injuries, primarily by burning the retina (the light sensitive portion at the back of the eye). Even if you cannot feel "heat" from a laser beam, it can still potentially injure or blind you or your audience.
- Even very small amounts of laser light are potentially hazardous even at long distances.
- Never look into the laser aperture or laser beams
- Never direct the laser beam to people or animals and never leave this device running unattended.
- This laser may only be used for shows. The operation of a class 3R show laser is only allowed if the operation is controlled by a skilled and well-trained operator.
- Depending on the classification, operating a laser product can produce laser radiation that may cause permanent eye damage and/or skin damage. The legal instructions for using a laser product vary from country to country. The user must always inform himself on the legal instructions valid in his country and apply them to his situation.
- The parent document and cornerstone of laser safety standards ANSI Z136.1 provides guidance for the safe use of lasers and laser systems by defining control measures for each of the four laser classes. This valuable document can be obtained from www.laserinstitute.org

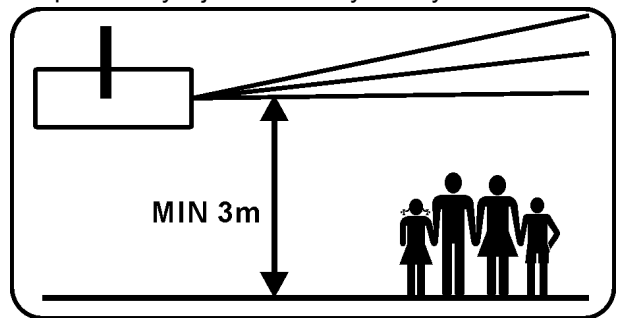

Please note that **JB SYSTEMS** cannot be made liable for damages caused by incorrect installations and unskilled operation!

DESCRIPTION:

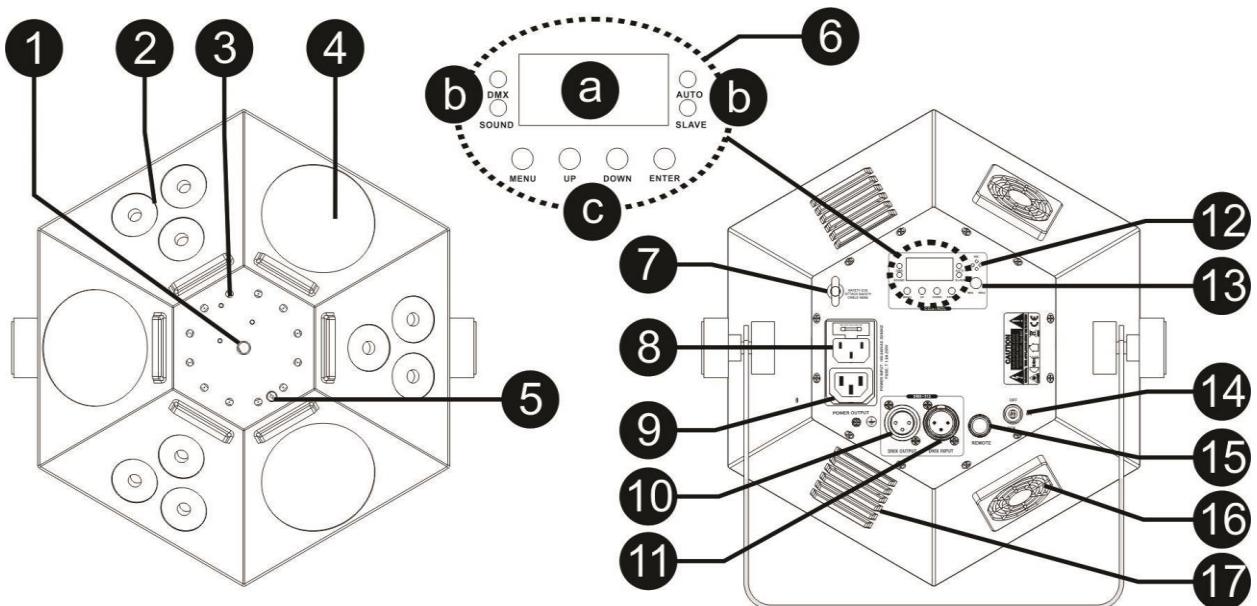

1. **LASER OUTPUT:** This is where the laser beams exit the enclosure, make sure to NEVER look inside the unit through this opening while the laser effect is switched on!
2. **WASH PROJECTOR LENSES:** output of the colored led projector for colored beams + UV effect. Don't expose to direct sunlight !
3. **STROBE EFFECT LENSES:** White SMD LEDs for the strobe effect!
4. **LED EFFECT LENSES:** output of the colored led effect. Don't expose to direct sunlight !
5. **IR RECEIVER:** when you use the IR remote controller, you should point the remote controller to this spot
6. **CONTROL PANEL:**

- a. **DISPLAY:** shows the various menus and the selected functions.
- b. **LEDS:**

DMX	On	DMX input present
AUTO	On	Master mode
SLAVE	On	Slave mode
SOUND	Flashing	Sound activation

- c. **BUTTONS:**

MENU	To browse the different menu options
UP	To go forward in the selected functions or to increase a value
DOWN	To go backward in the selected functions or to decrease a value
ENTER	To confirm the selected functions

7. **SAFETY EYEBOLT:** used to attach a safety cable when the unit is rigged (see paragraph "overhead rigging")
8. **MAINS INPUT:** with IEC socket and integrated fuse holder; connect the supplied mains cable here.
9. **MAINS OUTPUT:** you can use our "combi cables" and this IEC output to easily daisy-chain the next unit
10. **DMX OUTPUT:** 3pin female XLR-connector used to connect the LASER with the next unit in the DMX chain.
11. **DMX INPUT:** 3pin male XLR-connector used to connect universal DMX-cables. This input receives instructions from a DMX-controller.
12. **INTERNAL MICROPHONE:** The built-in microphone is used to synchronize the show to the beat of the music.
13. **SENSITIVITY KNOB:** The unit works to rhythm of the beat when used in standalone or master/slave mode. With this knob you can set the input sensitivity of the build-in microphone.
14. **ON/OFF KEY ACTIVATED SWITCH:** used to switch the unit on/off. Use the keys to make sure only a skilled operator is able to switch the laser on.
15. **INTERLOCK input:** used to connect the optional emergency stop switch (see picture). When you push this switch the laser beam will disappear immediately.



IMPORTANT! For your own safety we strongly recommend to connect this optional switch! THERE WILL BE NO LASER OUTPUT WHEN THE INTERLOCK INPUT IS NOT USED! Temporary solution: install the spare connector on the laser. (see picture)



16. **FAN:** assures the cooling of the unit. Do not cover!
17. **VENTILATION OPENING:** used for the cooling of the unit. Do not cover the opening !

OVERHEAD RIGGING

- **Important:** The installation must be carried out by qualified service personal only. Improper installation can result in serious injuries and/or damage to property. Overhead rigging requires extensive experience! Working load limits should be respected, certified installation materials should be used, the installed device should be inspected regularly for safety.
- Make sure the area below the installation place is free from unwanted persons during rigging, de-rigging and servicing.
- Locate the fixture in a well ventilated spot, far away from any flammable materials and/or liquids. The fixture must be fixed **at least 50cm** from surrounding walls.

- The device should be installed out of reach of people and outside areas where persons may walk by or be seated.
- Before rigging make sure that the installation area can hold a minimum point load of 10times the device's weight.
- Always use a certified safety cable that can hold 12 times the weight of the device when installing the unit. This secondary safety attachment should be installed in a way that no part of the installation can drop more than 20cm if the main attachment fails.
- The device should be well fixed; a free-swinging mounting is dangerous and may not be considered!
- Don't cover any ventilation openings as this may result in overheating.
- The operator has to make sure that the safety-relating and machine-technical installations are approved by an expert before using them for the first time. The installations should be inspected every year by a skilled person to be sure that safety is still optimal.



CAUTION EYE DAMAGE: Always position the laser in a way that prevents the audience from looking directly into the laser beams. The installation should assure that the beam will not strike the audience.

HOW TO SET UP AND CONTROL THE UNIT

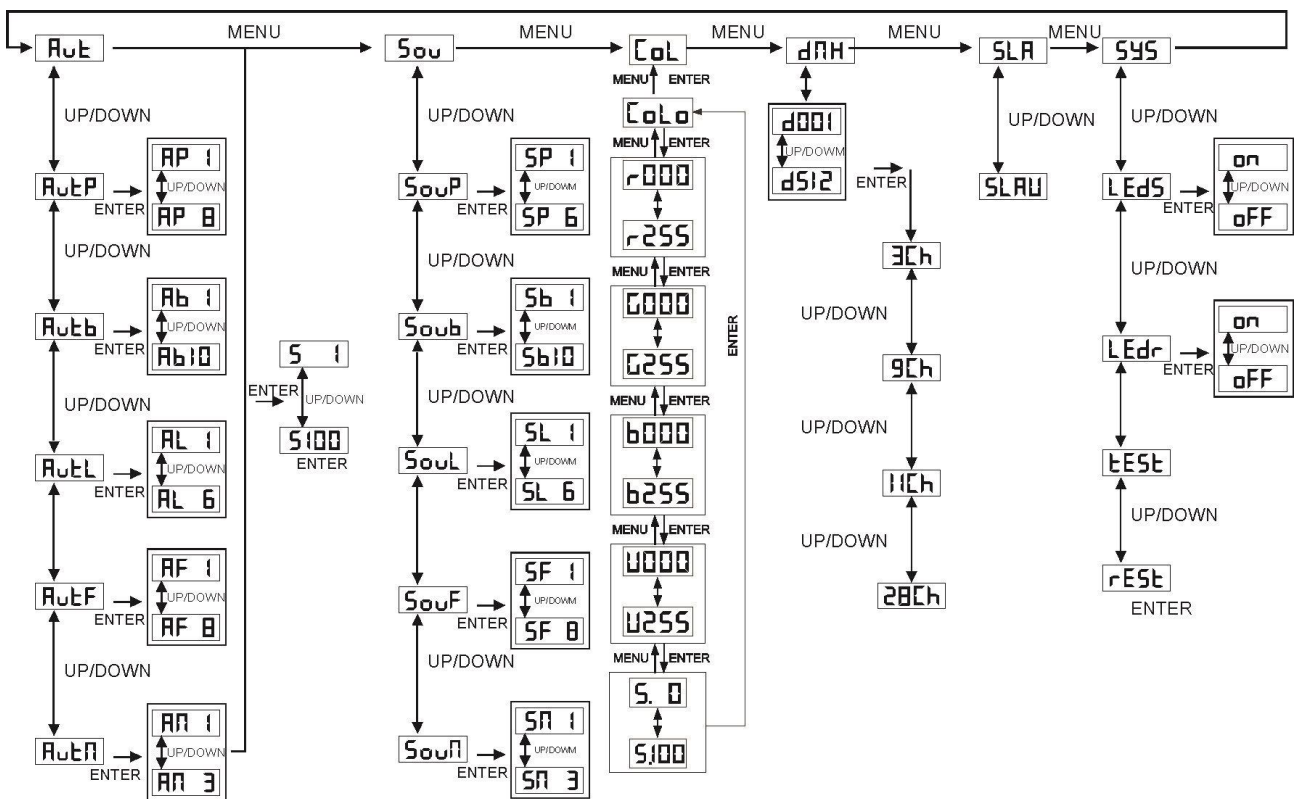

You can operate the unit in 4 ways:

1) MUSIC CONTROLLED MODE:

The unit runs a preprogrammed sequence to the rhythm of the music. Select this mode when only 1 unit is used (standalone) or when the unit is placed as the first (master) unit in a chain with several units.

- Press the [MENU] button until the display shows: [Sou]
- Now use the [UP] or [DOWN] to browse the different sound modes.
- Press the [ENTER] button to select the desired sound mode:
 - [SouP] = Wash projector effects [SP 1] to [SP 6]
 - [Soub] = Led Beam effects [Sb 1] to [Sb10]
 - [SouL] = Laser effects [SL 1] to [SL 3]
 - [SouF] = White Flash effects [SF 1] to [SF10]
 - [SouM] = Mixed effect [SM 1] to [SM 8]

- With the [UP] & [DOWN] buttons, you can choose different programs for the selected sound mode. (see above)
- Press the [ENTER] button to confirm your choice.
- Put on some music and set the sensitivity of the microphone by using the sensitivity knob (7) so that the effect reacts perfectly to the sound level of your music.

You can connect several units together: just put the first unit of the chain in one of the sound activated effect modes and all other units in “Slave mode” (display shows “SLA”) to make them all work in perfect sync!

Note: When no music is detected, the output of the unit will be shut off (blackout).

2) FULL AUTOMATIC MODE:

The unit automatically runs a preprogrammed sequence. Select this mode when only 1 unit is used (standalone) or when the unit is placed as the first (master) unit in a chain with several units.

- Press the [MENU] button until the display shows [Aut]
- Now use the [UP] or [DOWN] to browse the different automatic modes.
- Press the [ENTER] button to select the desired automatic mode:
 - [AutP] = Wash projector effects [AP 1] to [AP 8]
 - [Autb] = Led Beam effects [Ab 1] to [Ab10]
 - [AutL] = Laser effects [AL 1] to [AL 6]
 - [AutF] = White Flash effects [AF 1] to [AF 8]
 - [AutM] = Mixed effect [AM 1] to [AM 8]
- With the [UP] & [DOWN] buttons, you can choose different programs for the selected sound mode. (see above)
- Press the [ENTER] button to confirm your choice.
- Now use the [UP] or [DOWN] buttons to select the speed:
 - S 1 = Fastest speed
 - S 100 = Slowest speed
- Press the [ENTER] button to confirm your choice.

You can connect several units together: just put the first unit of the chain in one of the automatic effect modes and all other units in “Slave mode” (display shows “SLA”) to make them all work in perfect sync!

3) SLAVE MODE:

The unit follows the instructions given by the first unit (master) in the chain. Like this you can obtain nice synchronized shows.

- Connect the DMX input of the unit to the DMX output of the previous unit in the chain.
- Press the FUNC-button until the display shows [SLA]
- Press the ENTER-button to confirm your choice.

You can connect several units together. Please put the first unit of the chain in “Music or automatic mode” and all other units in “Slave mode” to make them all work in perfect sync!

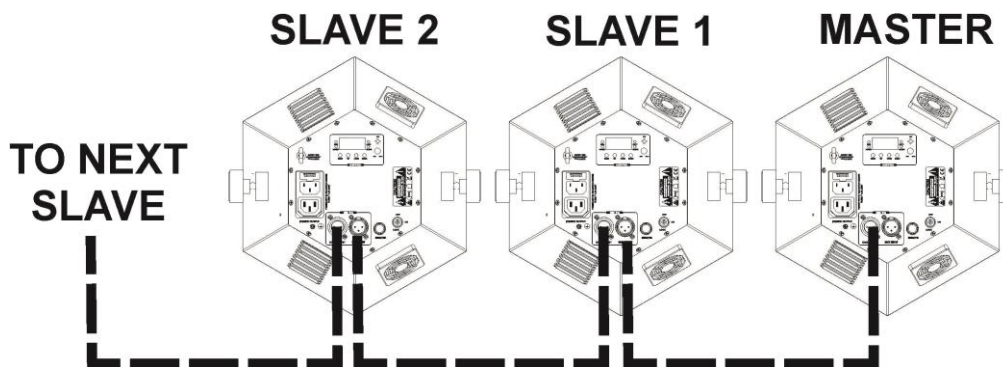

4) DMX512 MODE:

The laser can be controlled by any standard DMX-controller in 4 different DMX-modes.

- Press the [MENU] button until the display shows [dMX]
- Press the [ENTER] button
- The display will show the actual DMX address
- Press [ENTER] to enter the setup
- Use the [UP] or [DOWN] buttons to select the DMX mode you want to use. [3Ch], [9Ch], [11Ch] or [28Ch]
- Press the [ENTER] button to confirm your choice.
- Use the [UP] or [DOWN] buttons to select the desired DMX address
- Press the [ENTER] button to confirm the DMX address

Note: the display blinks when the unit is in DMX-mode and no DMX-signal is detected.

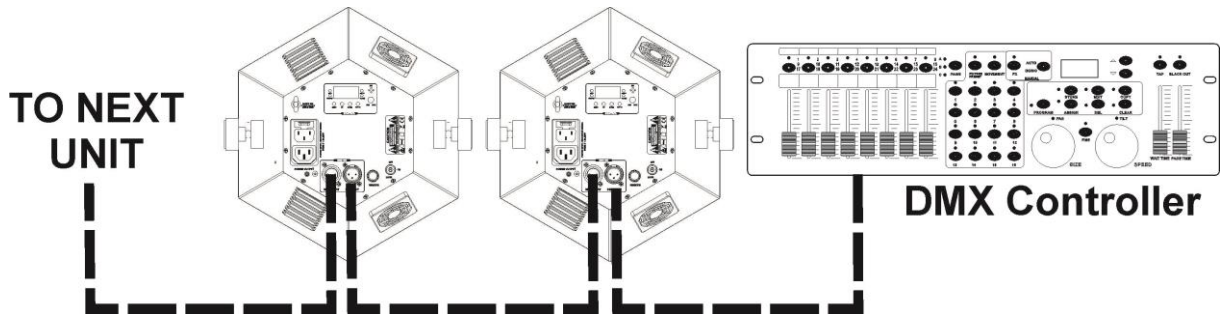

Some more information on DMX512:

The DMX-protocol is a widely used high speed signal to control intelligent light equipment. You need to “daisy chain” your DMX controller and all the connected light effects with a good quality XLR M/F balanced cable. To prevent strange behavior of the light effects, due to interferences, you must use a 90Ω to 120Ω terminator at the end of the chain. Never use Y-splitter cables, this simply won't work!

Each effect in the chain needs to have its proper starting address so it knows which commands from the controller it has to decode.

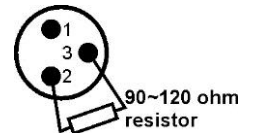

3 CHANNEL DMX-MODE:

Channel	Value	Description	
CH1	000-005	Blackout	
	006-055	Auto Wash Par/ Sound Wash Par	
	056-105	Auto Beam/ SoundBeam	
	106-155	Auto Laser/ Sound Laser	
	156-205	Auto Flash LED/ Sound Flash LED	
	206-255	Auto MIX/ Sound MIX	
CH2	Wash	000-005	Blackout
		006-032	AP01/ SP01
		033-064	AP02/ SP02
		065-096	AP03 /SP03
		097-128	AP04/ SP04
		129-160	AP05/ SP05
		161-192	AP06/ SP06
		193-224	AP07/ SP06
	225-255	AP08/ SP06	
		000-005	Blackout
		006-030	AP01/ SP01
		031-055	AP02/ SP02
		056-080	AP03 /SP03

	BEAM	081-105	AP04/ SP04	
		106-130	AP05/ SP05	
		131-155	AP06/ SP06	
		156-180	AP07/ SP06	
		181-205	AP08/ SP08	
		206-230	AP09/ SP09	
		231-255	AP10/ SP10	
	Laser	000-005	Blackout	
		006-046	AL01/ SL01	
		047-088	AL02/ SL02	
		089-130	AL03/ SL03	
		131-172	AL04/ SL04	
		173-214	AL05/ SL05	
		215-255	AL06/ SL06	
	Strobe	000-005	Blackout	
		006-032	AF01/ SF01	
		033-064	AF02/ SF02	
		065-096	AF03/ SF03	
		097-128	AF04/ SF04	
		129-160	AF05/ SF05	
		161-192	AF06/ SF06	
		193-224	AF07/ SF07	
	225-255	AF08/ SF08		
	Beam	000-005	Blackout	
		000-085	AM01/ SM01	
		086-170	AM02/ SM02	
		171-255	AM03/ SM03	
	CH3	Speed	000-250	0: slow, 255: fast
		Sound active	251-255	Sound activated show

9 CHANNEL DMX-MODE:

Channel	Value	Description	
CH1	Red	000-255	Brightness
CH2	Green	000-255	Brightness
CH3	Blue	000-255	Brightness
CH4	UV	000-255	Brightness
CH5	Wash	000-005	MANUAL (Ch 1-2-3-4 active)
		006-032	AP01/ SP01
		033-064	AP02/ SP02
		065-096	AP03 /SP03
		097-128	AP04/ SP04
		129-160	AP05/ SP05
		161-192	AP06/ SP06
		193-224	AP07/ SP07
		225-255	AP08/ SP08
		000-005	Blackout
		006-030	AP01/ SP01
		031-055	AP02/ SP02
		056-080	AP03 /SP03

CH6	Beam	081-105	AP04/ SP04
		106-130	AP05/ SP05
		131-155	AP06/ SP06
		156-180	AP07/ SP06
		181-205	AP08/ SP08
		206-230	AP09/ SP09
		231-255	AP10/ SP10
CH7	Laser	000-005	Blackout
		006-046	AL01/ SL01
		047-088	AL02/ SL02
		089-130	AL03/ SL03
		131-172	AL04/ SL04
		173-214	AL05/ SL05
CH8	Strobe	215-255	AL06/ SL06
		000-005	Blackout
		006-032	AF01/ SF01
		033-064	AF02/ SF02
		065-096	AF03/ SF03
		097-128	AF04/ SF04
		129-160	AF05/ SF05
		161-192	AF06/ SF06
CH9	Speed	193-224	AF07/ SF07
	Sound active	225-255	AF08/ SF08
CH9	Speed	000-250	0: slow, 250: fast
	Sound active	251-255	Sound activated shows

11 CHANNEL DMX-MODE:

Channel	Value	Description	
CH1	Wash	000-255	Red brightness
CH2		000-255	Green brightness
CH3		000-255	Blue brightness
CH4		000-255	UV brightness
CH5		000-100	Total Brightness
	101-250	Strobe slow to fast (0.3HZ-20HZ)	
	251-255	Strobe activated by sound	
CH6	LED	000-005	Blackout
		006-018	R
		019-032	G
		033-046	B
		047-060	A
		061-074	RG
		075-088	RB
		089-102	RA
		103-116	GB
		117-130	GA
		131-144	BA
		145-158	RGB
		159-172	RGA
173-186	RBA		

		187-200	GBA
		201-214	RGBA
		215-228	COLOR CHANGE 1
		229-242	COLOR CHANGE 2
		243-255	COLOR CHANGE 3
CH7	CH6 = 006-214	000-005	No Strobe
		006-250	Strobe slow to fast (0.3HZ-20HZ)
		251-255	Strobe activated by sound
	CH6 = 215-255	000-250	0: slow, 250: fast
		251-255	Sound activated
CH8	LASER	000-005	Black out
		006-048	R
		049-089	G
		090-131	RG
		132-173	R flash G on
		174-215	R on G flash
		216-255	RG flash
CH9		000-005	No Strobe
		006-250	Strobe slow to fast(0.3HZ-20HZ)
		251-255	Sound activated
CH10	Motor	000	Stop
		001-127	Rotate clock from slow to fast
		128	Stop
		129-255	Rotate wise-clock slow to fast
CH11	Strobe	000-005	Block out
		006-0010	On
		011-250	Strobe slow to fast (0.3HZ-20HZ)
		251-255	Sound activated

28 CHANNEL DMX-MODE:

Channel	Value	Description
CH1	Wash 1	000-255 Red brightness
CH2		000-255 Green brightness
CH3		000-255 Blue brightness
CH4		000-255 UV brightness
CH5		000-100 Total Brightness
		101-250 Strobe slow to fast (0.3HZ-20HZ)
		251-255 Strobe activated by sound
CH6	Wash 2	000-255 Red brightness
CH7		000-255 Green brightness
CH8		000-255 Blue brightness
CH9		000-255 UV brightness
CH10		000-100 Total Brightness
		101-250 Strobe slow to fast (0.3HZ-20HZ)
		251-255 Strobe activated by sound
CH11	Wash 3	000-255 Red brightness
CH12		000-255 Green brightness
CH13		000-255 Blue brightness
CH14		000-255 UV brightness
CH15		000-100 Total Brightness
		101-250 Strobe slow to fast (0.3HZ-20HZ)

		251-255	Strobe activated by sound
CH16	LED1	000-005	Blackout
		006-018	R
		019-032	G
		033-046	B
		047-060	A
		061-074	RG
		075-088	RB
		089-102	RA
		103-116	GB
		117-130	GA
		131-144	BA
		145-158	RGB
		159-172	RGA
		173-186	RBA
		187-200	GBA
		201-214	RGBA
		215-228	Color change 1
229-242	Color change 2		
243-255	Color change 3		
CH17	If 6CH is 006-214	000-005	No Strobe
		006-250	Strobe slow to fast (0.3HZ-20HZ)
		251-255	Strobe activated by sound
	If 6CH is 215-255	000-250	Show speed, 0: slow, 250: fast
		251-255	Strobe activated by sound
CH18	LED2	000-005	Blackout
		006-018	R
		019-032	G
		033-046	B
		047-060	A
		061-074	RG
		075-088	RB
		089-102	RA
		103-116	GB
		117-130	GA
		131-144	BA
		145-158	RGB
		159-172	RGA
		173-186	RBA
		187-200	GBA
		201-214	RGBA
		215-228	Color change1
229-242	Color change2		
243-255	Color change3		
CH19	CH18 = 006-214	000-005	No Strobe
		006-250	Strobe slow to fast (0.3HZ-20HZ)
		251-255	Strobe activated by sound
	CH18 = 215-255	000-250	Show speed, 0: slow, 250: fast
		251-255	Sound active
		000-005	Blackout
		006-018	R
		019-032	G
		033-046	B
		047-060	A

CH20	LED3	061-074	RG
		075-088	RB
		089-102	RA
		103-116	GB
		117-130	GA
		131-144	BA
		145-158	RGB
		159-172	RGA
		173-186	RBA
		187-200	GBA
		201-214	RGBA
		215-228	COLOR CHANGE1
		229-242	COLOR CHANGE2
		243-255	COLOR CHANGE3
CH21	CH20 = 006-214	000-005	No Strobe
		006-250	Strobe slow to fast (0.3HZ-20HZ)
		251-255	Strobe activated by sound
	CH20 = 215-255	000-250	Show speed, 0: slow, 250: fast
251-255		Sound active	
CH22	Laser	000-005	Black out
		006-048	R
		048-89	G
		090-131	RG
		132-173	R flash G on
		174-215	R on G flash
CH23		216-255	RG flash
		000-005	No Strobe
		006-250	Strobe slow to fast(0.3HZ-20HZ)
CH24	Motor	251-255	Strobe activated by sound
		0	Stop
		001-127	Rotate clock from slow to fast
		128	Stop
CH25	Strobe	129-255	Rotate wise-clock from slow to fast
		000-005	Blackout
		006-010	ON
		011-250	Strobe slow to fast(0.3HZ-20HZ)
CH26	Modes	251-255	Strobe activated by sound
		000-005	Blackout
		006-055	Auto Wash/ Sound Wash
		056-105	Auto Beam/ SoundBeam
		106-155	Auto Laser/ Sound Laser
		156-205	Auto Flash LED/ Sound Flash LED
CH27	Wash	206-255	Auto MIX/ Sound MIX
		000-005	Blackout
		006-032	AP01/ SP01
		033-064	AP02/ SP02
		065-096	AP03 /SP03
		097-128	AP04/ SP04
		129-160	AP05/ SP05
		161-192	AP06/ SP06
	193-224	AP07/ SP07	
	225-255	AP08/ SP08	
		000-005	Blackout
		006-030	AP01/ SP01

CH27	BEAM	031-055	AP02/ SP02	
		056-080	AP03 /SP03	
		081-105	AP04/ SP04	
		106-130	AP05/ SP05	
		131-155	AP06/ SP06	
		156-180	AP07/ SP06	
		181-205	AP08/ SP08	
		206-230	AP09/ SP09	
		231-255	AP10/ SP10	
	Laser	000-005	Blackout	
		006-046	AL01/ SL01	
		047-088	AL02/ SL02	
		089-130	AL03/ SL03	
		131-172	AL04/ SL04	
		173-214	AL05/ SL05	
		215-255	AL06/ SL06	
	Strobe	000-005	Blackout	
		006-032	AF01/ SF01	
		033-064	AF02/ SF02	
		065-096	AF03/ SF03	
		097-128	AF04/ SF04	
		129-160	AF05/ SF05	
		161-192	AF06/ SF06	
		193-224	AF07/ SF07	
	225-255	AF08/ SF08		
	Mixed shows	000-005	Blackout	
		000-085	AM01/ SM01	
		086-170	AM02/ SM02	
		171-255	AM03/ SM03	
	CH28	Speed	000-250	Show speed, 0: slow, 250: fast
		Sound show	251-255	Show activated by sound

IR REMOTE CONTROLLER

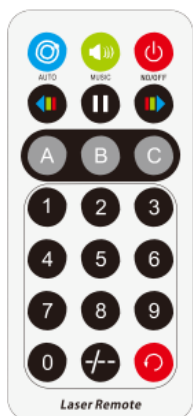

Button	Function	Description
	ON/OFF	To switch the effect On or Off
	MIX AUTO	Click several times for different programs
	MIX SOUND	Click several times for different programs
	WASH PROJECTOR	Click several times for different programs
	LASER	Click several times for different programs
	WHITE FLASH	Click several times for different programs
	AUTO / SOUND	Used to toggle between automatic and sound mode
	PAUSE	Used to pause the program
	WASH COLOR	Color selection for the Wash projectors
	SPEED	Select the speed for the automatic programs

EXTRA MENU OPTIONS

Press the [MENU] button till [SYS] appears on the display

Press [ENTER] and use the [UP] & [DOWN] buttons to browse the different options:

- **[LEdS]**: use this option to select if the display needs to go out when it is not used or if it has to be lit all the time

- **[LEdr]**: use this option to reverse the display. This can be useful when the unit is positioned upside-down.
- **[tEst]**: when you select this option, the unit will run an automatic test program, so you can easily check visually if all the Leds or lasers are still working.
- **[rEst]**: use this option to restore the initial factory settings.

MAINTENANCE

- Make sure the area below the installation place is free from unwanted persons during servicing.
- Switch off the unit, unplug the mains cable and wait until the unit has been cooled down.

During inspection the following points should be checked:

- All screws used for installing the device and any of its parts should be tightly fastened and may not be corroded.
- Housings, fixations and installations spots (ceiling, truss, suspensions) should be totally free from any deformation.
- When an optical lens is visibly damaged due to cracks or deep scratches, it must be replaced.
- The mains cables must be in impeccable condition and should be replaced immediately when even a small problem is detected.
- In order to protect the device from overheat the cooling fans (if any) and ventilation openings should be cleaned monthly.
- The interior of the device should be cleaned annually using a vacuum cleaner or air-jet.
- The cleaning of internal and external optical lenses and/or mirrors must be carried out periodically to optimize light output. Cleaning frequency depends on the environment in which the fixture operates: damp, smoky or particularly dirty surroundings can cause greater accumulation of dirt on the unit's optics.
 - Clean with a soft cloth using normal glass cleaning products.
 - Always dry the parts carefully.
 - Clean the external optics at least once every 30 days.
 - Clean the internal optics at least every 90 days.

Attention: We strongly recommend internal cleaning to be carried out by qualified personnel!

SPECIFICATIONS

This device was designed to produce decorative effect lighting and is used in light show systems. This unit is radio-interference suppressed. This product meets the requirements of the current European and national guidelines. Conformity has been established and the relevant statements and documents have been deposited by the manufacturer.

Mains Input:	AC 100~240V, 50/60Hz
Fuse:	250V 1.6A slow blow (20mm glass)
Max. Power consumption:	70W
Sound Control:	Internal microphone
DMX connections:	3pin XLR male / female
DMX channels:	3 / 9 / 11 / 28 channels
Par LEDs:	9x8Watt Red-Green-Blue-UV Led's
Beam effect LEDs:	84x0.75Watt Led's (24x Red + 18x Green + 18x Blue + 24x Amber)
Strobe LEDs:	12x 0.5Watt LEDs
Laser Power:	100mW Red ($\lambda = 650\text{nm}$) + 30mW Green laser ($\lambda = 532\text{nm}$)
Laser radiation class:	3R
Working temperature:	10°C to 40°C
Laser Safety Standard:	EN/IEC 60825-1
Size:	335x312x191mm
Weight:	3.12 kg

All the information is subject to change without prior notice
 You can download the latest version of this user manual on our website: www.jb-systems.eu

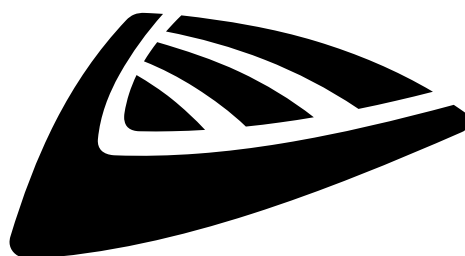

JB SYSTEMS

MAILING LIST

EN: Subscribe today to our mailing list for the latest product news!

FR: Inscrivez-vous à notre liste de distribution si vous souhaitez suivre l'actualité de nos produits!

NL: Abonneer je vandaag nog op onze mailinglijst en ontvang ons laatste product nieuws!

DE: Abonnieren Sie unseren Newsletter und erhalten Sie aktuelle Produktinformationen!

ES: Suscribete hoy a nuestra lista de correo para recibir las últimas noticias!

WWW.JB-SYSTEMS.EU

Copyright © 2017 by BEGLEC NV

t Hofveld 2C ~ B1702 Groot-Bijgaarden ~ Belgium

Reproduction or publication of the content in any manner, without express permission of the publisher, is prohibited.