



Blackmagicdesign

Installation and Operation Manual

# Blackmagic URSA Mini and URSA Mini Pro

Includes Blackmagic URSA Viewfinder, URSA Studio Viewfinder, URSA Mini Shoulder Kit, URSA Mini Lens Mounts, Blackmagic Camera Fiber Converter, Studio Fiber Converter and URSA Mini Recorder.

September 2020

English, 日本語, Français, Deutsch, Español, 中文, 한국어, Русский, Italiano, Português and Türkçe.

# Languages

To go directly to your preferred language, simply click on the hyperlinks listed in the contents below.

<a href="#">English</a>	<a href="#">3</a>
<a href="#">日本語</a>	<a href="#">293</a>
<a href="#">Français</a>	<a href="#">584</a>
<a href="#">Deutsch</a>	<a href="#">875</a>
<a href="#">Español</a>	<a href="#">1166</a>
<a href="#">中文</a>	<a href="#">1457</a>
<a href="#">한국어</a>	<a href="#">1748</a>
<a href="#">Русский</a>	<a href="#">2039</a>
<a href="#">Italiano</a>	<a href="#">2330</a>
<a href="#">Português</a>	<a href="#">2621</a>
<a href="#">Türkçe</a>	<a href="#">2912</a>



## Welcome

Thank you for purchasing Blackmagic URSA Mini!

Since we released our first digital film camera a few years ago we have been privileged to have received some of the best guidance and feedback we have ever had for a new product! We all grew up admiring the work of the world's leading cinematographers and DOPs and it's been an honor to spend hours in conversations with these legendary experts on the features we need to add to our cameras. Of course, everyone we speak to has good ideas also!

With URSA Mini, we've packaged our incredible wide dynamic range sensors into a super small, light and sturdy metal chassis.

URSA Mini's beautiful user interface is designed for single operators who need quick, easy access to all of their camera's functions, while comprehensive ATEM switcher integration makes the amazing image quality of this Super 35mm digital film camera available to live production studios. You can even use Blackmagic Fiber Converters, so you can use a single SMPTE fiber cable to connect an URSA Mini to your live production switcher!

Best of all, URSA Mini is available with a 4K sensor, 4.6K sensor with even greater dynamic range or the revolutionary 12K sensor! We also listened to single operators when we developed our Blackmagic URSA Viewfinder which is perfect when you need extra precision and for shooting on the shoulder.

URSA Mini Pro offers even better image quality with additional features including ergonomic controls, interchangeable lens mounts and internal ND filters. If you are familiar with ENG cameras, we believe you will find these ergonomic controls and the built in ND filters extremely powerful. We're also proud to introduce our Blackmagic RAW codec, offering the flexibility of RAW processing all in a single file, providing massive performance increases with reduced file sizes, even when handling powerful images from Blackmagic URSA Mini Pro 12K!

We hope you use your URSA Mini or URSA Mini Pro to produce some of the world's most exciting films and television programming, music videos and commercials! We are extremely excited to see what creative work you produce and to get your feedback on new features you would like to see us add to URSA!

A handwritten signature in black ink that reads "Grant Petty". The signature is written in a fluid, cursive style.

**Grant Petty**

CEO Blackmagic Design



# Contents

<b>Which camera are you using?</b>	6	<b>Touchscreen Controls</b>	73
URSA Mini Pro	7	<b>Settings</b>	95
URSA Mini	8	Dashboard	95
<b>Getting Started</b>	8	Record Settings	96
Attaching a Lens	8	File Naming Convention	102
Powering your Camera	12	Monitor Settings	103
<b>Storage Media</b>	15	Audio Settings	112
CFast Cards	15	Audio Settings – URSA Mini	112
SD Cards	19	Audio Settings – URSA Mini Pro	114
USB-C flash disks	24	Setup Settings	116
SSDs	26	Presets	130
Preparing Media for Recording	28	LUTS	132
Preparing Media on		<b>Entering Metadata</b>	136
Blackmagic URSA Mini	28	<b>Using Servo Zoom Lenses</b>	142
Preparing Media on		<b>Camera Video Output</b>	145
Blackmagic URSA Mini Pro	30	HD Monitoring Output	145
Preparing Media on Mac	31	12G-SDI Output	145
Preparing Media on Windows	32	<b>URSA Mini Shoulder Mount Kit</b>	147
<b>Recording</b>	33	<b>Blackmagic URSA Viewfinder</b>	151
Recording Clips	33	Mounting and Connecting	
Choosing the Codec,		to Blackmagic URSA	151
Resolution and Sensor Area	33	Adjusting the Eyepiece	152
Blackmagic RAW	35	Button Features	152
Recording to Blackmagic RAW	36	Menu Settings	153
Choosing Frame Rates	39	<b>Blackmagic URSA Studio Viewfinder</b>	158
Trigger Record	42	Mounting and Connecting	
Record Duration Tables	43	to Blackmagic URSA Mini	159
Data Rate Tables for URSA Mini Pro 12K	46	Adjusting the Blackmagic URSA	
<b>Playback</b>	49	Studio Viewfinder	161
<b>Introduction to URSA Mini</b>	51	Button Features	164
Camera Front	51	Menu Settings	166
Left Side – URSA Mini	52	<b>Mounting Batteries</b>	171
Left Side – URSA Mini Pro	52	Mounting V-mount or	
Right Side	54	Gold Mount Batteries	171
Rear Panel	55	Using your own Battery Plate	172
Top Panel	57	<b>Blackmagic Fiber Converters</b>	174
Underside	57	<b>Getting Started with</b>	
<b>URSA Mini Controls</b>	58	<b>Blackmagic Fiber Converters</b>	175
<b>URSA Mini Pro Control Buttons</b>	61	About SMPTE Fiber	175
Forward Control Panel	61	Connecting SMPTE Fiber	177
Ergonomic Control Panel	65	Connecting to an ATEM Switcher	180
Internal Control Panel	70	Why Connections on the Front?	181
		Plugging in Camera SDI	182



Plugging in Return SDI Outputs	182	Editing with the Cut Page	222
Mounting Blackmagic Camera Fiber Converter	182	Adding Clips to the Timeline	225
Attaching the URSA Studio Viewfinder	185	Editing Clips on the Timeline	226
Plugging in a Talkback Headset	185	Adding Titles	226
<b>Operating the Camera Fiber Converter</b>	186	Working with Blackmagic RAW Files	227
Selecting a Return Feed	186	Color Correcting your Clips with the Color Page	230
Using the Call Button	187	Adding a Power Window	234
Using Talkback	187	Using Plugins	235
Using Tally	188	Mixing Your Audio	236
Status Indicators	188	Adding VFX and Compositing on the Fusion Page	241
Audio Inputs	189	Mastering Your Edit	249
IP Video	190	Quick Export	249
Power Specifications	190	The Deliver Page	250
Additional Camera Controls	191	<b>Understanding Studio Camera Control</b>	251
<b>Operating the Studio Fiber Converter</b>	192	Using Camera Control	252
Using the Menu	193	DaVinci Resolve Primary Color Corrector	258
Rack Mounting the Studio Unit	196	<b>Blackmagic Camera Setup Utility</b>	261
<b>Camera Unit Connections</b>	200	<b>Working with Third Party Software</b>	263
Camera Power Connection	200	Working with Files from CFast 2.0 and SD cards	263
PTZ Interface	200	Working with Files from SSDs	264
Talkback Connection	201	Using Final Cut Pro X	264
Tracker Interface	202	Using Avid Media Composer 2018	265
DC Connection	202	Using Adobe Premiere Pro CC	266
D-Tap Output	203	<b>Developer Information</b>	267
Reference Output and Operation	203	Blackmagic Bluetooth Camera Control	267
<b>Studio Unit Connections</b>	204	Blackmagic SDI and Bluetooth Camera Control Protocol	269
12G-SDI Output	204	Example Protocol Packets	276
Return SDI Inputs	204	Blackmagic Tally Control Protocol	276
Reference Input and Output	205	<b>Blackmagic URSA Mini B4 Mount</b>	279
Talkback Interface	205	<b>Shimming Lens Mounts</b>	281
PTZ Interface	207	Shimming URSA Mini PL	281
Audio Outputs	207	Shimming URSA Mini Pro	283
<b>Updating Internal Software</b>	208	<b>URSA Mini Recorder</b>	284
Updating Blackmagic Camera Fiber Converter	208	Mounting and connecting URSA Mini Recorder	285
Updating Blackmagic Studio Fiber Converter	208	Using URSA Mini Recorder	287
<b>Interchangeable Lens Mount</b>	209	Updating URSA Mini Recorder's internal software	288
Blackmagic URSA Mini Pro PL Mount	211	<b>Help</b>	289
Blackmagic URSA Mini Pro F Mount	213	<b>Regulatory Notices</b>	290
Blackmagic URSA Mini Pro EF Mount	216	<b>Safety Information</b>	291
Blackmagic URSA Mini Pro B4 Mount	218	<b>Warranty</b>	292
Blackmagic URSA Mini Pro Shim Kit	220		
<b>Using DaVinci Resolve</b>	221		
Project Manager	221		

# Which camera are you using?

You'll notice while reading this manual that occasionally a feature will be specific to a particular Blackmagic URSA Mini camera. All URSA Mini cameras produce incredible, wide dynamic range images and share the same basic chassis. There are some differences between different models, though.

## The available models are

- URSA Mini Pro 12K
- URSA Mini Pro 4.6K G2
- URSA Mini Pro 4.6K
- URSA Mini 4.6K
- URSA Mini 4K

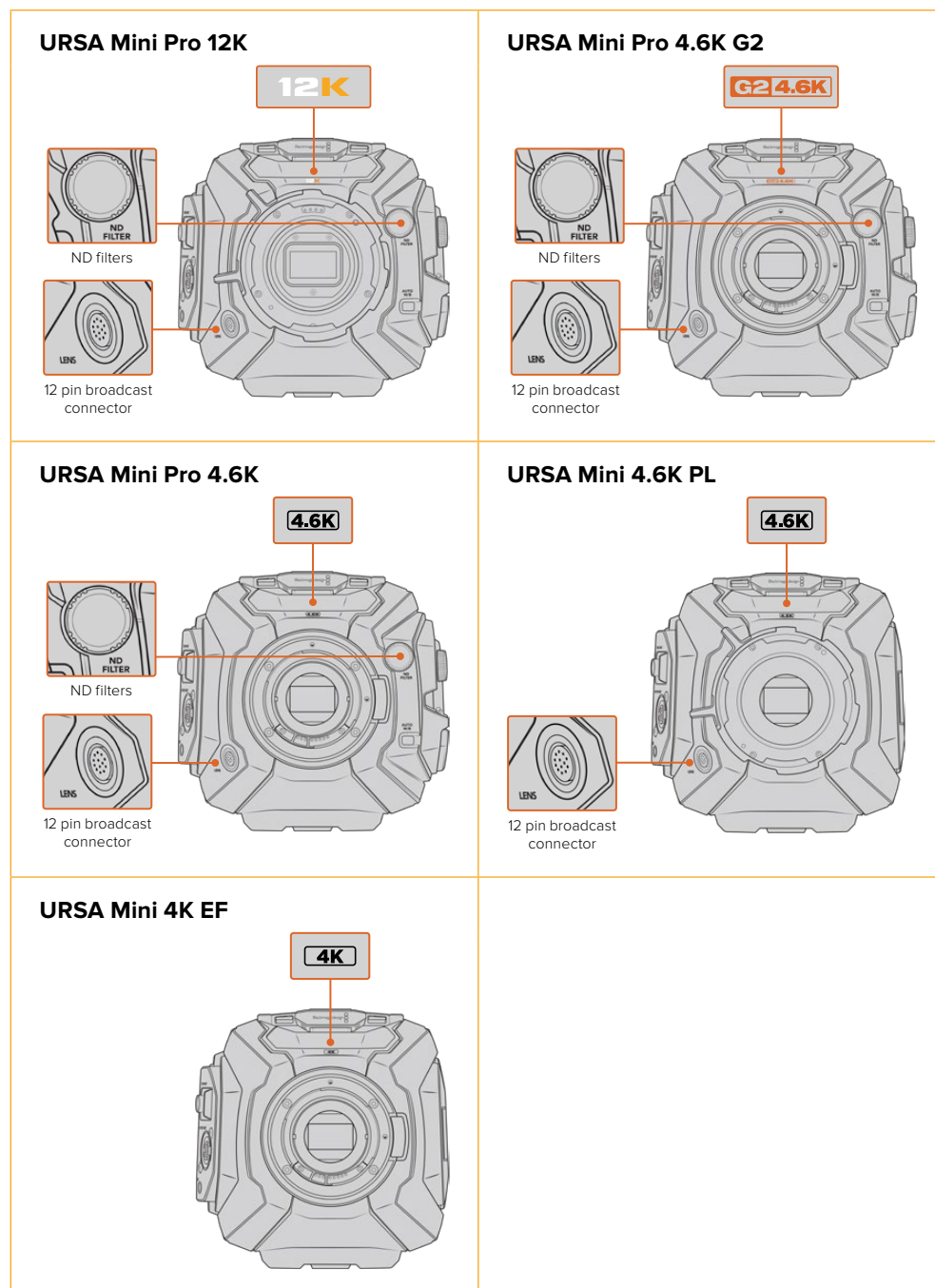

## URSA Mini Pro

URSA Mini Pro 12K comes with a PL mount, and URSA Mini Pro 4.6K G2 and URSA Mini Pro 4.6K come with an EF mount. You can change the lens mount on all URSA Mini Pro cameras to accept other lens types. For more information on the interchangeable lens mount, see the 'interchangeable lens mount' section.

URSA Mini Pro is easy to recognize by the additional control buttons and LCD status screen on the left side of the chassis, as well as the ND filters near the lens mount. URSA Mini Pro 4.6K G2 also features an orange 'G2 4.6K' icon on the front above the lens mount and an orange 'G2' icon on the left side of the external control panel. Naturally, the additional control buttons will mean that you have different options for controlling your camera and changing settings. On the side of URSA Mini Pro 12K's external control panel is a '12K' icon and 'HDR' icon. The rear panel of URSA Mini Pro 12K has the headphone socket on the top right corner above the SDI ports, and a USB-C port is located in the bottom right corner below the 12V power connector.

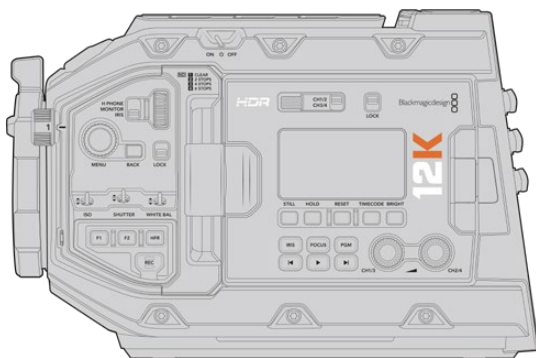

URSA Mini Pro 12K, left side

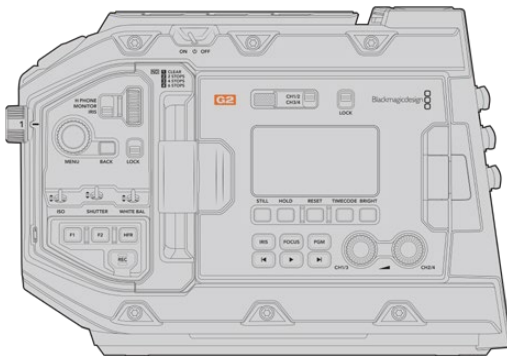

URSA Mini Pro 4.6K G2, left side

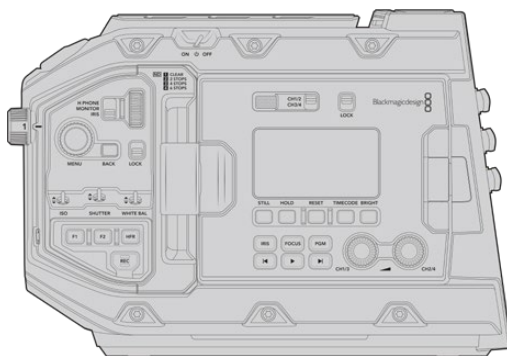

URSA Mini Pro 4.6K, left side



## URSA Mini

Aside from the sensors used, URSA Mini 4K and 4.6K models are nearly identical. The control buttons and software menus are laid out the same way, and operating the cameras is essentially the same. You'll simply find a few more resolution options on cameras using the 4.6K sensor, together with a greater range of ISO settings. An easy way to tell which sensor your camera has is to look for a '4K' or '4.6K' icon above the lens mount.

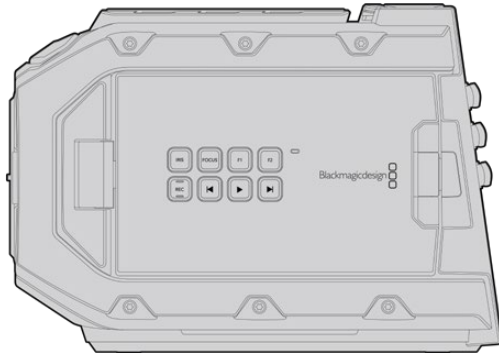

URSA Mini, left side

It's also worth noting that URSA Mini cameras are available with EF and PL lens mounts. An easy way to tell the difference between these is the presence of a 12 pin broadcast lens connector near the lens mount on PL models, and of course, the mounts themselves if you are familiar with EF and PL mounting systems. See the 'getting started' section for more information on these mounts.

Now that you know how to identify the different URSA Mini models, you can get started using your camera!

## Getting Started

Getting started with your Blackmagic URSA Mini is as simple as mounting a lens, and powering your camera.

### Attaching a Lens

Attaching a lens to your camera is the same process for all URSA Mini cameras, however the EF, PL, B4 and F mounts have slightly different ways of operating. In all cases, the first step is to remove the protective dust cap.

To remove the protective dust cap from the EF lens mount, hold down the locking button and rotate the cap counterclockwise until it is released. For the PL and B4 mount lenses, rotate the locking ring counterclockwise and pull the protective dust cap away from the mount. For the F mount, hold down the locking button and rotate the cap clockwise until it is released.

**NOTE** Blackmagic URSA Mini Pro features an interchangeable lens mount capable of accepting EF, PL, B4 and F mount lenses, as well as additional lens mounts with accessories. For more information on switching between mount types on URSA Mini Pro, refer to the 'interchangeable lens mount' section in this manual.

**TIP** URSA Mini Pro 12K comes equipped with a PL mount. Other URSA Mini Pro cameras come out of the box configured to accept EF lenses. To get shooting right away, simply attach a lens as detailed below.

#### To attach an EF mount lens:

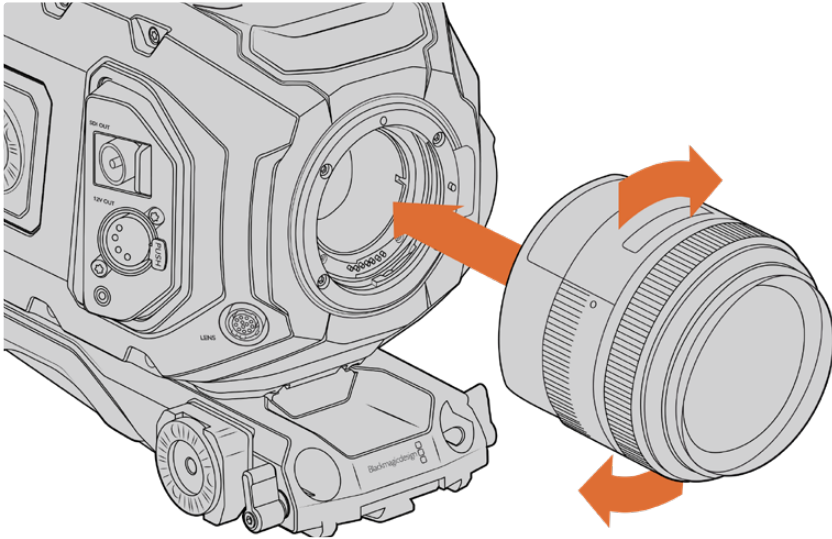

Attaching and removing an EF mount lens on Blackmagic URSA Mini EF

- 1 Align the dot on your lens with the dot on the camera mount. Many lenses have a visual indicator, for example a blue, red or white dot.
- 2 Insert the lens into the mount and twist clockwise until it locks into place.
- 3 To remove the lens, hold down the locking button, rotate the lens counterclockwise until its dot or indicator reaches the 12 o'clock position, and gently remove.

#### To attach a PL mount lens:

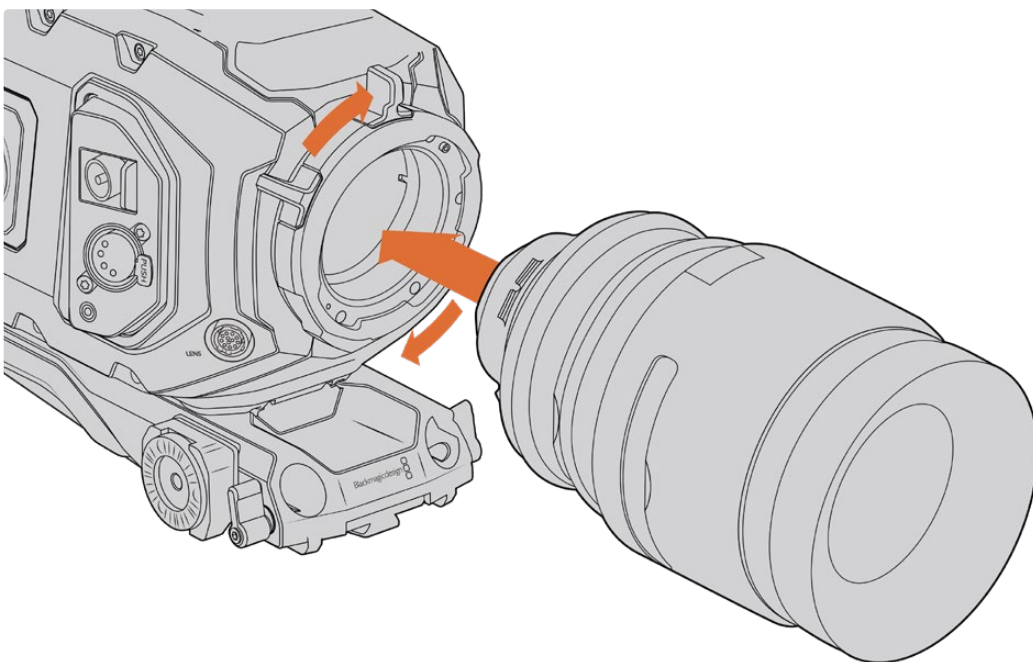

Attaching and removing a PL lens on Blackmagic URSA Mini PL and URSA Mini Pro 12K

- 1 Open your camera's PL locking ring by rotating it counterclockwise until it stops.
- 2 Align one of the lens' four flange notches with the locating pin on the camera mount. Be sure to align the lens for easy viewing of the lens marks.
- 3 Tighten the PL locking ring by rotating it clockwise. If attaching a PL lens with a servo unit to URSA Mini PL or URSA Mini Pro, you can also connect the 12 pin broadcast connector for servo control.
- 4 To remove the lens, rotate the locking ring counterclockwise until it stops, then gently remove the lens by pulling it directly out from the camera body. There is no need to rotate the lens.

### URSA Mini Pro PL Mount

URSA Mini Pro's PL mount features four pins at the 12 o'clock position that are used to communicate with lenses featuring Cooke's /i Technology interface. The lenses that support this interface include lenses from Canon, Cooke, Fujinon, Leica and Zeiss. This lets you record lens information in your clips' metadata such as the lens model, focal length, aperture setting, focus distance and other lens specific information.

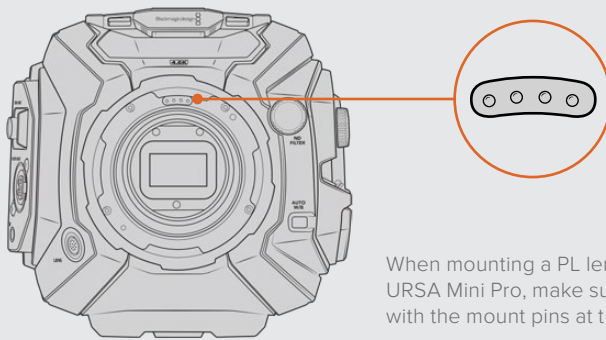

When mounting a PL lens with /i Technology to URSA Mini Pro, make sure the lens pins align with the mount pins at the 12 o'clock position

The information that is recorded as metadata via Cooke's /i Technology interface can be very helpful in post production and VFX. Knowing the lenses used in production and their precise settings can be helpful in the event that the setup needs to be replicated at a later date.

This detailed information can also be utilized by powerful applications such as DaVinci Resolve and Blackmagic Fusion for a wide variety of advanced functions. For example, the recorded metadata can be used to simulate the specific lens in 3D space, or correct lens distortions.

URSA Mini Pro and URSA Mini PL support control of PL 35mm lenses with servo handgrips. When the lens is plugged in to the 12-pin broadcast connector on the camera, URSA Mini will provide power and control signals to your lens in the same way it does with B4 lenses. For more information refer to the 'Using Servo Zoom Lenses' section in this manual.

**NOTE** When no lens is attached to the camera, the glass filter covering the sensor is exposed to dust and other debris. Ensure that you keep the dust cap on whenever possible.



### To attach a B4 mount lens:

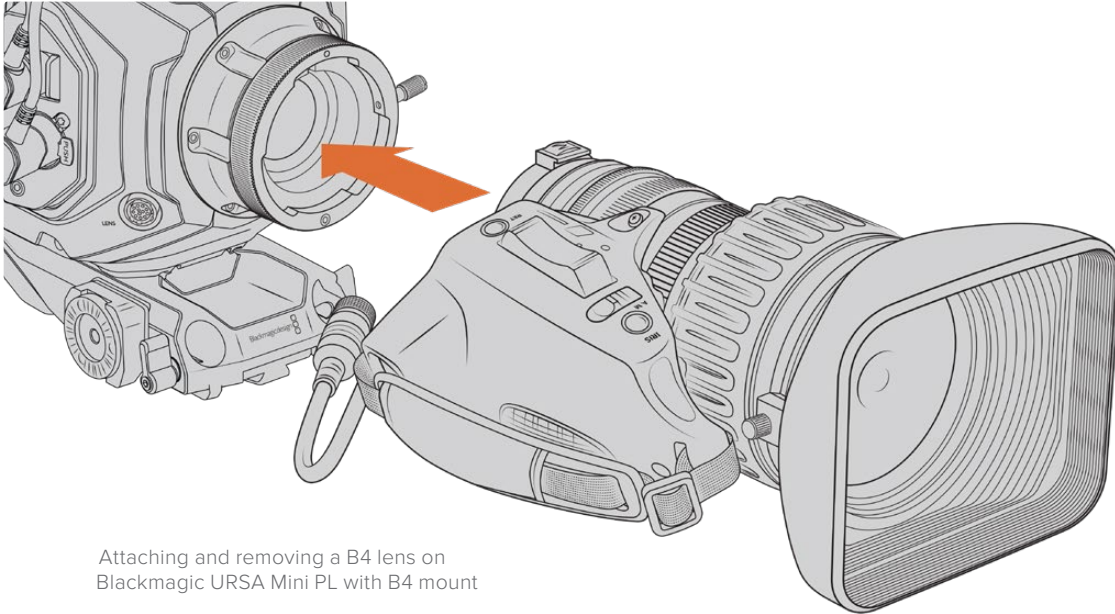

Attaching and removing a B4 lens on Blackmagic URSA Mini PL with B4 mount

- 1** Turn the B4 lens locking ring counterclockwise to reveal the alignment slot inside the top of the mount. Align the B4 lens to your URSA Mini's B4 mount so the alignment pin on the lens mount matches the position of the alignment slot.
- 2** Hold the lens against the B4 mount so the mount plates are against each other. Make sure the alignment pin is secured inside the alignment slot.
- 3** Turn the locking ring clockwise to tighten the lens against the mount and lock it into position.
- 4** To power the lens and provide lens control, simply plug the lens cable into the connector marked 'Lens' on the front of your URSA Mini PL or URSA Mini Pro's turret. Most B4 lenses will have the 12 pin connector and cable built in. This will provide power and control signals from your URSA Mini to the lens.

For information on the types of B4 lenses and how to use them with your camera, refer to the 'Using Servo Zoom Lenses' section in this manual.

### To attach an F mount lens:

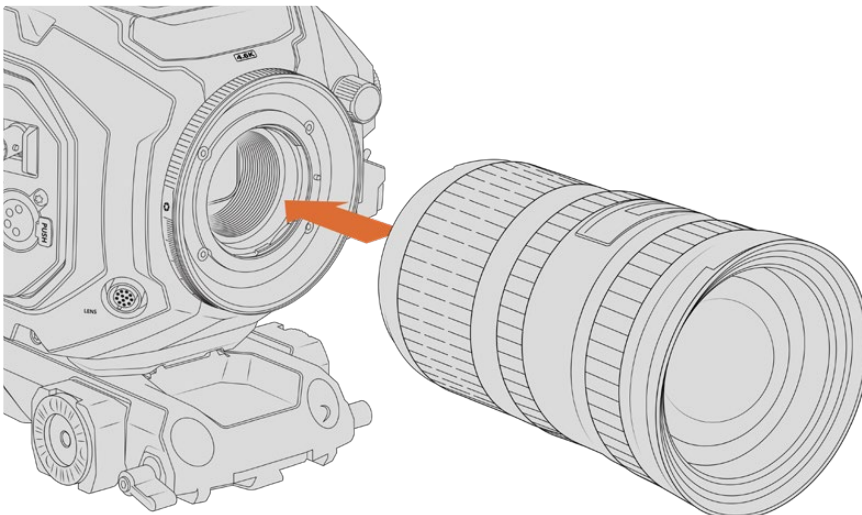

Attaching and removing an F mount lens on Blackmagic URSA Mini Pro 4.6K with the optional F mount fitted

- 1 Align the dot on your lens with the dot on the camera mount. Many lenses have a visual indicator, for example a blue, red or white dot.
- 2 Insert the lens into the mount and twist counterclockwise until it locks into place.
- 3 To remove the lens, hold down the locking button, rotate the lens clockwise until its dot or indicator reaches the 2 o'clock position, and gently remove.

**NOTE** Blackmagic URSA Mini Pro F mount features a mechanical iris adjuster. To use older style F mount lenses with built in focus rings with this mount, your lens aperture will need to be set and locked to its smallest setting, such as f/22. For more information on adjusting aperture with Blackmagic URSA Mini Pro F mount's manual iris adjuster, see the section 'Blackmagic URSA Mini Pro F Mount' in this manual.

## Powering your Camera

Now that you've attached a lens, you will need to supply power. The quickest way to power your camera is to connect external power using the supplied AC to 12V DC adapter.

### To plug in external power:

- 1 Connect the AC to 12V DC adapter plug to your mains power socket.
- 2 Connect the AC to 12V DC adapter's 4 pin XLR connector to the 12-20V DC power connector on the camera.

If you have both external and battery power connected, only external power will be used. If you remove external power while a charged battery is connected, your camera will switch to battery power without interruption.

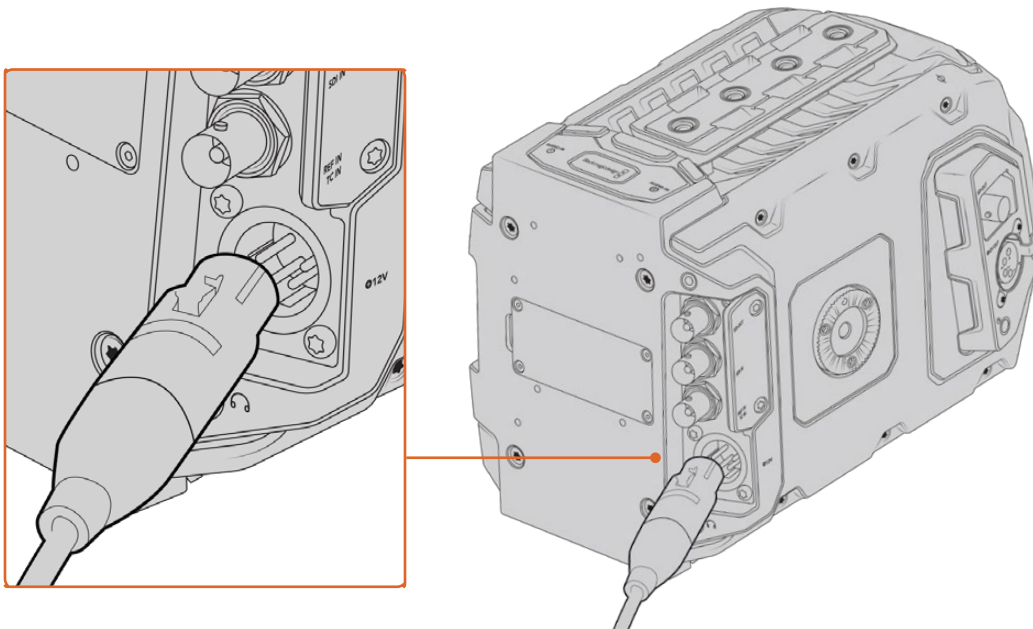

Use the supplied AC to 12V DC adapter to power your Blackmagic URSA Mini

You can use industry standard third party external batteries such as V mount or Gold Mount batteries with your URSA Mini. Refer to the 'mounting batteries' section for more information about mounting the different types of battery plates to support different batteries.

### To turn on URSA Mini:

- 1 Press and release the 'power' button. On Blackmagic URSA Mini, the power button is located on the control panel behind the fold out LCD. Simply open the LCD to access the control panel.
- 2 Press and hold the 'power' button to turn your camera off.

You are now ready to insert CFast 2.0 cards and start recording!

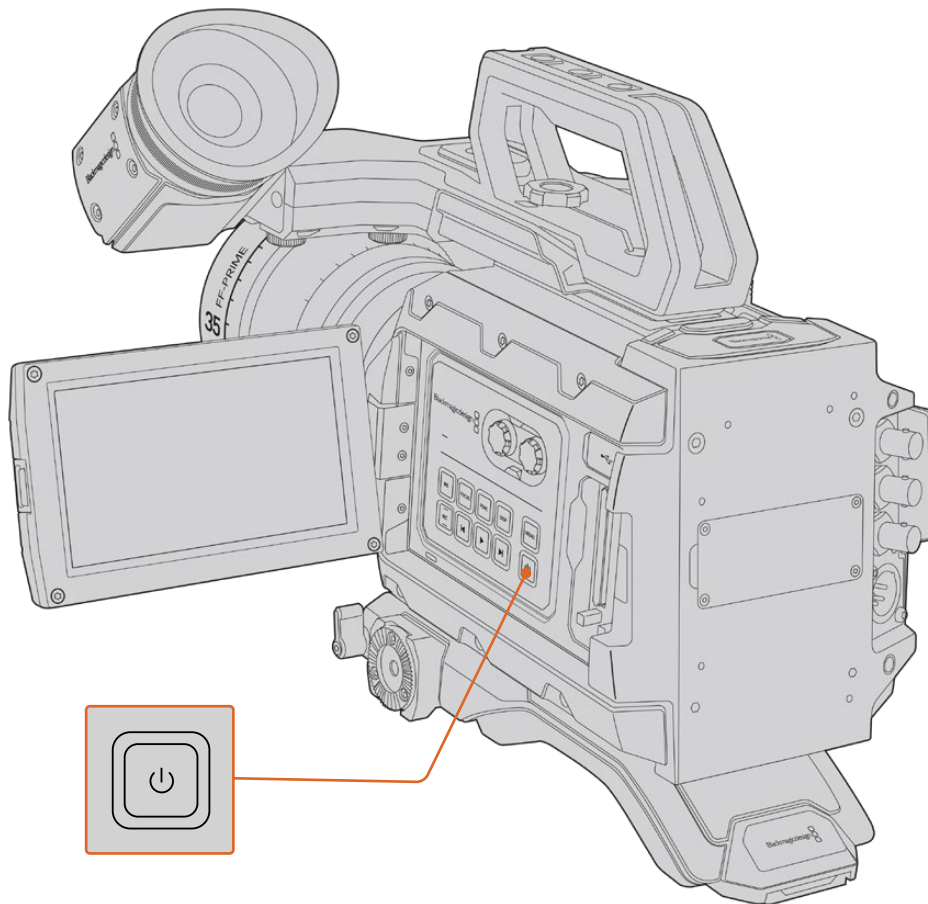

To turn on your URSA Mini, open the fold out LCD touchscreen, then press and release the power button on the control panel. Press and hold to turn off

**TIP** When turning the camera on, make sure you promptly press and release the button. Your camera will take approximately 10 seconds to boot up, but there is no need to press the button again. When turning off, press and hold the button until the camera powers off.



## To turn on URSA Mini Pro:

- 1 On Blackmagic URSA Mini Pro, a power switch is also located above the fold out LCD. Move the switch to the 'on' position to power your camera.
- 2 To turn the camera off, move the switch to the 'off' position.

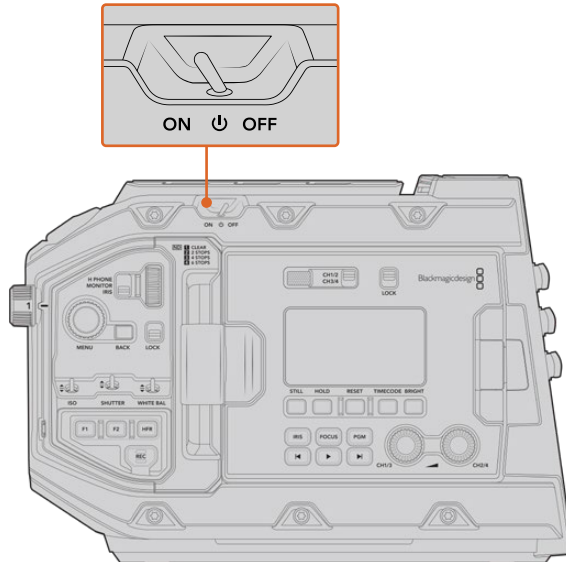

Move the power switch to 'on' to power your camera

URSA Mini Pro also features a redundant power switch, which allows the camera to be turned on and off by briefly holding down the 'rec' and 'forward skip' buttons on the inside control panel. While you wouldn't normally power your camera using this method, it is provided as a helpful alternative if the power switch along the top edge is obscured, for example when mounted on a custom rig.

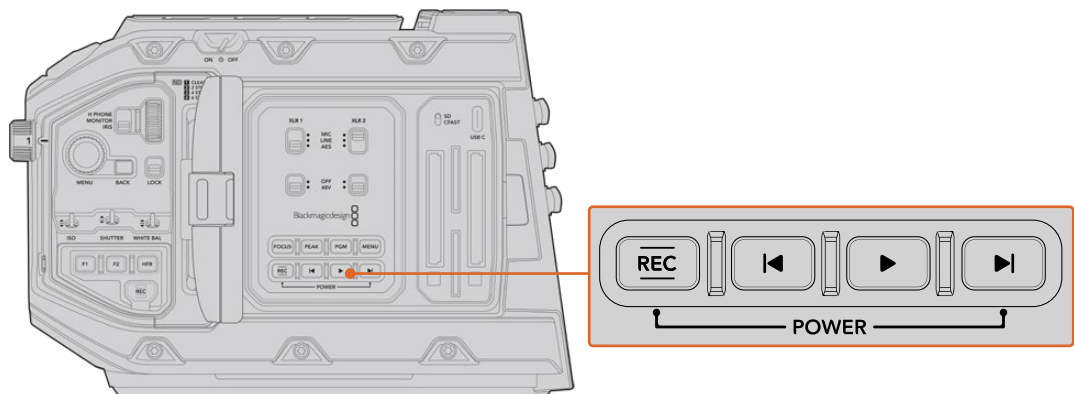

If you need to, you can also briefly hold down the record and forward skip buttons on the control panel behind the LCD to power your camera on or off

**TIP** If your URSA Mini Pro is turned off when the power switch is set to 'on', your camera may have been powered down via *Bluetooth*® control or by holding down the record and forward skip control panel buttons. Simply toggle the power switch 'off' and 'on,' or hold down the relevant control panel buttons to power the camera on.

# Storage Media

Your Blackmagic URSA Mini camera has a number of storage options. All URSA Mini cameras use CFast 2.0 cards to record video. URSA Mini Pro cameras can also record to fast UHS-II and UHS-I SD cards.

URSA Mini Pro G2 has a USB-C 3.1 Gen 1 port and URSA Mini Pro 12K has a USB-C 3.1 Gen 2 port for recording to high speed flash disks or high capacity solid state drives, or “SSDs” using the optional URSA Mini Recorder.

**NOTE** URSA Mini Recorder is designed for use with URSA Mini Pro 12K and is compatible with URSA Mini Pro 4.6K G2. It is not compatible with URSA Mini Pro 4.6K, URSA Mini 4.6K and URSA Mini 4K. For more information on connecting URSA Mini Recorder to your camera see the ‘Blackmagic URSA Mini Recorder’ section.

## Important Notes About Media Speeds

Write and read speeds published by recording media manufacturers are often based on peak speeds for small files such as still images, and may not accurately reflect write speeds for a continuous stream of high speed video.

Blackmagic has thoroughly tested all of the cards listed below for URSA Mini. For reliable recording with your chosen frame rates, use only the cards recommended by Blackmagic Design.

## CFast Cards

CFast 2.0 cards are capable of supporting very high data rates, so are perfect for recording HD and 4K video at high frame rates. Refer to the record duration table in the ‘recording’ section for details on the maximum frame rates that can be recorded in each format.

**NOTE** While CFast 2.0 cards are generally high speed cards, some cards have slower write speeds compared to read speeds, and maximum data rates can differ between models. To ensure reliable recording in your chosen frame rates, use only the recommended cards listed in this section.

## Inserting a CFast Card

If you’re using URSA Mini Pro, your camera can record to CFast cards or SD cards. To record using CFast cards you need to set your camera accordingly. To do this, set the storage media switch above the media slots to the ‘CFAST’ position.

**To insert a CFast card:**

- 1 Open the fold out monitor to access the CFast slots.
- 2 Insert the CFast card into the CFast card slot until you feel it lock into place. The card should insert easily without the need for excessive force. Push the CFast card ejector button to eject the card.

The storage information at the bottom of the LCD touchscreen will show the name and record time remaining of the detected CFast cards.

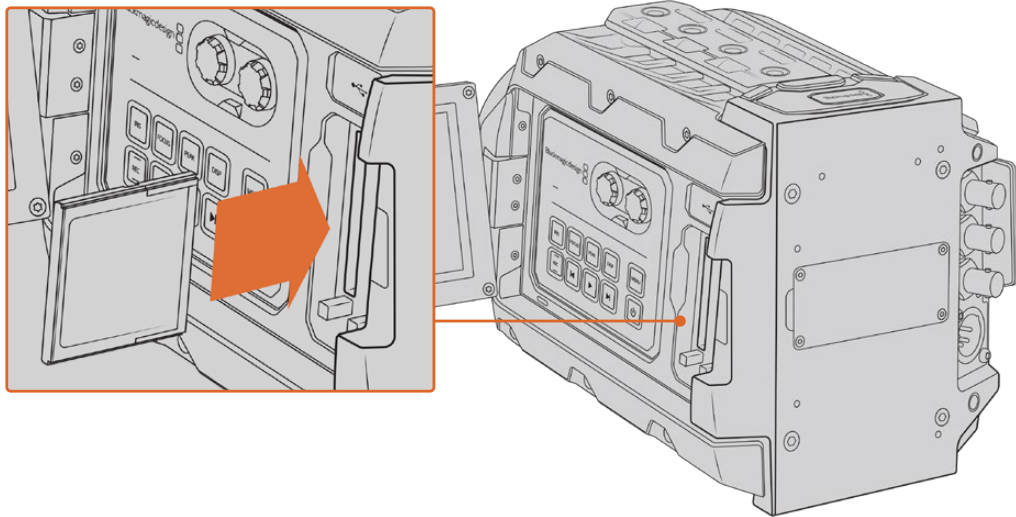

Blackmagic URSA Mini has two CFast slots for continuous recording

**Choosing a CFast 2.0 Card**

When working with high data rate video it's important to carefully check the CFast card you would like to use. This is because CFast 2.0 cards have different read and write speeds. The tables below identify the CFast cards recommended for use.

**Which CFast cards should I use with Blackmagic URSA Mini Pro 12K?**

The following CFast 2.0 cards are recommended for recording 12K DCI Blackmagic RAW 18:1 up to 60 frames per second, and 8K DCI Blackmagic RAW 8:1 up to 60 frames per second.

Brand	Card Name	Storage
Angelbird	AV Pro CF	128GB
Angelbird	AV Pro CF	256GB
Angelbird	AV Pro CF	512GB
Angelbird	AV Pro CF	1TB
ExAscend	Essential	512GB
ExAscend	Essential	1TB
FreeTail	Evoke Pro 3700x	128GB
FreeTail	Evoke Pro 3700x	256GB
FreeTail	Evoke Pro 3700x	512GB
FreeTail	Evoke Pro 3700x	1TB

Brand	Card Name	Storage
KomputerBay	x3400 CFast 2.0	128GB
ProGrade Digital	550MB/s CFast 2.0	256GB
ProGrade Digital	550MB/s CFast 2.0	512GB
SanDisk	Extreme Pro CFast 2.0 SDCFSP-128G-x46D	128GB
Wise	CFast 2.0 3400x	256GB
Wise	CFast 2.0 3500x	512GB
Wise	CFast 2.0 3500x	1TB

### Which CFast cards should I use with the Blackmagic URSA Mini and URSA Mini Pro Cameras?

The following CFast 2.0 cards are recommended for recording 4.6K Blackmagic RAW 3:1 up to 60 fps.

Brand	Card Name	Storage
Angelbird	AV Pro CF	128GB
Angelbird	AV Pro CF	256GB
Angelbird	AV Pro CF	512GB
Angelbird	AV Pro CF	1TB
CinediskPro	510MB/s CFast 2.0	256GB
FreeTail	Evoke Pro 3700x	128GB
FreeTail	Evoke Pro 3700x	256GB
FreeTail	Evoke Pro 3700x	512GB
FreeTail	Evoke Pro 3700x	1TB
Hagiwara Solutions	CFast 2.0 DC-SMAN64GA	64GB
Hagiwara Solutions	CFast 2.0 DC-SMANA1GA	128GB
KomputerBay	3600x CFast 2.0 Card	64GB
ProGrade Digital	550MB/s CFast 2.0	64GB
ProGrade Digital	550MB/s CFast 2.0	128GB
ProGrade Digital	550MB/s CFast 2.0	256GB
ProGrade Digital	550MB/s CFast 2.0	512GB
SanDisk	Extreme Pro CFast 2.0 SDCFSP-128G-x46D	128GB
SanDisk	Extreme Pro CFast 2.0 SDCFSP-256G-x46D	256GB
SanDisk	Extreme Pro CFast 2.0 SDCFSP-512G-x46D	512GB
Sony	CFast 2.0 G Series CAT-G64	64GB
Sony	CFast 2.0 G Series CAT-G128	128GB

Brand	Card Name	Storage
Transcend	CFX650 CFast 2.0 TS128GCFX650	128GB
Transcend	CFX650 CFast 2.0 TS256GCFX650	256GB
Transcend	CFX650 CFast 2.0 TS128GCFX650BM	128GB
Transcend	CFX650 CFast 2.0 TS256GCFX650BM	256GB
Wise	CFast 2.0 3400x	256GB
Wise	CFast 2.0 3500x	512GB

The following CFast 2.0 cards are recommended for recording 2160p ProRes 422 HQ up to 60 fps.

Brand	Card Name	Storage
Angelbird	AV Pro CF	128GB
Angelbird	AV Pro CF	256GB
Angelbird	AV Pro CF	512GB
Angelbird	AV Pro CF	1TB
Angelbird	AV Pro CF XT	256GB
Angelbird	AV Pro CF XT	512GB
CinediskPro	510MB/s CFast 2.0	256GB
Hagiwara Solutions	DC-SMAN64GA	64GB
Hagiwara Solutions	DC-SMANA1GA	128GB
KomputerBay	3600x CFast 2.0 Card	64GB
KomputerBay	3700x CFast 2.0 Card	256GB
ProGrade Digital	550MB/s CFast 2.0	128GB
ProGrade Digital	550MB/s CFast 2.0	256GB
ProGrade Digital	550MB/s CFast 2.0	512GB
SanDisk	Extreme Pro CFast 2.0 SDCFSP-128G-x46D	128GB
SanDisk	Extreme Pro CFast 2.0 SDCFSP-256G-x46D	256GB
SanDisk	Extreme Pro CFast 2.0 SDCFSP-512G-x46D	512GB
Silicon Power	CFX310	256GB
Sony	CFast 2.0 G Series CAT-G64	64GB
Sony	CFast 2.0 G Series CAT-G128	128GB
Transcend	CFX650 CFast 2.0 TS128GCFX650	128GB
Transcend	CFX650 CFast 2.0 TS256GCFX650	256GB



Brand	Card Name	Storage
Transcend	CFX650 CFast 2.0 TS128GCFX650BM	128GB
Transcend	CFX650 CFast 2.0 TS256GCFX650BM	256GB
Wise	CFast 2.0 3400x	128GB
Wise	CFast 2.0 3400x	256GB
Wise	CFast 2.0 3500x	512GB

For the most up to date information on supported CFast cards for Blackmagic URSA Mini please refer to the Blackmagic Design support center at [www.blackmagicdesign.com/support](http://www.blackmagicdesign.com/support).

**NOTE** Only the ‘D-series’ of Sandisk CFast 2.0 cards have been certified for use with Blackmagic URSA Mini cameras. These cards can be identified by a large ‘D’ printed on the back of the card in the lower left corner, and we have also listed the model numbers to make them easier to identify. This model number varies slightly from region to region, with the ‘x’ in the model number changing in different markets. For example, an ‘A’ in the United States and a ‘G’ in the Asia Pacific and Europe region.

## SD Cards

In addition to CFast 2.0 cards, Blackmagic URSA Mini Pro can record on high speed UHS-I and UHS-II type SD cards. Using high end SDXC UHS-II cards, you can even record ProRes HQ footage in 2160p for Ultra HD content!

With SD cards, you can use more affordable storage media when shooting compressed video formats in HD. SDXC and SDHC are a very common media storage format for consumer still and video cameras.

If you’ve ever shot video using a DSLR, or use a Blackmagic Micro Cinema Camera, Pocket Cinema Camera 4K or Blackmagic Video Assist, you probably already have compatible SD cards to use.

For projects that don’t require the highest resolution Blackmagic RAW files, or for when long recording durations are needed, using SD cards can be very economical. Lower capacity and lower speed SD cards can also be used for storing and loading LUTs and presets.

### Inserting an SD Card

#### To insert an SD Card:

- 1 Open the fold out monitor to access the SD card slots. These are the smaller slots located between the CFast slots.
- 2 Set the storage media toggle switch above the slots to ‘SD’.
- 3 With the label on the SD card facing away from the touchscreen, insert the card until you feel it lock into place. To remove an SD card, push the SD card in to eject it.
- 4 The storage indicator at the bottom of the LCD touchscreen will show the name and record time remaining of detected cards.

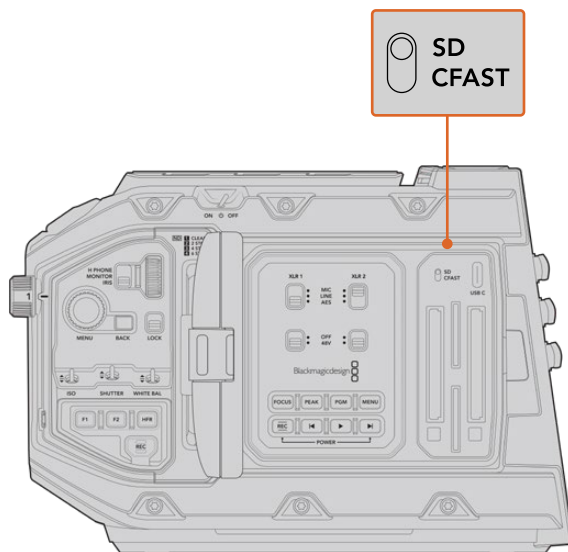

When recording to SD cards on URSA Mini Pro 4.6K make sure the storage media selection switch is set to 'SD'

### Choosing a fast SD Card

If you are recording Ultra HD on Blackmagic URSA Mini Pro, then we recommend using the fastest high speed UHS-II type SD cards available. It's important to use high speed UHS-II SD cards for Ultra HD and HD recording, or UHS-1 cards for HD recording. These cards are rated for fast data speeds and support larger storage sizes. Generally the faster the cards, the better. Refer to the recommended SD cards table earlier in this section for more information.

Before using your cards, you will need to format them to either HFS+ or exFAT formats. You can format your media with the storage manager or your computer. For more information, see the 'preparing media for recording' section.

If you want to, you can format your cards using a Mac or Windows computer. When using your media on Mac, you can use HFS+ which is the Mac disk format. If you are using Windows then you should use exFAT format, which is the Windows disk format that Mac computers can also read.

The tables below identify the SD cards recommended for use when shooting with Blackmagic URSA Mini Pro. It's worth regularly checking the latest version of this manual for more up to date information. Updated manuals are available for download from the Blackmagic Design website at [www.blackmagicdesign.com/support](http://www.blackmagicdesign.com/support)

**NOTE** When filming high frame rate or Ultra HD footage on your URSA Mini, we recommend CFast 2.0 or SD UHS-II recording media, which are typically faster and available in higher storage capacities than SD UHS-I media.

For the most up to date information about SD cards recommended for URSA Mini Pro 12K, please refer to the Blackmagic Design support center at [www.blackmagicdesign.com/support](http://www.blackmagicdesign.com/support).

### Which SD cards should I use with Blackmagic URSA Mini Pro 12K?

The following SD cards are recommended for recording 12K DCI Blackmagic RAW 12:1 up to 24 frames per second.

Brand	Card Name	Storage
ProGrade Digital	V90 UHS-II 300MB/s SDXC	64GB
ProGrade Digital	V90 UHS-II 300MB/s SDXC	128GB
ProGrade Digital	V90 UHS-II 300MB/s SDXC	256GB
Sony	Tough SF-G64 300MB/s UHS-II SDXC	64GB
Sony	Tough SF-G128 300MB/s UHS-II SDXC	128GB

The following SD cards are recommended for recording 8K DCI Blackmagic RAW 18:1 at up to 60 frames per second.

Brand	Card Name	Storage
Angelbird	AV Pro MK2 V90 SDXC	256GB
ProGrade Digital	V90 UHS-II 300MB/s SDXC	64GB
ProGrade Digital	V90 UHS-II 300MB/s SDXC	128GB
ProGrade Digital	V90 UHS-II 300MB/s SDXC	256GB
Sony	Tough SF-G64 300MB/s UHS-II SDXC	64GB
Sony	Tough SF-G128 300MB/s UHS-II SDXC	128GB
Wise	285MB/s UHS-II SDXC	64GB
Wise	285MB/s UHS-II SDXC	128GB

### Which SD cards should I use with URSA Mini Pro?

The following SD cards are recommended for recording 4K DCI Blackmagic RAW 12:1 up to 30 frames per second.

Brand	Card Name	Storage
Angelbird	AV Pro 300MB/s UHS-II SDXC	64GB
Angelbird	AV Pro 300MB/s UHS-II SDXC	128GB
Lexar	Professional 2000x UHS-II 300MB/s SDXC	64GB
Lexar	Professional 1000x UHS-II 150MB/s SDXC	64GB
SanDisk	Extreme Pro UHS-I 95MB/s SDXC	64GB
SanDisk	Extreme Pro UHS-I 95MB/s SDXC	128GB
SanDisk	Extreme Pro UHS-I 95MB/s SDXC	256GB
SanDisk	Extreme Pro UHS-I 95MB/s SDXC	512GB
SanDisk	Extreme Pro UHS-II 280MB/s SDXC	64GB
SanDisk	Extreme Pro UHS-II 300MB/s SDHC	32GB
SanDisk	Extreme Pro UHS-II 300MB/s SDXC	128GB

Brand	Card Name	Storage
Sony	SF-G64 300MB/s UHS-II SDXC	64GB
Sony	SF-G128 300MB/s UHS-II SDXC	128GB
Toshiba	Exceria Pro UHS-II 270MB/s SDXC	64GB
Toshiba	Exceria Pro UHS-II 270MB/s SDXC	128GB
Toshiba	Exceria Pro UHS-II N502 SDHC	32GB
Toshiba	Exceria Pro UHS-II N502 SDXC	64GB
Toshiba	Exceria Pro UHS-II N502 SDXC	128GB
Toshiba	Exceria Pro UHS-II N502 SDXC	256GB
Transcend	Ultimate UHS-II 180MB/s SDXC	64GB
Wise	285MB/s UHS-II SDXC	64GB
Wise	285MB/s UHS-II SDXC	128GB

The following SD cards are recommended for 2160p ProRes 422 HQ up to 30 frames per second.

Brand	Card Name	Storage
Angelbird	AV Pro 300MB/s UHS-II SDXC	64GB
Angelbird	AV Pro 300MB/s UHS-II SDXC	128GB
Delkin Devices	UHS-II 250MB/s SDHC	32GB
ProGrade Digital	V90 UHS-II 250MB/s SDXC	128GB
SanDisk	Extreme Pro UHS-II 280MB/s SDHC	32GB
SanDisk	Extreme Pro UHS-II 280MB/s SDXC	64GB
SanDisk	Extreme Pro UHS-II 300MB/s SDHC	32GB
SanDisk	Extreme Pro UHS-II 300MB/s SDXC	128GB
Sony	SF-G64 300MB/s UHS-II SDXC	64GB
Sony	SF-G128 300MB/s UHS-II SDXC	128GB
Toshiba	Exceria Pro UHS-II 270MB/s SDXC	64GB
Toshiba	Exceria Pro UHS-II N502 SDHC	32GB
Toshiba	Exceria Pro UHS-II N502 SDXC	64GB
Toshiba	Exceria Pro UHS-II N502 SDXC	128GB
Toshiba	Exceria Pro UHS-II N502 SDXC	256GB
Transcend	Ultimate UHS-II 180MB/s SDXC	64GB
Wise	285MB/s UHS-II SDXC	64GB
Wise	285MB/s UHS-II SDXC	128GB

The following SD cards are recommended for 1080p ProRes 422 HQ up to 60 frames per second.

<b>Brand</b>	<b>Card Name</b>	<b>Storage</b>
Angelbird	AV Pro 300MB/s UHS-II SDXC	64GB
Angelbird	AV Pro 300MB/s UHS-II SDXC	128GB
Delkin Devices	UHS-II 250MB/s SDHC	32GB
Lexar	Professional 2000x UHS-II 300MB/s SDHC	32GB
Lexar	Professional 2000x UHS-II 300MB/s SDXC	64GB
Lexar	Professional 1000x UHS-II 150MB/s SDXC	64GB
ProGrade Digital	V90 UHS-II 250MB/s SDXC	128GB
ProGrade Digital	V60 UHS-II 200MB/s SDXC	64GB
ProGrade Digital	V60 UHS-II 200MB/s SDXC	128GB
SanDisk	Extreme Pro UHS-I 95MB/s SDXC	64GB
SanDisk	Extreme Pro UHS-I 95MB/s SDXC	128GB
SanDisk	Extreme Pro UHS-I 95MB/s SDXC	256GB
SanDisk	Extreme Pro UHS-I 95MB/s SDXC	512GB
SanDisk	Extreme Pro UHS-II 280MB/s SDHC	32GB
SanDisk	Extreme Pro UHS-II 280MB/s SDXC	64GB
SanDisk	Extreme Pro UHS-II 300MB/s SDXC	64GB
SanDisk	Extreme Pro UHS-II 300MB/s SDXC	128GB
Sony	SF-G64 300MB/s UHS-II SDXC	64GB
Sony	SF-G128 300MB/s UHS-II SDXC	128GB
Toshiba	Exceria Pro UHS-II 270MB/s SDXC	64GB
Toshiba	Exceria Pro UHS-II 270MB/s SDXC	128GB
Toshiba	Exceria Pro UHS-II 270MB/s SDXC	256GB
Toshiba	Exceria Pro UHS-II N502 SDHC	32GB
Toshiba	Exceria Pro UHS-II N502 SDXC	64GB
Toshiba	Exceria Pro UHS-II N502 SDXC	128GB
Toshiba	Exceria Pro UHS-II N502 SDXC	256GB
Transcend	Ultimate UHS-II 180MB/s SDXC	64GB
Wise	285MB/s UHS-II SDXC	64GB
Wise	285MB/s UHS-II SDXC	128GB

For the most up to date information on supported SD cards for URSA Mini Pro please refer to the Blackmagic Design support center at [www.blackmagicdesign.com/support](http://www.blackmagicdesign.com/support).



## Locking and Unlocking SD Cards

SD cards can be write protected, or 'locked', to prevent data from being overwritten.

When inserting an SD card, make sure the card is not write protected. Write protection is disabled by moving the plastic switch on the left side of the card to the position closest to the connectors. After recording, you can then write protect the card by sliding the switch back down to the bottom position.



Move the lock tab up or down to lock or unlock an SD card

Your URSA Mini Pro will let you know if you've inserted a locked SD card by displaying a 'locked' icon on the LCD touchscreen and storage menu. If the card is locked, you won't be able to record video, capture stills, or export LUTs and presets until it is unlocked.

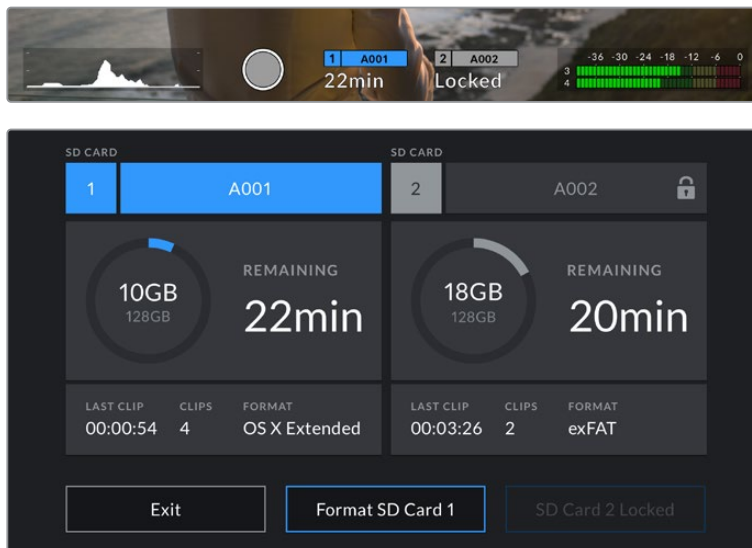

Your URSA Mini Pro will indicate when locked SD storage media is inserted

## USB-C flash disks

Blackmagic URSA Mini Pro 4.6K G2 features a high speed USB-C expansion port, which allows you to record video directly to USB-C flash disks. URSA Mini Pro 12K has two USB-C ports. The USB C 3.1 Gen 1 port on the side near the CFast card slots is for software updates. The port on the rear panel near the SDI connectors is for recording to high speed SSDs via USB-C 3.1 Gen 2. These fast, high capacity drives allow you to record video for long periods, which can be important when filming events with long durations.

When a USB-C flash disk is connected to your camera, it occupies the second media slot in your camera's operating system. Tapping the card or drive name in the storage menu sets it as the active drive. This means that recording, playback and storage management is exactly the same for USB-C flash disks as it is for CFast, SD cards and SSDs.

Once you have finished recording you can connect the same drive directly to your computer for editing and post production, without having to copy media across.

**To connect a USB-C flash disk:**

- 1 Connect one end of a USB type-C cable to your USB-C flash disk.
- 2 On URSA Mini Pro 12K, plug the USB-C cable into the USB-C port on the back panel below the SDI ports. On URSA Mini Pro 4.6K G2, open the fold out touchscreen on the left side of the camera and connect the cable to the USB-C port above the CFast slots.

**Which USB-C flash disks should I use with Blackmagic URSA Mini Pro 12K?**

The following USB-C flash disks are recommended for recording 12K DCI Blackmagic RAW 8:1 at up to 30 frames per second.

Brand	USB-C Flash Disk Name	Storage
Angelbird	SSD2GO PKT MK2	512GB
Angelbird	SSD2GO PKT MK2	2TB
Glyph	Atom Raid SSD	4TB
Sony	Tough SL-CG5	500GB
Sony	Tough SL-C1	1TB
Sony	Tough SL-C2	2TB
Delkin Devices	Juggler	2TB
Wise	PTS-512 Portable SSD	512GB
Wise	PTS-1024 Portable SSD	1TB
Wise	PTS-2048 Portable SSD	2TB

**Which USB-C flash disks should I use with Blackmagic URSA Mini Pro 4.6K G2?**

The following USB-C flash disks are recommended for 4.6K Blackmagic RAW 3:1 up to 60 frames per second.

Brand	USB-C Flash Disk Name	Storage
Samsung	Portable SSD T5	500GB
Samsung	Portable SSD T5	1TB
Wise	Portable SSD	256GB
Wise	Portable SSD	512GB
Wise	Portable SSD	1TB

For the most up to date list of recommended USB-C flash disks please go to [www.blackmagicdesign.com/support](http://www.blackmagicdesign.com/support).

## Important Notes About USB-C flash disk Speed

Some models of USB-C flash disk can't save video data at the speed the manufacturer claims. This is due to the disk using hidden data compression to attain higher write speeds. This data compression can only save data at the manufacturer's claimed speed when storing data such as blank data or simple files. Video data includes video noise and pixels which are more random so compression will not help, therefore revealing the true speed of the disk.

Some USB-C flash disks can have as much as 50% less write speed than the manufacturer's claimed speed. So even though the disk specifications claim a USB-C flash disk has speeds fast enough to handle video, in reality the disk isn't fast enough for real time video capture.

Use Blackmagic Disk Speed Test to accurately measure whether your USB-C flash disk will be able to handle high data rate video capture and playback. Blackmagic Disk Speed Test uses data to simulate the storage of video so you get results similar to what you'll see when capturing video to a disk. During Blackmagic testing, we have found newer, larger models of USB-C flash disk and larger capacity USB-C flash disks are generally faster.

Blackmagic Disk Speed Test is available from the Mac app store. Windows and Mac versions are also included in Blackmagic Desktop Video, which you can download from the 'capture and playback' section of the Blackmagic Design support center at [www.blackmagicdesign.com/support](http://www.blackmagicdesign.com/support).

## SSDs

With the optional URSA Mini Recorder, you can record video directly to solid state drives, or 'SSDs'. These fast, high capacity drives can be readily available from a variety of consumer electronics outlets.

URSA Mini Recorder features a USB-C port enabling high speeds to work with standard 2.5" SATA SSD's as well as 7mm U.2 SSD's while M.2 solid state drives will work when using an M.2 to U.2 adapter. To reach the proper speeds available, a certified USB 3.1 Gen 2 cable is required. The supplied USB-C cable features locking connectors at each end to maintain a secure connection during use.

**NOTE** See the section 'Blackmagic URSA Mini Recorder' in this manual for information on installing Blackmagic URSA Mini Recorder.

### Inserting an SSD

#### To insert an SSD:

- 1 Hold your SSD with the connection pins facing towards the front of your camera.
- 2 Open the spring loaded cover on URSA Mini Recorder and gently insert the SSD into the slot.

**TIP** URSA Mini Recorder has a pressure plate to keep different sized SSDs in place, so there's no need to use spacers to fit your drive.

- 3 Once your SSD is all the way into the slot gently push it home until you feel it register, then lower URSA Mini Recorder's cover.

### To remove an SSD:

Open URSA Mini Recorder's cover and gently grasp the drive between your thumb and forefinger. There's a small recess in the top of the bay to let you get a grip on the drive. Simply pull the drive out and close the cover.

**NOTE** Blackmagic URSA Mini Recorder occupies the second storage slot in URSA Mini's operating system. This means that, while URSA Mini Recorder is connected and a compatible SSD is inserted, your camera's second CFast 2.0 and SD card slot will be unavailable.

To use these slots instead, disconnect the Mini Recorder USB-C connection from URSA Mini Pro 12K. There is no need to remove the Mini Recorder itself from your camera. For more information, see the section 'Blackmagic URSA Mini Recorder' in this manual.

### Choosing a fast SSD for URSA Mini Recorder

SSDs are designed to offer fast, affordable storage for a wide range of devices it's important to note that film making is only one part of the SSD market though, so choosing the right drive is vital to ensuring that you have enough bandwidth to record 12K Blackmagic RAW or Ultra HD footage. Many SSDs are designed for home computing and aren't fast enough to record Ultra HD video.

We highly recommend using only the SSDs from our recommended list, which have been tested with Blackmagic URSA Mini Pro 12K to ensure support for continuous filming at the specified resolutions. For the most up to date list of recommended SSDs please go to [www.blackmagicdesign.com/support](http://www.blackmagicdesign.com/support).

#### Blackmagic URSA Mini Recorder U.2 Drives

The following U.2 2.5" SSD's are recommended for recording 12K DCI Blackmagic RAW 8:1 at up to 50 frames per second.

Brand	Model	Storage
Samsung	983 DCT U.2 MZ-QLB960NE	960GB
Samsung	983 DCT U.2 MZ-QLB1T9NE	1.92TB

#### Blackmagic URSA Mini Recorder M.2 Drives

The following M.2 SSD's with a M.2 to U.2 adapter are recommended for recording 12K DCI Blackmagic RAW 8:1 at up to 30 frames per second.

Brand	Model	Storage
SanDisk	Extreme Pro M.2 NVMe 3D SSD	500GB
Western Digital	WD Black NVMe SSD WDS500G2X0C	500GB
Western Digital	WD Black SN750 NVMe SSD WDS100T3X0C	1TB

## Important Notes About SSD Speed

Some models of SSD can't save video data at the speed the manufacturer claims. This is due to the disk using hidden data compression to attain higher write speeds. This data compression can only save data at the manufacturer's claimed speed when storing data such as blank data or simple files. Video data includes video noise and pixels which are more random so compression will not help, therefore revealing the true speed of the disk.

Some SSDs can have up to 50% lower write speed than the manufacturer's claimed speed. So even though the disk specifications claim an SSD has speeds fast enough to handle video, in reality the disk isn't fast enough when used to store video data for real time capture.

Use Blackmagic Disk Speed Test to accurately measure whether your SSD will be able to handle high data rate video capture and playback. Blackmagic Disk Speed Test uses data to simulate the storage of video so you get results similar to what you'll see when capturing video to a disk. During Blackmagic testing, we have found newer, larger models of SSD and larger capacity SSDs are generally faster.

## Preparing Media for Recording

You can format your CFast cards, SD cards or SSDs using the storage manager, or via a Mac or Windows computer. We recommend formatting storage media using URSA Mini for best performance.

HFS+ is also known as OS X Extended and is the recommended format as it supports 'journaling'. Data on journaled media is more likely to be recovered in the rare event that your storage media becomes corrupted. HFS+ is natively supported by Mac. exFAT is supported natively by Mac and Windows without needing to purchase any additional software. However, exFAT does not support journaling.

**NOTE** Before formatting your media, it's important to make sure the media storage switch has been set correctly to either SD card or CFast card. Always check the settings carefully before formatting.

## Preparing Media on Blackmagic URSA Mini

- 1 Tap either storage indicator at the bottom of the LCD touchscreen to enter the storage manager.
- 2 Tap a format button at the bottom of the touchscreen to format the card in slot 1 or 2, respectively. If you plug a flash disk into the USB-C port of an URSA Mini Pro G2, the button to format the second drive is 'Format drive'.



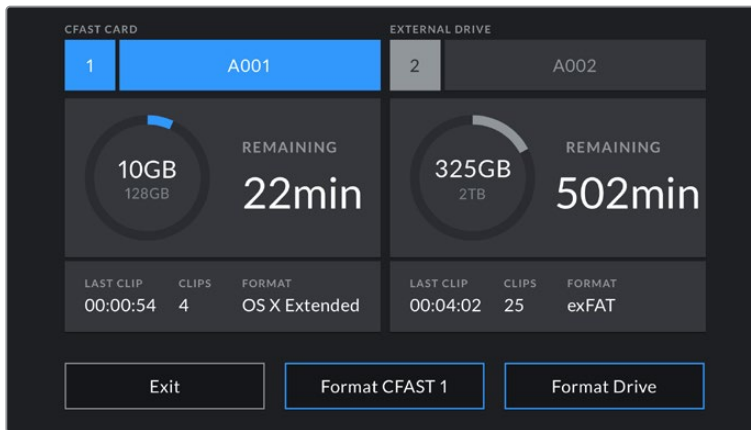

Use your URSA Mini's storage manager to format your camera's storage media

- 3 Tap 'edit reel number' if you would like to manually change the reel number.
- 4 Choose OS X Extended or exFAT format and tap the format button.

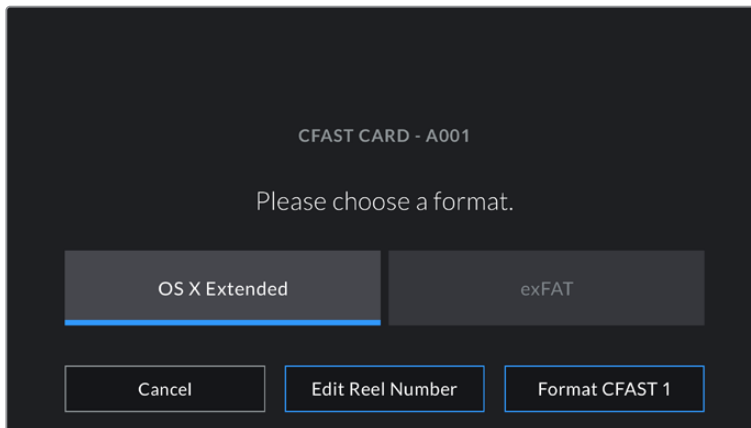

Tap 'edit reel number' to manually edit the reel number

- 5 You will be asked to confirm your selection. Tap the format button again to continue or 'cancel' to cancel the format.

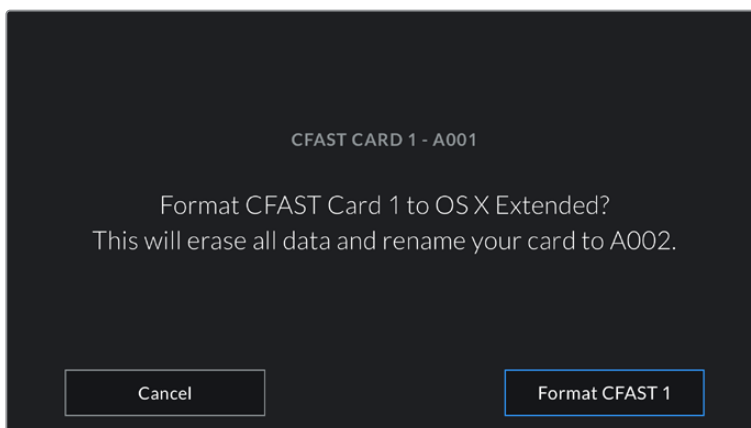

Check that you have selected the correct card before formatting

- 6 You will be notified when the format is complete.
- 7 Tap 'ok' to return to the storage manager.
- 8 Tap 'exit' to leave the storage manager.

When formatting CFast cards, SD cards or SSDs using the storage manager, your URSA Mini will use the Camera ID from the slate and reel number to name the card. Your URSA Mini automatically increments reel numbers each time you format. If you need to manually enter a specific reel number, tap the 'edit reel number' and enter the number you want to format the card as.

When you start a new project, reel numbering will reset to 1 when you tap on 'reset project data' in the 'project' tab of the slate.

When URSA Mini Recorder is connected and an SSD is loaded, the recorder takes over from URSA Mini's number '2' storage slot and you'll see an 'SSD' indicator over slot 2 on your camera's storage manager.

## Preparing Media on Blackmagic URSA Mini Pro

The process for preparing storage media on your URSA Mini Pro is exactly the same as the URSA Mini process outlined above. The only difference is the added option to format SD cards in addition to CFast cards, SSDs, and USB-C flash disks on URSA Mini Pro 12K and URSA Mini Pro 4.6K G2. It's worth mentioning that if your camera's media storage switch is set to SD or CFast, only the selected card type will be formatted when you tap 'format card'. When using URSA Mini Recorder or a USB-C flash disk with URSA Mini Pro 12K or URSA Mini Pro 4.6K G2, the SSD will appear in slot 2 regardless of the position of the media storage switch.



The storage manager on your camera will indicate whether you are currently managing CFast, SD, SSD or USB-C flash disk media

**TIP** If your URSA Mini Pro is set to record to SD cards and you have inserted a locked card, you will be unable to format that card. A padlock icon will appear next to the card's name in the storage manager. Simply unlock the card to format and record. For more information on locking SD cards, see the 'SD cards' section of this manual.

When formatting storage media on your URSA Mini Pro you will be prompted to hold the 'format' button for 3 seconds. The camera will notify you once formatting is complete.

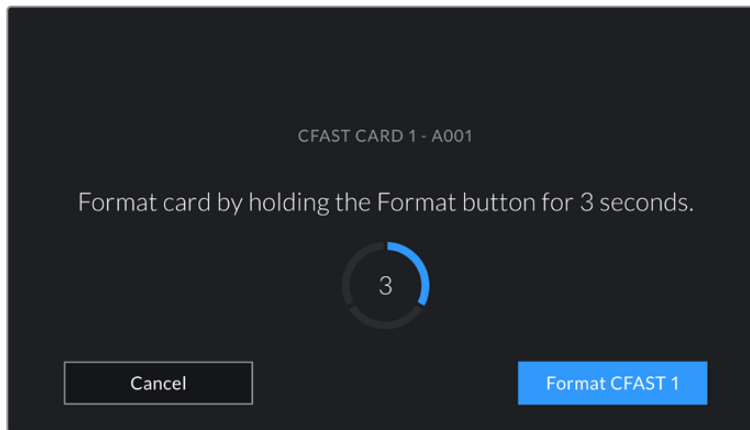

Hold the format button for 3 seconds to begin formatting your media

For information on switching between CFast and SD storage see the 'SD Cards' section earlier in this manual.

**NOTE** If you have the optional URSA Mini Recorder connected, 'SSD recorder' will appear over storage slot 2. When a USB-C flash disk is connected, 'External Drive' will appear.

## Preparing Media on Mac

Use the Disk Utility application included with Mac to format your CFast card, SD card, or SSD in the HFS+ or exFAT formats. Remember to back up anything important from your media first as all data will be lost when it is formatted.

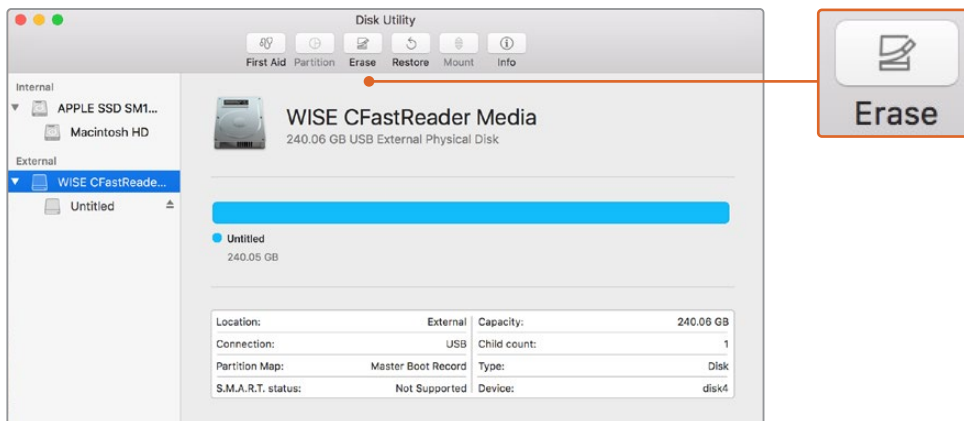

Use Disk Utility on Mac to erase your camera's storage media in the Mac OS extended (journaled) or exFAT format

- 1 Connect the storage media to your computer using a SD card reader, dock or adapter, and dismiss any message offering to use your media for Time Machine backups.
- 2 Go to applications/utilities and launch Disk Utility.
- 3 Click on the disk icon for your camera's storage media and then click the 'erase' tab.

- 4 Set the 'format' to 'Mac OS extended (journaled)' or 'exFAT'.
- 5 Type a 'name' for the new volume and then click 'erase'. Your camera's storage media will quickly be formatted and made ready for use.

## Preparing Media on Windows

The 'format' dialog box can format your camera's storage media in the exFAT format on a Windows PC. Remember to back up anything important from your media first as all data will be lost when it is formatted.

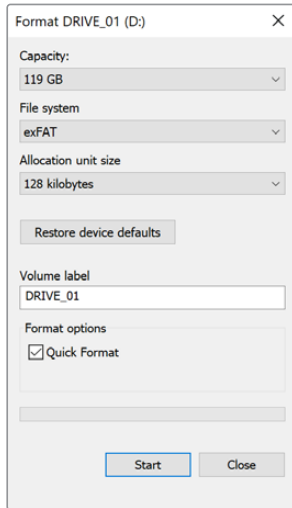

Use the 'format' dialog box feature in Windows to format your camera's storage media in the exFAT format

- 1 Connect your camera's storage media to your computer using an external reader/writer or SSD dock or adapter.
- 2 Open the 'start' menu or 'start' screen and choose 'computer'. Right click on your camera's storage media.
- 3 From the contextual menu, choose 'format'.
- 4 Set the file system to 'exFAT' and the allocation unit size to 128 kilobytes.
- 5 Type a volume label, select 'quick format' and click 'start'.
- 6 Your storage media will quickly be formatted and made ready for use.

**NOTE** If your recordings are dropping frames, check that your card or drive is on our list of recommended media for the codec and frame size you are using. For lower data rates try lowering your frame rate, resolution, or try a compressed codec such as ProRes. Check the Blackmagic Design website for the latest information at [www.blackmagicdesign.com](http://www.blackmagicdesign.com)

# Recording

## Recording Clips

On Blackmagic URSA Mini you can start recording by pressing the red 'record' button on the inside control panel, the outside of the fold out monitor, the touchscreen or the optional Blackmagic URSA Handgrip. On Blackmagic URSA Mini Pro, the external 'record' button is located in the forward control panel for convenient access when shooting from the shoulder. Press the 'record' button again to stop recording.

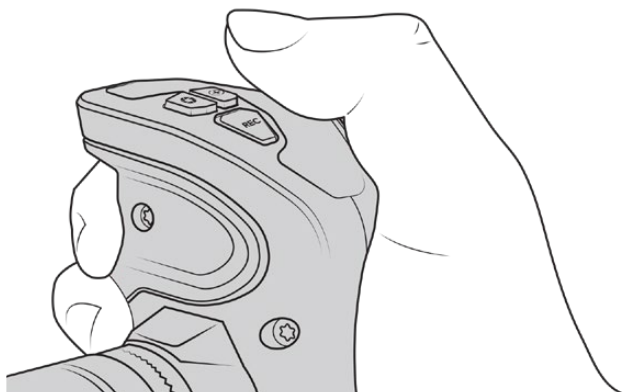

You can also record clips by pressing the 'record' button marked REC on the optional Blackmagic URSA Handgrip

Another option for starting and stopping record is to attach an external LANC controller to your URSA Mini's LANC input and trigger the record externally. For example, you may want to attach a LANC controller to your tripod so you can trigger the recording without taking your hands off the focus ring and tripod handle.

**NOTE** If you toggle the 'storage media selection' switch mid-recording, the camera will complete the current recording before switching to the other type of media. This ensures that you can not damage your recording if the switch is adjusted during a take.

## Choosing the Codec, Resolution and Sensor Area

Your Blackmagic URSA Mini Pro can record using Blackmagic RAW, using either a constant quality or constant bitrate setting. URSA Mini Pro and URSA Mini can also record Apple ProRes compressed codecs. Sensor frame rate options will vary depending on your camera, the codec and resolution you choose.

It's worth noting that clips recorded using Blackmagic RAW are compatible with DaVinci Resolve, Blackmagic RAW Player and other applications that support Blackmagic RAW SDK. Blackmagic RAW has already been adopted by many post production platforms. It may not be supported natively in all editing software but most work with the plugins provided in our Camera Update and Blackmagic RAW installer. For more information, see the 'Working with Third Party Software' section.



## Dynamic Range

Blackmagic URSA Mini Pro 12K produces incredible, wide dynamic range images with 14 stops of latitude. URSA Mini Pro G2, URSA Mini Pro and URSA Mini 4.6K have 15 stops of dynamic range.

This maximizes the information in your video signal to help you get the most out of color grading software, such as DaVinci Resolve.

The wide dynamic range captured is also perfect for high dynamic range or HDR content delivery.

As the charts below indicate, the 14 stops of dynamic range are available across the entire ISO range from ISO 125 to 3200 for URSA Mini Pro 12K, and 15 stops of dynamic range from ISO 200 to 3200 for URSA Mini 4.6K, URSA Mini Pro and URSA Mini Pro G2.

The distribution of these stops above and below middle gray will vary depending on the ISO selected. For example, on URSA Mini Pro G2 at ISO 200 there will be 10.8 stops allocated to the shadow areas of the image, with the remaining 3.9 stops allocated to the highlights in the image.

### Blackmagic URSA Mini Pro 12K Dynamic Range

ISO	125	160	200	250	320	400	500	640	800	1000	1250	1600	2000	2500	3200
Total Stops	13.9	13.9	13.9	13.9	13.9	13.9	13.9	13.9	13.9	13.9	13.9	13.9	13.9	13.9	13.9

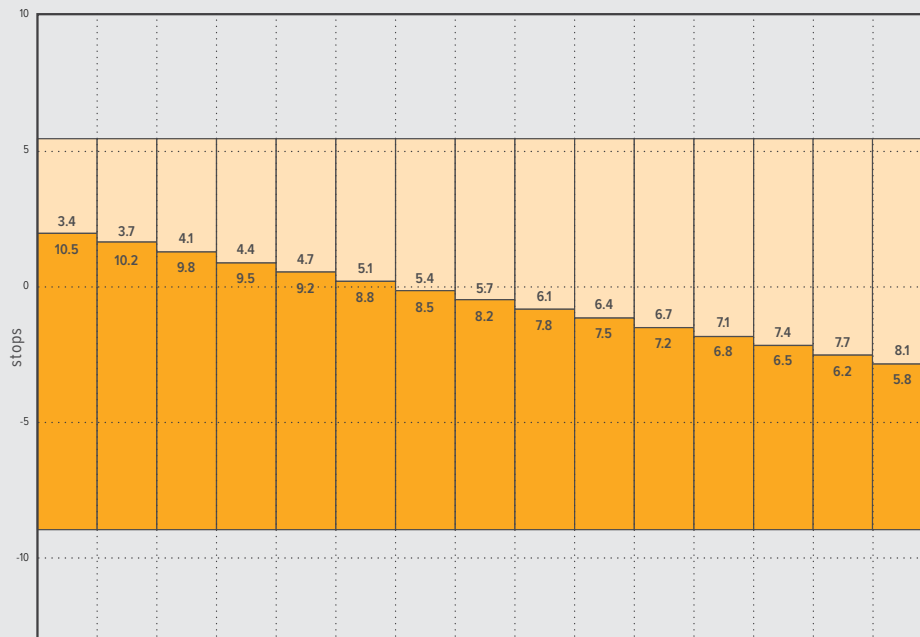

Stops Above  
 Stops Below

## Blackmagic URSA Mini 4.6K, URSA Mini Pro and URSA Mini Pro G2 Dynamic Range

ISO	200	250	320	400	500	640	800	1000	1250	1600	2000	2500	3200
Total Stops	14.7	14.7	14.7	14.7	14.7	14.7	14.7	14.7	14.7	14.7	14.7	14.7	14.7

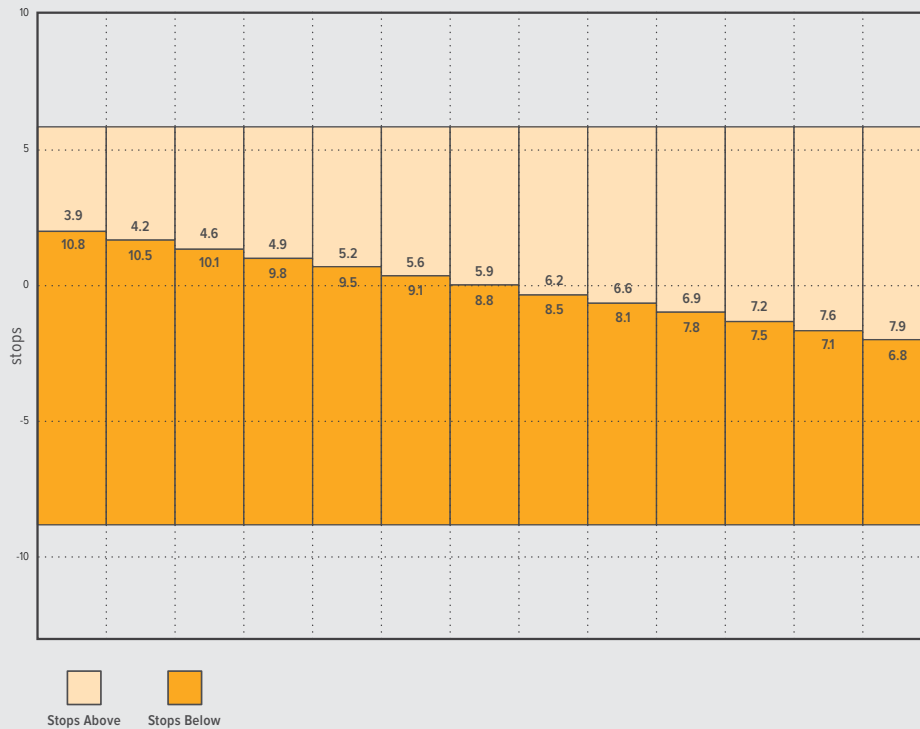

## Blackmagic RAW

Blackmagic URSA Mini Pro supports the new Blackmagic RAW file format. This format offers superior image quality, wide dynamic range and a broad selection of compression ratios. Blackmagic RAW keeps all the benefits of RAW recording, but the files are very fast because part of the demosaic performed in the camera where it can be hardware accelerated.

The Blackmagic RAW format is also intelligent because it understands the image sensor in the camera. This means you get much better quality for a smaller file format. Smaller files that are higher quality means Blackmagic RAW is a good alternative to other video and RAW file formats.

Blackmagic RAW also includes powerful metadata support so the software reading the files knows your camera settings. If you like shooting in video gamma because you need to turn around edits quickly and you don't have time for color correction, then this metadata feature means you can select video gamma, shoot in video gamma, and the file will display with video gamma applied when you open it in software. However underneath, the file is actually film gamma and the metadata in the file is what's telling the software to apply the video gamma.

So what all this means is if you want to color grade your images at some point, then you have all that film dynamic range preserved in the file. You don't have your images hard clipped in the whites or the blacks, so you retain detail and you can color grade to make all your images look cinematic. However, if you don't have time for color grading, that's fine because your images will have the video gamma applied and look like normal video camera images. You are not locked in on the shoot and you can change your mind later during post production.

Blackmagic RAW files are extremely fast and the codec is optimized for your computer's CPU and GPU. This means it has fast smooth playback and eliminates the need for hardware decoder boards, which is important for laptop use. Software that reads Blackmagic RAW also gets the advantage of processing via Apple Metal, Nvidia CUDA and OpenCL.

This means that Blackmagic RAW plays back at normal speed like a video file on most computers, without needing to cache it first or lower the resolution.

It's also worth mentioning that lens information is recorded in the metadata on a frame by frame basis. For example, when using compatible lenses, any zoom or focus changes performed over the length of a clip will be saved, frame by frame, to the metadata in the Blackmagic RAW file.

## Recording to Blackmagic RAW

Blackmagic RAW works in two different ways. You have a choice to use either the constant bitrate codec, or the constant quality codec.

The constant bitrate codec works in a similar way to most codecs. It tries to keep the data rate at a consistent level and won't let the data rate go too high. This means even if you are shooting a complex image that might need a bit more data to store the image, a constant bitrate codec will just compress the image harder to make sure the images fit within the space allocated.

This can be fine for video codecs, however when shooting RAW you really want to ensure the quality is predictable. What would happen if the images you were shooting needed more data, but the codec just compresses harder to make a specified data rate? It's possible you could lose quality, but not be sure it's happening until you return from a shoot.

To solve this problem, Blackmagic RAW also has an alternative codec choice called constant quality. This codec is technically called a variable bitrate codec, but what it's really doing is allowing the size of the file to grow if your images need extra data. There is no upper limit on the file size if you need to encode an image but maintain quality.

So Blackmagic RAW set to the constant quality setting will just let the file grow as big as it needs to be to encode your images. It also means the files could be larger or smaller depending on what you are shooting. I guess if you leave your lens cap on the lens, you won't waste space on your media!

It is also worth noting that the quality settings for Blackmagic RAW are not obscure names, but are more meaningful as they are derived from what's happening technically. So for example when you have selected the constant bitrate codec, you will see quality settings of 3:1, 5:1, 8:1, 12:1 or 18:1 depending on the type of your URSA Mini Pro camera. These are the ratios of the uncompressed RAW file size vs the file sizes you should expect when shooting in Blackmagic RAW. 3:1 is better quality as the file is larger, while 18:1 is the smallest file size with the lowest quality. Many users of Blackmagic RAW find that 12:1 or 18:1 has been perfectly ok and they have not seen any quality limitations. However it's best to experiment and try various settings for yourself.

When using Blackmagic RAW in constant quality you will see the settings are Q0, Q1, Q3 or Q5 depending on the type of your URSA Mini Pro camera. These are the compression parameters passed to the codec and they are setting how much compression is applied in a more technical way. This setting is different because the codec operates differently between constant bitrate vs constant quality. In this constant quality setting, you really cannot tell what the file size ratio will become as it varies a lot based on what you are shooting. So in this case the setting is different and the file will become the size needed to store your media.

## Constant Bitrate Settings

The names for 3:1, 5:1, 8:1, 12:1 and 18:1 represent the compression ratio. For example, 12:1 compression produces a file size roughly 12 times smaller than uncompressed RAW.

Blackmagic RAW constant bitrate is available on URSA Mini Pro 12K at 5:1, 8:1, 12:1 and 18:1. URSA Mini Pro 4.6K G2 and URSA Mini Pro 4.6K support Blackmagic RAW constant bitrate at 3:1, 5:1, 8:1 and 12:1.

## Constant Quality Settings

Q0, Q1, Q3 and Q5 refer to different levels of quantization. Q5 has a greater level of quantization but offers a greatly improved data rate. As mentioned above, the constant quality setting can result in files that grow and shrink quite a lot, depending on what you are shooting. This also means it's possible to shoot something and see the file size increase to beyond what your media card can keep up with. It could result in dropped frames. However the benefit is that you can instantly see if this happens on a shoot and then investigate your settings vs quality.

Blackmagic RAW constant quality is available on URSA Mini Pro 12K at Q0, Q1, Q3 and Q5. URSA Mini Pro 4.6K G2 and URSA Mini Pro 4.6K support Blackmagic RAW constant quality at Q0 and Q5.

## Blackmagic RAW Player

The Blackmagic RAW player included in your Blackmagic camera's software installer is a streamlined application for reviewing clips. Simply double click on a Blackmagic RAW file to open it, and you can quickly play and scroll through the file with its full resolution and bit depth.

When decoding frames, the CPU acceleration in the SDK library supports all main architectures, and also supports GPU acceleration via Apple Metal, Nvidia CUDA and OpenCL. It also works with the Blackmagic eGPU for extra performance. Blackmagic RAW player is available for Mac, Windows and Linux.

## Sidecar Files

Blackmagic RAW sidecar files let you override metadata in a file without overwriting embedded metadata in the original file. This metadata includes the RAW settings as well as information on iris, focus, focal length, white balance, tint, color space, project name, take number and more. Metadata is encoded frame by frame over the duration of the clip, which is important for lens data if the lens is adjusted during a shot. You can add or edit metadata in sidecar files with DaVinci Resolve or even a text editor because it's a human readable format.

Sidecar files can be used to automatically add new RAW settings to a playback simply by moving the sidecar file into the same folder as the corresponding RAW file. If you move the sidecar file out of the folder and reopen the Blackmagic RAW file, the RAW settings are not applied and you see the file as it was originally shot. Any software that uses the Blackmagic RAW SDK can access these settings. Changes made are saved in the sidecar file and can then be seen by Blackmagic RAW Player or any other software capable of reading Blackmagic RAW files.

When shooting video gamma, the file stays in film gamma, and the metadata tells the Blackmagic RAW processing to display using video gamma. Video gamma is great when you don't want to grade the image and want to deliver content quickly, however if you want to pull up the black parts of the image, or pull down the white areas, all the detail is retained. You never clip the video and all the detail is still there if you want to access it at any time.

## Blackmagic RAW in DaVinci Resolve

Settings can be adjusted for each Blackmagic RAW file, and then saved as a new sidecar file from the RAW tab in DaVinci Resolve for creative effect or optimized viewing. This also means you can copy your media for another DaVinci Resolve artist and they will have access to your modified gamma settings automatically on import. In addition to the other metadata your camera files contain, DaVinci Resolve can read your selected dynamic range, so your clips will automatically display in DaVinci Resolve with 'film', 'extended video' or 'video' dynamic range.

You can then customize these settings by adjusting the saturation, contrast and midpoint, as well as the highlight and shadow rolloff. Any adjustments can then be saved as a sidecar file, so the changes can be seen by anyone else working with the files in post. You can always return to the original camera metadata at any time.

You can also export a single Blackmagic RAW frame from the RAW tab in DaVinci Resolve, which contains all adjustments, metadata, full resolution and color information so it is easy to share a single frame grab or reference file with others.

For more information on how to use Blackmagic RAW in DaVinci Resolve, see the 'Using DaVinci Resolve' chapter in this manual.

## Blackmagic RAW Software Development Kit

The Blackmagic RAW Software Development Kit is an API developed by Blackmagic Design. You can use the Blackmagic RAW SDK to write your own applications to use the Blackmagic RAW format. This SDK library can be used by any developer to add support for reading, editing, and saving Blackmagic RAW files. The Blackmagic RAW SDK includes all the generation 4 and generation 5 color science so you can achieve organic cinematic images across any app that supports it. The Blackmagic RAW SDK supports Mac, Windows and Linux, and is available as a free download from the developer page of the Blackmagic website at [www.blackmagicdesign.com/developer](http://www.blackmagicdesign.com/developer)

The following diagram illustrates the components of the Blackmagic RAW API:

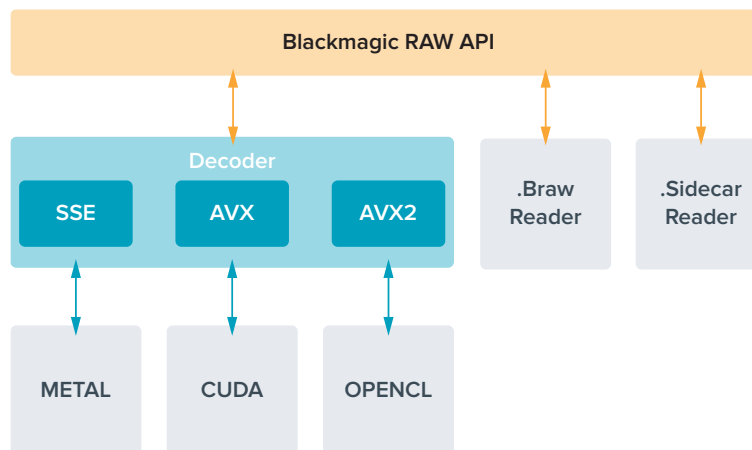

## Choosing Frame Rates

Your camera is able to shoot video using many different frame rates and you may be wondering which is the best one to use. Your camera's sensor frame rate can also have a big impact on the 'look' of footage. Generally, when selecting a sensor frame rate, there are some common items to consider. For many years, there have been presentation standards for film and television. These have set frame rates that differ between countries, but all share the same purpose; to display an efficient number of frames every second that portrays pleasing and convincing motion.

Cinema, for example, uses a standard 24 frames per second and while there have been recent experiments with faster frame rates, 24 frames per second remains widely accepted for international audiences. Television frame rates have generally conformed to technical broadcast standards for each country. For example, if you were making television content you would typically record using 29.97 frames per second for North American distribution, and 25 frames per second for Europe.

However, as technology has improved, today we have more choices and broadcast standards are changing. It is now common for sporting events to be recorded and broadcasted at higher frame rates. For example, some sporting events are recorded and broadcasted at up to 59.94 frames per second in North America, and 50 frames per second in Europe. This provides smoother motion on fast action and appears more lifelike. Alternatively, streaming and online broadcasters normally use frame rates similar to television, however there is more freedom to experiment due to user selectable viewing formats, and being limited only to what the audience's screens are capable of displaying.

Generally, when choosing a frame rate for a project, let your delivery format guide your choice. Your camera's project frame rate should be set to this, and your sensor frame should be set to 'match'. This means your clips will play back at the same speed the event happened in real life. If you are looking to create an interesting effect, for example slow motion, then you can set the sensor frame rate to a higher setting. The higher the sensor frame rate compared to the project frame rate, the slower the playback speed. For example, URSA Mini Pro G2 allows you to shoot at very high sensor frame rates for extreme slow motion.

For more information on using off speed sensor frame rates to achieve creative effects, refer to the 'touchscreen controls' section.

## Shooting at High Frame Rates

When shooting at high frame rates, your camera captures an increased number of frames per second when compared with the traditional sync speed frame rates of 24, 25 and 30 frames per second. This means that the image sensor has less time to collect light for each frame it captures and the resulting image from your camera will be darker.

So for example, if you switch from 25 to 50 frames per second, the amount of light reaching the sensor will be halved. To maintain your exposure you need to compensate for this change by opening up your lens an extra stop, by opening up your shutter angle from 180° to 360° or by adding some extra lighting to the scene that you are shooting.

When shooting at 120 frames per second you have 5 times less light so you may need to adjust multiple things such as lens aperture, shutter angle and lighting to achieve the same level of exposure.

Another thing to be mindful of when shooting at higher frame rates, is the fact that electronic light sources can add flicker to your recorded image. Specifically, when shooting at frame rates above 100 frames per second in a 50Hz environment or 120 frames per second in a 60Hz environment, artificial tungsten, fluorescent and LED light sources may introduce some flicker to your images. You may not see these flicker issues when previewing the scene on your LCD and

SDI feed or while recording, so it's important to perform a test shoot with the lights you plan to use and to play the clip back to check for flicker.

Your shutter setting can also affect the visibility of flicker when shooting under lights, so your URSA Mini can automatically calculate and display flicker free shutter options for your current frame rate. Note that the characteristics of individual light sources may still cause flicker even when using flicker free values. For more information, refer to the 'touchscreen controls' section.

If you have opened up your shutter to the slowest shutter speed or widest shutter angle possible and are still seeing flicker in recorded footage, you may need to consider using different light sources for your scene or look into using a faster lens.

## Maximum Frame Rates

The tables below contain available codecs, resolutions and their maximum sensor frame rates for URSA Mini 4.6K and URSA Mini Pro models. It should be noted that the references to Blackmagic RAW, ProRes 444 and ProRes 422 are references to all of the supported variants within each particular codec.

Because of the data rates required for recording high resolutions in slow motion you will need to choose a fast CFast card, USB-C flash disk or SSD. Refer to the 'storage media' section for recommended media for continuous high speed recording.

**TIP** You can test the speed your card can sustain by switching on the 'stop rec if card drops frames' feature and recording a test clip. This will allow you to test how long you can shoot at a particular frame rate in any given resolution. If the card stops recording too quickly then moving down to the next available compression setting or resolution will lower the data rate and make it easier for the card to maintain.

### Maximum Frame Rates for URSA Mini Pro 12K

Format		Resolution	Codec	Sensor scan	Max Frame Rate
12K	17:9	12288 x 6480	Blackmagic RAW	Full	60
	16:9	11520 x 6480	Blackmagic RAW	Full height	60
	2.4:1	12288 x 5112	Blackmagic RAW	Full width	75
	6:5 Anamorphic	7680 x 6408	Blackmagic RAW	Full height	60
8K	17:9	8192 x 4320	Blackmagic RAW	Full	120
	16:9	7680 x 4320	Blackmagic RAW	Full height	120
	2.4:1	8192 x 3408	Blackmagic RAW	Full width	160
	6:5 Anamorphic	5120 x 4272	Blackmagic RAW	Full height	120
6K	Super 16	6144 x 3240	Blackmagic RAW	Window	120
4K	DCI	4096 x 2160	Blackmagic RAW	Full	120
	16:9	3840 x 2160	Blackmagic RAW	Full height	120
	2.4:1	4096 x 1704	Blackmagic RAW	Full width	160
	6:5 Anamorphic	2560 x 2136	Blackmagic RAW	Full height	120
	Super 16	4096 x 2160	Blackmagic RAW	Window	240



**Maximum Frame Rates for URSA Mini Pro 4.6K G2, URSA Mini Pro 4.6K and URSA Mini 4.6K**

Format	Resolution	Codec	URSA Mini Pro 4.6K G2		URSA Mini Pro 4.6K		URSA Mini 4.6K	
			Sensor scan	Max Frame Rate	Sensor scan	Max Frame Rate	Sensor scan	Max Frame Rate
4.6K	4608 x 2592	Blackmagic RAW	Full	120	Full	60	–	–
		ProRes 444	Full	40	Full	30	Full	30
		ProRes 422	Full	80	Full	40	Full	40
4.6K 2.4:1	4608 x 1920	Blackmagic RAW	Window	150	Window	60	–	–
		ProRes 444	Window	60	Window	40	Window	40
		ProRes 422	Window	120	Window	50	Window	50
4K 16:9	4096 x 2304	Blackmagic RAW	Window	120	Window	60	–	–
		ProRes 444	Window	60	Full or Window	30	Full or Window	30
		ProRes 422	Window	100	Full or Window	50	Full or Window	50
4K DCI	4096 x 2160	Blackmagic RAW	Window	150	Window	60	–	–
		ProRes 444	Window	60	Full or Window	40	Full or Window	40
		ProRes 422	Window	120	Full or Window	50	Full or Window	50
UHD	3840 x 2160	Blackmagic RAW	Window	150	Window	60	–	–
		ProRes 444	Full or Window	60	Full or Window	40	Full or Window	40
		ProRes 422	Full or Window	120	Full or Window	60	Full or Window	60
3K Anamorphic	3072 x 2560	Blackmagic RAW	Window	120	Window	60	–	–
		ProRes 444	Window	70	Window	40	–	–
		ProRes 422	Window	120	Window	60	–	–
2K 16:9	2048 x 1152	Blackmagic RAW	Window	240	Window	120	–	–
		ProRes 444	Window	240	Window	120	Window	120
		ProRes 422	Window	240	Window	120	Window	120
		ProRes 444	Full	120	Full	60	Full	60
		ProRes 422	Full	120	Full	60	Full	60
2K DCI	2048 x 1080	Blackmagic RAW	Window	300	Window	120	–	–
		ProRes 444	Window	240	Window	120	Window	120
		ProRes 422	Window	240	Window	120	Window	120
		ProRes 444	Full	120	Full	60	Full	60
		ProRes 422	Full	120	Full	60	Full	60
HD	1920 x 1080	Blackmagic RAW	Window	300	Window	120	–	–
		ProRes 444	Window	240	Window	120	Window	120
		ProRes 422	Window	240	Window	120	Window	120
		ProRes 444	Full	120	Full	60	Full	60
		ProRes 422	Full	120	Full	60	Full	60

It's important to note that Blackmagic RAW Q0, Q1, Q3 and Q5 use variable bit rate compression to achieve constant quality. Q0, Q1, Q3 and Q5 data rates depend on the complexity of the image subject matter and can vary considerably throughout a clip.

#### Maximum Frame Rates for URSA Mini 4K

Format	Resolution	Codec	Sensor scan	Max Frame Rate
UHD	3840 x 2160	ProRes 444	Full or Window	40
		ProRes 422	Full or Window	60
HD	1920 x 1080	ProRes 444	Window	80
		ProRes 422	Window	120
		ProRes 444	Full	60
		ProRes 422	Full	60

#### To select your desired codec and resolution on Blackmagic URSA Mini.

- 1 Press the 'menu' button on the control panel.
- 2 Navigate to the first page of the 'record' tab.
- 3 Tap your desired combination of codec, quality, and resolution.
- 4 If you want to record using a windowed sensor area, navigate to page 2 of the 'record' menu and enable 'window sensor.' To record with the full sensor, set this to 'off'.
- 5 Press 'menu' to exit.

#### Recording Formats and Project Frame Rates

After setting your codec and resolution, you should set your 'project' and 'sensor' frame rates. Refer to the 'recording' section in this manual for more information about frame rates.

The project frame rates available for all URSA Mini cameras are as follows:

23.98, 24, 25, 29.97, 30, 50, 59.94, and 60 frames per second.

When using Blackmagic RAW and ProRes codecs up to ProRes 422 HQ, the maximum project frame rate is 60 frames per second at all resolutions. When using ProRes 444 and ProRes 444 XQ codecs, the maximum project frame rate is dependent on the resolution.

For example, on URSA Mini Pro 4.6K G2, the maximum project frame rate when using ProRes 444 codecs is 60 frames per second up to 4.6K 2.4:1. If you increase the resolution to full sensor 4.6K, the maximum project frame rate is 30 fps. On the original URSA Mini Pro 4.6K, the maximum project frame rate for ProRes 444 codecs is 60 frames per second up to 2K 16:9. If you change the resolution to 3K anamorphic or higher, the maximum project frame rate is 30 fps. The difference is due to the increased processing required for higher resolutions when using ProRes 444 and ProRes 444 XQ.

#### Trigger Record

You will also need to set your equipment to enable SDI trigger recording to make sure it responds to the trigger signal from your URSA Mini. If your SDI equipment supports SDI trigger recording, it can usually be enabled using your SDI equipment's settings menu.

Your URSA Mini automatically sends a signal via the SDI outputs that will trigger recording when connected to equipment that supports the SDI trigger record feature, such as Blackmagic Video Assist. This means when you press record on your camera, your external SDI equipment will also start recording, and will stop recording when you press record again.

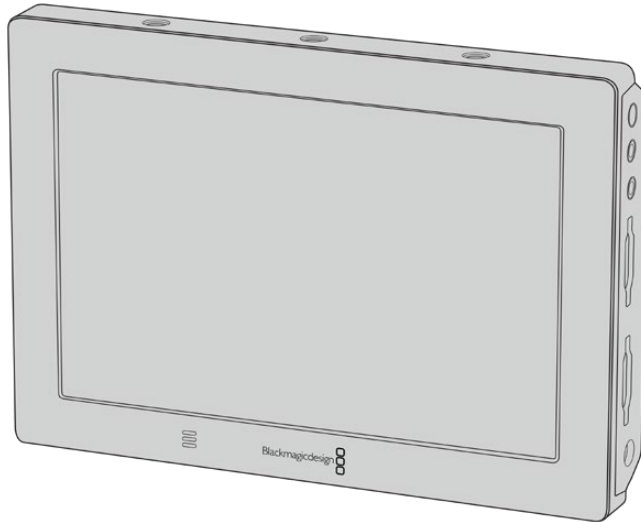

You can trigger recording on other SDI video equipment, for example Blackmagic Video Assist 4K, using the trigger record feature on your camera

**TIP** Sometimes in extremely cold weather conditions, for example 0–5° Celsius and 32–41° Fahrenheit, URSA Mini 4K may take up to thirty seconds to reach optimal running temperature. During this time you can record if you need to, but we recommend waiting for your camera to warm up and stabilize. When optimal running temperature is achieved, your camera will recalibrate to compensate for the sensor's temperature change and you may notice a single white flash frame. This will only occur while not recording and will improve your results when shooting in cold climates.

## Record Duration Tables

Tables are provided showing approximate record duration in minutes and seconds relative to format, project frame rate and media size. The maximum recording duration for your storage media depends on its capacity, the recording format and the frame rate. For example, the storage rate for Apple ProRes 422 HQ at 3840 x 2160 is approximately 880 Mbps. At 24 frames per second, you can record approximately 47 minutes of video on a 256GB CFast 2.0 or SD card. At the same settings you can record approximately 23 minutes of video on a 128GB CFast 2.0 or SD card, which is approximately half the record duration of the 256GB card. These durations are also the same for when recording to SSDs using the URSA Mini Recorder.

It should be noted that record duration on CFast 2.0 and SD cards can also vary slightly between cards from different manufacturers. It can also vary depending on whether the storage media is formatted as exFAT or Mac OS X Extended.

### Record duration tables for URSA Mini Pro 12K

Simple scenes containing less detail tend to require less data than more dense compositions. The values in these tables assume shots with a high complexity, which means you may get slightly longer record times depending on the nature of your shoot.

12K on URSA Mini Pro 12K					
CFast Card	Frame Rate	Blackmagic RAW 5:1	Blackmagic RAW 8:1	Blackmagic RAW 12:1	Blackmagic RAW 18:1
1TB		Duration	Duration	Duration	Duration
	23.98	29 mins	47 mins	70 mins	106 mins
	24	29 mins	47 mins	70 mins	106 mins
	25	28 mins	45 mins	67 mins	101 mins
	29.97	23 mins	37 mins	56 mins	84 mins
	30	23 mins	37 mins	56 mins	84 mins
	50	14 mins	22 mins	33 mins	50 mins
	60	11 mins	18 mins	28 mins	42 mins

8K on URSA Mini Pro 12K					
CFast Card	Frame Rate	Blackmagic RAW 5:1	Blackmagic RAW 8:1	Blackmagic RAW 12:1	Blackmagic RAW 18:1
1TB		Duration	Duration	Duration	Duration
	23.98	66 mins	106 mins	158 mins	238 mins
	24	66 mins	106 mins	158 mins	238 mins
	25	63 mins	101 mins	152 mins	228 mins
	29.97	52 mins	84 mins	127 mins	190 mins
	30	52 mins	84 mins	127 mins	190 mins
	50	31 mins	50 mins	76 mins	114 mins
	60	26 mins	42 mins	63 mins	95 mins

6K on URSA Mini Pro 12K					
CFast Card	Frame Rate	Blackmagic RAW 5:1	Blackmagic RAW 8:1	Blackmagic RAW 12:1	Blackmagic RAW 18:1
1TB		Duration	Duration	Duration	Duration
	23.98	116 mins	186 mins	280 mins	419 mins
	24	116 mins	186 mins	280 mins	419 mins
	25	112 mins	179 mins	268 mins	402 mins
	29.97	93 mins	149 mins	224 mins	335 mins
	30	93 mins	149 mins	224 mins	335 mins
	50	56 mins	89 mins	134 mins	201 mins
	60	46 mins	74 mins	112 mins	168 mins

4K on URSA Mini Pro 12K					
CFast Card	Frame Rate	Blackmagic RAW 5:1	Blackmagic RAW 8:1	Blackmagic RAW 12:1	Blackmagic RAW 18:1
1TB		Duration	Duration	Duration	Duration
	23.98	264 mins	442 mins	631 mins	941 mins
	24	264 mins	442 mins	631 mins	941 mins
	25	254 mins	405 mins	606 mins	904 mins
	29.97	211 mins	338 mins	506 mins	755 mins
	30	211 mins	338 mins	506 mins	755 mins
	50	127 mins	203 mins	304 mins	455 mins
	60	106 mins	169 mins	254 mins	380 mins

**Record duration tables for URSA Mini Pro 4.6K G2, URSA Mini Pro 4.6K, URSA Mini 4.6K and URSA Mini 4K**

Simple scenes containing less detail tend to require less data than more complexity. The values in these tables assume shots with a high complexity, which means you may get slightly longer record times depending on the nature of your shoot.

4.6K								
CFast Card	Frame Rate	Blackmagic RAW 3:1*	Blackmagic RAW 5:1*	Blackmagic RAW 8:1*	Blackmagic RAW 12:1*	ProRes 444 XQ	ProRes 422 HQ	ProRes 422 LT
256GB		Duration	Duration	Duration	Duration	Duration	Duration	Duration
	23.98	28 mins	48 mins	76 mins	115 mins	14 mins	33 mins	70 mins
	24	28 mins	48 mins	76 mins	114 mins	14 mins	33 mins	70 mins
	25	27 mins	46 mins	73 mins	110 mins	14 mins	31 mins	66 mins
	29.976	23 mins	38 mins	61 mins	92 mins	11 mins	26 mins	56 mins
	30	23 mins	38 mins	61 mins	92 mins	11 mins	26 mins	56 mins
	50	13 mins	23 mins	36 mins	55 mins	–	–	–
	59.94	11 mins	19 mins	30 mins	46 mins	–	–	–
	60	11 mins	19 mins	30 mins	46 mins	–	–	–

\* Blackmagic RAW is available on URSA Mini Pro 4.6K and URSA Mini Pro 4.6K G2 only.

ULTRA HD								
CFast Card	Frame Rate	Blackmagic RAW 3:1*	Blackmagic RAW 5:1*	Blackmagic RAW 8:1*	Blackmagic RAW 12:1*	ProRes 444 XQ	ProRes 422 HQ	ProRes 422 LT
256GB		Duration	Duration	Duration	Duration	Duration	Duration	Duration
	23.98	41 mins	68 mins	110 mins	164 mins	21 mins	47 mins	101 mins
	24	41 mins	68 mins	109 mins	164 mins	21 mins	47 mins	101 mins
	25	39 mins	66 mins	105 mins	157 mins	20 mins	45 min	97 mins
	29.976	33 mins	55 mins	88 mins	131 mins	16 mins	38 mins	81 mins
	30	33 mins	55 mins	88 mins	131 mins	16 mins	38 mins	81 mins
	50	19 mins	33 mins	52 mins	79 mins	–	22 mins	48 mins
	59.94	16 mins	27 mins	44 mins	66 mins	–	18 mins	40 mins
	60	16 mins	27 mins	44 mins	66 mins	–	18 mins	40 mins

\* Blackmagic RAW is available on URSA Mini Pro 4.6K and URSA Mini Pro 4.6K G2 only.

HD								
CFast Card	Frame Rate	Blackmagic RAW 3:1*	Blackmagic RAW 5:1*	Blackmagic RAW 8:1*	Blackmagic RAW 12:1*	ProRes 444 XQ	ProRes 422 HQ	ProRes 422 LT
<b>256GB</b>		Duration	Duration	Duration	Duration	Duration	Duration	Duration
	23.98	159 mins	264 mins	418 mins	619 mins	84 mins	189 mins	403 mins
	24	159 mins	264 mins	418 mins	618 mins	84 mins	189 mins	403 mins
	25	153 mins	253 mins	402 mins	595 mins	81 mins	182 mins	387 mins
	29.976	128 mins	212 mins	336 mins	499 mins	68 mins	152 mins	324 mins
	30	127 mins	212 mins	336 mins	499 mins	67 mins	152 mins	324 mins
	50	76 mins	127 mins	203 mins	303 mins	40 mins	91 mins	196 mins
	59.94	64 mins	106 mins	170 mins	254 mins	34 mins	76 mins	163 mins
	60	64 mins	106 mins	170 mins	253 mins	33 mins	76 mins	163 mins

\* Blackmagic RAW is available on URSA Mini Pro 4.6K and URSA Mini Pro 4.6K G2 only.

Constant quality settings for Q0 and Q5 will display varying record time remaining durations. The estimated duration for Q0 is similar to constant bitrate 3:1, and Q5 will display a similar duration to 12:1, however, as the estimated duration updates every 10 seconds while recording, the best way to gauge how much recording time you have is to record for 20 seconds and monitor the duration in the media area of the touchscreen display.

## Data Rate Tables for URSA Mini Pro 12K

Blackmagic URSA Mini Pro 12K allows you to capture images in such a wide variety of resolutions and frame rates that it is important to understand the implications on the data rate so you can choose the best format and media for your project. Blackmagic Design has thoroughly tested a wide range of CFast cards, SD UHS-II cards and USB-C drives to determine achievable framerates and Blackmagic RAW compression ratios. For more information, see the 'Storage Media' section. Generally, CFast Cards for URSA Mini Pro 12K can sustain a data rate of around 400 MB/s. These approximate figures should give you a good starting point for what rates and resolutions you will be able to achieve.

As URSA Mini Pro 12K can record at extremely high data rates, you may wish to double the bitrate your media is normally capable of by striping the recording across two cards. To do this, insert a pair of CFast or SD Cards and switch on the 'record RAW on 2 cards' option in the 'record' menu. Since this relies on striping across both cards sequentially, the data rate of the slowest card will be the limiting factor, so you are advised to use two cards of the same or similar spec. You can also stripe between a CFast card in storage slot 1 and a USB-C disk in storage slot 2. When you use the 'Record RAW on 2 Cards' option, the speed limit is twice the data rate of the slowest card in the striped array. For more information, see the 'Record RAW on 2 Cards' section.

Blackmagic RAW constant bitrate options are designed to give you predictable file sizes and data rates. When you are shooting a highly detailed scene or fast motion, a constant bitrate option compresses the image with a constant maximum to make sure the bitrate is kept at or under the level specified at all times. This makes it easy to understand exactly what speeds your media will need to sustain and will also give you a good estimation of how long you can shoot with your media.

### Maximum Data Rates at 24p with Blackmagic RAW Constant Bitrate

Format		Resolution	Frame Rate	Blackmagic RAW 5:1	Blackmagic RAW 8:1	Blackmagic RAW 12:1	Blackmagic RAW 18:1
12K	17:9	12288 x 6480	24	578 MB/s	361 MB/s	241 MB/s	160 MB/s
	16:9	11520 x 6480	24	542 MB/s	339 MB/s	226 MB/s	150 MB/s
	2.4:1	12288 x 5112	24	457 MB/s	286 MB/s	190 MB/s	127 MB/s
	6:5 Anamorphic	7680 x 6408	24	358 MB/s	224 MB/s	150 MB/s	99 MB/s
8K	17:9	8192 x 4320	24	257 MB/s	161 MB/s	107 MB/s	71 MB/s
	16:9	7680 x 4320	24	241 MB/s	151 MB/s	101 MB/s	67 MB/s
	2.4:1	8192 x 3408	24	203 MB/s	127 MB/s	85 MB/s	56 MB/s
	6:5 Anamorphic	5120 x 4272	24	159 MB/s	100 MB/s	67 MB/s	44 MB/s
6K	Super 16	6144 x 3240	24	146 MB/s	91 MB/s	61 MB/s	40 MB/s
4K	DCI	4096 x 2160	24	65 MB/s	41 MB/s	32 MB/s	27 MB/s
	16:9	3840 x 2160	24	61 MB/s	38 MB/s	30 MB/s	25 MB/s
	2.4:1	4096 x 1704	24	51 MB/s	32 MB/s	25 MB/s	21 MB/s
	6:5 Anamorphic	2560 x 2136	24	40 MB/s	25 MB/s	20 MB/s	17 MB/s
	Super 16	4096 x 2160	24	65 MB/s	41 MB/s	27 MB/s	18 MB/s

It is important to note that actual storage rates are dependent on image subject matter and may be outside of the range below for highly detailed scenes or very simple scenes.

### Range of Data Rates at 24p with Blackmagic RAW Constant Quality

Format		Resolution	Frame Rate	Blackmagic RAW Q0	Blackmagic RAW Q1	Blackmagic RAW Q3	Blackmagic RAW Q5
12K	17:9	12288 x 6480	24	241-578 MB/s	145-361 MB/s	97-241 MB/s	73-181 MB/s
	16:9	11520 x 6480	24	226-542 MB/s	136-339 MB/s	91-226 MB/s	68-170 MB/s
	2.4:1	12288 x 5112	24	190-457 MB/s	114-286 MB/s	76-190 MB/s	57-143 MB/s
	6:5 Anamorphic	7680 x 6408	24	150-358 MB/s	90-224 MB/s	60-150 MB/s	45-112 MB/s
8K	17:9	8192 x 4320	24	161-321 MB/s	107-214 MB/s	81-161 MB/s	52-129 MB/s
	16:9	7680 x 4320	24	151-301 MB/s	101-201 MB/s	76-151 MB/s	49-121 MB/s
	2.4:1	8192 x 3408	24	127-254 MB/s	85-169 MB/s	64-127 MB/s	41-102 MB/s
	6:5 Anamorphic	5120 x 4272	24	100-199 MB/s	67-133 MB/s	50-100 MB/s	32-80 MB/s
6K	Super 16	6144 x 3240	24	61-146 MB/s	37-91 MB/s	25-61 MB/s	19-46 MB/s
4K	DCI	4096 x 2160	24	129-214 MB/s	65-129 MB/s	41-107 MB/s	30-81 MB/s
	16:9	3840 x 2160	24	121-201 MB/s	61-121 MB/s	38-101 MB/s	28-76 MB/s
	2.4:1	4096 x 1704	24	102-169 MB/s	51-102 MB/s	32-85 MB/s	23-64 MB/s
	6:5 Anamorphic	2560 x 2136	24	80-133 MB/s	40-80 MB/s	25-67 MB/s	18-50 MB/s
	Super 16	4096 x 2160	24	41-81 MB/s	27-54 MB/s	21-41 MB/s	13-33 MB/s



Shooting off speed lets you make creative decisions and achieve the look that you want. URSA Mini Pro 12K can shoot at 12K resolution up to 60 fps and as high as 240 fps in other resolutions. When you shoot high frame rates on URSA Mini Pro 12K, the camera uses extreme bitrates, so it is important to choose an appropriate type of Blackmagic RAW compression.

### Maximum Data Rates at Maximum Framerates with Blackmagic RAW Constant Bitrate

Format		Resolution	Blackmagic RAW 5:1		Blackmagic RAW 8:1		Blackmagic RAW 12:1		Blackmagic RAW 18:1	
			Max Frame Rate	Max Data Rate	Max Frame Rate	Max Data Rate	Max Frame Rate	Max Data Rate	Max Frame Rate	Max Data Rate
12K	17:9	12288 x 6480	40	963 MB/s	60	903 MB/s	60	602 MB/s	60	401 MB/s
	16:9	11520 x 6480	40	903 MB/s	60	847 MB/s	60	565 MB/s	60	376 MB/s
	2.4:1	12288 x 5112	50	951 MB/s	75	892 MB/s	75	595 MB/s	75	396 MB/s
	6:5 Anamorphic	7680 x 6408	60	895 MB/s	60	560 MB/s	60	373 MB/s	60	249 MB/s
8K	17:9	8192 x 4320	120	1,285 MB/s	120	803 MB/s	120	536 MB/s	120	357 MB/s
	16:9	7680 x 4320	120	1,205 MB/s	120	753 MB/s	120	502 MB/s	120	334 MB/s
	2.4:1	8192 x 3408	160	1,353 MB/s	160	846 MB/s	160	564 MB/s	160	375 MB/s
	6:5 Anamorphic	5120 x 4272	120	796 MB/s	120	498 MB/s	120	332 MB/s	120	221 MB/s
6K	Super 16	6144 x 3240	120	727 MB/s	120	455 MB/s	120	303 MB/s	120	202 MB/s
4K	DCI	4096 x 2160	120	322 MB/s	120	201 MB/s	120	161 MB/s	120	134 MB/s
	16:9	3840 x 2160	120	302 MB/s	120	189 MB/s	120	150 MB/s	120	125 MB/s
	2.4:1	4096 x 1704	160	339 MB/s	160	212 MB/s	160	169 MB/s	160	141 MB/s
	6:5 Anamorphic	2560 x 2136	120	200 MB/s	120	125 MB/s	120	99 MB/s	120	83 MB/s
	Super 16	4096 x 2160	240	648 MB/s	240	405 MB/s	240	271 MB/s	240	180 MB/s

### Range of Data Rates at Maximum Framerates with Blackmagic RAW Constant Quality

Format		Resolution	Frame Rate	Blackmagic RAW Q0	Blackmagic RAW Q1	Blackmagic RAW Q3	Blackmagic RAW Q5
12K	17:9	12288 x 6480	60	602-1,445 MB/s	362-903 MB/s	241-602 MB/s	181-452 MB/s
	16:9	11520 x 6480	60	565-1,355 MB/s	339-847 MB/s	226-565 MB/s	170-424 MB/s
	2.4:1	12288 x 5112	75	595-1,426 MB/s	357-892 MB/s	238-595 MB/s	179-446 MB/s
	6:5 Anamorphic	7680 x 6408	60	373-895 MB/s	224-560 MB/s	150-373 MB/s	112-280 MB/s
8K	17:9	8192 x 4320	120	803-1,605 MB/s	536-1,071 MB/s	402-803 MB/s	258-643 MB/s
	16:9	7680 x 4320	120	753-1,506 MB/s	502-1,004 MB/s	377-753 MB/s	242-603 MB/s
	2.4:1	8192 x 3408	160	846-1,609 MB/s	564-1,127 MB/s	423-846 MB/s	271-677 MB/s
	6:5 Anamorphic	5120 x 4272	120	498-995 MB/s	332-664 MB/s	249-498 MB/s	160-398 MB/s
6K	Super 16	6144 x 3240	120	303-727 MB/s	182-455 MB/s	122-303 MB/s	92-228 MB/s

Format		Resolution	Frame Rate	Blackmagic RAW Q0	Blackmagic RAW Q1	Blackmagic RAW Q3	Blackmagic RAW Q5
4K	DCI	4096 x 2160	120	643-1,071 MB/s	322-643 MB/s	201-536 MB/s	147-402 MB/s
	16:9	3840 x 2160	120	603-1,004 MB/s	302-603 MB/s	189-502 MB/s	138-377 MB/s
	2.4:1	4096 x 1704	160	677-1,127 MB/s	339-677 MB/s	212-564 MB/s	155-423 MB/s
	6:5 Anamorphic	2560 x 2136	120	398-664 MB/s	200-398 MB/s	125-332 MB/s	91-249 MB/s
	Super 16	4096 x 2160	240	405-810 MB/s	271-540 MB/s	203-405 MB/s	131-325 MB/s

Actual storage rates for Constant Quality formats are dependent on image subject matter and may be outside of the range above for highly detailed scenes or very simple scenes.

## Playback

### Playing Back Clips

Once you have recorded your video, you can use the transport control buttons to play back your clips.

Press the 'play' button once for instant playback and you'll see your recorded video on URSA Mini's LCD touchscreen. Your clips can also be viewed on any display connected to your URSA Mini's SDI outputs.

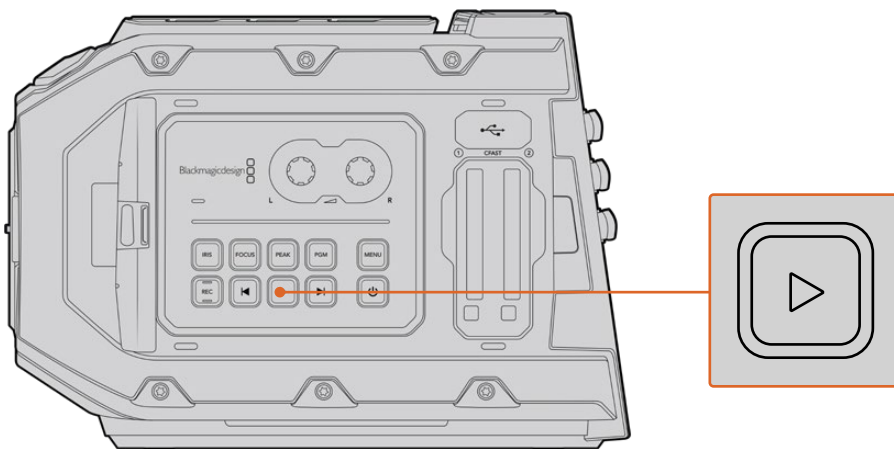

URSA Mini Camera

**TIP** Blackmagic URSA Mini has playback and transport controls buttons on both the internal and ergonomic control panels.

**NOTE** Blackmagic URSA Mini will play back clips of different quality settings as long as they are in the same codec, frame rate and resolution.

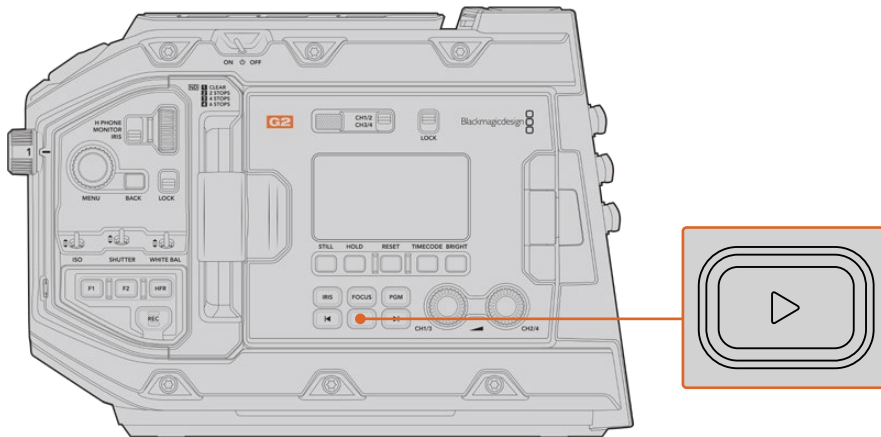

URSA Mini Pro 4.6K G2 Camera

Press the forward and reverse buttons to skip to the start or end of clips. Press the 'reverse skip' button once to go to the start of the current clip or press twice to skip back to the start of the previous clip. Hold the 'forward' or 'reverse skip' button to play or reverse at 2x speed. Once shuttling forward or backwards, press the 'fast forward' or 'reverse skip' buttons twice for 4x, three times for x8 and four times for x16. You can also use the forward and reverse skip buttons to open or close the iris on compatible lenses while recording clips.

When recording a clip using a sensor frame rate that differs from your project frame rate, your clip's playback speed will also differ. For example, imagine you have set your camera's project frame rate to match your post production timeline of 24 frames per second. If you record a clip with your sensor frame rate set to 60 frames per second, your clips will play back in slow motion on both the camera and on your post production timeline.

**TIP** Refer to the 'recording' section of this manual for more information about frame rate.

# Introduction to URSA Mini

Industry standard BNC connectors are located on the right and rear panel of your URSA Mini for SDI connections. There are also two separate LANC inputs, one for the optional Blackmagic URSA Handgrip and one at the rear of the camera for an external LANC controller.

XLR inputs are on the top panel behind the mounting points for professional balanced analog audio on URSA Mini and URSA Mini Pro, and AES digital audio input on URSA Mini Pro. A 4 pin XLR connector is provided on the rear panel for external power input, and an output is available on the right side for powering accessories such as Blackmagic URSA Viewfinder.

The USB port above the storage media slots on your URSA Mini is for connecting to a computer when updating your camera's internal software.

**NOTE** URSA Mini Pro features additional ergonomic controls that make it easy to quickly access the camera's essential settings and functions without opening the foldout touchscreen.

## Camera Front

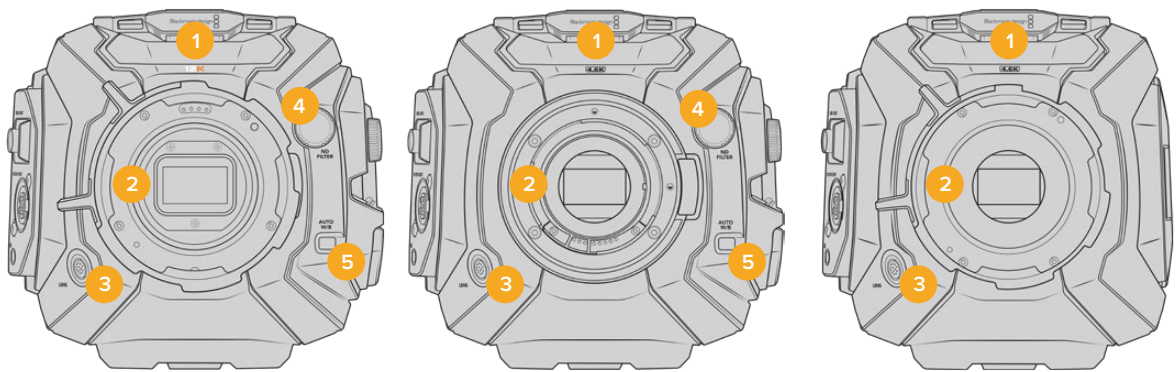

URSA Mini Pro 12K model

URSA Mini Pro 4.6K model

URSA Mini PL model

### 1 Stereo Microphone

Built in high quality stereo microphone. Refer to the 'settings' section for information on microphone audio settings.

### 2 Lens Mount

URSA Mini cameras feature either an EF or PL lens mount. URSA Mini Pro features an interchangeable lens mount that allows switching between EF, F, PL and B4 mounts. Refer to the 'interchangeable lens mount' section for more information.

### 3 Broadcast Lens Connector

This connector provides power and control to compatible PL and B4 mount lenses with 12 pin connections. This connector is only available on URSA Mini PL and URSA Mini Pro models. Refer to the 'using servo zoom lenses' section in this manual for a list of compatible lenses, including PL and B4 models.

### 4 ND Filters

Use this wheel to cycle through three built in neutral density filters, as well as a clear setting. See the section 'URSA Mini Pro control buttons' for more information.

## 5 Auto White Balance

The auto white balance button is marked 'Auto W/B' and is used when you want to set the white balance based on what is currently in the center of the screen. For example, setting auto white balance on a gray card placed in front of the lens. See the section 'URSA Mini Pro control buttons' for more information.

## Left Side – URSA Mini

URSA Mini's left side panel lets you insert CFast cards, access the control panel and change settings. The USB port is located just above the CFast slots so you can easily plug into a computer when updating your URSA Mini's internal software.

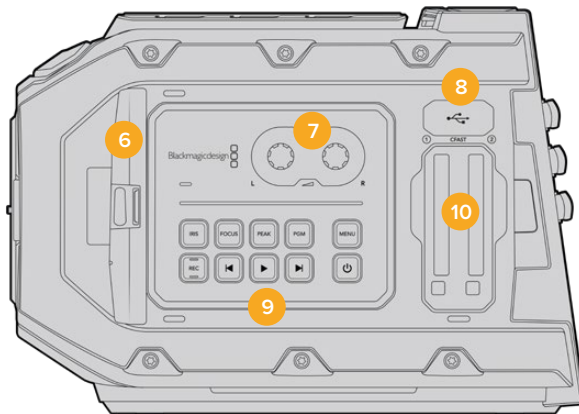

## 6 Fold Out Touchscreen

5 inch fold out touchscreen monitor, pivots for viewing at different camera heights. Refer to the 'touchscreen controls' section for more information.

## 7 Audio Level Adjustment Knobs

Adjustment knobs to set the recording levels for audio channels 1 and 2. Refer to the 'URSA Mini controls' section.

## 8 Mini USB Port

Mini USB Port for updating internal software. Refer to the 'Blackmagic Camera Setup Utility' section for more information.

## 9 Control Panel Buttons

Buttons for powering the camera, record and playback control, focus peaking, accessing the settings menu, plus iris and auto focus control on compatible EF lenses. Refer to the 'URSA Mini controls' section for more information.

## 10 Memory Card Slots

Insert CFast 2.0 cards into the slots for record and playback. Refer to the 'storage media' section.

## Left Side – URSA Mini Pro

URSA Mini Pro's left side panel features additional controls for easy access to all of your camera's essential functions. These controls are split between the forward control panel, the ergonomic control panel located on the outside of the foldout touchscreen monitor, and a control panel on the inside of the foldout monitor.

CFast and SD card slots are located behind the foldout monitor. The USB-C port is above these memory card slots, and is used to connect to a computer to update your URSA Mini Pro's internal software.

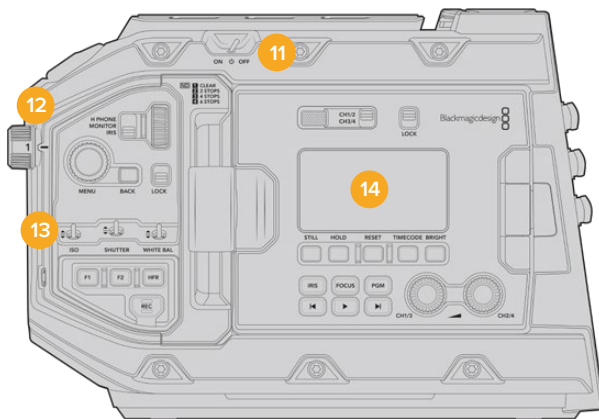

URSA Mini Pro 4.6K model, foldout touchscreen closed

### 11 Power Switch

Power switch for turning on the camera. There is also a backup power switch inside the fold out monitor that allows the camera to be powered on by pressing both the record and forward skip buttons at the same time.

### 12 ND Filters

Your URSA Mini Pro has three internal neutral density filters to adjust the amount of light reaching the sensor. Four settings are available, ranging from clear to six stops of light reduction. Simply turn this wheel to move through the available settings. The filter will click into place for each setting. For more information see the section ‘URSA Mini Pro control buttons’ in this manual.

### 13 Forward Control Panel

The forward control panel provides quick access to all of your URSA Mini Pro’s essential functions. These controls are located for easy access when shooting on a tripod or on the shoulder, and you can use them to adjust settings such as ISO, shutter angle or shutter speed, iris, white balance, frame rate, and more. See the section ‘URSA Mini Pro control buttons’ for more information.

### 14 Ergonomic Control Panel

On the outside of your URSA Mini Pro’s foldout touchscreen monitor, you’ll find an LCD status monitor and a variety of controls for fast, powerful monitoring control. Here you can see all of your camera’s status information at a glance, as well as controlling a variety of powerful monitoring functions. See the section ‘URSA Mini Pro control buttons’ for more information.

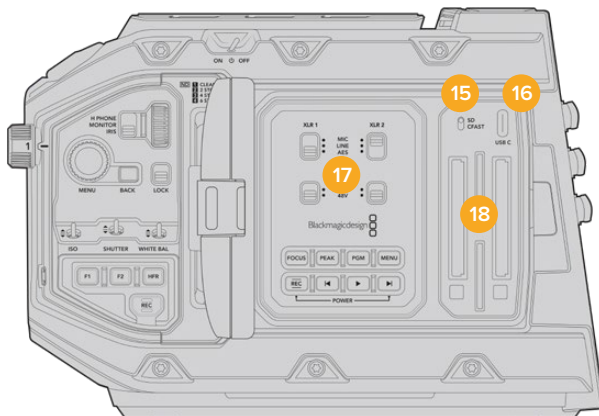

URSA Mini Pro model, foldout touchscreen open

### 15 Storage Media Selection Switch

Use this switch to choose between CFast and SD storage media.

## 16 USB Port

USB-C port for updating internal software. See the section 'Blackmagic Camera Setup Utility' for more information. On URSA Mini Pro G2, you can also use this USB-C port to record to URSA Mini Recorder or an external USB-C flash disk.

## 17 Internal Control Panel

When your URSA Mini Pro's foldout monitor is open, you have access to the internal control panel. Use the controls here to set your audio inputs as well as phantom power settings. You can also access iris, focus, menu and playback controls and more. See the section 'URSA Mini Pro control buttons' for more information.

## 18 Memory Card Slots

Insert CFast 2.0 cards, SDXC or SDHC cards for record and playback. Please note that you should check the list of certified cards in this manual or on our website. See the section 'storage media' for more information.

## Right Side

URSA Mini's right side panel gives you access to all the video, audio and power connectors plus the rosette mount for the optional Blackmagic URSA Handgrip.

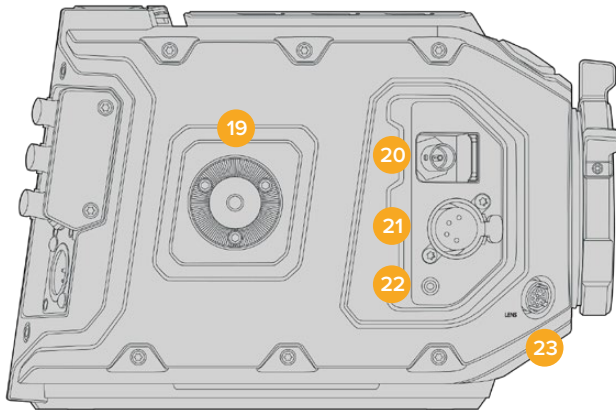

URSA Mini PL model

## 19 Side Rosette Mount

Standard rosette mount for the optional Blackmagic URSA Handgrip. Refer to the 'Getting Started', 'Blackmagic URSA Handgrip' and 'Blackmagic URSA Mini Shoulder Mount Kit' sections.

## 20 HD Monitoring Output

3G-SDI connector for down converted 1080HD output. Use with Blackmagic URSA Viewfinder or external monitors. Refer to the 'camera video output' and 'Blackmagic URSA Viewfinder' sections for more information.

## 21 +12V Power Output

4 pin XLR connector for powering Blackmagic URSA Viewfinder, Blackmagic URSA Studio Viewfinder or external monitors and accessories. Refer to the 'Blackmagic URSA Viewfinder' and 'Blackmagic URSA Studio Viewfinder' sections for more information. This output combined with the Broadcast Lens Connector supplies 12 Volts at up to 2 Amps in total.

## 22 LANC Input

Dedicated 2.5mm TRS LANC connector for the optional Blackmagic URSA Handgrip. Refer to the 'Blackmagic URSA Handgrip' section for more information on connecting the handgrip.



### 23 Broadcast Lens Control Connector

Provides power and control to compatible PL and B4 mount lenses with 12 pin connections. This connection is available on URSA Mini PL and URSA Mini Pro models. This output combined with the +12V Power Output supplies 12 Volts at up to 2 Amps in total.

## Rear Panel

### 24 Battery Mount Plate

Your Blackmagic URSA Mini has mounting points and a recessed moxex connector to supply power to and from the camera as well as carrying some data information. The mounting holes are positioned so that you can attach optional accessories such as battery plates, Blackmagic Camera Fiber Converter or URSA Mini Recorder onto the back of the camera. When in use, the recessed moxex connector can output a regulated 12 Volts at up to 1.5 Amps. For more information, see the chapters for 'Mounting Batteries', 'Getting Started with Blackmagic Fiber Converters' and 'URSA Mini Recorder'.

### 25 LANC

This 2.5mm jack is used for external LANC remote control, such as an external record start stop control mounted to a tripod arm. LANC supports record start and stop, plus iris and focus control using compatible EF lenses. URSA Mini Pro 12K does not have a LANC port on the rear panel. For LANC control of URSA Mini Pro 12K, use the 2.5mm TRS 'LANC input' connector on the right side panel.

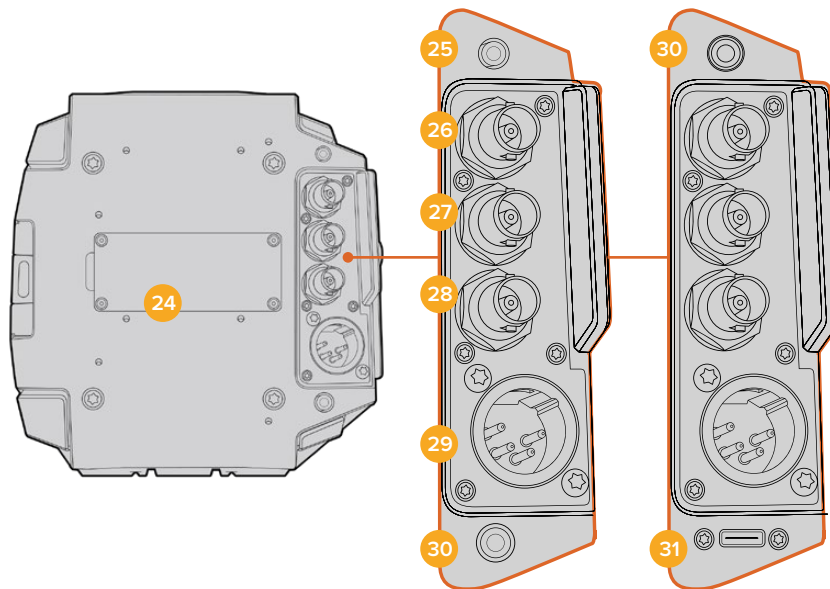

URSA Mini Pro 4.6K G2, URSA Mini Pro 4.6K,  
URSA Mini 4.6K and URSA Mini 4K

URSA Mini Pro 12K

### 26 12G-SDI Out

Blackmagic URSA Mini's 12G-SDI output is used to send HD and Ultra HD video to SDI equipment such as routers, monitors, SDI capture devices, and broadcast switchers. You can also connect the 12G-SDI output to an external recorder such as the Blackmagic Video Assist for backup recording.

### 27 12G-SDI In

The 12G-SDI input is used for connecting to a switcher or external recorder and can be used to view playback, talkback, tally or external reference signals. When used with an ATEM switcher, you can also adjust the camera functions using the switcher's 'camera control' feature.

If you're using URSA Mini in a live broadcast, you can plug in the switcher's program output and monitor it during the shoot, or check playback from an external recorder. Press and hold the 'pgm' button to see the program feed. For more information, refer to the 'control buttons' section for URSA Mini or 'ergonomic control panel' section for URSA Mini Pro.

To receive tally and talkback via the SDI input, make sure you have set your ATEM Camera ID in the camera's setup menu. If you want to use the SDI input to receive an external reference signal, you will need to select 'program' as your reference source in the setup settings. 'REF' will appear next to the timecode display on your camera's LCD screen when the external reference is locked. Refer to the 'setup settings' in the manual for more information.

On URSA Mini Pro the SDI Input can be used for feeding external timecode to the camera as well. This will lock to the incoming timecode automatically if the frame rate of the incoming SDI signal matches and has valid timecode. The 'EXT' logo will appear on URSA Mini Pro's LCD when external timecode is locked. If you unplug the cable timecode will remain jammed and the logo will switch to 'INT' to let you know it is now running from URSA Mini Pro's internal timecode clock.

### **28 Reference and Timecode In**

This input automatically recognizes and switches between timecode and reference input signals. Synchronize Blackmagic URSA Mini to a common reference signal, such as tri-level sync, by connecting to the 'reference' BNC input marked 'REF In'. It's worth noting that to use a reference signal through this input, you must set your reference source to 'external' in your URSA Mini's setup menu.

Alternatively you can use this connector to match an external timecode source to sync up multiple cameras, or audio and picture when shooting dual-system. This ensures audio and picture, or video from multiple cameras, can be easily synchronized during post production. When external timecode with a matching frame rate is plugged into this connector the camera will lock to the incoming timecode automatically. The 'EXT' logo will appear on URSA Mini's LCD when external timecode is locked. If you unplug the cable, timecode will remain jammed and the logo will switch to 'INT' to let you know it is now running from URSA Mini Pro's internal timecode clock.

You can also set your camera to use the reference signal from an ATEM switcher via the SDI Input. This is helpful when working with ATEM switchers because all cameras can receive program return, camera control, tally, talkback, reference and timecode using a single SDI signal. See the 'setup settings' section in this manual for more information.

### **29 +12V Power Input**

Use the 4 pin 12-20 Volt DC XLR connector to plug in power from external sources such as the supplied power adapter, or portable batteries.

### **30 Headphone/Headset**

The 3.5mm jack output is used for headphone monitoring and talkback. You can plug in iPhone and Android compatible headsets that have a built in microphone for quick and easy talkback. Talkback audio is embedded in channels 15 and 16 of the SDI output.

**TIP** When using URSA Mini or URSA Mini Pro's 3.5mm jack for talkback, a very affordable option is using an iPhone or Android compatible headset. These typically feature inline button that can be used to mute and unmute their microphone. If you would like to use a broadcast headset without this inline switch you can configure your URSA Mini or URSA Mini Pro's function buttons to offer the same functionality. See the 'setup settings' section of this manual for more information.

### 31 USB Port

USB-C 3.1 Gen 2 port with locking connector for recording video from URSA Mini Pro 12K to an external flash disk.

## Top Panel

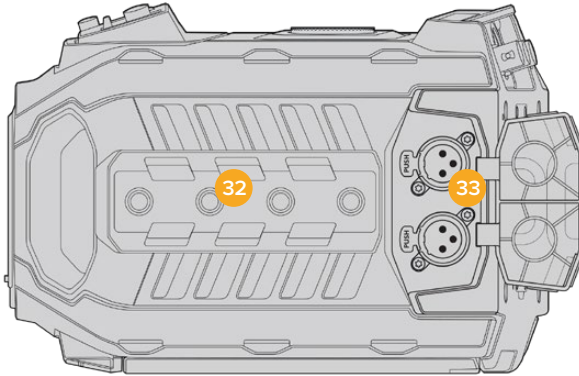

External analog audio can be plugged into the balanced XLR connectors on the top panel

### 32 1/4 Inch Mounting Points

Your camera's top panel contains 4 strong mounting points for attaching the top handle and accessories.

### 33 XLR Audio In

Use the balanced XLR inputs to plug in external analog audio from professional equipment such as audio mixers, PA systems or external microphones. The XLR connectors supply 48V phantom power so you can use microphones that aren't self powered. Refer to the 'internal control panel' section for more information on phantom power.

## Underside

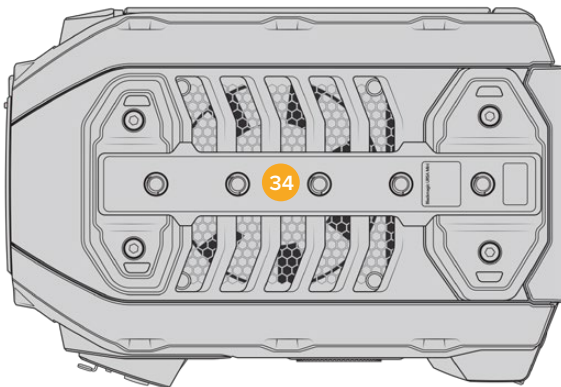

### 34 1/4 Inch Mounting Points

The 5 mounting points on the underside are used for attaching tripod heads, the optional URSA Mini shoulder mount kit and other accessories.

# URSA Mini Controls

Your Blackmagic URSA Mini has a control panel on the left side, behind the fold out monitor and contains all the buttons and adjustment knobs you need to change settings and control audio levels. You can monitor your audio levels using the audio meters on the LCD touchscreen.

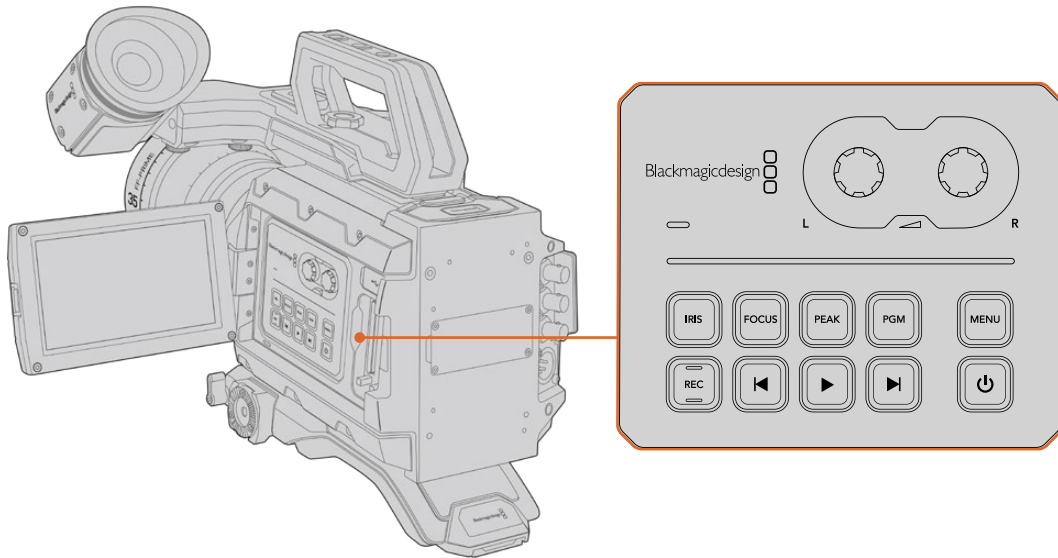

Adjust camera settings using the inside control panel buttons and touchscreen

## Control Buttons

In addition to the inside control panel, your Blackmagic URSA Mini has control buttons on the outside of the LCD and on the optional Blackmagic URSA Handgrip. The iris, focus, record and playback buttons all perform the same function.

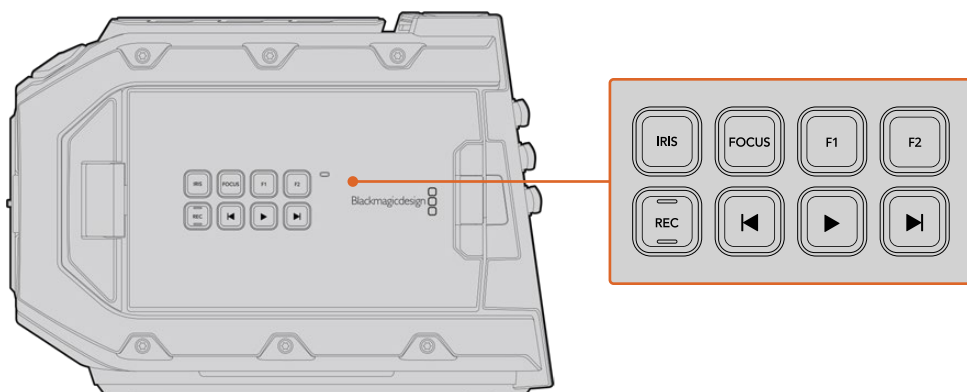

The outside panel buttons let you record and play back clips, turn focus peaking on or off, switch between the program and camera view on the LCD, plus adjust the iris and auto focus when using compatible EF lenses

### Iris

The 'Iris' button activates the automatic aperture setting on compatible lenses. When using video dynamic range settings, a single press of the iris button will set an average exposure based on the highlights or shadows in your shot. When using film dynamic range settings, pressing the iris button sets your exposure to the brightest highlight in your shot.

On URSA Mini EF models, this button works with compatible EF lenses.  
On URSA Mini PL models, this button works with compatible lenses connected to the broadcast lens controller.

To set your aperture manually, press the forward and reverse skip transport buttons.

### **Focus**

When using an EF mount with an EF lens that supports electronic focus adjustments, press the 'focus' button to activate auto focus. A white focus square will appear on the fold out monitor. Anything within the square will be correctly focused. When the lens is focused, the square will disappear.

**NOTE** It's important to know that while most EF lenses support electronic focus, some lenses can be set to manual or auto focus modes, and so you need to ensure your lens is set to auto focus mode.

### **Peak**

Press the peak button to activate focus peaking. Your camera has two focus peaking modes, traditional focus peaking, which artificially sharpens areas of the image that are in focus, and 'colored lines' which overlays the sharp areas of your image with black, white, red, green or blue colored lines. See the 'monitor settings' section of this manual for more information. Focus peaking is not recorded to storage media, but can be displayed via the HD monitoring output and on the fold out monitor by activating overlays using the touchscreen menu.

### **Program**

The program button is marked PGM and lets you switch the LCD between the camera view and any signal plugged into the 12G-SDI input on the rear panel. This means if you're using URSA Mini in a live broadcast, you can plug in the switcher's program output and monitor it during the shoot. Press and hold the program button to see your program feed. The program feed will continue to display whilst the program button is being held. Double pressing the program button will switch to the program feed, and pressing the program button again will exit the program feed. It's worth mentioning that to display a switcher's program output, your camera and switcher must be set to the same frame rate.

**NOTE** When you are setting your reference source for URSA Mini, or URSA Mini Pro, you may experience a small dropout on your camera's outputs when switching between your reference sources. This is because the camera is adjusting its referencing timing to match that of the external source. For this reason it is important not to change this setting during a production, only whilst setting up.

### **Menu**

Press the 'menu' button to open the dashboard. Refer to the 'settings' section for more information about the dashboard feature and how to adjust settings.

## Record

The 'record' button is marked REC on your Blackmagic URSA Mini's control panel, fold out LCD and on the optional Blackmagic URSA Handgrip. Press any of the record buttons to start and stop recording. Refer to the 'recording' section for more information.

## Playback Control Buttons

The playback buttons let you start and stop playback, plus skip to the next or previous clip. On Blackmagic URSA Mini EF, the forward and reverse skip buttons can also be used to open or close the iris when using compatible lenses. Refer to the 'playback' section for more information on how to use the playback buttons.

## Audio Level Adjustment Knobs

Use the built in adjustment knobs to set the recording levels for audio channels 1 and 2. Turn each knob clockwise or counterclockwise to increase or decrease the recording level for each channel of audio. Monitor the corresponding on screen audio meters as you adjust each knob so you can see the best level to set it to.

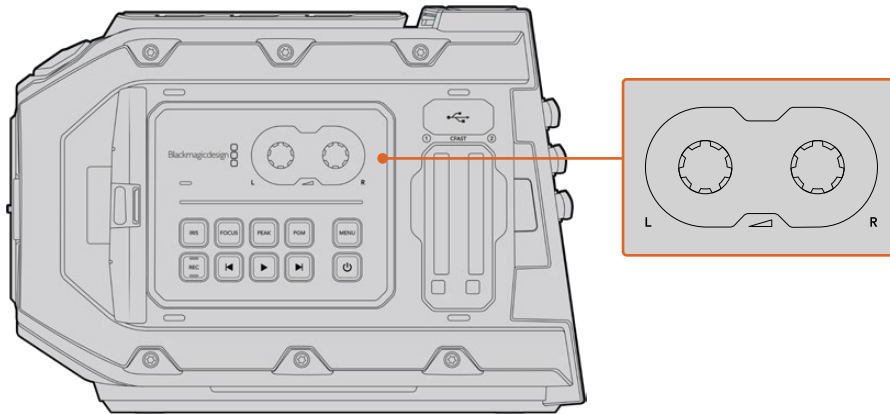

Turn the audio level adjustment knobs clockwise or counterclockwise to increase or decrease your audio recording levels

## Function Buttons

On the outside of Blackmagic URSA Mini's LCD there are two 'function' buttons marked F1 and F2. You can map these to your choice of a variety of commonly used functions using your URSA Mini's 'setup' menu. For more information, see the 'setup settings' section of this manual.

# URSA Mini Pro Control Buttons

Blackmagic URSA Mini Pro has control panels on the chassis, outside and inside of the foldout touchscreen monitor to give you quick, easy access to all of its essential functions as well as powerful monitoring tools. These panels are designed to be close to hand whether shooting from a tripod, handheld or with the shoulder mount kit.

## Forward Control Panel

Your URSA Mini Pro's forward control panel groups together all of the controls you might need to adjust when setting up a shot and recording. These are all designed for easy access while shooting with the foldout monitor closed, such as when using the shoulder mount kit.

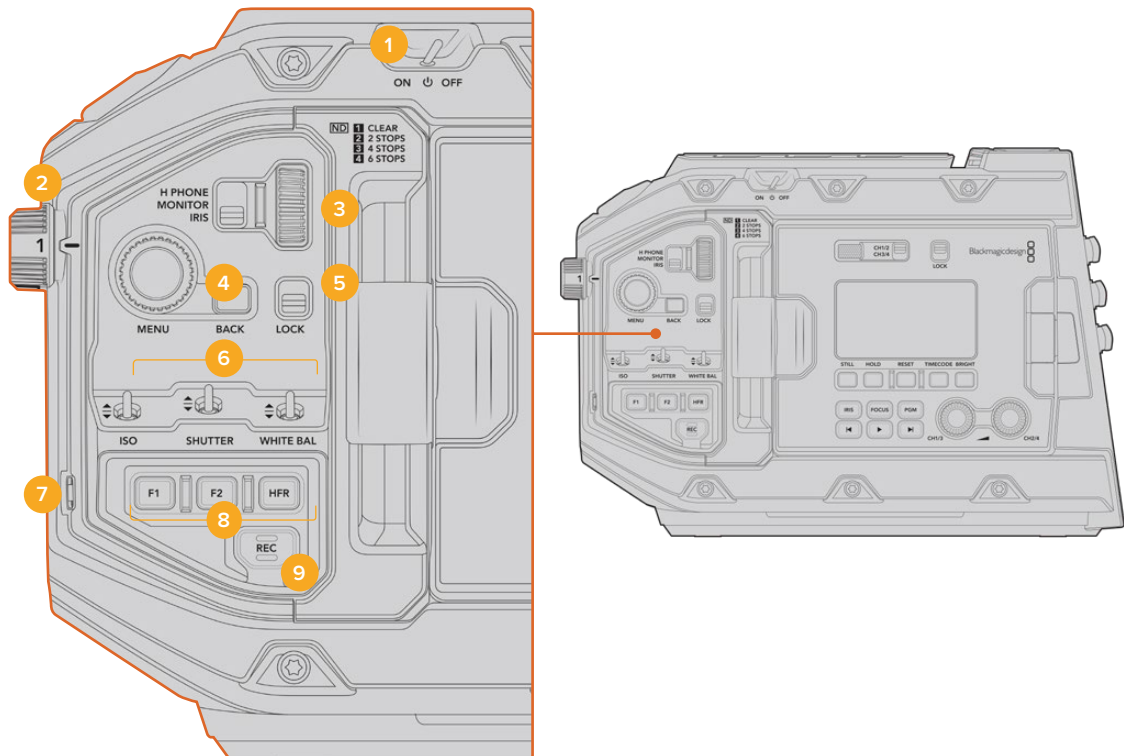

URSA Mini Pro 4.6K forward control panel

### 1 Power Switch

Power your URSA Mini Pro by moving this switch to the 'on' position. Power off by moving the switch to the 'off' position.

**TIP** You can also power your URSA Mini Pro on or off via a combination of control panel switches. Holding the 'rec' and 'forward skip' buttons will power up the camera if it is turned off, or power it off if it is turned on. If your camera's power switch is set to 'on' but your camera is powered down, it may have been powered down via the control panel. Toggle the power switch to return it to normal operation.



## 2 ND Filters

Your URSA Mini Pro has three internal neutral density filters. Together with a clear filter, the available settings are '2,' '4' and '6' stops. These filters allow you to reduce the amount of light reaching your URSA Mini's sensor by a preset number of exposure 'stops'. By reducing the exposure, you can continue shooting at wide apertures in bright conditions such as outdoors on sunny days.

To adjust your neutral density setting, rotate the wheel upwards or downwards. The 'clear' setting means there is no ND filter being used. From settings 2 to 4, the ND filters gradually increase in density so you can decrease light if you need to.

Because different people prefer to use different terms for each ND filter, the measurement of your ND settings can be customized in the LCD menu. You can identify the ND filter number, amount of stops in light reduction, or the fraction representing the amount of light reduced for the filters to suit your preference.

### Neutral Density Filter Settings

Wheel position	ND number	Stops	Fraction
1	clear	0	1
2	0.6	2	1/4
3	1.2	4	1/16
4	1.8	6	1/64

## 3 Settings Wheel

Set this wheel's function by adjusting the adjacent three position switch next to the wheel. The options are 'headphone,' 'monitor' and 'iris'.

### Headphone

When set to 'headphone', the settings wheel will adjust headphone audio levels. Rotate the wheel upwards to increase volume, and downwards to decrease.

### Monitor

When set to 'monitor', the settings wheel adjusts audio levels on your URSA Mini Pro's built in monitor speaker. The speaker is located on the outside of the LCD monitor door and can be used to monitor audio without headphones. Rotate the wheel upwards to increase volume, and downwards to decrease. This function is disabled while recording from the camera's internal microphone to prevent unwanted feedback.

### Iris

When set to 'iris', the settings wheel is used to adjust the aperture of compatible lenses mounted to your URSA Mini Pro. Rotating the wheel downwards opens the iris, and turning the wheel upwards closes the iris. These directions mimic the operation of aperture on adjustable still and cinema lenses.

**TIP** To change aperture settings via the settings wheel, URSA Mini Pro must be fitted with a lens that supports changing aperture via the camera. If you are using a B4 or PL lens connected via the broadcast 12 pin connector, make sure that the lens iris switch on the handgrip is set to 'A' or 'auto'.

#### 4 Menu Wheel

When 'status text' is turned on for your URSA Mini Pro's front SDI output, you can use the menu wheel to navigate many of the head up display features usually accessed via the LCD touchscreen.

Simply press the menu wheel as you would a button to access your URSA Mini Pro's head up display on an external monitor such as Blackmagic SmartView, Video Assist or URSA Viewfinder. While the menu wheel is active, turn the wheel to select features such as LCD monitor options, frame rate, ISO, white balance and tint. Press the wheel to confirm selections and make additional changes, and use the 'back' button next to the wheel to cancel. You can also use the back button to move up a menu level, or exit the menu completely if you're at the top level. On URSA Mini Pro 4.6K, the menu will automatically close after one minute of inactivity.

For more information on setting status text and the controls available, see the 'touchscreen controls' and 'monitor settings' sections of this manual.

#### 5 Lock

Toggle this switch to lock all of the controls on the forward control panel to prevent them from being accidentally adjusted while shooting. Move this switch to the lower position to lock, and the upper position to unlock.

**TIP** When shooting in busy or uncontrolled environments, you can lock your URSA Mini Pro's forward control panel when you leave your camera unattended. This ensures that your settings are not changed unintentionally by others.

#### 6 ISO, Shutter and White Balance Switches

These small switches are used to adjust your ISO, white balance, and shutter settings. They are helpful when you want to make fast adjustments without taking your eyes off the shot. Gently push the switches up or down to make setting adjustments. The switches are spring loaded so they always return to a neutral position.

##### ISO

Push this switch up or down to adjust your camera's ISO setting. Pushing up will increase the setting one interval, and pushing down will decrease one interval. The available settings are 200, 400, 800 and 1600 for URSA Mini and 200, 400, 800, 1600 and 3200 on the URSA Mini Pro.

##### Shutter

Use this switch to adjust the camera's shutter angle or shutter speed, depending on what you have selected in the setup menu. Pushing up will increase the shutter angle or shutter speed to the next available preset, and pushing down will decrease the shutter angle or shutter speed to the next available preset. Holding the switch up or down will move more quickly through available values. There are twenty shutter angle presets between 11.2 and 360 degrees.

**TIP** Your URSA Mini Pro can also suggest flicker free shutter angles or shutter speeds based on the power frequency in your region. These must be selected through the LCD touchscreen menu. For more information see the 'touchscreen controls' section in this manual.

### **White Balance**

This switch is used to adjust the camera's white balance. Pushing up will increase the color temperature by 50K, and pushing down will decrease it by 50K. Holding the switch up or down will move more quickly through available values.

### **7 Auto White Balance**

Pressing this button will reveal a white 'auto white balance' box in the center of the LCD for five seconds. This box will also appear on any SDI output that has 'status text' enabled in the menu settings. The white box indicates the specific area of your image where the white balance will be calculated from, so your gray card should be positioned within this box. Pressing and holding the 'Auto W/B' button for three seconds will perform an 'auto white balance', and the square will change from white to green to confirm that this has been performed successfully.

For more information on enabling status text for your URSA Mini Pro's front or main SDI outputs, see the 'monitor settings' section in this manual.

### **8 F1 and F2**

The F1 and F2 keys are 'function' keys that can be programmed to a variety of commonly used functions using your URSA Mini Pro's 'setup' menu. By default, F1 is set to 'false color' while F2 is set to 'display LUT'.

For more information, see the 'touchscreen controls' section of this manual.

### **HFR**

Use the HFR or high frame rate button to toggle off speed frame rates. To use this button, simply set the off speed frame rate you'd like to use in your URSA Mini Pro's 'frame rate' menu. Pressing this button will toggle between your chosen off speed frame rate and project frame rate. It's worth mentioning that this setting can only be adjusted when the recording is stopped. The HFR button also operates as a 'function key' that you can program to a variety of commonly used functions, or can be disabled.

For more information on project and off speed frame rates, see the 'touchscreen controls' section in this manual.

### **9 Record**

The 'record' button is marked REC on your Blackmagic URSA Mini Pro's left side. Press the record button to start and stop recording. Refer to the 'recording' section for more information.

## Ergonomic Control Panel

On the outside of your URSA Mini Pro's touchscreen monitor, you'll find an LCD status monitor and a variety of monitoring controls. This panel lets you see all of your camera's status information at a glance, as well as monitoring and adjusting audio levels. Automatic focus can be set using compatible lenses and the transport controls let you playback clips.

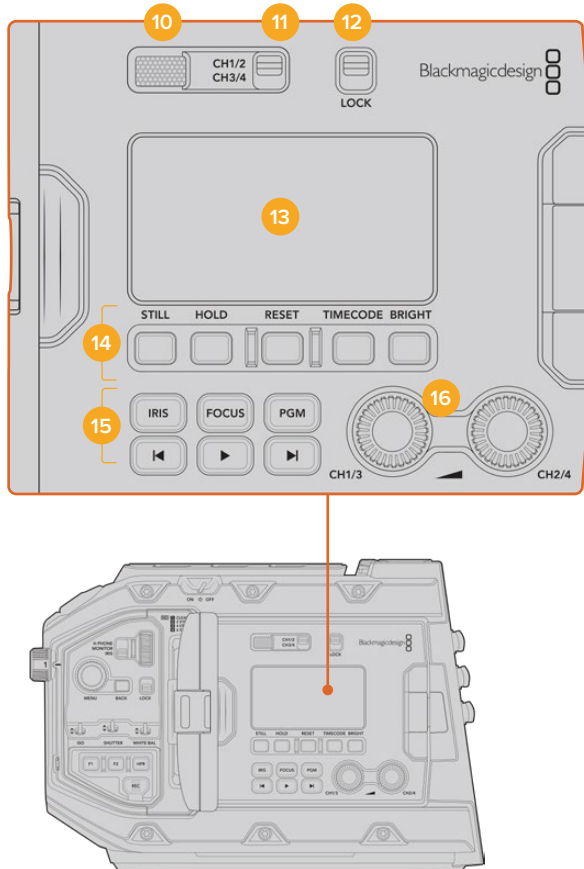

URSA Mini Pro 4.6K ergonomic control panel

### 10 Monitor Speaker

The small speaker built into the outside control panel lets you monitor audio when in playback. It is located where your ear would normally be when shooting with the camera on your shoulder.

To adjust the volume of the speaker, simply rotate the settings wheel as described in the 'URSA Mini Pro Control Buttons' section.

### 11 Monitor Channel Select

Your URSA Mini Pro supports two channels of audio.

### 12 Lock

Use this switch to lock all of the settings on your URSA Mini Pro's ergonomic control panel. The only controls that will remain active while the lock switch is 'on' are the monitor channel select switches.

### 13 Status LCD

This display shows you your URSA Mini Pro's essential settings at a glance, without needing to open the internal touchscreen. This screen is designed to be visible even in bright daylight. The following information is available:

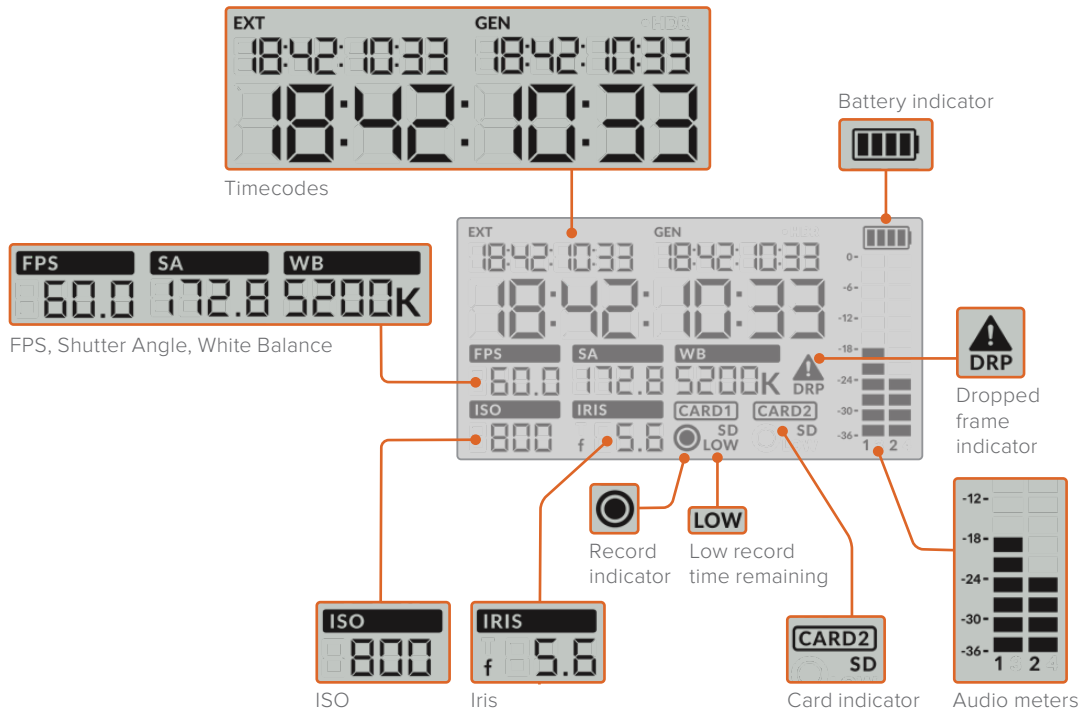

#### Timecodes

Your URSA Mini Pro displays three timecodes. If you have an external timecode connected, this will be shown under the 'ext' indicator in the top left of the status LCD. Your URSA Mini's internally generated timecode is shown next to this under the 'gen' indicator. Both the external and generated timecodes are shown in hours, minutes, seconds and frames.

The larger, main timecode indicator displays your current timecode as either clip duration or timecode. You can switch between these two display modes by pressing the 'timecode' button underneath the status LCD.

#### Battery indicator

If your URSA Mini Pro is running on battery power, this indicator displays remaining battery life in 25% increments. Each of the battery indicator's four bars corresponds to 25% battery life remaining. When your battery drops below 20% charge, the color of the status LED, near the record button begins to flash. It will alternate slowly between red and orange during recording and alternate between white and orange during standby mode.

If the mains power connector is plugged into your camera, the battery indicator shows as full.

#### FPS, Shutter Angle, White Balance

The 'FPS,' 'SA,' and 'WB' indicators display your camera's current frame rate, shutter angle and white balance. The 'fps' indicator shows the current sensor frame rate.

For more information on sensor and project frame rates, see the 'touchscreen controls' section in this manual.

## **ISO**

Displays your camera's currently set ISO.

## **Iris**

Displays your current lens aperture. Depending on your lens type, this will be displayed as an 'f' or 'T' stop.

## **Card Information**

The 'card 1' and 'card 2' indicators will appear on your URSA Mini Pro's status LCD when these slots are occupied.

The 'SD' indicator appears if you are recording on SD cards, and disappears if you are recording on CFast cards.

## **Record Indicator**

While recording, a circular indicator will appear under the card or cards being currently written to.

## **Low Time Remaining**

A 'low' indicator will appear under the relevant card when you have approximately 5 minutes of record time remaining.

## **Audio Meters**

The peak audio meters display audio levels when using the internal microphone, or via external audio when connected. The display is calibrated to dBFS units and features peak hold indicators which stay visible for a short time so you can clearly see the maximum levels reached.

To achieve optimum audio quality, ensure your audio levels do not reach 0 dBFS. This is the maximum level that your camera can record, meaning that any audio that exceeds this level will be clipped, resulting in distortion.

## **Dropped Frame Indicator**

This indicator will flash when your camera detects dropped frames. Once you stop recording, the indicator will remain on the screen to let you know that the previous clip detected dropped frames. This warning disappears the next time you start recording, or if you power cycle the camera. For more information on avoiding dropped frames, see the 'storage media' section in this manual.

**NOTE** You can set your URSA Mini Pro to stop recording if dropped frames are detected. See the 'record settings' section in this manual for more information. This feature is user selectable as you may be able to get away with brief periods of 'burst' recording at higher frame rates or resolutions when shooting to slower media.

## 14 Status LCD Controls

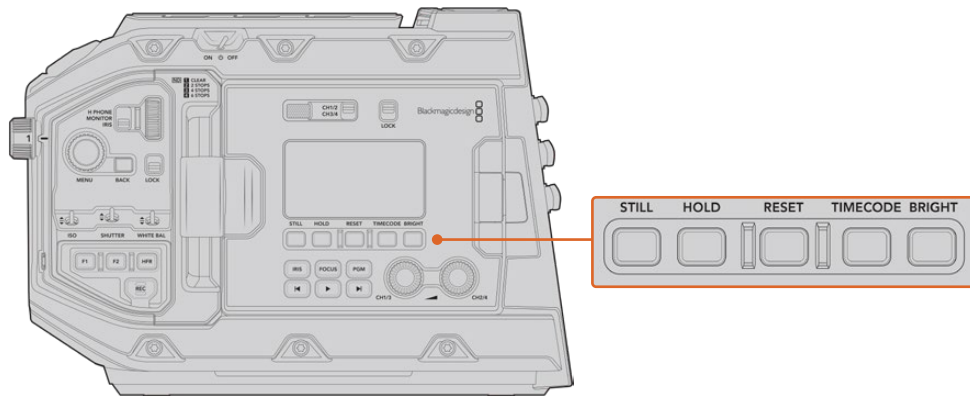

URSA Mini Pro 4.6K status LCD controls

### Still

Press this button to capture a still image. 12K models will capture stills as a single Blackmagic RAW frame. URSA Mini Pro 4.6K models will record stills as a single uncompressed DNG frame. Image files will be saved to the 'stills' folder in the root directory of the media you are currently recording to. These will follow the file naming convention for video clips but the filename will have an 'S001' representing the 'still number' as the last four digits of the filename. To confirm you have successfully saved a still, an image of a camera will show in the top right corner of the URSA Mini touchscreen and the record indicator on the status LCD will flash three times.

### Hold

Use this button to temporarily hold the main status LCD timecode when the timecode is in free running time of day code. The timecode will continue to run in the background and return to its actual position when you release the 'hold' button. While holding you can take note of the timecode for a particular event. This can be useful in electronic news gathering or documentary situations for noting key timecode points.

### Reset

The reset button allows you to reset the timecode to 00:00:00:00 when you are setting your preset timecode.

### Timecode

Press the 'timecode' button to toggle the main timecode display's format between clip duration and timecode. By default the timecode will be free running time of day code as this is the most frequently used. If you press and hold the 'timecode' button for five seconds it will switch the camera into record run timecode and the timecode generator will flash as well as the first two digits of the large timecode display. This indicates that you are now editing your preset timecode and allows you to set a specific timecode number for your preset timecode.

Pressing 'reset' at this stage will zero the timecode and then you can turn and press the menu wheel to set the desired value starting with hours, minutes, seconds and then frames. When you are happy with the timecode, press and hold the 'timecode' button again for three seconds to set this as your preset timecode point. You will notice that the timecode generator now shows this value and will only increment when the camera is recording giving you continuous ascending timecode values. To switch your timecode back to free running time of day code, press the 'timecode' and 'hold' buttons simultaneously for three seconds.

### Bright

Press the 'bright' button to cycle through four brightness settings for your URSA Mini Pro's LCD status display. The settings are 'off,' 'low,' 'medium' and 'high.'

## 15 Control and Playback Buttons

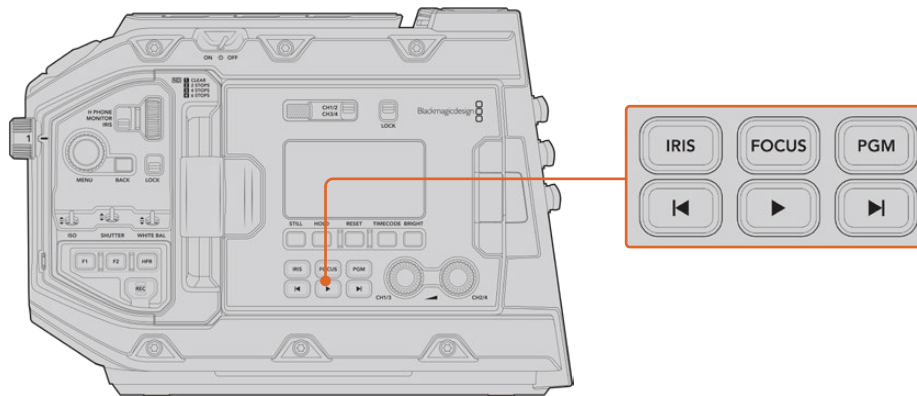

URSA Mini Pro 4.6K control and playback buttons

### Iris

The 'iris' button activates the automatic aperture setting on compatible lenses. When using video dynamic range settings, a single press of the iris button will set an average exposure based on the highlights or shadows in your shot. When using film dynamic range settings, pressing the iris button sets your exposure to the brightest highlight in your shot. This button works with compatible EF lenses and PL lenses connected with a compatible broadcast lens controller.

To set your aperture manually, press the forward and reverse skip transport buttons.

### Focus

When using an EF lens that supports electronic focus adjustments, press the 'focus' button to activate auto focus. A white focus square will appear on any viewfinder or monitor connected to your URSA Mini Pro. Anything within the square will be correctly focused. When the lens is focused, the square will disappear.

**NOTE** Some lenses have both manual and auto focus modes. In order for URSA Mini Pro to be able to auto focus with your lens, you need to ensure that your lens is set to auto focus mode.

### Program

The program button is marked PGM and lets you switch the LCD between the camera view and any signal plugged into the 12G-SDI input on the rear panel. This means if you're using URSA Mini Pro in a live broadcast, you can plug in the switcher's program output and monitor it during the shoot. Press and hold the program button to see your program feed. The program feed will continue to display whilst the program button is being held.

If you want to lock the monitor to display the program input feed, then double press the program button to lock the display to the program feed. Pressing the program button again will exit the program feed and return to the camera view.

### Playback Control Buttons

The playback buttons let you start and stop playback, plus skip to the next or previous clip. When using an EF lens, the forward and reverse skip buttons can also be used to open or close the iris when using compatible lenses. Refer to the 'playback' section for more information on how to use the playback buttons.



## 16 Audio Level Adjustment Knobs

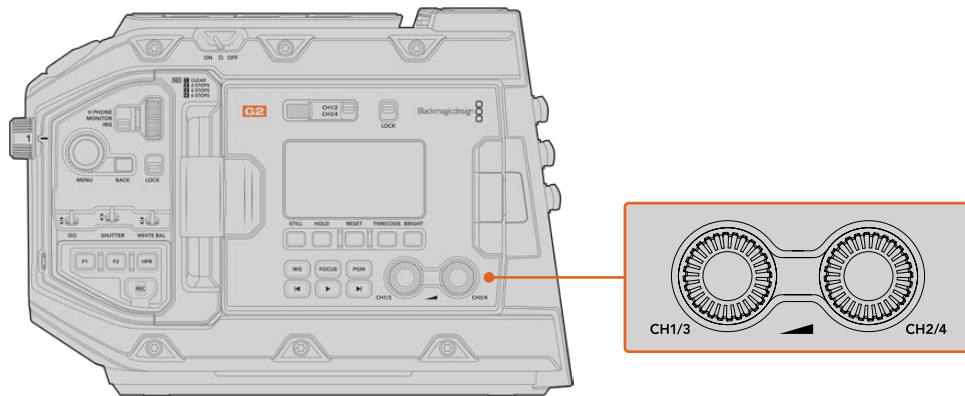

URSA Mini Pro 4.6K G2 audio adjustment knobs

Use the built in adjustment knobs to set the recording levels for audio channels 1 and 2. Turn each knob clockwise or counterclockwise to increase or decrease the recording level for each channel of audio. Monitor the corresponding on screen audio meters as you adjust each knob so you can see the best level to set it to.

## Internal Control Panel

With your URSA Mini Pro's foldout monitor open, you can access the internal control panel. Use the controls here to set your audio inputs as well as phantom power settings, iris, focus, menu and playback controls and more.

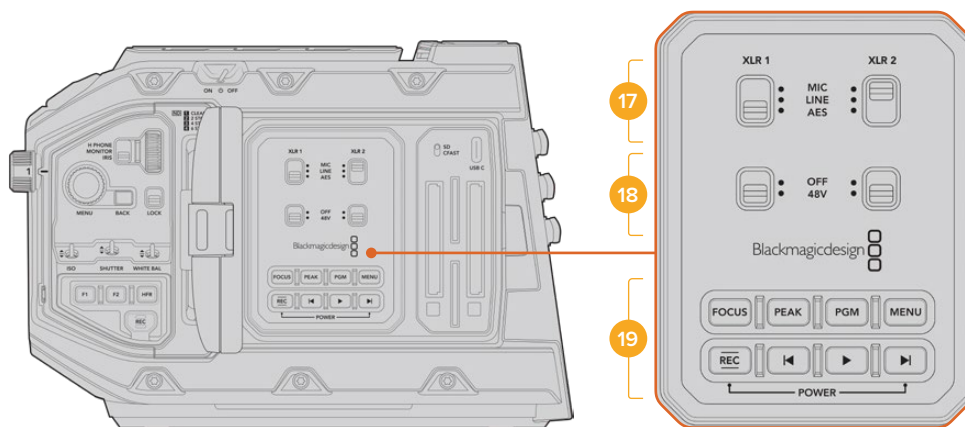

URSA Mini Pro internal control panel

### 17 XLR1 / XLR2

Use these switches to set how your URSA Mini Pro's XLR inputs behave when selected as an input source. The options available are mic audio, line level audio and AES digital audio.

### 18 Phantom Power

Your URSA Mini Pro's XLR inputs can provide 48V phantom power so you can use microphones that aren't self powered. Move this switch to '48V' to enable phantom power for any microphone connected to the XLR above, or 'off' to disable phantom power.

**NOTE** It is standard practice to plug in your XLR cable before switching phantom power on. It is also important to switch phantom power to 'off' when you no longer have a phantom powered microphone connected. Connecting devices that don't have phantom power protection built into their AES XLR outputs whilst still sending phantom power from the camera's XLR audio inputs may damage your equipment. Always ensure that the 48V switch is turned 'off' when you disconnect your microphone.

## 19 Control and Playback Buttons

### Focus

When using an EF mount with an EF lens that supports electronic focus adjustments, press the 'focus' button to activate auto focus. A white focus square will appear on the fold out monitor. Anything within the square will be correctly focused. When the lens is focused, the square will disappear.

**NOTE** Some lenses have both manual and auto focus modes. In order for URSA Mini to be able to auto focus with your lens, you need to ensure that your lens is set to auto focus mode.

### Peak

Press the 'Peak' button to activate focus peaking. Your camera has two focus peaking modes, traditional focus peaking, which artificially sharpens areas of the image that are in focus, and 'colored lines' which overlays the sharp areas of your image with black, white, red, green or blue colored lines. See the 'monitor settings' section of this manual for more information. Focus peaking is not recorded to storage media, but can be displayed via the HD monitoring output and on the fold out monitor by activating overlays using the touchscreen menu.

**TIP** If you are recording your video output to a Blackmagic Video Assist or HyperDeck Studio Mini, you may want to ensure that you don't have peaking switched on for that output. This can be done by using our 'clean feed' feature on your front SDI or main SDI.

For more information on outputting a 'clean feed' see the 'monitor settings' section in this manual.

### Program

The program button is marked PGM and lets you switch the LCD between the camera view and any signal plugged into the camera's 12G-SDI input. This means if you're using URSA Mini Pro in a live broadcast, you can plug in the switcher's program output and monitor it during the shoot. Press and hold the program button to see your program feed. Double press the button to lock the program feed on. Press again to turn the program feed off.

To display a switcher's program output, your camera and switcher must be set to the same resolution and frame rate.

### Menu

Press the 'menu' button to open the dashboard. Refer to the 'settings' section for more information about the dashboard feature and how to adjust settings.

## Record

Press any of the record buttons marked REC to start and stop recording. Refer to the 'recording' section for more information.

## Playback Control Buttons

The playback buttons let you start and stop playback, plus skip to the next or previous clip. When using the EF mount, the forward and reverse skip buttons can also be used to open or close the iris when using compatible lenses. Refer to the 'playback' section for more information on how to use the playback buttons.

**NOTE** You can power your URSA Mini Pro on or off via a combination of internal control panel buttons. Holding the 'rec' and 'forward skip' buttons will power up the camera if it is turned off, or power it off if it is turned on. If your camera's power switch is set to 'on' but your camera is powered down, it may have been powered down via the control panel. Toggle the power switch to return it to normal operation.

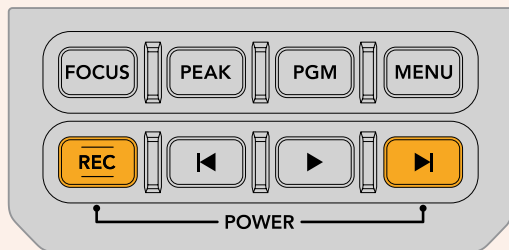

# Touchscreen Controls

## Touchscreen

Your Blackmagic URSA Mini's fold out LCD touchscreen pivots for shooting high and low angles. Buttons on the outside of the LCD panel let you control your URSA Mini when mounted on your shoulder using the URSA Viewfinder and the LCD closed.

## Touchscreen Features

The LCD touchscreen features a touch and gesture based interface that is specifically designed for fast and intuitive user operation. By touching and swiping on different areas of URSA Mini's LCD touchscreen, you can quickly access the camera's functions while shooting.

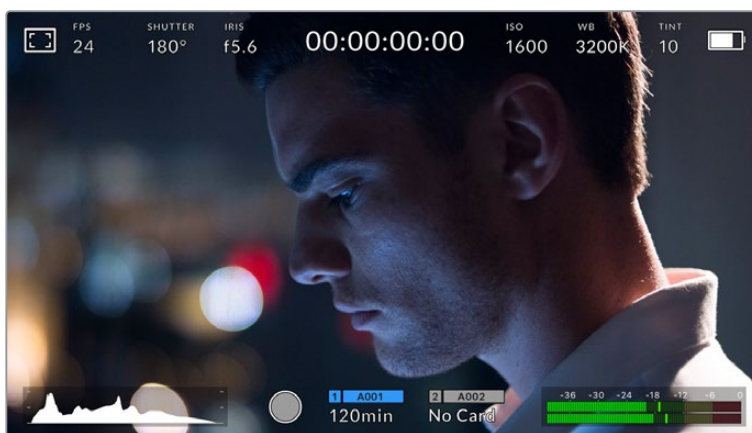

Your URSA Mini's LCD touchscreen has a comprehensive head up display and gives you easy access to your camera's most used settings

## LCD Monitor Options

Tap the 'monitor' icon at the top left of your URSA Mini's LCD touchscreen to access the LCD monitor settings. These settings let you toggle and adjust the appearance of your URSA Mini's monitoring features, including zebra, focus assist, frame guide, and grids. When accessing LCD monitor options, the controls for these features appear in a tabbed menu along the bottom edge of the LCD touchscreen.

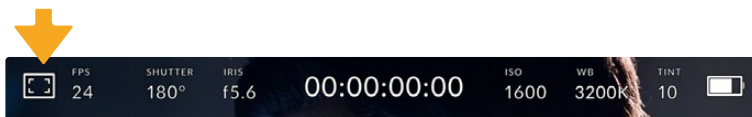

Tap the icon at the top left of your URSA Mini's LCD touchscreen to access LCD monitor options

### Zebra

The 'zebra' setting toggles the appearance of zebra on the LCD touchscreen, as well as setting the zebra level for all URSA Mini outputs.

Zebra displays diagonal lines over areas of your image that exceed a set exposure level. For example, setting zebra to 100% shows which areas are completely overexposed. This is useful for achieving optimum exposure in fixed lighting conditions.

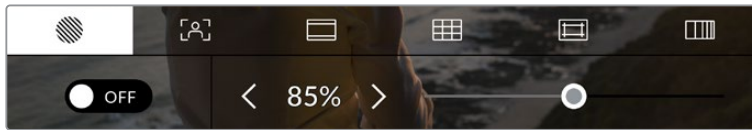

Tap the 'zebra' icon while accessing 'LCD monitor options' to access your URSA Mini's zebra settings

To toggle zebra for the LCD touchscreen, tap the switch icon in the bottom left of the screen while in the 'zebra' tab.

Set the exposure level that zebra appears at by dragging the slider left and right, or tapping the arrow buttons next to the zebra level percentage. Zebra level is adjustable in five percent increments between 75 and 100 percent exposure.

For information on enabling zebra on your camera's front and main SDI outputs, see the 'monitor settings' section in this manual.

**TIP** If you're shooting in variable light such as outdoors on a partly overcast day, setting your zebra level lower than 100 can warn you of potential overexposure.

### Focus Assist

The 'focus assist' setting toggles the appearance of focus assist on the LCD touchscreen, as well as setting the level of focus assistance for all outputs on your URSA Mini.

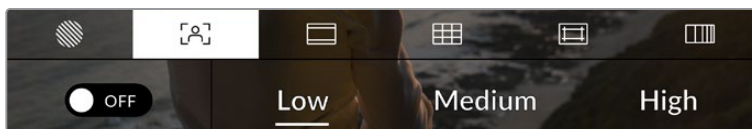

Tap the 'focus assist' icon while accessing 'LCD monitor options' to access your URSA Mini's focus assist settings

To toggle focus assistance for the LCD touchscreen, tap the switch icon in the bottom left of the screen while in the 'focus assist' tab.

To set the level of focus assistance for all outputs on your URSA Mini, tap the 'low,' 'medium' or 'high' titles along the bottom of your touchscreen.

The optimum level of focus assistance varies shot by shot. When focusing on actors, for example, a higher level of focus assistance can help resolve edge detail in faces. A shot of foliage or brickwork, on the other hand, may show distracting amounts of focus information at higher settings.

For information on enabling focus assist on your camera's front and main SDI outputs, see the 'monitor settings' section in this manual.

**TIP** Your URSA Mini has two focus assist modes. You can switch between 'peaking' and 'colored lines' focus assistance in the 'monitor' settings menu. For more information, see the 'monitor settings' section in this manual.

## Touch to focus

You can focus compatible lenses in any region of the image by pressing the LCD screen for a moment where you want to focus. The camera will focus your lens in the chosen location.

Pressing the 'focus' button on the camera or the optional handgrip following this will trigger auto-focus in that specified region. Double pressing the 'focus' button will reset the focus point to the center of the screen.



URSA Mini LCD touchscreen with press to focus

**TIP** If the 'heads up display' is obscuring the area you wish to focus whilst using 'touch to focus', simply swipe it up or down to move it out of the way.

## Frame Guides

The 'frame guide' setting toggles the appearance of frame guides on the LCD touchscreen. You can also choose from eight frame guide options for all outputs on your URSA Mini.

Frame guides include aspect ratios for various cinema, television and online standards.

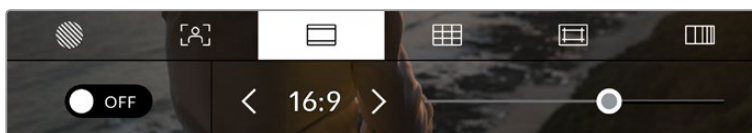

Tap the 'frame guides' icon while accessing 'LCD monitor options' to access your URSA Mini's frame guide settings

To toggle the appearance of frame guides on your URSA Mini's LCD touchscreen, tap the switch icon in the bottom left of the screen.

Choose the frame guide you want to use by dragging the slider left and right, or tapping the arrow buttons on either side of the currently selected aspect ratio.

The available guides are:

### **2.35:1, 2.39:1 and 2.40:1**

Displays the broad widescreen aspect ratio compatible with anamorphic or flat widescreen cinema presentation. The three widescreen settings differ slightly based on the changing cinema standards over time. 2.39:1 is one of the most prominent standards in use today.

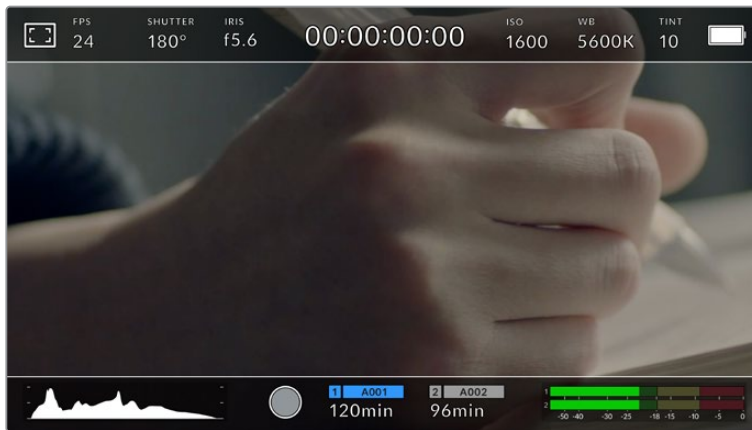

The LCD touchscreen with 2.40:1 frame guides enabled

### **1:1**

URSA Mini Pro can display a square format 1:1 frame guide when composing shots for social media material.

### **2:1**

Available on the URSA Mini Pro, this displays a ratio slightly wider than 16:9 but not as wide as 2.35:1.

### **1.85:1**

Displays another common flat widescreen cinema aspect ratio. This ratio is slightly wider than HDTV 1.78:1 but not as wide as 2.39:1.

### **16:9**

Displays a 1.78:1 aspect ratio compatible with 16:9 HD television and computer screens.

This ratio is most commonly used for HD broadcasting and online videos. The same aspect ratio has also been adopted for Ultra HD broadcasting.

### **14:9**

Displays a 14:9 aspect ratio used by some television broadcasters as a compromise between 16:9 and 4:3 television sets. Ideally, both 16:9 and 4:3 footage remains legible when center cropped to fit 14:9. You can use this as a compositional guide if you know your project may be broadcast by a television station that uses 14:9 cropping.

### **4:3**

Displays the 4:3 aspect ratio compatible with SD television screens, or to help with framing when using 2x anamorphic adapters.

### **4:5**

URSA Mini Pro can display 4:5 portrait format guides when composing shots for smartphone content.

### **Custom Frame Guide Ratio**

To create your own frame guide ratio for a unique appearance, tap on the ratio displayed between the arrow buttons. On the 'custom frameguide' screen tap the backspace button to delete the current ratio, then use the numeric keypad to specify a new ratio. Tap 'update' to apply your custom frame guide ratio and return to shooting.

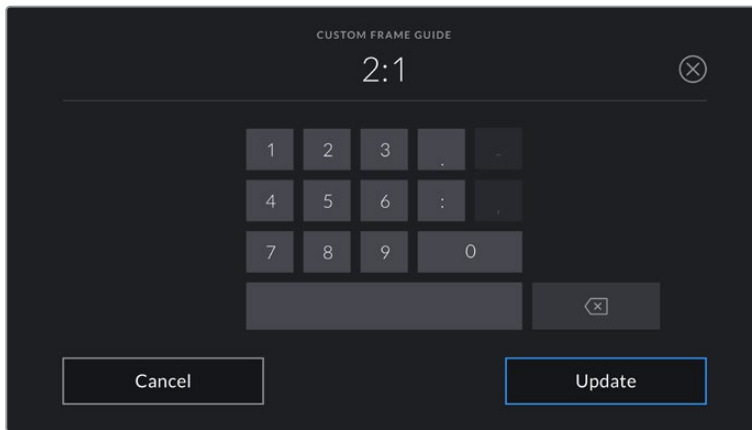

Use the numeric keypad on the 'custom frame guide' screen to enter a new frame guide ratio

**TIP** You can change the opacity of frame guide overlays. For more information see the 'monitor settings' section of this manual.

**NOTE** For information on enabling frame guides on your camera's front and main SDI outputs, see the 'monitor settings' section in this manual.

### Grids

The 'grids' setting toggles the appearance of a rule of thirds grid, crosshair or center dot on the LCD touchscreen, as well as setting the overlay that will be visible on all URSA Mini outputs. URSA Mini Pro 12K also has an option for a horizon meter.



Tap the 'grids' icon while accessing 'LCD monitor options' to access your URSA Mini's grid settings

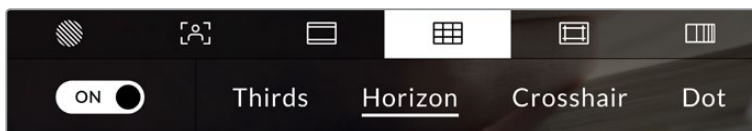

On URSA Mini Pro 12K, the 'grids' setting has options for rule of thirds grid, horizon meter, crosshair or center dot

Grids and crosshairs are overlays that can help with image composition. When 'grids' are enabled, your URSA Mini can show a rule of thirds grid, crosshair or dot. URSA Mini Pro 12K has an additional option so you can overlay a horizon meter.



To toggle the appearance of grids on your URSA Mini touchscreen, tap the switch icon in the bottom left of the screen while in the 'frame guides' tab.

When your URSA Mini is set up and connected to an ATEM switcher as the current program source, and 'grids' are set to 'on', the red 'program' tally outline will automatically illuminate on your LCD.

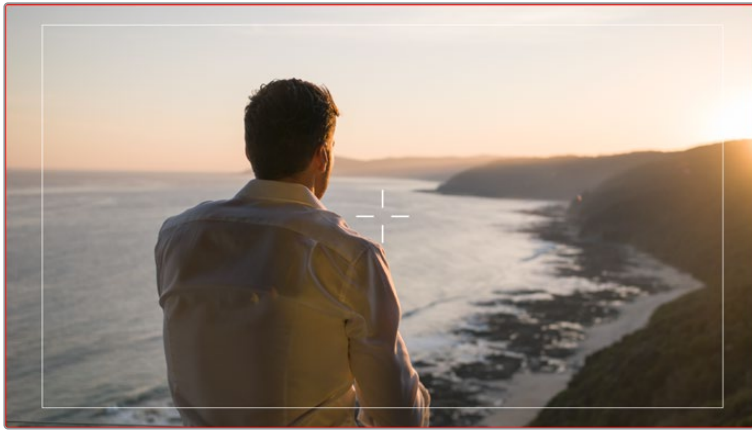

When connected to an ATEM switcher sending a tally signal, a red border will appear around your camera's image preview when grids are set to 'on'

To set which overlay you want to display on all URSA Mini outputs, tap the options at the bottom of the display for 'thirds', 'crosshairs' or 'center dot'. URSA Mini Pro 12K also includes a 'horizon' option.



The rule of thirds grid automatically scales to any on screen frame guides

### Thirds

The 'thirds' setting displays a grid with two vertical and horizontal lines placed in each third of the image. Thirds are an extremely powerful tool to help compose your shots.

For example, the human eye typically looks for action near the points where the lines intersect, so it's helpful to frame key points of interest in these zones. An actor's eyeline is commonly framed along the top third of the screen, so you can use the top horizontal third to guide your framing. Thirds are also useful to maintain framing consistency between shots.

## Horizon





URSA Mini Pro 12K has a horizon meter. It indicates when your camera is rolled left or right and tilted up or down. This can help you keep the horizon is level during handheld shots and balance the camera tilt on a gimbal.

The direction the light gray vertical line moves away from the dark gray crosshair in the middle indicates the direction your camera is rolled. When the camera is tilted down the light gray horizontal line moves up and when the camera is tilted up the light gray horizontal line moves down.

The distance the lines move away from the central crosshair is proportional to the amount of roll or tilt. After you calibrate the camera's motion sensor, the vertical line turns blue when the camera is aligned to the roll axis and the horizontal line turns blue to indicate the camera is aligned to the tilt axis.

Note that if the camera is tilted straight down for an overhead shot or straight up, the horizon meter takes this into account. If you roll the camera to shoot in portrait orientation, the horizon meter rotates its axes 90 degrees.

This table shows examples of the horizon meter indicating tilt and roll of the camera.

Horizon meter	Description
	Straight and level
	Tilted down and level
	Straight and rolled left
	Tilted up and rolled right

For normal use, calibrate the horizon meter for straight and level operation. If you want to use the horizon meter to help maintain a consistent 'dutch angle' or a consistent tilt for a low or high shot, you can calibrate the horizon meter at an incline. For information on how to calibrate the horizon meter, see the 'motion sensor calibration' section.

## Crosshair

The 'crosshair' setting places a crosshair in the center of the frame. Like thirds, the crosshair is a very useful compositional tool, making it easy to frame the subject of a shot in the very center of a frame. This is sometimes used when filming scenes that will be assembled using very fast cuts. Keeping viewers' eyes focused on the center of a frame can make rapid editing easier to follow.

## Center Dot

The 'center dot' setting places a dot in the center of the frame. This works in exactly the same way as the 'crosshair' setting, albeit with a smaller overlay that you may find less intrusive.

You can enable a combination of 'thirds' and 'crosshairs' or 'thirds' and 'center dot' by tapping both options in the 'grids' menu. 'Crosshairs' and 'center dot' cannot be selected together.

**TIP** For information on enabling grids on your URSA Mini's front and main SDI outputs, see the 'monitor settings' section in this manual.

## Safe Area Guides

The 'safe area guides' setting toggles the safe area guides on or off the LCD touchscreen, as well as setting the size of safe area guides for all outputs on your URSA Mini.

Safe areas can be used in broadcast production to ensure that the most important parts of a shot can be seen by viewers. By keeping the most important parts of your shot within a central 'safe area,' you can avoid cropping on some televisions, as well as leaving space for a broadcaster to add bugs, news tickers and other overlays along the edges of the screen. Many broadcasters require footage to be submitted within a 90% safe area.

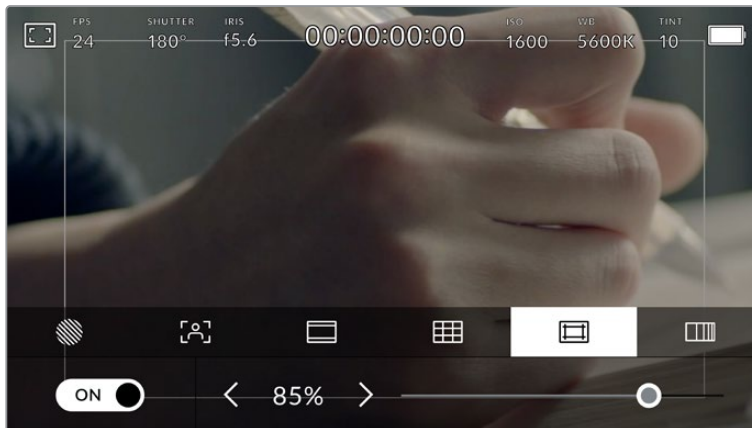

The 'safe area' indicator set to 85%

Safe area guides can also be used to assist with framing your shot where you know that the shot will be stabilized in post production, which can crop the edges of the image. They can also be used to indicate a specific crop.

For example by setting it to 50% whilst recording at Ultra HD 3840x2160 you can see what a 1920x1080 crop of the frame would look like. The safe area guides also scale to your frame guides, so they will adjust to indicate the chosen percentage of your target frame.

To toggle safe area guides for the LCD touchscreen, tap the switch icon in the bottom left of the screen while in the 'safe area guides' tab. To set the level of safe area guides for all outputs on your URSA Mini, tap the left or right arrows on either side of the current numerical value at the bottom of your touchscreen. Alternatively, you can drag the slider left or right.

## False Color

The 'false color' setting toggles the appearance of false color exposure assistance on the LCD touchscreen.

False color overlays different colors onto your image that represent exposure values for different elements in your image. For example, pink represents optimum exposure for lighter skin tones, while green is a good match to darker skin tones. By monitoring the pink or green false color when recording people, you can maintain consistent exposure for their skin tones.

Similarly, when elements in your image change from yellow to red, that means they are now over exposed.

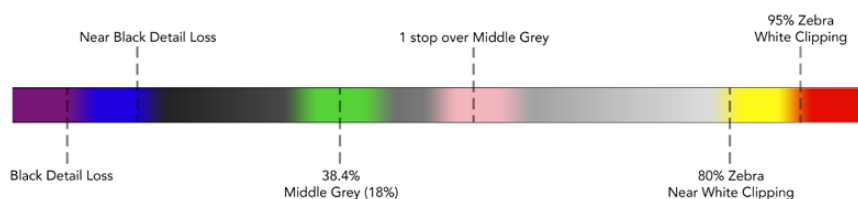

False Color Chart

To toggle false color for the LCD touchscreen, tap the switch icon in the bottom left of the screen while in the 'false color' tab.



The 'false color' exposure assistance tab

## ND Filter indicator

Adjusting your URSA Mini Pro's ND filter will display the ND filter indicator in the top left of the LCD touchscreen and any SDI outputs set to show status text. This indicator will remain on in your 'status text' when you have an ND filter engaged. When you have it set to the position where there is no ND filter, the 'clear' text will disappear after four seconds.

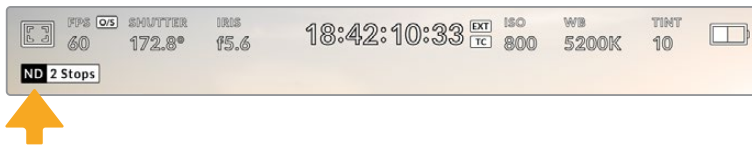

Adjusting your URSA Mini Pro's ND filter setting will reveal the ND filter indicator

**NOTE** You can adjust the terminology used by the ND filter indicator to reflect the conventions you're used to. The options are ND number, stops and fractions. You can set your preferred format in your URSA Mini Pro's 'setup' menu.

## LUT indicator

The LUT icon will be visible on the LCD, front SDI or main SDI when 'status text' is switched on and you have a LUT applied to that output.



The LUT icon lets you know that you have a LUT applied to the image

## Frames Per Second

The 'FPS' indicator displays your currently selected frames per second.

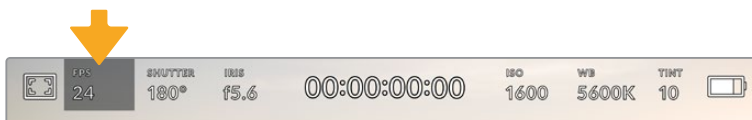

URSA Mini's frames per second indicator. Tap this to access frame rate settings

Tapping the 'FPS' indicator lets you change your camera's sensor and project frame rates via a menu at the bottom of your LCD touchscreen.

### Project frame rate

The project frame rate is URSA Mini's recording format frame rate and provides a selection of common frame rates used in the film and television industry. This frame rate is normally set to match your playback speed used in your post production workflow.

Your Blackmagic URSA Mini has 8 project frame rate settings including 23.98, 24, 25, 29.97, 30, 50, 59.94 and 60 frames per second.

To adjust your URSA Mini's project frame rate while in the 'FPS' menu, tap the left or right arrows next to the current frame rate at the bottom left of your touchscreen. Alternatively, you can drag the slider left or right.

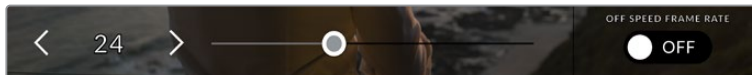

Tap the arrows on either side of the project frame rate or move the slider to make adjustments

**TIP** Your URSA Mini's project frame rate also sets the frame rate of the front and main SDI outputs.

### Sensor frame rate

The sensor frame rate sets how many actual frames from the sensor are recorded every second. This frame rate will affect how fast or slow your video will play back at your set project frame rate.

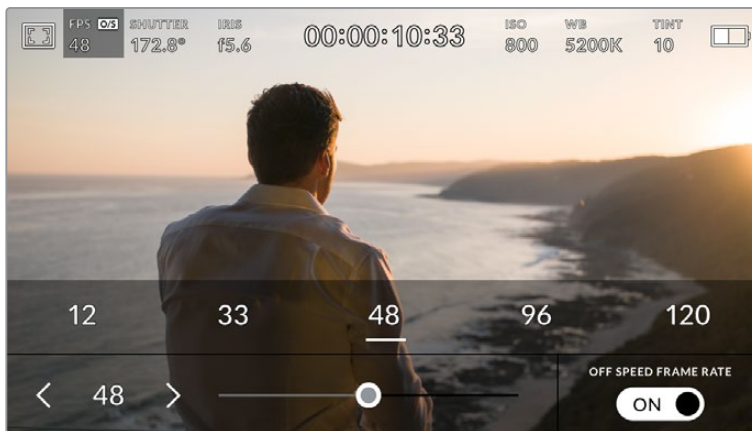

With 'off speed frame rate' enabled, tap the arrows on either side of the sensor frame rate, move the slider or tap one of the presets to make adjustments

By default, your URSA Mini's project and sensor frame rates are matched for a natural playback speed. However, by tapping the 'off speed frame rate' switch icon in the bottom right hand side of your URSA Mini's 'FPS' menu, you can independently set your sensor frame rate.

To change your sensor frame rate, tap the arrows next to the sensor frame rate indicator in the lower left of your touchscreen. You can also drag the slider left or right to increase or decrease the frame rate. Once you release the slider, the sensor frame rate will be selected. Above the slider, you can select a recommended off speed frame rate that is based on your current project frame rate.

You can create dynamic and interesting speed effects in your clips by varying the sensor frame rate. Setting the sensor frame rate higher than your project frame rate will create slow motion during playback. Alternatively, the lower your sensor frame rate, the faster your clips will appear. The principle is similar to overcranking and undercranking a film camera. Overcranking speeds up the sensor frame rate so you can stretch out moments in time during playback to enhance emotion. Undercranking slows down the sensor frame rate so you can increase the action in fast moving scenes. The creative possibilities are endless and entirely up to you!

For information on the maximum frame rates available for each recording format and codec, refer to the table in the 'recording' section of this manual.

**NOTE** When 'off speed frame rate' is selected your URSA Mini's audio and video are no longer synced. This is true even if you set the same project and sensor frame rate. For this reason, 'off speed frame rate' should never be selected if you want to guarantee audio syncing.

## Shutter

The 'Shutter' indicator displays your shutter angle or shutter speed. By tapping this indicator, you can manually change your URSA Mini's shutter values or configure shutter priority auto exposure modes. On URSA Mini 4.6K and URSA Mini Pro, the shutter measurement setting can be used to select whether to display shutter information as 'shutter angle' or 'shutter speed'. See the 'setup settings' section in this manual for more information.

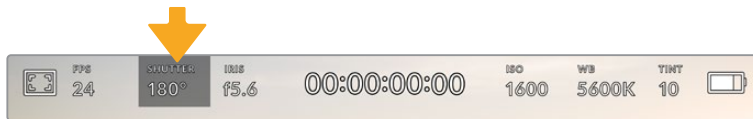

Your URSA Mini's shutter indicator. Tap this to access shutter settings

Shutter angle or shutter speed defines the level of motion blur in your video, and can be used to compensate for varying light conditions. 180 degrees is the optimum shutter angle for capturing satisfying motion blur in most conditions, with the equivalent being a shutter speed of 1/50th of a second. However as lighting conditions change, or the amount of movement in your scene increases, you may decide to adjust accordingly.

For example, 360 degrees is considered 'wide open' and allows maximum light onto the sensor. This is useful for low light conditions with subtle movement in your scene. Alternatively, if shooting subjects with a lot of movement, a narrow shutter angle like 90 degrees will provide minimal motion blur for sharper, crisper images. The equivalent shutter speeds compared to shutter angle depends on the frame rate you are using. For example, if you are shooting at 25 frames per second, then 360 degrees will equate to 1/25th, and 90 degrees will equate to 1/100th of a second.

**NOTE** When shooting under lights, your shutter can affect the visibility of flicker. Your URSA Mini will automatically calculate a flicker free shutter value for your current frame rate. It will display up to three suggested flicker free shutter options at the bottom of the heads up display when adjusting your shutter. These shutter values are affected by mains power frequency in your region. You can set your local power frequency to 50Hz or 60Hz in your URSA Mini's setup menu. See the 'setup settings' section in this manual for more information.

Tapping the 'shutter' indicator brings up the suggested shutter values along the bottom of your URSA Mini's touch screen. If you have auto exposure set to 'off,' this screen will show you your currently selected shutter value, as well as the available flicker free shutter values, based on the mains power frequency you have selected in your URSA Mini's 'setup' menu. For more information, see the 'setup settings' section in this manual.

**NOTE** The characteristics of individual light sources may still cause flicker even when using flicker free values. We recommend always performing a test shoot when not using continuous lights.

To select one of the flicker free shutter values, simply tap on one of the displayed shutter values. Tap the arrows on either side of the current shutter value indicator to cycle through some of the most commonly used values.

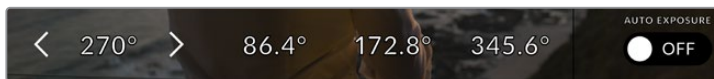

Your URSA Mini will suggest flicker free shutter values based on the mains power frequency you choose in the 'setup' menu

If you would like to choose a specific shutter value, you can do so by double tapping the current shutter indicator at the bottom left of your screen. This opens a keypad that allows you to type in any shutter value with up to two decimal places.

If you type in a shutter speed that is incompatible with your current frame rate, the nearest achievable shutter speed will be used.



The manual shutter keypad allows you to type in any shutter value you wish

Your URSA Mini has three shutter based auto exposure modes. To select one of these, tap the 'auto exposure' button in the far right of the shutter menu.

### Shutter

This setting automatically adjusts shutter value to maintain a constant exposure while keeping iris aperture constant. If you want to maintain a fixed depth of field, this is the setting to choose. It's worth mentioning that the subtle automatic adjustments of the shutter may have an effect on motion blur. It's also worth keeping an eye out for any flicker that may be introduced from various light fixtures on indoor shoots. URSA Mini's auto iris feature is not available when the 'shutter' auto exposure mode is selected.

### Shutter + Iris

Maintains the correct exposure levels by adjusting the shutter, then the aperture. If the maximum or minimum available shutter value is reached and exposure still cannot be maintained, URSA Mini will begin adjusting the aperture to keep exposure constant.

### Iris + Shutter

Maintains the correct exposure levels by adjusting the aperture, then the shutter value. If the maximum or minimum available aperture is reached and exposure still cannot be maintained, URSA Mini will begin adjusting the shutter value to keep exposure constant.

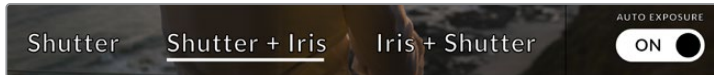

While in the shutter menu, tap 'auto exposure' to access shutter based auto exposure modes

**TIP** When an auto exposure mode that effects the shutter is enabled, a small 'A' will appear next to the shutter angle indicator at the top of your URSA Mini touchscreen.

## Iris

The 'Iris' indicator displays your current lens aperture. By tapping this indicator, you can change the aperture of compatible lenses and configure iris based auto exposure modes.

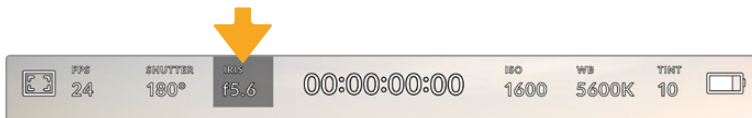

Your URSA Mini's iris indicator. Tap this to access iris settings

**NOTE** To adjust your Iris from the LCD touchscreen, your URSA Mini must be fitted with a lens that supports changing aperture via the camera. If you are using a B4 or PL lens connected via the broadcast 12 pin connector on URSA Mini PL, make sure that the lens iris switch on the handgrip is set to 'A' or 'auto.'

Tapping the 'iris' indicator once brings up the iris menu along the bottom of your URSA Mini touchscreen. You'll see your current lens aperture at the far left of this menu. You can change the aperture by tapping the left and right arrows on either side of the current aperture, or moving the slider left or right.

Tapping the 'auto exposure' switch icon at the far right of the iris menu opens the iris auto exposure menu.

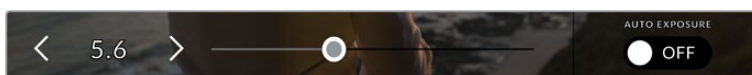

While in the 'iris' menu, tap the arrows on either side of the iris indicator or use the slider to adjust iris settings



This gives you the following auto exposure options.

### Iris

This setting automatically adjusts the aperture to maintain a constant exposure, while keeping shutter angle constant. This will keep motion blur constant, but may affect your depth of field.

### Iris + Shutter

Maintains the correct exposure levels by adjusting the aperture, then the shutter value. If the maximum or minimum available aperture is reached and exposure still cannot be maintained, URSA Mini will begin adjusting the shutter value to keep exposure constant.

### Shutter + Iris

Maintains the correct exposure levels by adjusting the shutter, then the aperture. If the maximum or minimum available shutter value is reached and exposure still cannot be maintained, URSA Mini will begin adjusting the aperture to keep exposure constant.

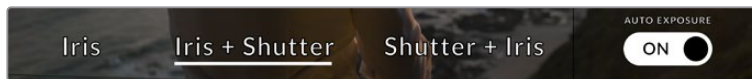

While in the iris menu, tap 'auto exposure' to access iris based auto exposure modes

When an auto exposure mode that effects the iris is enabled, a small 'A' will appear next to the iris indicator at the top of your URSA Mini touchscreen.

**TIP** Automatic exposure works smoothly with compatible B4 or PL lenses which are designed for video or film production. EF lenses may produce noticeable 'steps' in exposure when changing aperture. For this reason, we recommend using only 'shutter' auto exposure mode if shooting on URSA Mini EF.

## Duration Display

At the top of your URSA Mini LCD touchscreen, you'll see your camera's duration display.



Your URSA Mini's duration display. This will turn red while recording

The duration display provides a timecode counter for checking the duration of your clips and monitoring timecode during recording and playback. The counter displays a time sequence showing Hours:Minutes:Seconds:Frames and will progress through the sequence as you record or play back clips. The timecode will turn red during recording.

The displayed duration of each clip starts from 00:00:00:00 for each clip. The clip duration of the current, or last recorded, clip is displayed on the touchscreen. Time of day timecode is embedded into clips for easier post production.

To see the timecode, simply tap the duration display. Tap the duration display again to return to clip duration.

### Additional status indicators may appear around the duration display:

- 
- |          |  |
|----------|--|
| <b>W</b> | Appears to the left of the duration display when your URSA Mini is using a windowed sensor mode. |
|----------|--|
- 
- |           |   |
|-----------|---|
| <b>TC</b> | Appears to the right of the duration display when showing timecode. |
|-----------|---|
- 
- |            |  |
|------------|--|
| <b>EXT</b> | Appears to the right of the duration display if an external timecode is connected and valid. |
|------------|--|
- 
- |            |   |
|------------|---|
| <b>INT</b> | Appears to the right of the duration display if the camera is running off an internal timecode after being 'jam synced' and disconnected. |
|------------|---|
- 
- |            |   |
|------------|---|
| <b>PRE</b> | Appears to the right of the duration display when you are viewing 'preset record run' timecode. |
|------------|---|
- 
- |            |   |
|------------|---|
| <b>REF</b> | Appears when a valid reference source is connected and locked, based on the reference input settings. |
|------------|---|
- 

## ISO

The 'ISO' indicator displays your URSA Mini's current ISO setting, or light sensitivity. Tapping this indicator lets you adjust your ISO to suit varying lighting conditions. The ISO range on URSA Mini is from ISO 200 to 1600, whilst the ISO range on URSA Mini Pro can also be increased to 3200.

The optimum ISO for URSA Mini 4K is 400. The optimum ISO for URSA Mini 4.6K and URSA Mini Pro is 800.

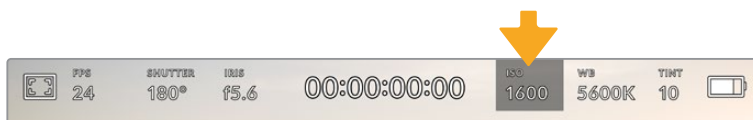

Your URSA Mini's ISO indicator. Tap this to access ISO settings

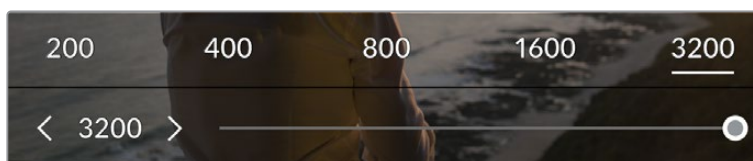

While in the 'ISO' menu, your URSA Mini's ISO settings appear along the bottom of the LCD touchscreen. URSA Mini Pro 4.6K G2 provides a slider below the presets for adjusting your ISO in 1/3 stop increments.

Numerical presets provide the option to select an ISO setting in full stop increments by tapping on the number. URSA Mini Pro 4.6K G2 provides a slider below these presets, that allows you to fine tune your ISO setting in between these presets in 1/3 stop increments.

Depending on your situation, you may choose a lower or higher ISO setting. For example, in low light conditions ISO 1600 can be suitable when shooting on URSA Mini 4.6K but may introduce some visible noise. In bright conditions ISO 200 can provide richer colors.

## White Balance



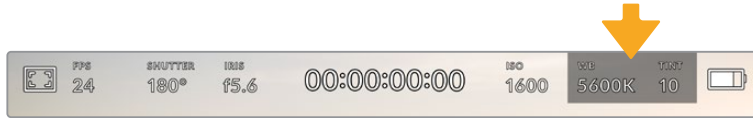

The 'WB' and 'TINT' indicators display your camera's current white balance and tint. Tapping these indicators lets you adjust your camera's white balance and tint to suit varying lighting conditions.



Your URSA Mini's white balance and tint indicators.  
Tap these to access white balance and tint settings

Every light source emits a color. For example, a candle flame emits a warm color, and an overcast sky emits a cool color. White balance settings are used to color balance your image so white stays white by adjusting the mix of orange and blue in your image. For example, when shooting under tungsten lamps which emit a warm, orange light, selecting 3200K adds some blue to the image. This balances the color so white is accurately recorded.

Your URSA Mini comes with white balance presets for a variety of color temperature conditions. These are:

	<b>Bright sunlight</b>	(5600K)
	<b>Incandescent bulbs</b>	(3200K)
	<b>Fluorescent bulbs</b>	(4000K)
	<b>Mixed light</b>	(4500K)
	<b>Cloud</b>	(6500K)

You can customize any of these presets by tapping or holding the arrow icons to the left and right of the temperature indicator in the bottom left of the 'white balance' menu. Each tap moves the color temperature up or down 50K, but holding the arrow icons down will increase these increments for faster changes. Alternatively, you can move the temperature slider in the middle of the 'white balance' menu.

To further dial in your image, you can adjust the 'tint.' This adjusts the mix of green and magenta in your image. For example, adding some magenta can compensate for the green cast of many fluorescent lights. Many of your URSA Mini's white balance presets include some tint.



Tapping the white balance and tint indicator on your URSA Mini gives you access to five presets, as well as a white balance indicator and slider on the left, and a tint indicator on the right. Adjust these to set a custom white balance for your lighting conditions

While in the 'white balance' menu, your camera's current tint setting is shown at the bottom right of the screen. To adjust the tint, simply tap or hold the arrows to the left and right of the tint indicator. The available range is -50 to +50 in one unit increments. Holding down on the arrows speeds up adjustment.

**NOTE** Customizing the white balance or tint will change your preset to 'CWB,' or custom white balance. Custom white balances are persistent; your CWB settings will stay configured between power cycles, and when switching to a preset and back to CWB. This makes it easy to compare a custom white balance to the last preset used.

### Auto White Balance

Your URSA Mini can set white balance automatically. Tapping 'AWB' will bring up the white balance screen.

When setting white balance automatically, a square will be overlaid on the center of your image. Fill this square with a neutral surface such as a white or gray card and tap 'update.' Your URSA Mini will automatically adjust its white balance and tint values to ensure that the average of the white or gray within the white balance square is as neutral as possible. Once updated, this will be set as your camera's custom white balance.





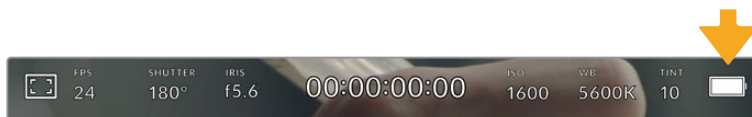

Tapping the 'AWB' icon in the white balance menu will bring up the auto white balance screen. Use this with a white or neutral gray surface to automatically set a neutral white balance

### Power

Your URSA Mini's power status is displayed in the top right of the LCD screen. There are five possible indicators:



Your URSA Mini's power indicator is at the top right of the LCD touchscreen. While using battery power, tapping this toggles between 'voltage' and 'percentage' displays

	<b>AC</b>	Displayed when your URSA Mini is plugged into mains power.
	<b>Percentage</b>	If you are using a percentage accurate battery and plate combination and have your battery display set to 'percentage,' the indicator will display your battery level as a percentage. At 20% charge remaining, the indicator will turn red.
	<b>Battery bars</b>	If your battery display is set to 'percentage' but your battery plate and battery combination does not support percentage accurate battery information, your URSA Mini will display a battery icon that drains in 25% increments. At 20% charge remaining, the battery bar will turn red.
	<b>Voltage</b>	When your battery display is set to 'voltage,' this indicator will display your battery's remaining voltage. When your battery drops below 12.5 volts, this indicator will turn red. Your URSA Mini will automatically shut down once the battery reaches 11.9 volts.
	<b>Fiber</b>	Displayed when you have Blackmagic Camera Fiber Converter attached to your camera and are powering the camera through the SMPTE fiber cable. If you have an XLR power cable plugged into URSA Mini whilst the converter is attached, the AC icon will be displayed instead.

When using battery power, you can switch between 'voltage' and 'percentage' or 'battery bars' power indicators by tapping the power indicator.

**TIP** A list of batteries that support percentage accurate power information is provided in the 'mounting batteries' section of this manual.

## Histogram

At the bottom left of your URSA Mini touchscreen, you'll see the histogram. The histogram shows the contrast between whites and blacks along a horizontal scale.

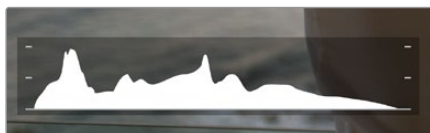

The histogram gives you an indication of the tonal range between shadows and highlights in your clip. It is also a helpful tool for checking the balance of your exposure and to prevent your highlights from clipping.

The left edge of the histogram displays shadows, or blacks, and the far right displays highlights, or whites. When you close or open the lens aperture, you'll notice the information in the histogram moves to the left or right accordingly. You can use this to check 'clipping' in your image shadows and highlights. If the left and right of your edges of the histogram come to an abrupt stop rather than falling off gradually, you may be losing highlight or shadow detail.

**NOTE** If you don't see a histogram in the bottom left of your touchscreen, your LCD monitor settings may be set to display 'codec and resolution.' See the 'monitor settings' section in this manual for more information.

## Record button

Next to the histogram at the bottom of your URSA Mini's touchscreen, you'll see a round gray button. This is the 'record' button. Tap this once to begin recording, and tap it again to stop. While recording, the button and the timecode at the top of your URSA Mini touchscreen will turn red.

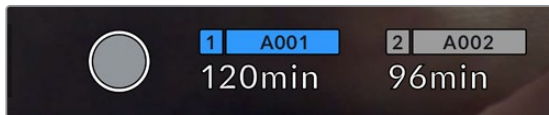

Your URSA Mini's 'record' button, next to the storage indicators at the bottom of the LCD touchscreen



The 'record' button turns red when recording

## Dropped Frame Indicator

The 'record' button will be overlaid with a flashing '!' indicator if your URSA Mini begins dropping frames while recording. The time remaining indicator for the affected card or cards will also turn red. For example, if you are recording in dual card mode and card 1 is dropping frames, the '!' indicator will appear over the 'record' button, and the time remaining indicator on card 1 will turn red. This lets you know if a particular card is too slow for your currently selected codec and resolution. The 'dropped frame indicator' will also display if you have dropped a frame on the previously recorded clip. This indicator will continue to display until another clip is recorded, or the camera is power cycled. Refer to 'Choosing a CFAST 2.0 card' section in this manual, for more information on how to avoid dropping frames.

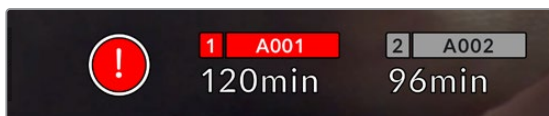

Dropped frame indicator for CFAST card 1 dropping frames

**TIP** If you have the your URSA Mini's status LED enabled, this will rapidly flash red when dropped frames are detected. For more information, see the 'setup settings' section in this manual.

**NOTE** You can set your URSA Mini to stop recording if dropped frames are detected to prevent a situation where you waste time shooting unusable footage if you don't notice the dropped frame indicator. See the 'record settings' section in this manual for more information.

## Recording Time Remaining

At the bottom of your URSA Mini touchscreen, you'll see the storage indicators.

When a CFast card, SD card or SSD is inserted, the storage indicator will show how much recording time is left on the card. The time is shown in minutes and will vary according to your selected frame rate and codec.

The indicator will automatically recalculate if either of these settings are changed. When there is approximately 5 minutes remaining on your card or drive, the indicator text will turn red, and will blink intermittently when there is only 2 minutes remaining. The indicator displays FULL when a card or drive reaches maximum capacity.

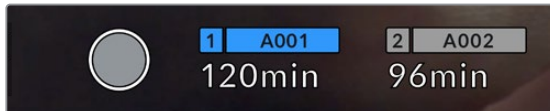

Your URSA Mini's storage indicator will display the name of your CFast card, SD card or SSD and the record time remaining in minutes

The card or drive name will also be shown in a small bar above the time remaining. This bar will turn blue to indicate that the camera will be recording to this card or drive. On URSA Mini Pro 4.6K G2, you can switch recording to a different card or drive using the onscreen display.

Press and hold the name of the card or USB-C flash disk you wish to record to. The bar will turn blue. While recording, the bar will turn red. Tapping the storage indicators will bring up the storage and formatting menu.

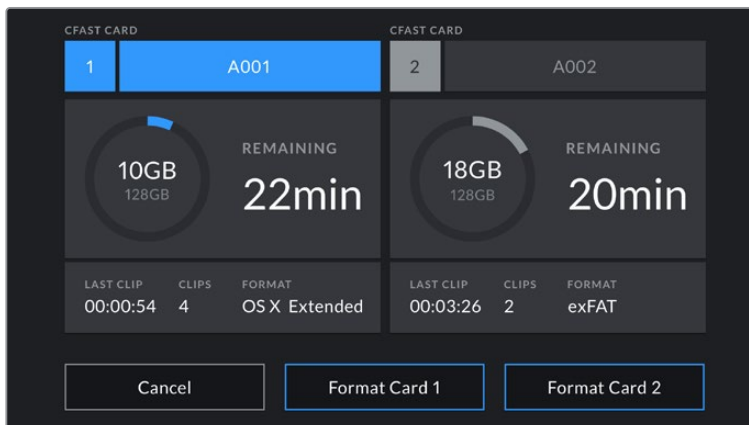

Tap the storage indicators on your URSA Mini's LCD touchscreen to access the storage manager

This menu displays the amount of free space on each CFast card, SD card, SSD or external drive currently connected to your URSA Mini, as well as the name of the card or drive, length of the last clip, total number of clips, and the file format for each card or drive.

You can format your media from this menu. For more information on formatting media using URSA Mini, see the 'preparing media on Blackmagic URSA Mini' section of this manual.

**TIP** Tapping the card or drive name in the storage menu sets it as the active card or drive. Your URSA Mini will fill this card or drive first.

## Audio Meter

The peak audio meters display audio levels for channels 1 and 2 when using the internal microphone, or via external audio when connected. The display is calibrated to dBFS units and features peak hold indicators which stay visible for a short time so you can clearly see the maximum levels reached.

To achieve optimum audio quality, ensure your audio levels do not reach 0 dBFS. This is the maximum level that your camera can record, meaning that any audio that exceeds this level will be clipped, resulting in distortion.



The colored bars on the audio meter represent peak audio levels. Ideally your peak audio levels should fall in the upper end of the green zone. If your peaks enter into the yellow or red zones your audio is in danger of clipping.

You can tap the audio meter to bring up volume controls for audio input channels 1 and 2, as well as headset or speaker volume.



Tap the audio meters on your URSA Mini LCD touchscreen to easily access volume and headset or speaker settings

## Focus Zoom

You can magnify any part of your URSA Mini's preview image by double tapping the LCD touchscreen in the location you would like to zoom. You can move the magnified image by dragging your finger around the touchscreen. This is very helpful when checking focus. To return to the standard magnification, double tap on the touchscreen again.

When you have 'focus zoom' enabled on URSA Mini Pro 12K you can also make a pinch to zoom multitouch gesture to adjust the zoom level on the touchscreen. The 'setup' menu on URSA Mini Pro 12K lets you configure a function button as a 'focus zoom' toggle that behaves like a double tap on the touchscreen. This can be configured to show on the LCD or the front or main SDI to outputs. For information on how to configure a function button as 'focus zoom', see the 'Function Button Behaves as Preset or Toggle' section.





While zoomed in, an indicator in the top left of your LCD touchscreen will show which part of the image you are viewing. You can move around the image by dragging your finger along the screen as you would on a smartphone or tablet

## Full Screen Mode

It can be useful when framing or focusing a shot to temporarily hide your touchscreen's status text and meters. Simply swipe up or down on URSA Mini's LCD touchscreen to hide these. The record indicator, frame guides, grids, focus assist and zebra will remain visible.

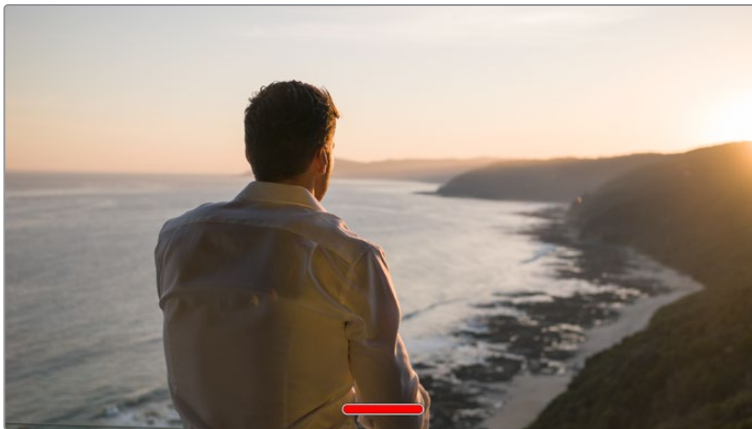

Swipe up or down to hide all status indicators on your URSA Mini LCD touchscreen

## Playback Menu

Tap the 'play' control button to access the playback menu. You can control previously recorded clips with your camera's control buttons or the LCD touchscreen.

When using the LCD touchscreen, tap 'play' once to start playback and again to pause. Use the forward and reverse buttons to skip to the start or end of clips. Tapping 'forward' once moves you to the next clip. Press the reverse button once to go to the start of the current clip or press twice to skip back to the start of the previous clip. Playback of clips can also be looped by activating the loop icon.



The reverse, play, forward and loop icons

To shuttle, hold down either the forward or reverse transport buttons. This will play your footage back at twice regular speed in either forward or reverse, depending on which transport key you held.

Once shuttling, you can change the shuttle rate by tapping the transport keys again. Each time you tap the transport key in the same direction you will double the shuttle rate. The maximum shuttle rate is x16 normal speed. Tapping the transport key again at x16 speed will return you to x2 speed. Tapping the opposite direction will halve the current shuttle speed until you reach 2x speed. You can return to normal playback by tapping the 'play' button.



The shuttle speed indicator displays the speed and direction of footage being fast forwarded or reversed

Tapping the 'record' control button in playback mode will return your camera to standby mode, ready to record.

**TIP** Swipe up or down on your URSA Mini's touchscreen to hide status text while playing back footage. Entering the slate in playback mode will allow you to mark the current clip 'good take' in metadata. For more information, see the 'entering metadata' section in this manual.

## Settings

### Dashboard

Pressing the 'menu' control button on your URSA Mini will bring up your camera's dashboard. This is a tabbed menu containing the settings not available from your URSA Mini's head up display. Settings are divided by function into 'record,' 'monitor,' 'audio,' 'setup,' 'presets,' and 'LUTS' tabs. Some tabs, such as 'record,' 'monitor,' and 'setup' contain multiple pages. You can cycle between these pages by tapping the arrows on the left and right of the settings screen, or swiping left or right as you would on a smartphone or tablet.

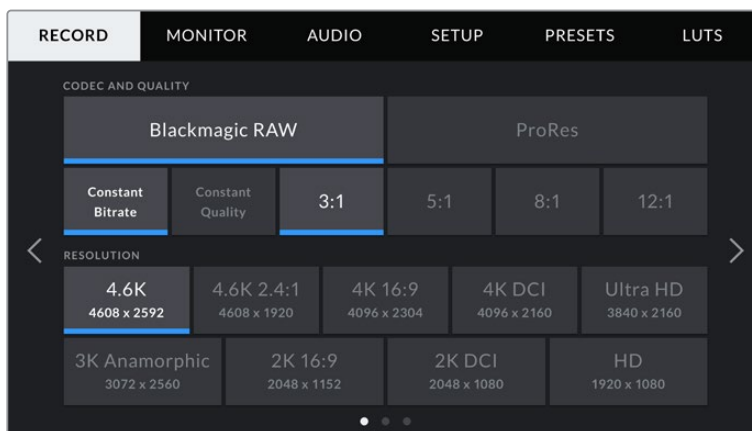

Tap the 'record,' 'monitor,' 'audio,' 'setup,' 'presets,' and 'LUTS' headings to move between your URSA Mini's dashboard tabs

**NOTE** On URSA Mini Pro 4.6K, the camera dashboard times out after one minute of inactivity, returning you to the heads up display.

## Record Settings

The 'record' tab allows you to set your video format, codec, and resolution, as well as other settings which affect the footage saved by your URSA Mini, such as preferred card and detail sharpening. This menu has three pages, which you can cycle through by tapping the arrows at the edge of your camera's touchscreen, or swiping left or right.

### Record Settings 1

The first page of the 'record' settings tab contains the following settings.

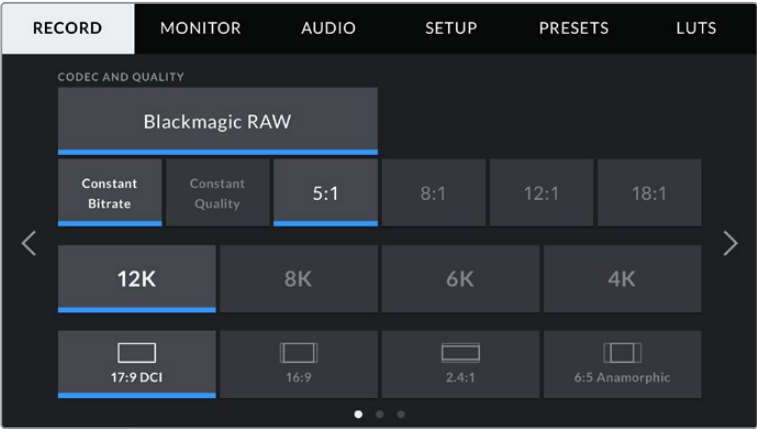

The first page of 'record' settings on URSA Mini Pro 12K

### Codec and Quality

URSA Mini Pro 12K records Blackmagic RAW at 12K, 8K, 6K and 4K resolutions. Each resolution has a menu to support a range of industry standard aspect ratios.



Resolution and aspect ratio options on URSA Mini Pro 12K

On URSA Mini Pro 4.6K G2 and URSA Mini Pro 4.6K cameras, the 'codec and quality' menu is split into two rows. You can select Blackmagic RAW or Apple ProRes. The bottom row offers quality options within those families. Blackmagic RAW options are divided between 'constant bitrate' and 'constant quality' settings. The quality options available within the ProRes codec family include 444, HQ and LT. URSA Mini supports a wide range of ProRes codecs.

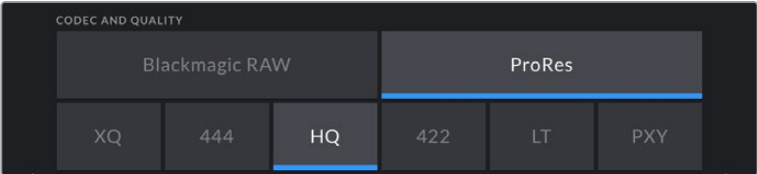

'Codec and quality' options on URSA Mini Pro 4.6K G2 and URSA Mini Pro 4.6K cameras

**TIP** The amount of video you can record on your camera's storage media increases when choosing codecs that utilize higher compression. Refer to the 'record duration table' in the 'recording' section for more information.

**Resolution**

This setting works in combination with the 'codec' setting. Use it to select the resolution for your desired recording format.

For example, if you want to record Ultra HD clips using ProRes HQ, select 'ProRes' and 'HQ' in the 'codec and quality' menu. Now choose 'Ultra HD' in the resolution menu.

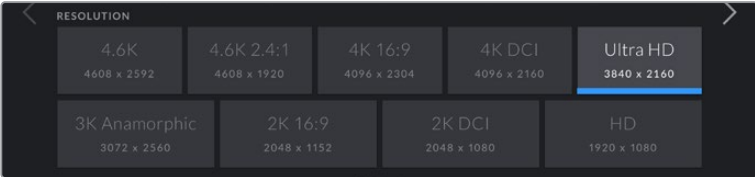

'Resolution' options on URSA Mini Pro 4.6K G2 and URSA Mini Pro 4.6K cameras

**NOTE** Blackmagic URSA Mini 4.6K and URSA Mini Pro support a wide range of Apple ProRes resolutions from 4.6K down to HD.

**Record Settings 2**

The second page of the 'record' settings tab contains the following settings.

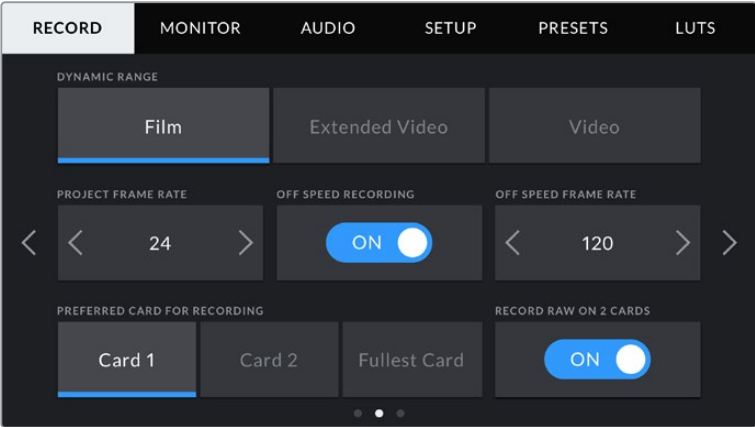

URSA Mini Pro 12K has a setting for 'record RAW on 2 cards'. This option is disabled on other URSA Mini cameras.

**Dynamic Range**

Adjust the 'dynamic range' setting by tapping the dynamic range icons. Blackmagic URSA Mini has two dynamic range settings:

**Film**

The 'film' setting shoots video using a log curve giving you 12 to 15 stops of dynamic range, depending on your URSA Mini model, and maximizes the information in your video signal to help you get the most out of color grading software, such as DaVinci Resolve.

## Video

The 'video' setting is similar to the REC 709 color standard for high definition video. This lets you work faster by recording directly to the compressed video formats in a color space suitable for direct delivery or minimal post processing.

URSA Mini Pro has an additional setting available:

### Extended Video

The 'extended video' setting offers a good balance between 'video' and 'film' dynamic range settings. This setting offers a wider dynamic range than 'video,' while applying a mild contrast change with a smooth roll off in the highlights. 'Extended video' is suitable for use with standard broadcast monitors and is a helpful setting if you have limited time for post production and want to record your clips with a pleasing 'look' applied.

**NOTE** If you are using 'video' or 'extended video' dynamic range, make sure that display LUT is not enabled on any of the monitor outputs, LCD, Front SDI or Main SDI. If the display LUT is enabled, the LUT indicator will be visible on the HUD and the image appears to have more saturation and contrast than intended. To check your display LUTs setting, see the 'monitor' settings later in this manual.

## Window Sensor

URSA Mini Pro 12K manages sensor windowing automatically. It uses a windowed sensor when shooting 6K Super 16 and 4K Super 16, and uses the full height or width of the Super 35 sized image sensor in all other shooting modes.

It's important to note that on URSA Mini Pro 12K, 6K Super 16 windows the frame dimensions to a Super 16 crop, however with 6K resolution the crop will still provide amazing image quality. 4K Super 16 uses the same Super 16 window and downscales the result to 4K. This means you can shoot at the highest frame rates and still have spectacular 6K or 4K image quality. The 12K sensor with a Super 16 crop means you can also mount vintage Super 16mm lenses and shoot at 4K or 6K resolution which is arguably higher than the original Super 16mm film quality.

Other URSA Mini Pro cameras can be set to use the 'full' sensor area. Alternatively, for even higher frame rates you can use 'window' mode. This will use only the amount of sensor pixels needed for a given video format rather than downscaling images from the entire sensor.

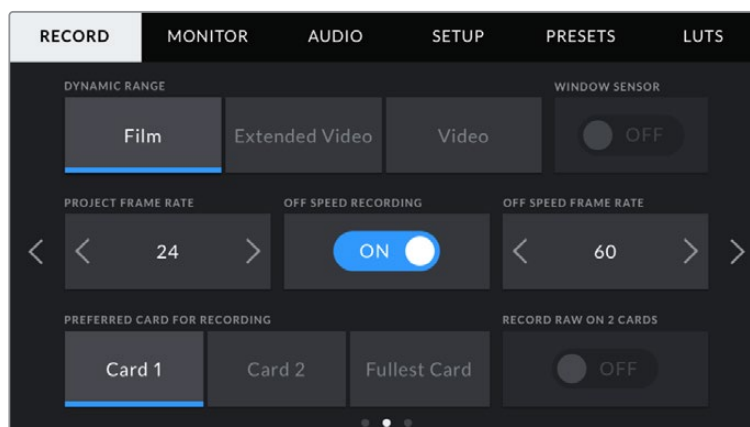

The 'window sensor' option on URSA Mini Pro 4.6K G2, URSA Mini Pro 4.6K, URSA Mini 4.6K and URSA Mini 4K

As the HD 'window sensor' and 2K 'window sensor' modes use only the very center of URSA Mini's sensor, the field of view of any given lens will appear narrower due to the crop factor involved. When using a 20mm lens to shoot HD footage in windowed sensor mode, for instance, field of view of URSA Mini will be equivalent to a 48mm lens.

This setting is available when shooting below your URSA Mini's maximum resolution. For example, 'window sensor' is available when shooting 4.6K 2.4:1, 4K, 3K anamorphic, 2K or HD ProRes footage on URSA Mini 4.6K.

The fastest frame rates are available when shooting HD footage in windowed mode.

**TIP** When using 'window sensor' mode, your URSA Mini's 'resolution' settings will be labelled 'resolution - sensor windowed' to reflect this.

### Project Frame Rate

The project frame rate is URSA Mini's recording format frame rate and provides a selection of common frame rates used in the film and television industry. For example, 23.98 frames per second using 4K ProRes HQ. This frame rate is normally set to match your playback speed and audio sync used in your post production workflow and delivery requirements.

Your Blackmagic URSA Mini has 8 project frame rate settings including 23.98, 24, 25, 29.97, 30, 50, 59.94 and 60 frames per second.

**NOTE** Your camera's project frame rate has a large impact on the 'look' of footage.

High frame rates such as 50, 59.94 or 60 frames per second are great for capturing smooth motion and eliminate or minimize stutter while panning.

Lower frame rates, such as 24 or 25 frames per second, are typically used for cinema production. These have a distinct filmic 'look,' but require much slower camera movement to avoid stutter.

### Off Speed Recording

By default, your URSA Mini's project and sensor frame rates are matched for a natural playback speed. However, by tapping the 'off speed recording' switch icon you can set your sensor frame rate independently.

### Off Speed Frame Rate

With 'off speed frame rate' enabled, tap the arrows next to the 'off speed frame rate' indicator to set your URSA Mini's sensor frame rate.

The sensor frame rate sets how many actual frames from the sensor are recorded every second. This frame rate will affect how fast or slow your video will play back at your set project frame rate.

For more information on off speed frame rates, see the 'frames per second' section in the 'touchscreen features' section of this manual.

**NOTE** For information on the maximum frame rates available for each recording format and codec, refer to the 'maximum sensor frame rates' table in the 'recording' section of this manual.

### Preferred Card for Recording

Use this setting to select which storage card or drive your URSA Mini will record to first when both slots are in use. The options are 'card 1,' 'card 2,' and 'fullest card'. When using an SSD the options will be 'card 1,' 'SSD' and 'fullest card'. Picking either 'card 1' or 'card 2,' is a matter of personal preference, but using either consistently will let you know which card to swap out first as your storage fills up. 'Fullest card' can help group files chronologically when shooting a single camera project.

The setting you choose is applied when a CFast card, SD card or SSD is inserted. You can override this setting at any time by entering the storage manager and setting a different card as 'active.' It's important to note, however, that ejecting and reinserting cards will revert to the current 'preferred card for recording' setting. When URSA Mini Recorder is connected and an SSD is loaded, the recorder takes over from URSA Mini's number '2' storage slot.

For more information refer to the 'URSA Mini Recorder' section in this manual.

**TIP** The 'fullest card' setting is based on the percentage that your storage cards are filled, rather than their sizes or the amount of data used.

### Record RAW on 2 Cards

URSA Mini Pro 12K can record Blackmagic RAW to two cards at the same time. This lets you record extremely high resolution clips at high frame rates with lower levels of compression. Insert a pair of CFast or SD Cards and switch on the 'record RAW on 2 cards' option in the 'record' menu. Since this relies on striping across both cards sequentially, the data rate of the slowest card will be the limiting factor, so you are advised to use two cards of the same or similar spec. You can also stripe between a CFast card in storage slot 1 and a USB-C disk in storage slot 2. When you use the 'Record RAW on 2 Cards' option, the speed limit is twice the data rate of the slowest card in the striped array. Copy the .BRAW and .BRAW2 files from both memory cards into the same folder on your computer, and DaVinci Resolve will bring them in as a single, merged clip when you import them into your media pool. If the .BRAW and .BRAW2 files are separated, the clips can play independently at half the frame rate.

### Record Settings 3

The third page of the 'record' settings tab contains the following settings.

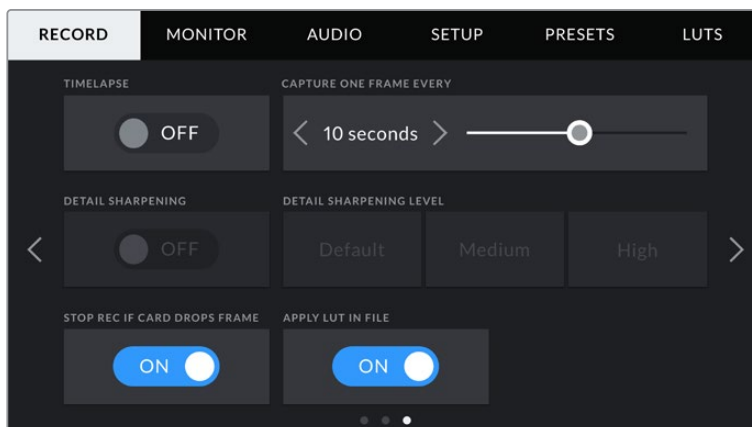

## Timelapse

This setting activates the time lapse feature to automatically record a still frame at the following intervals:

<b>Frames</b>	2 - 10
<b>Seconds</b>	1 - 10, 20, 30, 40, 50
<b>Minutes</b>	1 - 10

For example, you can set the camera to record a still frame every 10 frames, 5 seconds, 30 seconds, 5 minutes etc.

The time lapse feature offers many creative options. For example, setting a 2 frame time lapse interval will give your recorded video a high speed effect when played back.

The format of each still frame is based on your recording format, so if you set the camera to record in 4K ProRes HQ, the time lapse setting will maintain this format. The frame rate will be based on your project frame rate setting, i.e., 24 fps. This is so your time lapse footage can be easily incorporated into your post production workflow.



Your URSA Mini will indicate it is in time lapse mode with an icon over the 'record' button

**TIP** When you record footage in time lapse mode, the timecode counter updates when a frame of video is recorded.

## Detail Sharpening

Use this setting to sharpen your URSA Mini's image. Detail sharpening is available on URSA Mini Pro 4.6K G2, URSA Mini Pro 4.6K, URSA Mini 4.6K and URSA Mini 4K. When sharpening is enabled, decrease or increase the level of sharpening by selecting 'default', 'medium' or 'high'.

When sharpening is enabled, it will be applied to ProRes video recorded on camera as well as your URSA Mini's SDI output. When URSA Mini Pro G2 is set to Blackmagic RAW and is used in conjunction with an ATEM switcher, the detail sharpening function can be applied to your SDI output. This can be switched on or off using the ATEM Camera Control Panel or ATEM Software Control.

This setting is intended for live studio production where there is no time for post production and you want to output the image live to air. We recommend leaving it 'off' for images you are recording for further post production. For this reason, sharpening is not applied to Blackmagic RAW files that are intended for significant post processing.

## Stop Rec If Card Drops Frames

Use this setting to configure your URSA Mini's behavior when dropped frames are detected. When set to 'off,' recording will continue with dropped frames. When set to 'on,' your camera will stop recording if dropped frames are detected. This can prevent you wasting time shooting unusable footage if you don't spot the dropped frame indicator.



**TIP** Refer to the 'choosing a CFast 2.0 card', 'choosing a fast SD card' and 'choosing a fast SSD' sections for more information on how to avoid dropping frames.

### Apply LUT in File

If you are applying a LUT to any of the outputs from your Blackmagic URSA Mini Pro 4.6K, the selected LUT will be embedded into the Blackmagic RAW file you are recording.

This means that the LUT will be saved in the header of the file and can easily be applied to the clip in post production without needing to handle a separate file. When the 'apply LUT in file' switch is set to 'on' in URSA Mini Pro's record menu, this clip will open in Blackmagic RAW Player and DaVinci Resolve with the chosen LUT already applied to it. The LUT can then be easily toggled 'on' or 'off' but will always travel with the Blackmagic RAW file as it is written into the clip itself.

DaVinci Resolve also has an 'Apply LUT' switch in the RAW settings palette for enabling or disabling the 3D LUT in the Blackmagic RAW file. The 'Apply LUT' setting in DaVinci Resolve is the same setting as in the camera. This means that when shooting you can direct the colorist to use the LUT by setting it in the camera, but they can switch it off easily in DaVinci Resolve by setting 'Apply LUT' to 'off'.

## File Naming Convention

Clips are recorded to your CFast card, SD card or SSD in .braw file format when recording Blackmagic RAW, or to a ProRes QuickTime movie depending on which recording format you have chosen.

The table below shows an example of the file naming convention:

<b>A001_08151512_C001.mov</b>	<b>QuickTime Movie Filename</b>
A001_08151512_C001.mov	<b>Camera index</b>
A <b>001</b> _08151512_C001.mov	<b>Reel Number</b>
A001_ <b>08</b> 151512_C001.mov	<b>Month</b>
A001_08 <b>15</b> 1512_C001.mov	<b>Day</b>
A001_0815 <b>15</b> 12_C001.mov	<b>Hour</b>
A001_081515 <b>12</b> _C001.mov	<b>Minute</b>
A001_08151512_ <b>C001</b> .mov	<b>Clip Number</b>

Still image files captured using the still button will follow the file naming convention for video clips, however the filename will have an 'S001' representing the 'still number' as the last four digits of the filename in place of the clip number. URSA Mini Pro 12K records stills as a single Blackmagic RAW frame. URSA Mini Pro 4.6K G2 and URSA Mini Pro 4.6K record stills as a DNG file to the stills folder. For more information, refer to the 'Status LCD Controls' section in this manual.

## Monitor Settings

The 'monitor' tab lets you adjust status text, overlays, and other monitoring options for your URSA Mini's LCD touchscreen, front and main SDI outputs. Options are arranged by output between 'LCD', 'front SDI' and 'main SDI', as well as 'all,' which covers monitor settings that affect all outputs on your URSA Mini. Each of these menus has two pages of options, which you can cycle through by tapping the arrows at the edge of your camera's touchscreen, or swiping left or right.

### LCD, Front SDI, Main SDI Monitor Settings 1

The first page of the 'LCD,' 'front SDI,' and 'main SDI,' monitor tab contains identical settings for each output. For example, you can set 'zebra' on for the LCD touchscreen, but off the front or main SDI outputs.

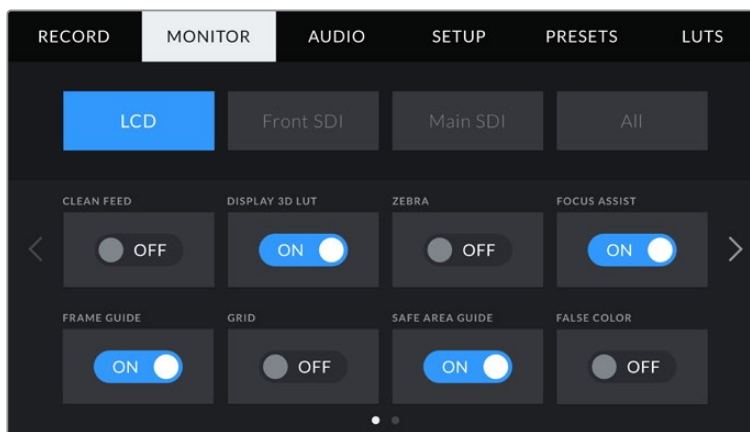

### Clean Feed

Tap the 'clean feed' switch in the 'LCD,' 'front SDI' and 'main SDI' menus to disable all status text and overlays for that output, except the record tally indicator.

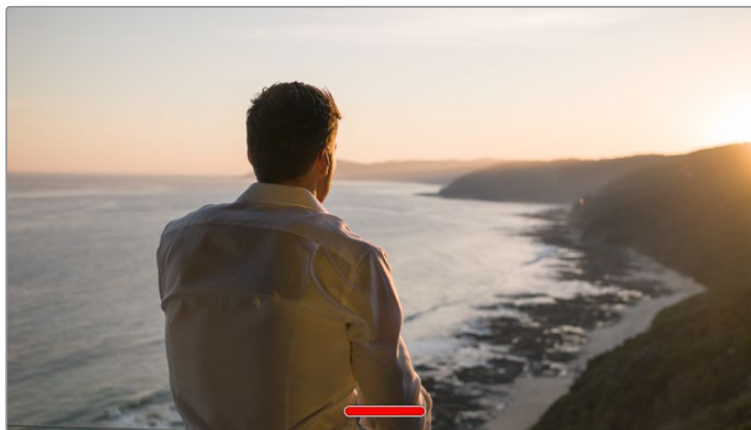

Your URSA Mini LCD touchscreen will still display a record tally in clean feed mode

**NOTE** LUTs will still be applied to outputs with 'clean feed' enabled. To disable LUTS, disable the 'display LUT' switch in the 'Monitor' menu for that output.

### **Display 3D LUT**

Your URSA Mini can apply 3D LUTs to any output to approximate the look of color graded footage. This is especially useful when shooting with 'film' dynamic range, as it can produce an intentionally 'flat' low contrast image.

If your URSA Mini has a 3D LUT active, use this setting to independently apply that LUT to your LCD touchscreen, front or main SDI output.

**NOTE** For more information on loading and using 3D LUTs, see the 'LUTS' section of this manual.

### **Zebra**

Tap the 'zebra' switch in the 'LCD,' 'front SDI' and 'main SDI' menus to enable zebra guides for those outputs. For more information on zebra guides and setting zebra levels, see the 'touchscreen features' section in this manual.

### **Focus Assist**

Tap the 'focus assist' switch in the 'LCD,' 'front SDI' and 'main SDI' menus to enable focus assist for those outputs. For more information on focus assist and setting focus assist levels, see the 'touchscreen features' section in this manual.

### **Frame Guide**

Tap the 'frame guide' switch in the 'LCD,' 'front SDI' and 'main SDI' menus to enable frame guides for those outputs. For more information on frame guides and choosing different guides, see the 'touchscreen features' section in this manual.

### **Grid**

Tap the 'grid' switch in the 'LCD,' 'front SDI' and 'main SDI' menus to enable a rule of thirds grid for those outputs. For more information on the rule of thirds grid, see the 'touchscreen features' section in this manual.

### **Safe Area Guide**

Tap the 'safe area' switch in the 'LCD,' 'front SDI' and 'main SDI' menus to enable safe area overlay for those outputs.

For more information on safe area guides, and setting the level of safe area guides, see the 'touchscreen features' section in this manual.

**NOTE** Use the 'safe area guide %' setting in your URSA Mini's 'all' monitoring settings to set the size of the safe area guide.

### **False Color**

Tap the 'false color' switch in the 'LCD,' 'front SDI' and 'main SDI' menus to enable false color exposure assistance for those outputs.

For more information on false color, see the 'touchscreen features' section in this manual.

## LCD Monitor Settings 2

The second page of your URSA Mini's 'LCD' monitor tab contains settings unique to your LCD touchscreen.

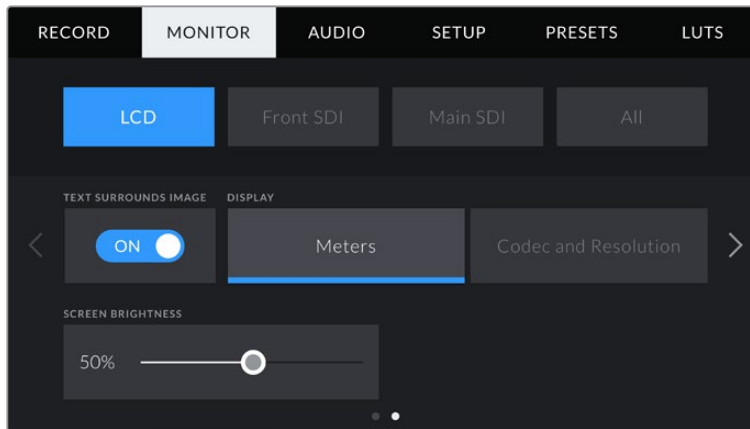

### Text Surrounds Image

This setting is available on URSA Mini 4K and URSA Mini 4.6K models only. Tap the 'text surrounds image' switch in the 'LCD' menu to scale the image on your LCD touchscreen down 75%. This puts the image in the center of the LCD touchscreen away from status indicators at the top and bottom edges, giving you an unobstructed view of your URSA Mini's preview image while keeping status text on screen.



'Text surrounds image' gives you a clear view of your URSA Mini EF or PL's preview image for framing purposes while keeping status text on screen

### Status Text On/Off

This setting is only available for URSA Mini Pro. It can be useful to hide the status text and meters on your LCD HUD, leaving only the information necessary to compose or direct a shot. Tap the 'status text' switch icon to toggle the appearance of status text and meters for URSA Mini Pro's LCD touchscreen. Overlays such as frame guides, grids, focus assist and zebra will remain visible, if enabled. Swiping up or down on your URSA Mini Pro's LCD touchscreen has the same effect.

## Display

Instead of a histogram and audio meters, your URSA Mini can display codec and resolution information at the left and right bottom edges of the LCD touchscreen. This can be useful if you prefer to use false color for dialling in exposure, or are recording audio separately and want to display additional information in the space normally used by the histogram and audio meter.

Simply tap 'meters' or 'codec and resolution' in the 'LCD' menu to select your preferred view.

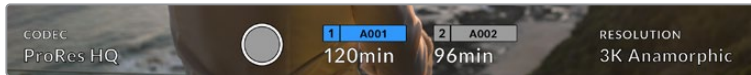

Your URSA Mini can display codec and resolution information in place of the histogram and audio meters

## Screen Brightness

Drag the 'screen brightness' slider in the 'LCD' menu left or right to adjust the brightness of your URSA Mini's LCD touchscreen.

## Front SDI and Main SDI Monitor Settings 2

The second page of your URSA Mini's 'front SDI' and 'main SDI' monitor tab contains settings unique to your front and main SDI outputs.

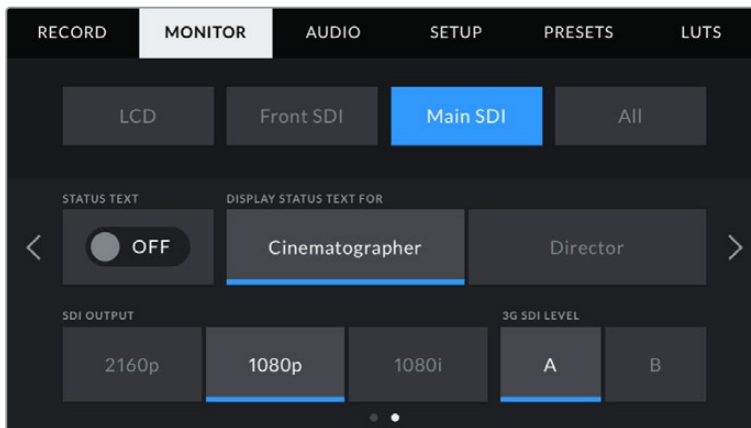

2160p and 1080p resolutions are available on your main SDI output as all times when shooting at resolutions above 3K anamorphic. 1080i is only available for your camera's main or front SDI output when shooting at frame rates of 50, 59.94, or 60. '3G SDI level' is available on URSA Mini Pro 4.6K G2 only

## Status Text

It can be useful to hide the status text and meters on your front SDI or main SDI output, leaving only the information necessary to compose or direct a shot. Tap the 'status text' switch icon in the 'front SDI' or 'main SDI' monitor menus to toggle the appearance of status text and meters for that output. Overlays such as frame guides, grids, focus assist and zebra will remain visible, if enabled.

Swiping up or down on your URSA Mini's LCD touchscreen has the same effect for the touchscreen.

## Display Status Text For Cinematographer or Director

Your URSA Mini's LCD touchscreen displays information such as ISO, white balance, and aperture that is useful to a camera operator or cinematographer setting up individual shots on that camera. URSA Mini's front and main SDI outputs, however, can also show information useful to a director or script supervisor who is keeping track of multiple shots or cameras.

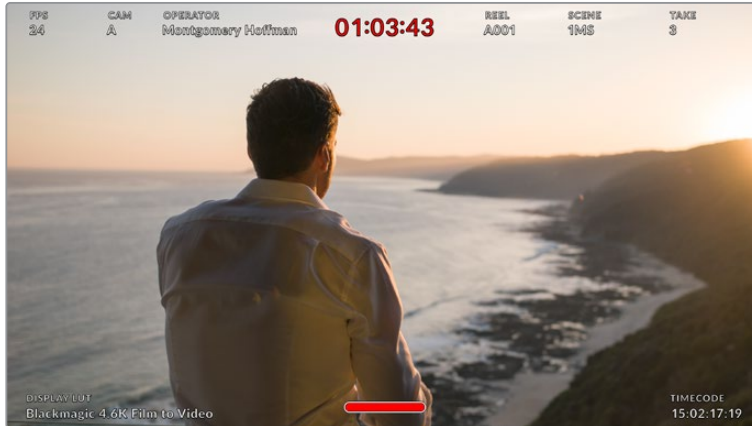

Your URSA Mini can display director specific status text on its front and main SDI outputs

Setting the status text to 'director' in your URSA Mini's 'front SDI' or 'main SDI' monitor settings changes the status text for that output to show the following information.

### FPS

Displays the currently selected frames per second for that camera. If off speed frame rate is disabled, only the project frame rate will be shown. If an off speed frame rate is being used, the sensor frame rate will be shown, followed by the project frame rate.

### CAM

Displays the camera index as set in your URSA Mini's Slate. See the 'slate' section later in this manual for more information.

### OPERATOR

Identifies the camera operator as set in your URSA Mini's Slate. See the 'slate' section later in this manual for more information.

### DURATION DISPLAY

Displays the duration of the current clip, while recording, or the last recorded clip in the following format: hours:minutes:seconds

### REEL, SCENE, TAKE

Displays the current reel, scene and take. For more information on reels, scenes, takes and their labelling conventions, refer to the 'slate' section later in this manual.

### DYNAMIC RANGE

The bottom left hand corner of the monitor displays your URSA Mini's currently applied LUT, if applied to that output. If no LUT is applied, 'film' or 'video' dynamic range will be displayed.

### TIMECODE

The bottom right of the monitor displays your URSA Mini's timecode, in the following format: hours:minutes:seconds:frames

## SDI Output

Both outputs allow you to choose between progressive and interlaced HD output, while your URSA Mini's main SDI output also has the option of progressive Ultra HD.

The options available in this setting depend on your camera's resolution and frame rate settings.

Progressive HD, or '1080p' is always available regardless of your recording resolution and frame rate, while interlaced HD, or '1080i' is available when your project frame rate is set to 50, 59.94 or 60.

Ultra HD SDI output, or '2160p' is available on your URSA Mini's main SDI when shooting at Ultra HD resolutions.

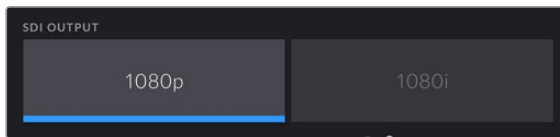

SDI Output – front SDI

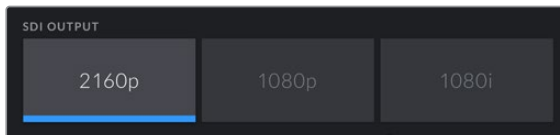

SDI Output – main SDI

## 3G SDI Level

On URSA Mini Pro you can change the 3G-SDI output standard to maintain compatibility with equipment that can only receive level A or level B 3G-SDI video. This option will only appear when you are operating in 50, 59.94 or 60 frames per second and outputting 1080p. Tap the A or B icon to select each standard.

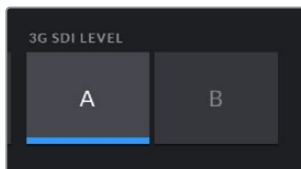

On URSA Mini Pro 4.6K G2, select level A or level B for your 3G-SDI output standard

## All Monitor Settings 1

Monitor settings that affect all of your URSA Mini's outputs are grouped within the 'all' menu. For example, setting 'safe area guide %' to 90% in this menu will set the safe area guide to 90% for your camera's LCD, front SDI and main SDI outputs.

There are two pages of 'all' settings. The first page of your URSA Mini's 'all' monitor tab contains the following settings.

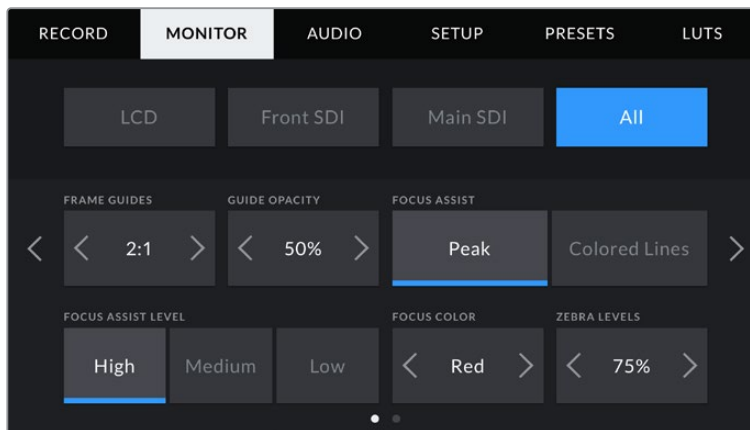

### Frame Guides

Tap the left or right arrows in the 'frame guides' menu setting to cycle through frame guide options for all outputs on your URSA Mini, including EVFs such as Blackmagic URSA Viewfinder. The options are detailed in the 'touchscreen features' section of this manual, and are also accessible from the LCD monitoring menu in your LCD touchscreen head up display. It's worth noting that you can individually select whether frame guides will appear on your LCD touchscreen, front SDI and main SDI output in their respective 'monitor' menus.

### Guide Opacity

Tap the left or right arrows in the 'guide opacity' menu setting to choose the opacity of the areas blocked out by frame guides on your LCD touchscreen, front and main SDI outputs. The options are 25%, 50%, 75% and 100%.

### Focus Assist

Your URSA Mini camera has two focus assist modes, 'peak' and 'colored lines.'

#### Peak

When 'peak' style focus assist is selected, areas of the shot that are in focus are heavily sharpened on your LCD touchscreen or SDI outputs, but not in the recorded image itself. This causes focused parts of your shot to 'pop' out of the softer background on screen. As no additional overlays are used, this can be a very intuitive way to tell when focus is dialled in, especially when the subject you're focusing on is physically well separated from other elements in shot.

#### Colored Lines

When 'colored lines' style focus assist is selected, a colored line is superimposed around the parts of the image that are in focus. This can be a little more intrusive than 'peak' style focus assistance as the lines are drawn over your image, but especially in busy shots with a lot of visible elements, it can be a precise focus aid.

### Focus Assist Level

To set the level of focus assistance for your LCD touchscreen, front SDI and main SDI, tap the 'low,' 'medium' or 'high' setting.

**NOTE** Setting the focus assist level does not affect whether focus assistance is enabled on your URSA Mini's LCD touchscreen or SDI outputs. You'll still need to turn focus assistance on individually for each output in the 'LCD,' 'front SDI,' or 'main SDI' monitor menus.



**TIP** The optimum level of focus assistance varies shot by shot. When focusing on actors, for example, a higher level of focus assistance can help resolve edge detail in faces. A shot of foliage or brickwork, on the other hand, may show distracting amounts of focus information at higher settings.

### Focus Color

Use this setting to change the color of focus line overlays when using 'colored lines' style focus assistance. Changing the focus line color can make it easier to tell focus assistance lines apart from your image. The available options are 'white,' 'red,' 'green,' 'blue' and 'black.'

### Zebra Levels

Set the exposure level that zebra appears at by tapping the arrow icons on either side of this setting. Zebra level is adjustable in five percent increments between 75 and 100 percent exposure.

For more information, see the 'zebra' guide in the 'touchscreen features' section of this manual.

### ND Filter indicator

Adjusting your URSA Mini Pro's ND filter will display the ND filter indicator in the top left of the LCD touchscreen and any SDI outputs set to show status text. This indicator will remain on when you have an ND filter engaged. When you have it set to the position where there is no ND filter, the 'clear' text will disappear after four seconds.



Adjusting your URSA Mini Pro's ND filter setting will reveal the ND filter indicator

**NOTE** You can adjust the terminology used by the ND filter indicator to reflect the conventions you're used to. The options are ND number, stops and fractions. You can set your preferred format in your URSA Mini Pro's 'setup' menu.

### LUT indicator

The LUT icon will be visible on the LCD, front SDI or main SDI when 'status text' is switched on and you have a LUT applied to that output.

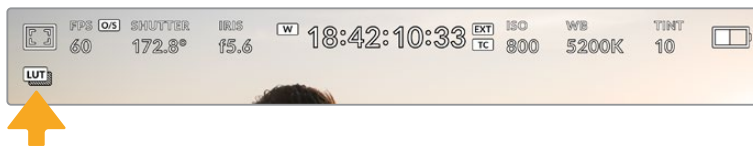

The LUT icon lets you know that you have a LUT applied to the image

## All Monitor Settings 2

The second page of your Ursa Mini's 'all' monitor tab contains the following options:

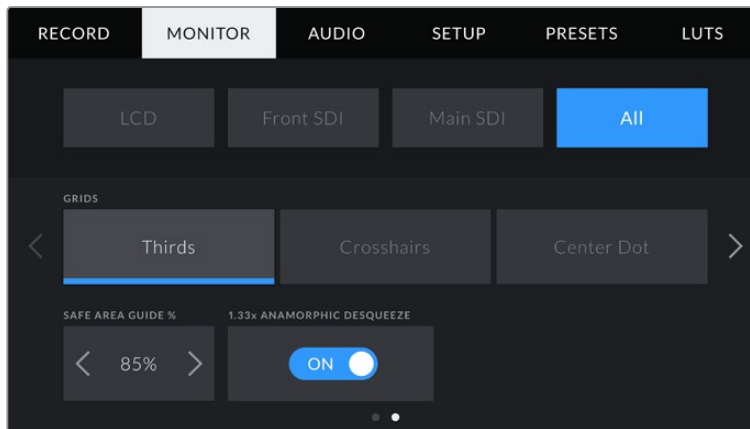

### Grids

To set which combination of grids and crosshairs you want to display on your URSA Mini's LCD touchscreen, front and main SDI outputs, tap the 'thirds,' 'crosshairs,' or 'center dot' options in this setting.

For more information, see the 'grids' guide in the 'touchscreen features' section earlier in this manual.

### Safe Area Guide %

To adjust the size of the safe area overlay on your URSA Mini's LCD touchscreen, front SDI and main SDI outputs, tap the arrows to the left and right of the percentage displayed in this setting. This percentage indicates the size of the safe area in relation to the image frame. Most broadcasters require a 90% safe area.

### Anamorphic Desqueeze

When shooting with anamorphic lenses, the image will appear horizontally 'squeezed' on your URSA Mini's preview outputs and in recorded files. Enabling 'anamorphic desqueeze' will correct the preview image on your URSA Mini as well as recording the desqueeze amount used in the clip metadata for easy correction in post.

The desqueeze amount available will vary depending on what you've set your URSA Mini resolution to, but the resulting image will always be in the cinematic widescreen 2.4:1 aspect ratio.

Anamorphic lenses designed for film typically have a 2x squeeze factor. Your URSA Mini's '3K anamorphic' resolution is designed for use with these lenses and will perform a 2x desqueeze when set to this resolution with 'anamorphic desqueeze' enabled.

Anamorphic lenses designed for 16:9 digital image sensors often use a 1.33x squeeze factor to produce 2.4:1 cinematic widescreen images from the entire 16:9 sensor. Therefore, when your URSA Mini is set to 16:9 resolutions such as '4K 16:9' and 'HD 16:9,' the desqueeze ratio will be 1.33:1.

**TIP** If your image appears horizontally stretched when shooting with a standard spherical lens, make sure you don't have 'anamorphic desqueeze' enabled.

## Audio Settings

The 'audio' tab lets you adjust the audio input and monitoring settings on your URSA Mini. This menu is slightly different between URSA Mini and URSA Mini Pro models, so the available settings are described separately below.

### Audio Settings – URSA Mini

The audio settings for your URSA Mini are divided by audio input source between 'camera' and 'XLR' for onboard and externally sourced audio. 'XLR' settings are spread over two pages, which you can cycle through by tapping the arrows at the edge of the LCD touchscreen or swiping left or right.

#### Camera Audio Settings

When you select 'camera' audio input, your URSA Mini will have one page of audio settings available. The 'camera' audio tab contains the following settings.

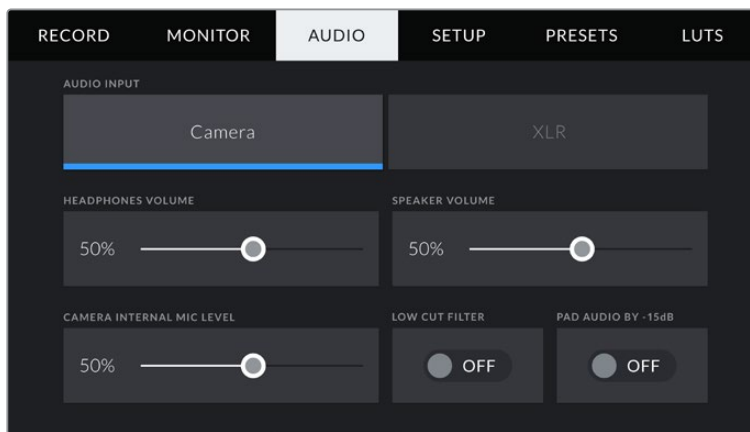

#### Headphones Volume

This slider adjusts the output levels for headphones attached to URSA Mini's 3.5mm headphone jack. Move the audio slider left or right to adjust levels.

#### Speaker Volume

This slider adjusts the output levels for your URSA Mini's built in speaker. Move the audio slider left or right to adjust levels.

#### Camera Internal Mic

This slider adjusts the recording levels for your URSA Mini's built in microphone. Move the audio slider left or right to adjust levels. The built in microphone records to audio channels 1 and 2.

#### Low Cut Filter

Tap this switch icon to enable the low cut filter for your camera's internal microphones. This filter helps to reduce potential wind noise or low frequency rumbling that may occur in exterior shooting conditions. Note that the 'pad audio by -15 dB' selector must be switched off for this function to work.

#### Pad Audio By -15dB

The -15dB pad option gives you added control to further reduce the microphone input gain levels on your URSA Mini's internal microphone when shooting in a loud environment even after your input levels are already turned down.

## XLR Audio Settings 1

When you select 'XLR' audio input, your URSA Mini will have two pages of settings available. The first page of the 'XLR' audio tab contains the following settings.

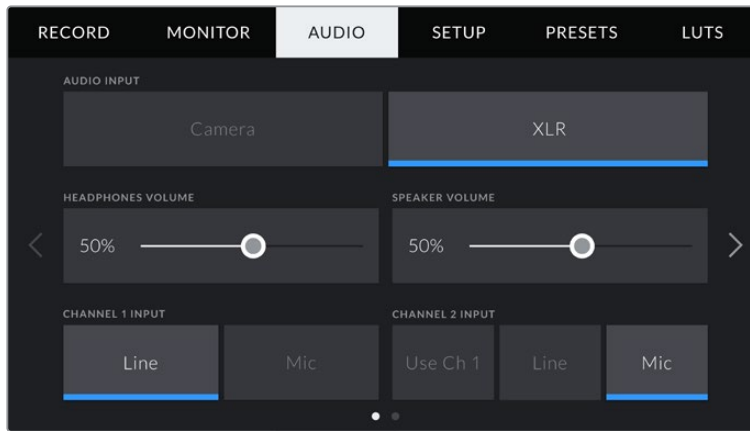

### Headphones Volume

This slider adjusts the output levels for headphones attached to URSA Mini's 3.5mm headphone jack. Move the audio slider left or right to adjust levels.

### Speaker Volume

This slider adjusts the output levels for your URSA Mini's built in speaker. Move the audio slider left or right to adjust levels.

### Channel 1 and 2 input

Set the external audio input levels by tapping 'line' or 'mic' for channels one or two. These correspond to line, or microphone levels with 48V phantom power. It's important to select the appropriate level for your audio signal. You can set these independently for channels one and two.

Channel 2 also has the option of using channel 1's input if you want to record channel 1 external audio to channels 1 and 2.

## XLR Audio Settings 2

The second page of the 'XLR' audio tab contains the following settings.

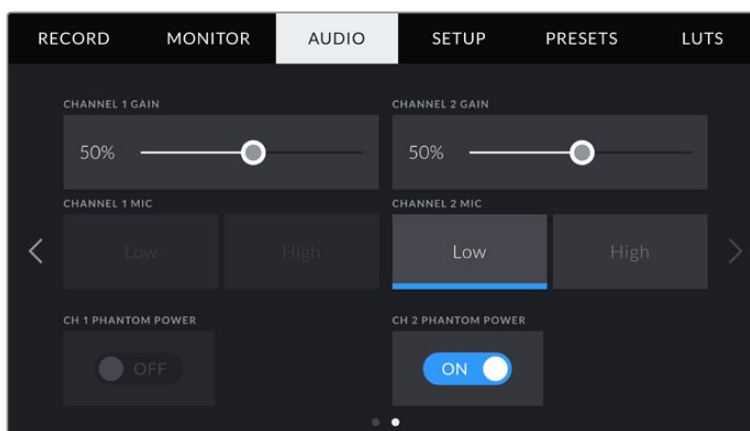

### Channel 1 and 2 gain

Move the slider left and right on the 'channel 1 gain' and 'channel 2 gain' settings to adjust the audio levels for each channel.

### Channel 1 and 2 Mic

The Mic option gives you added control of input gain levels on an external microphone by setting the preamplification level to 'low' or 'high.' The 'low' setting can be useful when shooting in a loud environment even after your input levels have already been turned down.

### Channel 1 and 2 phantom power

Your URSA Mini's XLR inputs can provide 48V phantom power so you can use microphones that aren't self powered. When your camera is set to 'XLR' audio input, simply tap the 'phantom power' switch icon to enable phantom power.

**NOTE** It is standard practice to plug in your XLR cable before switching phantom power on. It is also important to switch phantom power to 'off' when you no longer have a phantom powered microphone connected. Connecting equipment that doesn't require phantom power whilst still in phantom power mode can damage your equipment, as the camera outputs a charge when in this mode. Phantom power can also take quite a while to discharge after switching phantom power off on URSA Mini. Please be aware that you should wait a few minutes when switching off phantom power before plugging in any other microphones or XLR audio equipment.

## Audio Settings – URSA Mini Pro

The audio settings for your URSA Mini Pro are spread over two pages and divided between channels 1 and 2, while an upcoming software update will add two additional channels.

You can map each audio channel to a different source, as well as adjusting various settings such as padding and low cut filters.

These settings work together with the switches on your URSA Mini Pro's internal control panel. So after you've set your audio source for a particular channel, you can use the internal control panel switches to set the signal type and whether phantom power is enabled for that channel.

### Audio Settings 1

The first page of your URSA Mini Pro's 'audio' tab contains the following settings.

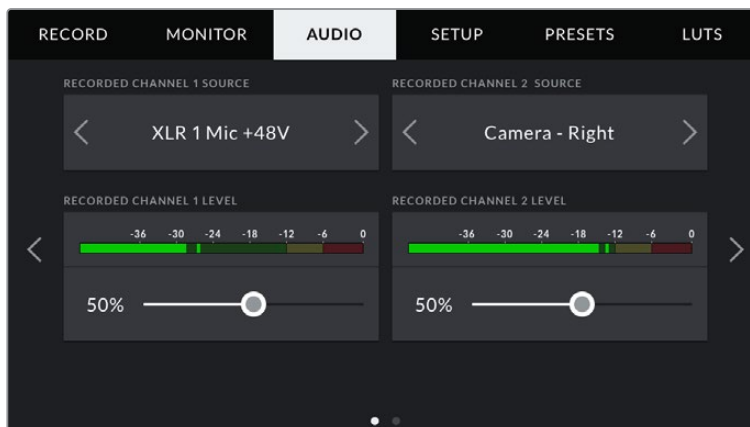

## Channel Source

Use the 'recorded channel 1 source' and 'recorded channel 2 source' buttons to select your audio source for each audio channel. The options are

### Camera Left or Right

Use this setting to record from your camera's internal microphones.

### Camera Mono

Use this setting to record audio from your URSA Mini Pro's built in microphone's left and right channels onto a single audio channel.

### XLR 1 or 2

Use this setting to record from your camera's XLR inputs. Depending on which audio signal you've set on your URSA Mini Pro's internal control panel switches, your XLR input may be listed as 'mic,' 'line,' or 'AES.' If phantom power is enabled and you have your XLR input set to 'mic' you'll also see a '+48V' indicator here. On URSA Mini Pro, it is important to ensure that the 48V switch gets turned 'off' when you disconnect your phantom powered microphone.

### XLR 1 or 2 — Mic Backup

Use this setting to record audio from a microphone plugged into your URSA Mini Pro's XLR 1 or 2 input at a lower level than the standard 'mic' recording. This can be used to avoid audio clipping in the event of an unexpected increase in loudness. This feature will only be available as a selectable item if the XLR 1 or 2 input switch is set to 'mic'.

### None

Use this setting to disable your audio channel.

## Recorded Channel 1/2 Level

Use these sliders to adjust the recording levels of your chosen channel 1 and 2 sources. Audio meters are included with each slider to help you set the correct audio level. These levels will also update when you adjust the audio using the audio knobs on the ergonomic control panel.

To achieve optimum audio quality, ensure your audio levels do not reach 0 dBFS. This is the maximum level that your camera can record, meaning that any audio that exceeds this level will be clipped, resulting in distortion.

## Audio Settings 2

The second page of your URSA Mini Pro's 'Audio' tab contains the following settings

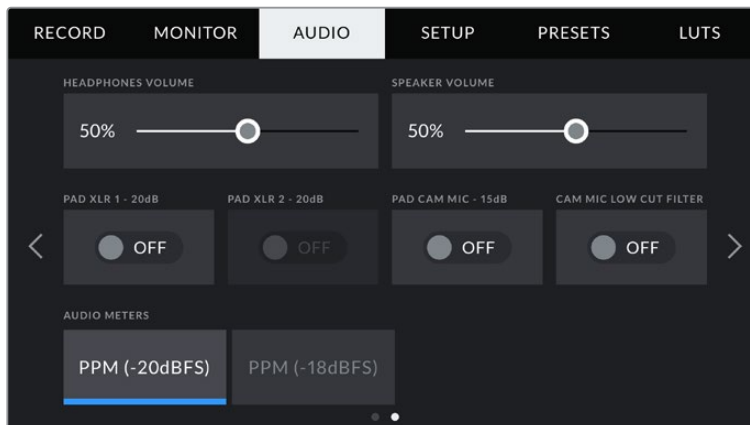

The 'audio meters' setting on URSA Mini Pro 12K and URSA Mini Pro G1

### Headphones Volume

This slider adjusts the output levels for headphones attached to URSA Mini's 3.5mm headphone jack. Move the audio slider left or right to adjust levels. These levels will also update when you adjust the headphone volume using the settings wheel on the forward control panel.

### Speaker Volume

This slider adjusts the output levels for your URSA Mini's built in speaker. Move the audio slider left or right to adjust levels. These levels will also update when you adjust the speaker volume using the settings wheel on the forward control panel.

### Pad XLR -20dB

The -20dB pad option gives you added control to further reduce the input gain levels on your URSA Mini's XLR audio inputs when shooting in a loud environment even after your input levels are already turned down.

### Pad Cam Mic - 15 dB

The -15dB pad option gives you added control to further reduce the microphone input gain levels on your URSA Mini's internal microphone when shooting in a loud environment even after your input levels are already turned down.

### Cam Mic Low Cut Filter

Tap this switch icon to enable the low cut filter for your camera's internal microphones. This filter helps to reduce potential wind noise or low frequency rumbling that may occur in exterior shooting conditions. Note that the 'pad cam mic -15 dB' selector must be switched off for this function to work.

### Audio Meters

Select an 'audio meters' standard for the peak level meters.

Audio meter setting	Standard
PPM (-20 dBFS)	SMPTE RP.0155
PPM (-18 dBFS)	EBU R.68

## Setup Settings

The 'setup' tab contains your URSA Mini's identification settings, software version, function button settings and other camera settings not directly linked to recording or monitoring. You can cycle through pages on the 'setup' tab by tapping the arrows at the edge of the LCD touchscreen, or swiping left or right.

**NOTE** Settings and features shown below may have a slightly different layout on the pages of your URSA Mini's 'setup' tab due to small differences between URSA Mini models. For example, URSA Mini Pro 4.6K G2 has five 'setup' pages and URSA Mini Pro 12K has seven.

Your URSA Mini's 'setup' tab contains the following settings.

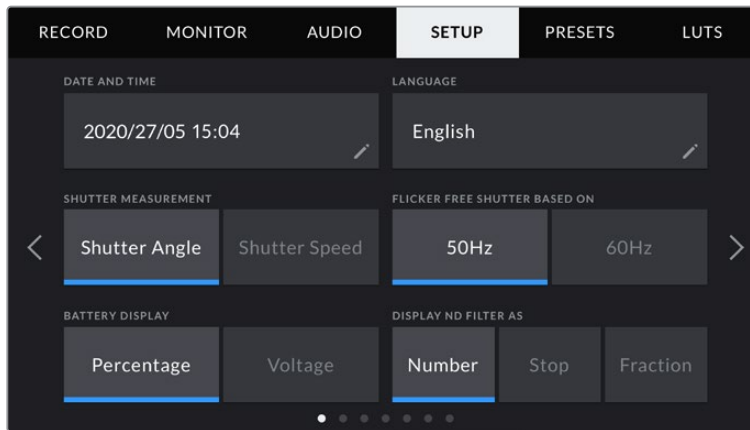

On URSA Mini Pro 12K, URSA Mini Pro 4.6K G2 and URSA Mini Pro 4.6K, the first page of the 'setup' tab has a 'display ND filter as' option. URSA Mini 4.6K and URSA Mini 4K do not have an internal ND filter so this option is unavailable.

### Date and Time

Set your URSA Mini's date and time by tapping the 'date and time' setting. The date format is year, month, day and the time format is 24 hour. Your URSA Mini's date and time are also used for time of day timecode if an external timecode source is not connected.

### Language

English is the only language available currently for URSA Mini Pro 4.6K G2, URSA Mini 4.6K and URSA Mini 4K.

URSA Mini Pro 12K and URSA Mini Pro 4.6K G1 support 11 popular languages including English, Chinese, Japanese, Korean, Spanish, German, French, Russian, Italian, Portuguese and Turkish.

The language page will also appear on initial start up.

#### To select your language:

- 1 Tap on the 'language' and select your language from the list.
- 2 Select 'update' to return to the setup menu.

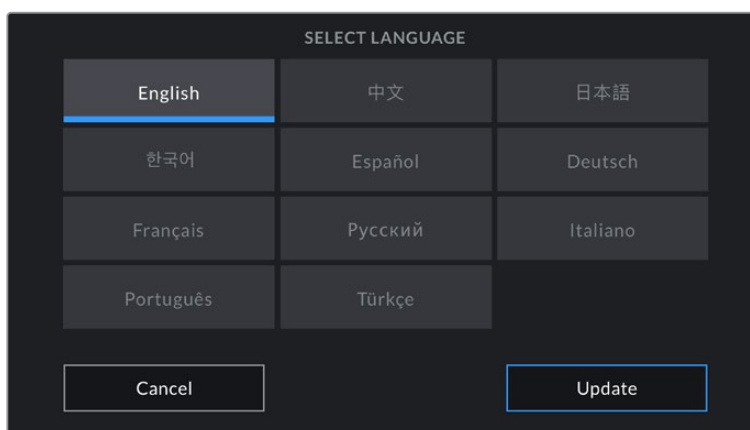

### Shutter Measurement

On URSA Mini 4.6K and URSA Mini Pro, use this setting to select whether to display shutter information as 'shutter angle' or 'shutter speed'.

It's worth mentioning that when using shutter angle, the shutter conforms to the frame rate. For example, 180 degrees will produce the same motion blur, no matter which frame rate you use.



When using shutter speed, however, the shutter is given an absolute value determined independently of the frame rate, so the results will differ if you change the frame rate.

For example, when shooting at 24 frames per second, a 1/48th of a second shutter speed will produce pleasing motion blur at the equivalent of a 180 degree shutter angle. Change the frame rate to 48 frames per second and 1/48th of a second shutter speed no longer offers the same motion blur, now producing the equivalent of a 360 degrees shutter angle. In this example, once the frame rate is changed to 48 fps, you would also need to change the shutter speed to 1/96th of a second to produce the same effect as a 180 degree shutter angle.

### **Flicker Free Shutter Based On**

Use this setting to change the mains power frequency your URSA Mini uses to calculate flicker free shutter settings.

When shooting under lights, your shutter can affect the visibility of flicker. Your URSA Mini will automatically calculate a flicker free shutter value for your current frame rate and display up to three suggested shutter values in your heads up display. Shutter values are affected by the frequency of the local mains power supply used to drive those lights. In most PAL countries, this frequency is 50Hz, while NTSC countries typically use 60Hz power. Simply tap '50Hz' or '60Hz' to set the right frequency for your region.

**NOTE** The characteristics of individual light sources may still cause flicker even when using flicker free shutter values. We recommend always performing a test shoot when not using continuous lights.

### **Battery Display**

Your URSA Mini can change the way the battery level indicator displays the remaining charge. The two settings are 'percentage' and 'voltage.' When using a battery and plates that support percentage accurate levels, setting 'battery display' to 'percentage' will show your battery power remaining as a percentage.

**TIP** A list of batteries that support percentage accurate power information is provided in the 'mounting batteries' section of this manual.

If your battery and plate combination does not support percentage accurate readings, the display will show four bars which empty as the battery depletes.

If this option is set to 'voltage,' battery levels will be displayed in volts. We recommend that you swap the battery as it approaches 12V.

**TIP** You can also toggle between 'voltage' and 'percentage' battery displays by tapping the power icon on the LCD touchscreen.

### **Timecode Drop Frame**

Use the 'timecode drop frame' option to use drop frame timecode when using NTSC project frame rates of 29.97 and 59.94. Drop frame timecode drops a small number of frames from the timecode at set intervals. This keeps your project timecode accurate despite each second not containing a whole number of frames at NTSC frame rates.

### Display ND Filter As

Use this setting to adjust how the ND filter indicator on your URSA Mini Pro displays your ND filter setting. Each setting corresponds to a different camera convention. Cinematographers typically use ND.number notation, while those familiar with DSLRs or broadcast cameras may prefer this information in f-stop format, or as a fraction of available light. These options are available here as 'number,' 'stop,' and 'fraction,' respectively.

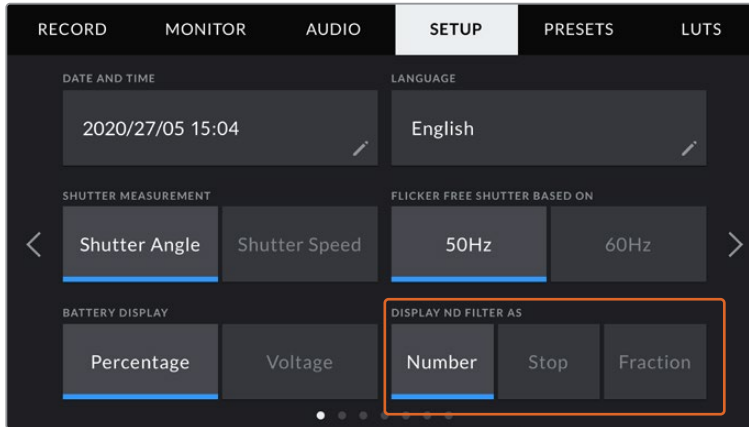

Setup menu in URSA Mini Pro with the option to customize how the ND filter information is displayed

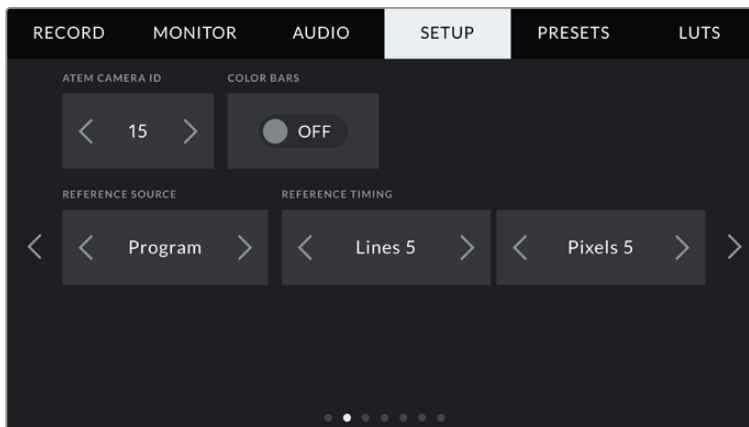

It's worth mentioning that the 'program audio' setting is only available on URSA Mini Pro.

### ATEM Camera ID

If you're using URSA Mini with an ATEM Switcher and want your camera to receive tally signals from the switcher, you'll need to set the camera number on your camera. This ensures the switcher sends the tally signal to the correct camera. The camera number can be set to a value of 1-99 by tapping the left or right buttons. The default setting is 1.

### Color Bars

Outputting color bars rather than a preview image can be useful when connecting your URSA Mini to a switcher or external monitor. The appearance of your URSA Mini's color bars on your switcher or monitor confirms the connection, and you can perform basic monitor calibration based on the colors of the bars. To turn on color bars for all outputs on your URSA Mini, including the LCD touchscreen, simply tap the 'color bars' switch icon.

## Reference Source

This setting is used to select the reference source. Your URSA Mini can lock to an internal or external reference source, or to the reference signal in program input from an ATEM switcher. If you are using your URSA Mini with an ATEM Switcher's camera control function, you should always set your reference source to 'program' unless the switcher itself and all connected cameras are set to an external reference.

**NOTE** When you are setting your reference source for URSA Mini, you may experience a small dropout on your camera's outputs when switching between your reference sources. This is because the camera is adjusting its referencing timing to match that of the external source. For this reason it is important not to change this setting during a production and only while setting up.

## Reference Timing

These settings allow you to manually adjust the reference timing on a line or pixel basis. Simply tap the arrow icons on either side of the 'lines' and 'pixels' settings to make adjustments.

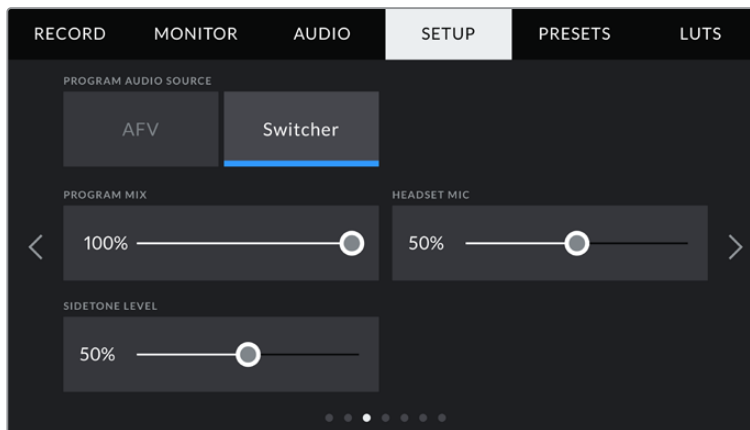

### Program Audio Source

This setting is only available for URSA Mini Pro. When connected to a switcher, setting 'program audio' to 'on' prioritizes the program return audio as your input source to be mixed with talkback when monitoring using headphones or a headset. This is useful when you are not feeding the switcher audio from your camera but you still want to listen to the program feed from the switcher via the 'SDI in' port. Setting 'program audio' to 'off' prioritizes audio from your camera's internal mics or 'audio in' XLR ports, and is the default setting.

### Program Mix

This setting changes the balance of camera sound to talkback sound. The headphones will output audio following what is displayed on the LCD. For instance, if you are in camera view, camera audio is heard. If you are in program view, program audio is heard. The default setting is 100%.

### Headset Mic

Move this volume slider left or right to increase or decrease audio microphone input levels. The default setting is 50%.

### Sidetone Level

Adjust this slider to set the volume of your own voice mic in your headset.

## Set Function Button

On the outside of your URSA Mini's LCD touchscreen, you'll notice two function buttons, 'F1' and 'F2.' These are mappable to frequently used features and are quickly accessible when using your camera with the LCD touchscreen closed, such as when you are using URSA Viewfinder.

On URSA Mini Pro 12K, URSA Mini Pro 4.6K G2 and URSA Mini Pro 4.6K models, you can also map the HFR button to another function or disable it. The default setting for the 'HFR' button is 'off speed rec'.

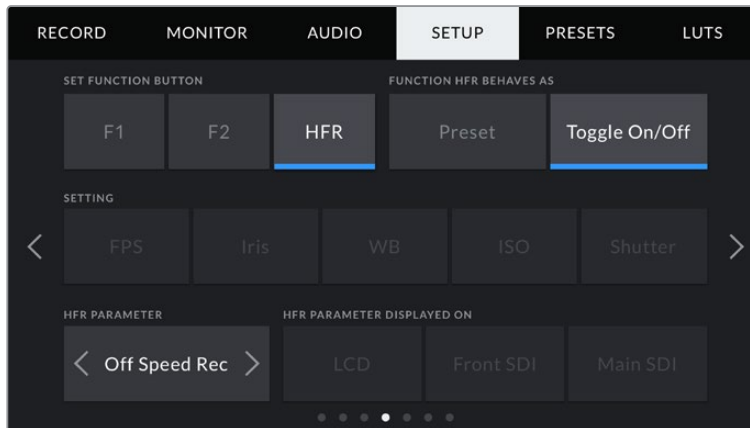

On URSA Mini Pro 12K, URSA Mini Pro 4.6K G2 and URSA Mini Pro 4.6K, the HFR button can be mapped to another function

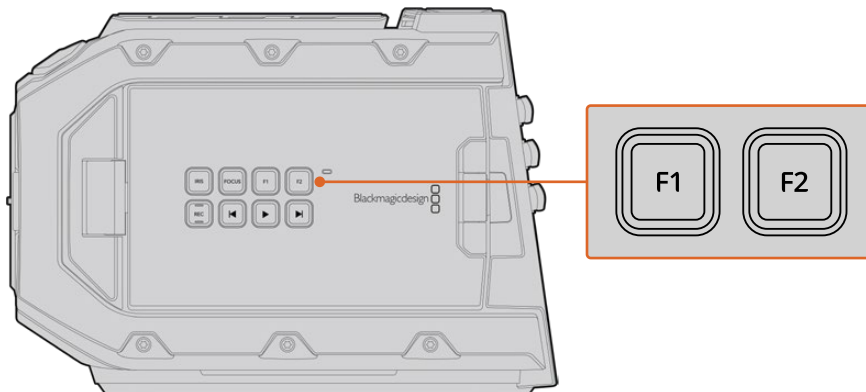

Your URSA Mini's F1 and F2 buttons are located on the outside of the LCD touchscreens

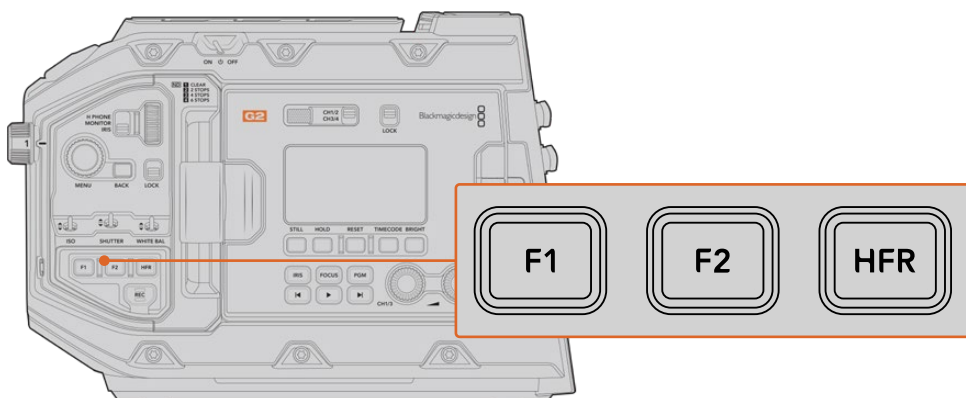

On URSA Mini Pro 12K, URSA Mini Pro 4.6K G2, URSA Mini Pro 4.6K and URSA Mini 4.6K, you can customize the functions of the 'F1', 'F2' and 'HFR' buttons or disable them.

**TIP** If your URSA Mini Pro G1 has a B4 lens with a lens connector, you can configure the 'vtr' and 'ret' buttons as function buttons and assign preset or toggle functions in addition to the 'F1', 'F2' and 'HFR' buttons.

To set these buttons, select a function button and then its behavior, a setting, and a parameter for that setting.

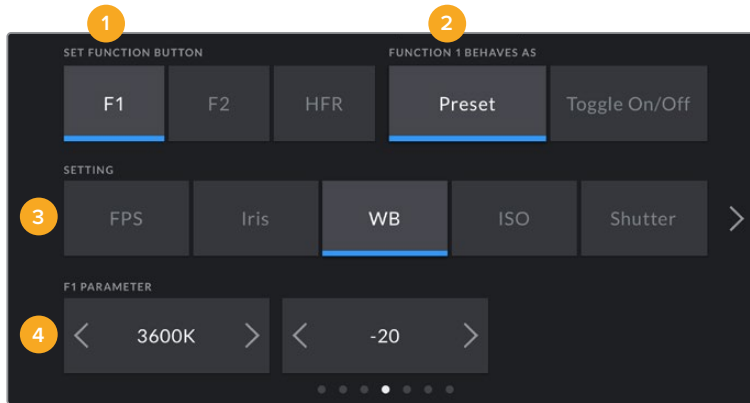

1 Button 2 Behavior 3 Setting 4 Parameter

### Function Button Behaves as Preset or Toggle

Once you have selected the function button you want to map, you can select a behavior. On URSA Mini Pro 12K, URSA Mini Pro 4.6K G2, URSA Mini Pro 4.6K and URSA Mini 4.6K models, you can also map the HFR button to another behaviour.

The available options are:

#### Preset

When set to this behavior, pressing a function button will recall a combination of a setting and a parameter.

To set a preset, select the setting you want to use from the 'setting' menu, and adjust that setting by tapping the arrow icons on either side of the 'parameter' menu.

For example, to set the F1 button to recall a preset aperture of f8, select the 'preset' behavior, tap the 'iris' setting, and tap the arrows on either side of the 'parameter' menu until you get to f8.' Tapping the preset again returns your camera to the previous setting.

#### Up/Down

When set to this behavior, pressing a function button will move a particular setting up or down.

For example, you may want to set F1 to increase your lens aperture and F2 to decrease it. To do this, select the 'F1' function button, set the behavior to 'up/down', and the parameter to 'up.' Do the same for the 'F2' function button, but set the option to 'down.'

#### Toggle On/Off

When set to this behavior, pressing a function button will toggle a particular setting on or off. The 'setting' menu is disabled in this mode. Instead, tap the left or right arrows in the parameter menu to scroll through the available options. These are 'off speed recording,' 'color bars,' 'push to talk,' 'clean feed,' 'display LUT,' 'frame guides,' 'focus assist,' 'false color,' and 'zebra'. A 'none' option is available on URSA Mini Pro models.

URSA Mini Pro 12K includes a 'focus zoom' option. For information on how to use 'focus zoom' when it is enabled on the LCD, see the 'focus zoom' section. When 'focus zoom' is enabled for your SDI outputs, you can move its region of zoom around using the 'menu' wheel and adjust the magnification level using the 'iris' wheel.

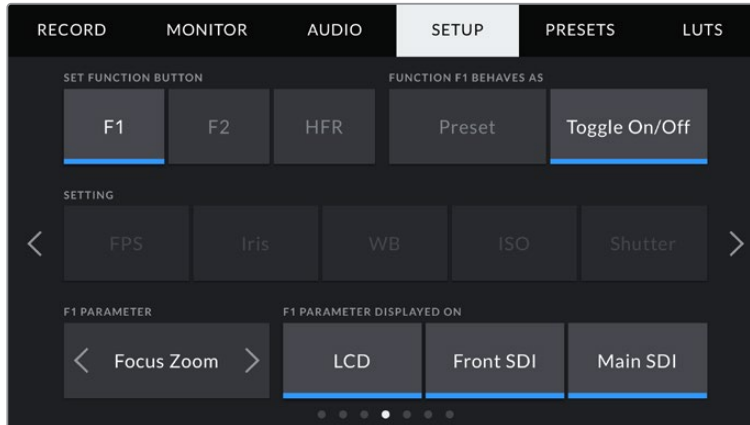

Focus zoom can be applied to any of the monitoring outputs selectively. For finding critical focus, applying it to all three outputs at will give the sharpest results.

Using the 'Toggle On/Off' behavior also lets you select the output this setting applies to. Simply tap any combination of 'LCD,' 'front SDI' and 'main SDI' to select. If the output for an option is not available, such as 'color bars' which always applies to all outputs, the 'LCD,' 'front SDI,' and 'main SDI' settings are disabled. On URSA Mini Pro models you can disable the function and HFR buttons by selecting 'none'.

**NOTE** When 'focus zoom' is set and applied to all 'LCD,' 'front SDI' and 'main SDI' outputs, any 3D LUT or focus assist settings applied to the 'front SDI' will apply to all three outputs when zoomed. Frame guides, grids and safe area guides will not be displayed when zoomed.

You can also configure URSA Mini Pro 4.6K G1 to use the 'ret' and 'vtr' buttons on a B4 lens as function buttons. For example, if ISO recording is happening with a HyperDeck, a popular option is to set 'vtr' to act as a 'push to talk' button.

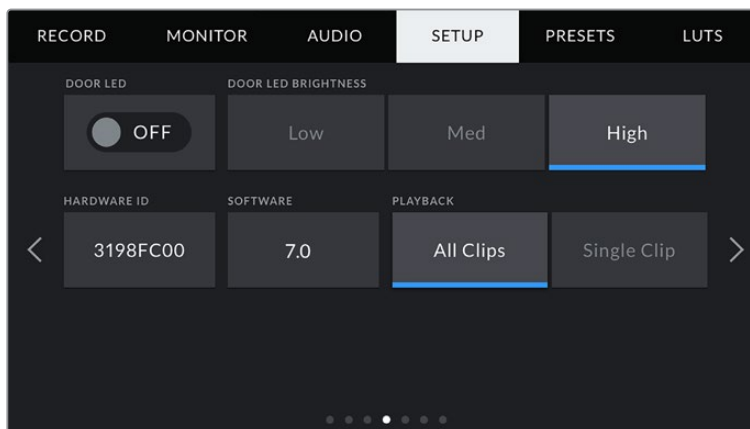

### Status LED

URSA Mini Pro cameras have a small status LED near the 'rec' button on the forward control panel to provide tally and status information. Use the 'status LED' setting to

switch the status LED on or off. On URSA Mini the status LED is located on the outside of the LCD touchscreen next to the 'F2' button and referred to as the 'door LED' on the 'setup' tab.

The LED will provide the following status indicators:

<b>White</b>	The camera is powered on and in standby mode.
<b>Red</b>	The camera is recording. Slow flashing indicates that your card space is low, while rapid flashing indicates dropped frames.
<b>Green</b>	The camera is in playback mode. The LED alternates slowly between green and off while a clip is playing. When inserted media is recognized, the status LED blinks green and white three times.
<b>Orange</b>	If your camera's battery is low, the LED will flash orange and your other current status color. For example, if currently recording, the LED indicator will slowly alternate between orange and red. If your camera is in standby mode, the LED will alternate between white and orange. The threshold for 'low' battery is 20 percent for batteries that support percentage accurate charge information, or 12.5 volts for batteries that don't.

### Status LED Brightness

To set the brightness of the status LED, 'low,' 'medium,' or 'high.'

### Hardware ID

The 'Hardware ID' indicator displays an 8 character identifier for your URSA Mini. This is unique to each camera. A longer, 32 character version of this ID is also included in the metadata for Blackmagic RAW and ProRes video. This can be useful for identifying which footage came from a particular camera if filenames are changed as the camera hardware ID remains constant.

### Software

Displays the current software version installed on your URSA Mini. See the 'Blackmagic Camera Setup Utility' section for more information on updating software.

### Playback

This setting allows you to select whether to play back a 'Single Clip' or 'All Clips' during playback. 'All Clips' will play back through all matching media sequentially, and 'Single Clip' will play one clip at a time. This also applies for the loop function. Selecting loop on 'All Clips' will play through all of the clips on the CFast 2.0 or SD card and then loop. Selecting 'Single Clip' will loop one clip at a time.

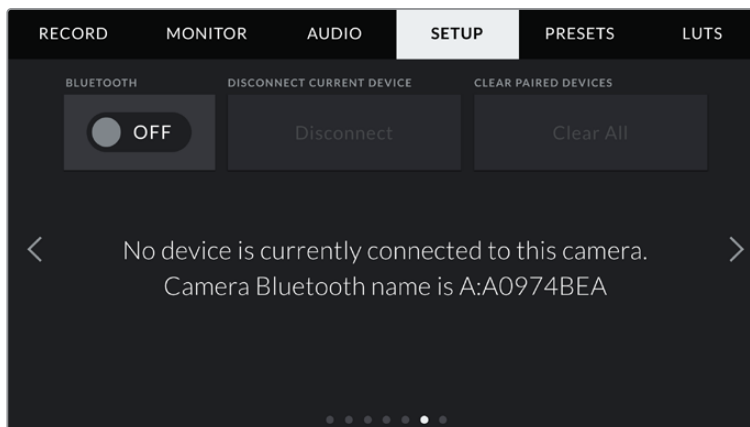

The camera Bluetooth name will be the letter of your camera as selected in the slate, followed by the 8 character hardware ID for your URSA Mini

## Bluetooth®

On URSA Mini Pro, Bluetooth control allows you to control your camera wirelessly from portable devices. Using the 'Blackmagic Camera Control App' you can power the camera on or off, change settings, adjust metadata and trigger record remotely from an iPad. You can enable or disable Bluetooth by tapping the 'Bluetooth' switch icon in the 'setup' menu. When Bluetooth is enabled, the camera can be detected by Bluetooth devices up to 30 feet away.

Because URSA Mini Pro uses the same set of commands for Bluetooth control as it does for 'Blackmagic SDI Camera Control Protocol', you can write your own applications to control almost every setting in the camera remotely, from monitoring to audio settings, the camera's inbuilt DaVinci Resolve color corrector or lens control.

For more information see the 'Blackmagic SDI Camera Control Protocol' section in this manual.

### To pair your camera with an iPad for the first time:

- 1 Enable Bluetooth by tapping the 'Bluetooth' switch icon in the 'setup' menu on your URSA Mini Pro.
- 2 Open the 'Blackmagic Camera Control App' and select the URSA Mini Pro you would like to pair with. Available cameras will be listed by their camera letter, followed by their unique hardware ID. For example A:A0974BEA.

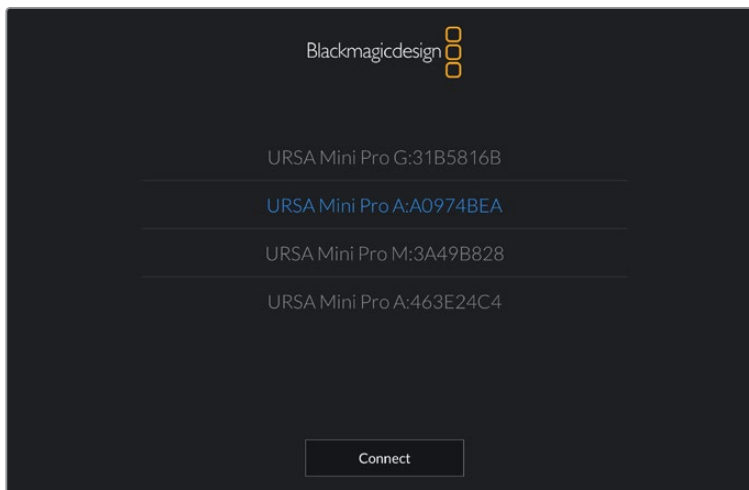

Select the URSA Mini Pro you would like to pair with

**NOTE** When you install the Blackmagic Camera Control App and run it for the first time, you will be asked if you want to 'allow location access.' If you select 'while using the app,' GPS readings from your iPad will be included in the metadata of the files you shoot, allowing you to geotag footage. This information can be viewed in Blackmagic DaVinci Resolve versions 14 or higher.

If you do not want to using this information, select 'never.'

To change settings, go to settings, privacy, location services, camera control on your iPad.



- 3 When you try to connect for the first time the Blackmagic Camera Control App will request a six digit code to pair with the camera. This code will be displayed on the camera's LCD screen. Type this code into the iPad.

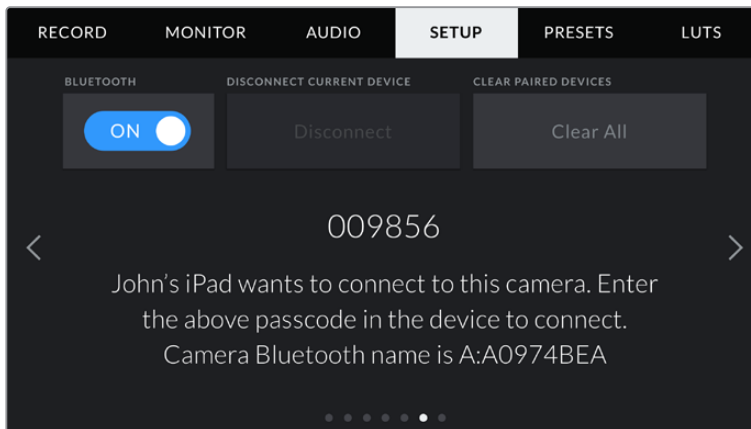
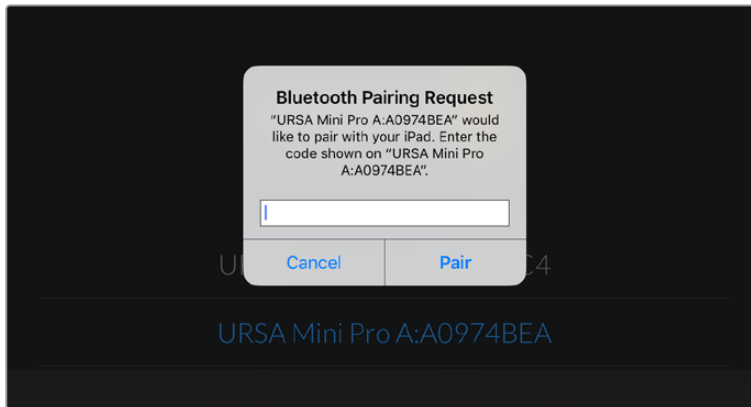

- 4 The information on the screen will confirm that your URSA Mini Pro is now paired with your iPad.

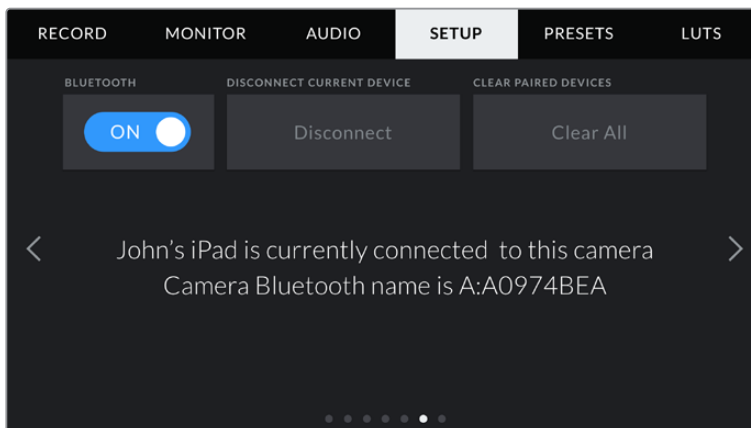

- 5 If there is a problem pairing the camera to your iPad you will see the following error message.

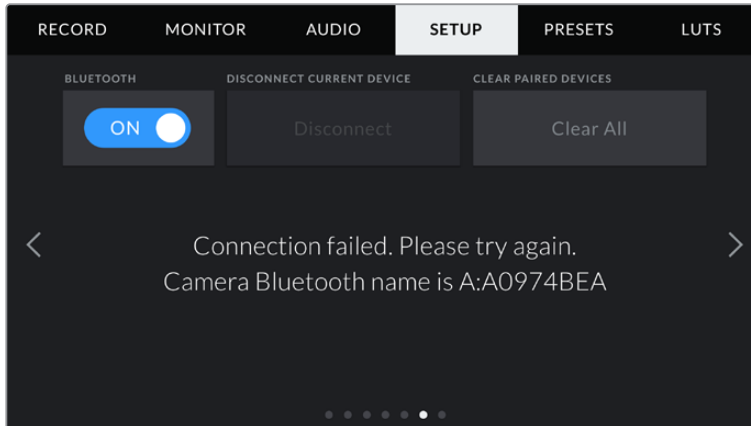

**NOTE** If you are not using Bluetooth to control your URSA Mini Pro, it is a good idea to turn Bluetooth off for the purpose of security.

#### **Disconnect Current Device**

Use this setting to disconnect your URSA Mini Pro from the iPad it is currently paired with.

#### **Clear Paired Devices**

Use this setting to clear the list of devices that your URSA Mini Pro has been paired with.

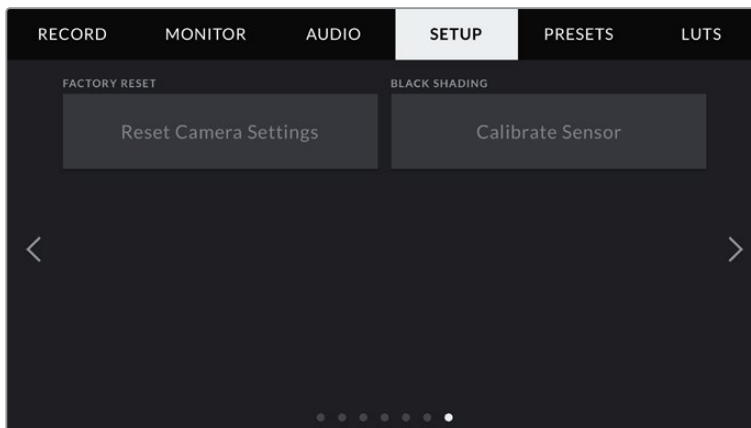

#### **Factory Reset**

To reset the camera to its default factory settings, tap the 'reset' button. You will be asked to confirm this action as it will erase any LUTs and presets currently stored on the camera. Tap 'reset' on the confirmation page to reset your camera settings.

It's important to note that a factory reset erases any presets and custom LUTs, and resets all settings. It is a good practice to export them to a memory card as a backup before performing a factory reset. After a factory reset, you can restore your presets and LUTs quickly by importing them from the memory card. You are also advised to perform a black shading calibration.

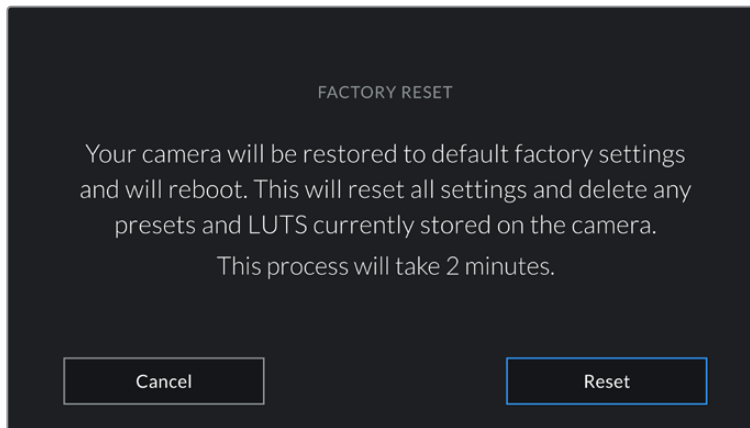

When selecting 'factory reset' you will be prompted to confirm your action

### Black Shading

On URSA Mini cameras using the 4.6K sensor, the black shading feature optimizes image quality by balancing the black levels on the sensor. It is best to carry out this process after your camera has warmed up and has been running for a few minutes. To carry out a black shading calibration you will need to place the dust cap on the camera, or place the lens cap on the lens and then press the 'calibrate' button. You will be asked to confirm this action, as you require the correct setup for this to function correctly. Calibration will take a few seconds, and you will be notified when the process is completed. Your camera will remember the last date and time that black shading was completed. This will optimize image quality in the shadows.

URSA Mini Pro 4.6K G2 has an additional calibration feature as part of the black shading process, which allows you to recalibrate pixels for improved black levels. This will take approximately one minute to complete.

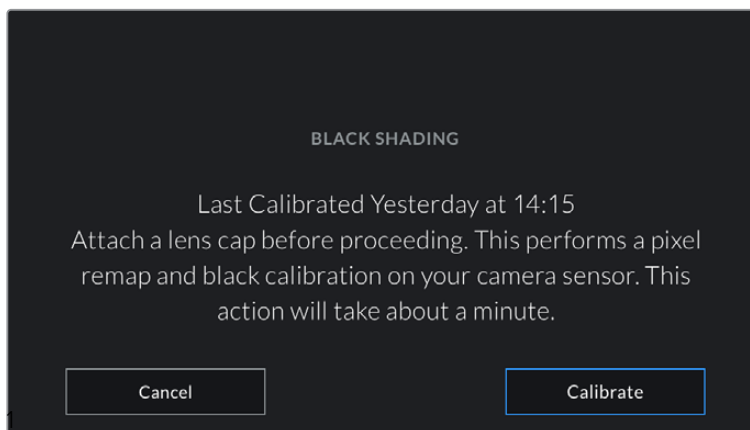

Black shading calibration recommended

### Motion Sensor Calibration

To calibrate the horizon meter on URSA Mini Pro 12K, place your camera on a surface you know is level and tap the 'calibrate motion sensor' button. It is essential that you keep the camera stable during calibration. The process takes approximately five seconds to complete.

## Controlling Your Camera with the Blackmagic Camera Control App

Once you have successfully paired your URSA Mini Pro to your iPad, you can power the camera on or off, change settings, adjust metadata and trigger record remotely using the iPad app.

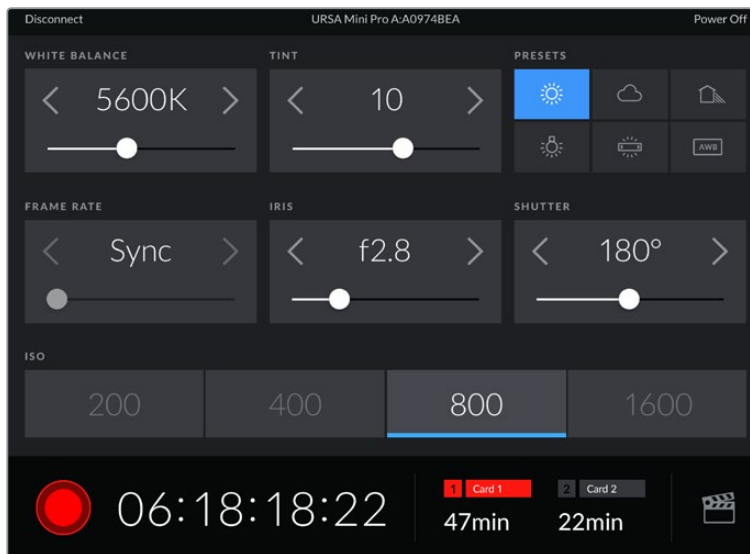

Once paired, the Blackmagic Camera Control app will display this screen, allowing you to adjust your settings and start recording

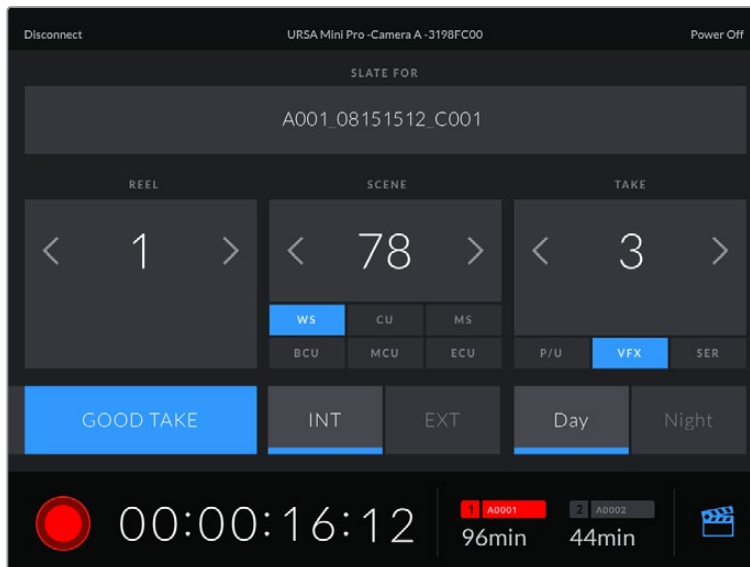

Tap the slate icon in the lower right corner to access and update the slate

URSA Mini Pro uses Bluetooth LE to communicate with devices for wireless control. As this is the same type of protocol used in portable devices, it only uses a minimal amount of battery power.

You can power off your URSA Mini Pro by tapping 'power off' in the top right corner.

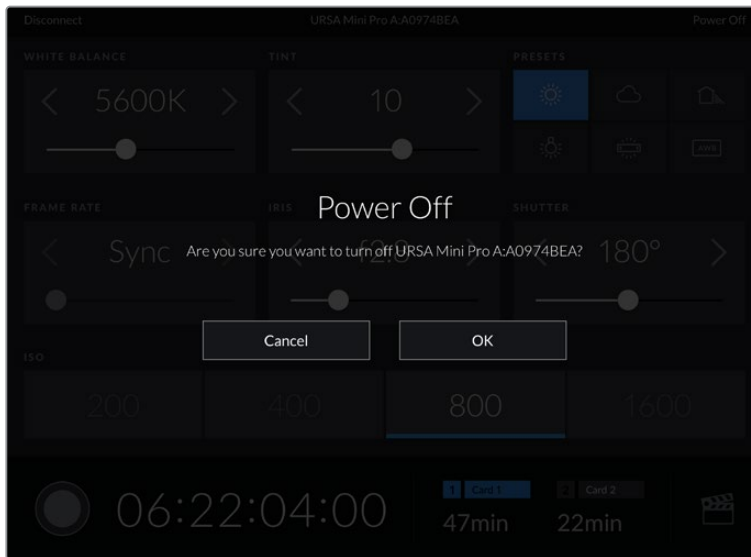

You will be prompted to confirm your selection before your camera is powered off

When Bluetooth is enabled and your URSA Mini Pro is powered off, the name of your camera will still show up on the list of available devices in the Blackmagic Camera Control App. Since you have already paired with your camera, you can now switch it on remotely by selecting your camera name and tapping 'Connect'. Your camera will not show up in this list if Bluetooth is disabled.

## Presets

The 'presets' tab lets you save and recall a complete collection of settings for your URSA Mini. This is very useful when one camera is used for multiple projects. For example, you may use your URSA Mini for a variety of different shoots, from documentaries to music videos, with very different settings between types of projects. Your URSA Mini's 'presets' function lets you save the setup for a particular project or type of shoot and come back to it quickly and easily when required. It's worth noting that some settings saved to a preset on URSA Mini may not be compatible with other Blackmagic cameras or earlier software versions for URSA Mini. To ensure your camera has the latest software installed please refer to the Blackmagic Design support center at [www.blackmagicdesign.com/support](http://www.blackmagicdesign.com/support).

You can also import and export presets, which is very useful for setting up a multi camera shoot. Simply set up one URSA Mini to suit your project, then export that preset for all the other URSA Minis on set.

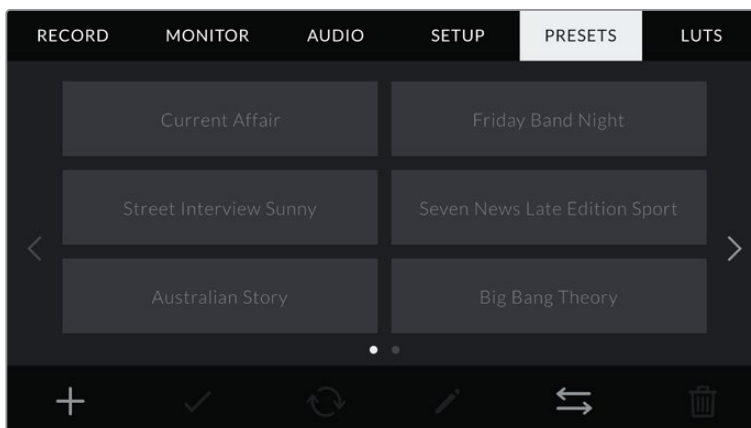

Your URSA Mini's Presets tab

**NOTE** Your URSA Mini can save up to twelve presets to its internal memory.

### Preset buttons

The button icons along the bottom of your URSA Mini's 'preset' menu correspond with the following functions.

				
<b>Add</b>	<b>Load</b>	<b>Update</b>	<b>Manage</b>	<b>Delete</b>

### Saving and loading presets

To create a new preset, tap the 'add' icon. This will bring up a touch keyboard on your LCD touchscreen where you can name your preset. Once you've typed in the name, tap 'update' to save all of your URSA Mini's current settings to that preset.

If your URSA Mini already has a preset loaded with the same name, you will be prompted to overwrite the existing preset or keep both.

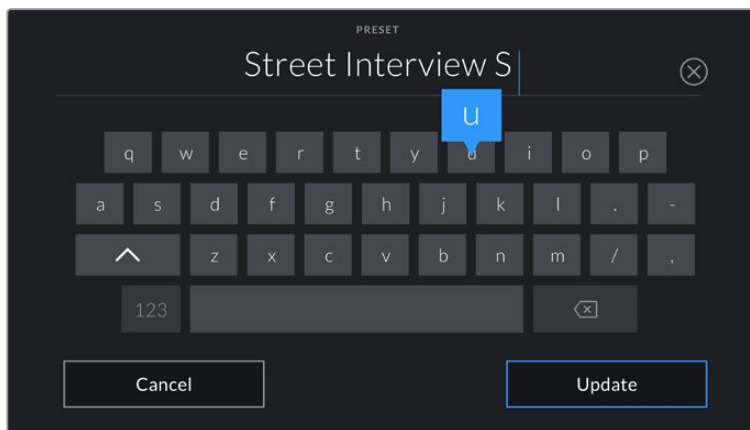

Enter a name for your preset by tapping the 'add' icon in the preset tab and using the touch keyboard

Once you have a preset saved, tap its name in the preset menu to select it. To load it tap the 'load' icon.

You can update a preset by tapping the 'update' icon. This will bring up a prompt asking you if you want to update the preset with your URSA Mini's current setting. Tap 'update' to confirm.

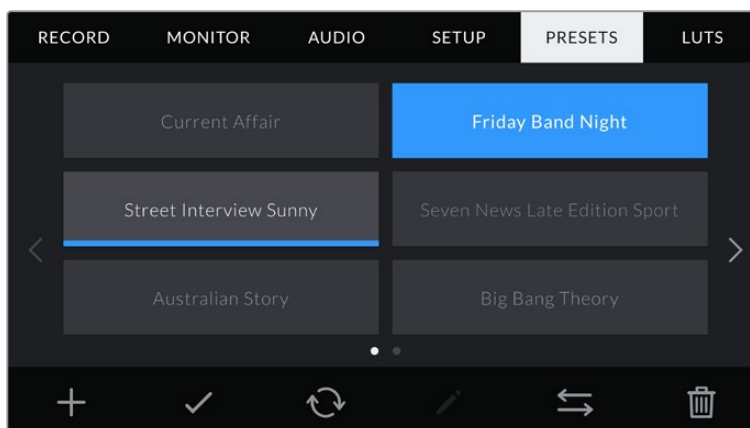

Select a preset and tap the 'load' icon to load it. Selected presets will appear solid blue, while currently loaded presets have a blue line along the bottom of their icon

### Importing presets

To import presets, tap the 'preset manager' icon at the bottom of the preset menu. On URSA Mini Pro select either SD or CFast with the storage media selection switch, depending on where your presets are saved. If you are using URSA Mini Recorder, you can also import presets from an SSD.

Tap 'import preset' and confirm your selection with the 'import' icon. This will bring up the import screen. Choose 'card 1' or 'card 2' at the top left of this screen to display any available presets on those cards.

Your URSA Mini will search the root directory and 'presets' folder on the selected CFast or SD card. It's worth noting that presets saved elsewhere on your CFast or SD cards will not be visible.

Tap a preset to select it, and tap 'import' to confirm. At the top right of this screen, you'll see the number of remaining empty preset slots available on your camera.

**NOTE** If your URSA Mini's preset slots are full, the import menu will not be available. You will need to delete an existing preset to make room.

### Exporting presets

To export a preset to a CFast or SD card, select the preset you want to export by tapping it, and tap the 'manage' icon. You will be prompted with two options, 'import preset' or 'export selected preset.'

Use the storage media selection switch on URSA Mini Pro to select either SD or CFast, depending on the location you would like to export the preset to. If you are using URSA Mini Recorder, you can also export presets to an SSD. Tapping 'export selected preset' will prompt you to choose which card you would like to export to. Choosing a card will export the selected preset to a 'presets' folder on that card.

If the CFast or SD card you've chosen already has a preset saved to it with the same name as the one you're exporting, you will be prompted to overwrite the preset on the card, or keep both presets.

### Deleting presets

Your URSA Mini has space for twelve presets. To delete a preset, select it and tap the 'delete' icon. You will be prompted to confirm your choice. Tap 'delete' to confirm.

## LUTS

The 'LUTS' menu lets you import, export and apply 3D LUTs to your camera's outputs.

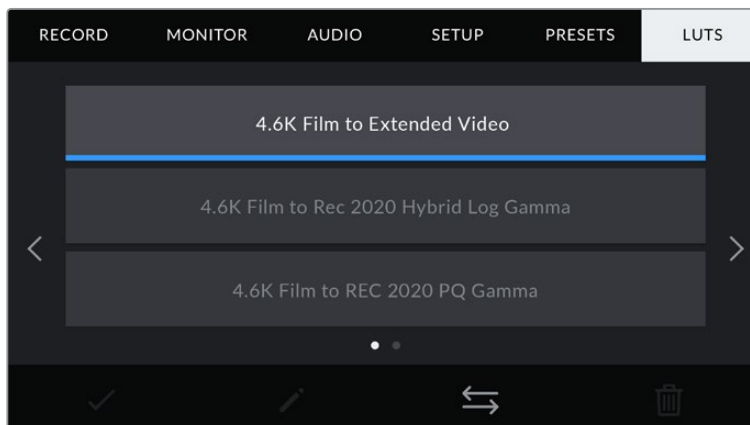

Your URSA Mini's 'LUTS' tab

## Introducing 3D LUTs

Your URSA Mini can apply 3D LUTs to images on its LCD touchscreen, front SDI and main SDI. LUTs work by telling your URSA Mini what color and luminance output to show for a particular color and luminance input. For example, a LUT may tell your URSA Mini to display a vibrant, saturated blue when it receives a relatively dull blue input. This can be useful when shooting Blackmagic RAW footage, or using 'film' dynamic range, both of which have an intentionally undersaturated, 'flat' appearance. By applying a LUT, you can get an idea of what your footage will look like after it has been graded.

It is easy to create 3D LUTs using DaVinci Resolve or other color correction software, and LUTs are available online from a variety of sources. Your URSA Mini can store up to six 17 point or 33 point 3D LUTs, of up to 1.5 megabytes each. Once loaded, you can choose to display a given LUT on your camera's LCD touchscreen, front SDI, main SDI or any combination of these outputs.

Your URSA Mini supports 33 point 3D LUTs in .cube format created in DaVinci Resolve and 17 point 3D LUTs converted to Resolve .cube format via LUT conversion programs. Your camera processes 3D LUTs using high quality tetrahedral interpolation.

**TIP** For more information on displaying LUTs, see the 'monitor settings' section in this manual.

**NOTE** LUTs are used as a preview tool only. Your URSA Mini does not apply, or 'bake in,' LUTs to recorded footage, however information on the LUT applied during a shot is saved as metadata with your recordings. The 'LUT used' field in DaVinci Resolve can be used to verify the name of the LUT that was used as a monitoring LUT on set. Blackmagic RAW lets you non-destructively embed a LUT you use during filming into the RAW file for use in post production. This gives you the option in DaVinci Resolve to use the LUT or apply a different look. For more information see the 'Embedded 3D LUTs' section.

## Built-in LUTs

Your URSA Mini provides a number of built-in LUTs, that allow you to preview different looks when shooting in 'film' dynamic range in ProRes or Blackmagic RAW.

<b>Film to Extended Video</b>	Displays a wider dynamic range than the '4.6K Film to Video' LUT, and applies a mild contrast change with a smooth roll off in the highlights.
<b>Film to Video</b>	Similar to the REC 709 color standard for high definition video, and has a high level of contrast and saturation. You may find this setting useful when using URSA Mini alongside other broadcast cameras using the REC 709 color space.
<b>Film to Rec 2020 Hybrid Log Gamma</b>	Displays a hybrid between REC 709 and a log image.
<b>Film to Rec 2020 PQ Gamma</b>	Displays a gamma curve that is based on what we can perceive with our eyes, for efficient encoding of HDR images.



## LUTs buttons

The button icons along the bottom of your URSA Mini's 'LUTS' screen correspond to the following functions:



## Importing LUTs

To import a 3D LUT, tap the 'manage' icon at the bottom of the LUT menu, and tap 'import LUT' to confirm.

This will bring up the import screen. On URSA Mini Pro select either SD or CFast with the storage media selection switch, depending on where your LUTs are saved. You can also import LUTs stored on an SSD if you are using URSA Mini Recorder. Choose 'card 1' or 'card 2' at the top left of this screen to display any available 3D LUTs on those cards.

Your URSA Mini will search the root directory and '3DLUTS' folder on your selected CFast or SD card. Any LUTs you have saved elsewhere will not be visible.

Tap a LUT to select it and tap 'import' to confirm your selection. The LUT will be saved to your URSA Mini.

**NOTE** If your URSA Mini's 3D LUT slots are full, you will not be able to import until you delete some existing LUTs to make space.

If the LUT you want to import has the same name as a LUT already saved to your camera, you will be prompted to overwrite the existing LUT or keep both. At the top right of this screen, you'll see the number of remaining empty LUT slots available on your camera. You will only be able to import as many LUTs as you have free slots on your camera.

**NOTE** If you are having trouble importing a LUT to your URSA Mini, it may be the wrong size. You can use a LUT editor like Lattice to check its size, or open it in any text editor on your computer. Next to the tag 'LUT\_3D\_SIZE' will be a number indicating the LUT's size. If this value is not 17 or 33, you can use Lattice to resize your 3D LUT to 17 points.

## Applying a LUT

Once you have a LUT saved onto your camera, tap it in the LUT menu to select it, and tap the 'load' icon. This will enable that LUT to all outputs on your camera. However, you will still have to turn 'display LUT' on in the monitor menu for each output to apply it. The LUT icon will be visible on the LCD, front SDI or main SDI when 'status text' is switched on and you have a LUT applied to that output. See the 'monitor settings' section in this manual for more information.

### **Exporting LUTs**

To export a LUT to a CFast or SD card, select the LUT you want to export and tap the icon. You will be prompted with two options, 'import LUT' and 'export selected LUT.' Use the storage media selection switch on URSA Mini Pro to select either SD or CFast, depending on the location you would like to export the LUT to. If you are using URSA Mini Recorder, you can also export LUTs to an SSD.

Tapping 'export selected LUT' will prompt you to choose which card you want to export to. Choosing a card will commence exporting, unless you are exporting a LUT that already exists on that card. If a duplicate LUT is found, you will be asked if you want to overwrite the LUT on your card, or if you would like to keep both.

### **Deleting LUTs**

Your URSA Mini has space for six 17 point or 33 point 3D LUTs. To delete LUTs you are no longer using, or make room for more, select the LUTs you want to delete and tap the icon. You will be prompted to confirm your choice. Tap 'delete' to confirm.

### **Embedded 3D LUTs**

When a 3D LUT is used whilst shooting Blackmagic RAW on Blackmagic URSA Mini Pro models, the selected LUT will be embedded into the Blackmagic RAW file that you are recording. The 3D LUT is actually saved with your recorded files in the header of the .braw file, and can easily be applied to footage in post production without needing to handle a separate file.

So when Blackmagic RAW files are delivered to an editor or colorist, they will be able to easily access the LUT that was used whilst filming, which greatly reduces the possibility that the wrong 3D LUT could be applied to a clip. They can then choose whether to apply the 3D LUT whilst editing or color grading the footage, and can disable the 3D LUT at any time.

When the 'apply LUT in file' switch is set to 'on' in URSA Mini Pro's record menu, the recorded clip will open in Blackmagic RAW Player and DaVinci Resolve with the chosen 3D LUT already applied to it. The 3D LUT can then be easily toggled 'on' or 'off' but will always travel with the Blackmagic RAW file as it is written into the clip itself.

DaVinci Resolve also has an 'Apply LUT' switch in the RAW settings palette for enabling or disabling the 3D LUT in the Blackmagic RAW file. The 'Apply LUT' setting in DaVinci Resolve is the same setting as in the camera. This means that when shooting you can direct the colorist to use the LUT by setting it in the camera, but they can switch it off easily in DaVinci Resolve by setting 'Apply LUT' to 'off'.

# Entering Metadata

Metadata is information saved inside your clip, such as take numbers, camera settings and other identifying details. This is extremely useful when sorting and processing footage in post production. For example, take and shot and scene numbers are essential organizational tools, while lens information can be used to automatically remove distortion or better match VFX assets to plates.

Your Blackmagic URSA Mini automatically saves some metadata to each clip, such as camera settings, timecode, date and time. You can use your camera's slate to add many additional details.

## The Slate

Swiping left or right on your URSA Mini's touchscreen will bring up the slate.

The slate is divided into two tabs, 'clips' and 'project.' The 'clip' tab contains information that may vary clip by clip, while 'project' is where you enter details common between clips, such as the project name, director, and camera and operator ID.

**TIP** Metadata entered into the slate is viewable on your URSA Mini's front or main SDI outputs when 'display status text for' is set to 'director' on the 'monitor' tab. See the 'monitor settings' section in this manual for more information.

### 'Clip' metadata

Changes made to clip metadata work slightly differently in standby mode, when your URSA Mini is ready to record, and playback mode, when you're reviewing footage you've already shot. In 'standby,' clip metadata will be saved to the next clip recorded, except for 'good take last clip' which refers to the most recently recorded clip.

In playback mode clip metadata is always recorded to the current clip being viewed.

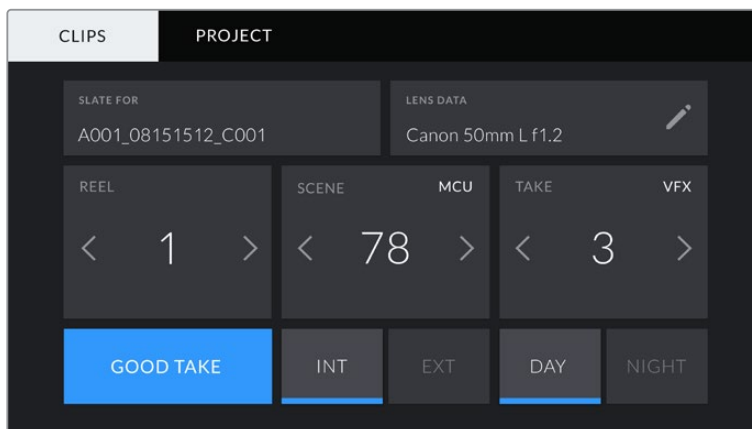

Your URSA Mini's slate is divided into 'clip' and 'project' tabs

### Slate for

This setting shows the clip which the metadata currently displayed in the 'clip' applies to. In standby mode, this refers to the next clip that will be recorded.

## Lens Data

These settings display information about the current lens fitted to your camera. Many electronic lenses automatically supply information such as the lens model, aperture and focal length. If you are using a lens that does not provide this information, or you want to enter additional data, you can tap the pencil icon in this setting to enter the information manually. This will bring up the 'lens data' menu, which contains the following information:

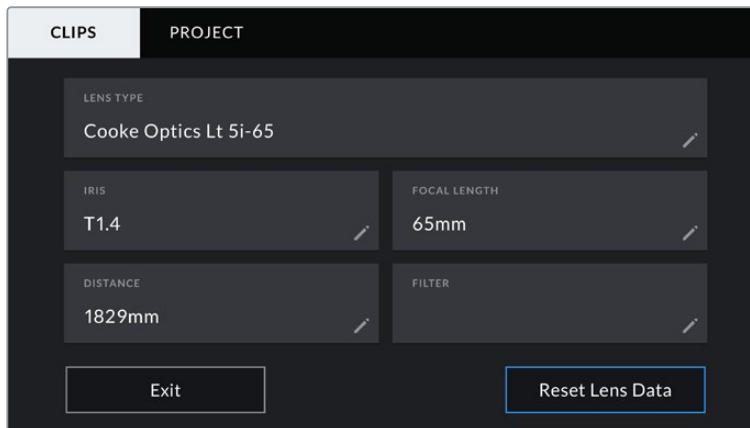

The 'lens data' menu showing information automatically populated from a lens with Cooke/i Technology

## Lens Type

Shows the lens model. If your lens type is not automatically shown here, you can tap this setting to enter the data manually. Your camera has an internal database stored for many commonly used lenses, so if you need to enter data manually, your camera will suggest names automatically as you type. This makes entering data much faster.

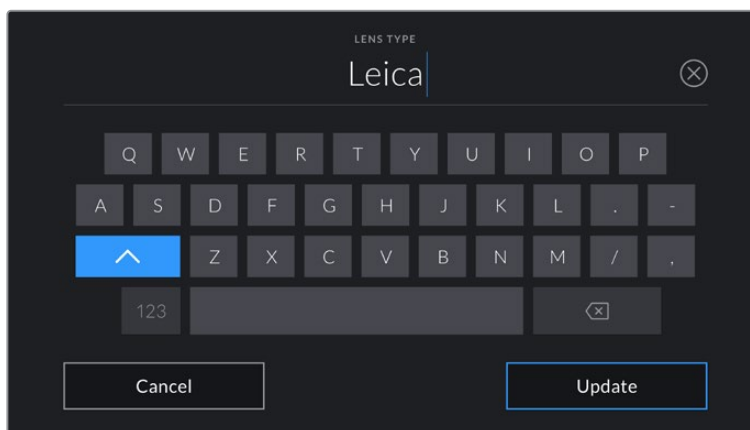

Use the touch keyboard to enter lens data if it is not provided automatically

## Iris

Shows the iris aperture setting at the start of your clip. This information can be displayed in f- or T-stops depending on the lens used, if supplied automatically. Tap this setting to enter data manually.

## Focal length

Shows the focal length setting of the lens at the start of the recorded clip. When automatically supplied, this is shown in millimeters. Tap this setting to enter data manually.

### Distance

Shows the focus distance settings of the lens for the recorded clip. Some lenses can provide this data automatically and it will be provided in millimeters. You can also enter this data manually.

### Filter

Shows the current lens filters used. Tap this setting to enter data manually. You can make multiple entries separated by commas.

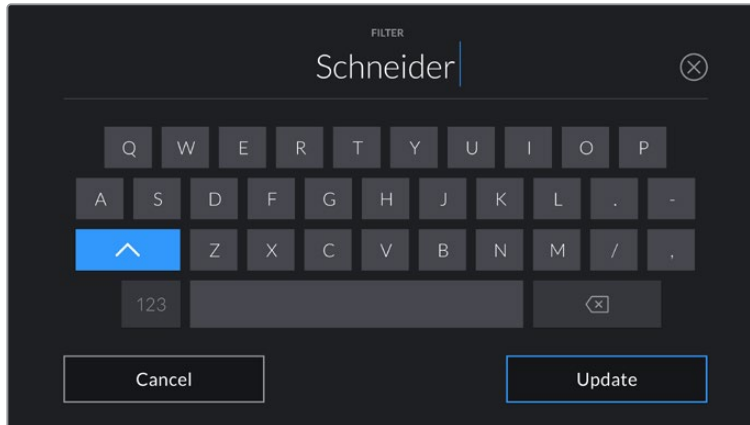

Filter information needs to be entered manually

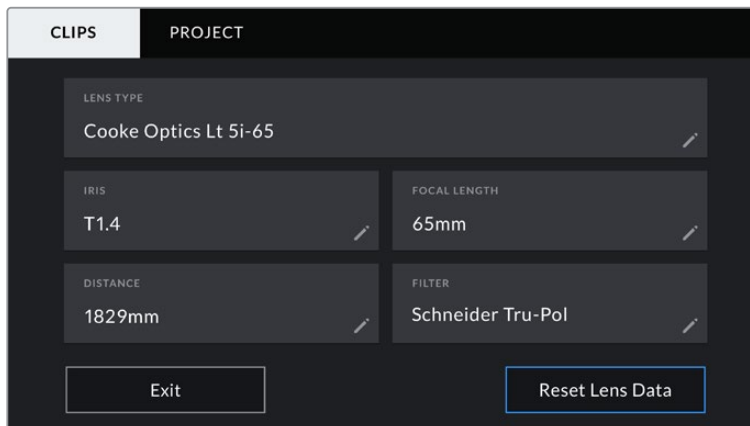

The 'lens data' menu showing information automatically populated from a lens with Cooke /i Technology, and filter information that has been manually entered

**NOTE** You can clear lens data at any time by tapping the 'reset lens data' icon in the 'lens data' menu. You will be prompted to confirm your choice. If you confirm, all lens data will be cleared and repopulated with any lens data automatically provided by the currently fitted lens. If you have manually entered any information into these fields, you will need to reset the lens data the next time you mount a lens, otherwise the manually entered value will remain.

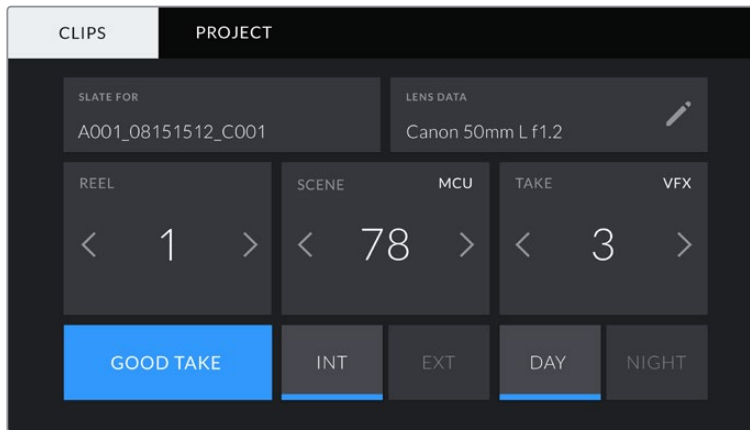

Your URSA Mini's slate is divided into 'clip' and 'project' tabs

### Reel

The 'reel' indicator shows the current reel.

Your URSA Mini automatically increments reel numbers, so there is usually no need to enter this manually. When you are moving to a new project and want to start from reel '1' again go into the project tab of the slate and tap 'reset project data'.

### Scene

The 'scene' indicator shows the current scene number, and can also show the current shot number and type.

The number on this indicator always refers to the current scene. You can move this up and down using the left and right arrows on either side of the scene number, or tapping the scene number to enter the scene number editor.

The range of possible scene numbers is 1 to 9999.

By adding a letter to the scene number in the scene number editor, you can also indicate the current shot. For example 23A would indicate scene twenty three, shot one. If you have a shot letter added to your scene, your URSA Mini will suggest letter increments whenever you enter the scene number editor. For example, if your current scene number is 7B, your URSA Mini will offer '7C' as an increment suggestion.

The scene number indicator can also show information about the current shot type in the top right corner. You can select these in the scene number editor at the right hand side of the shot keyboard.

The shot types available are:

<b>WS</b>	wide shot
<b>MS</b>	medium shot
<b>MCU</b>	medium close up
<b>CU</b>	close up
<b>BCU</b>	big close up
<b>ECU</b>	extreme close up

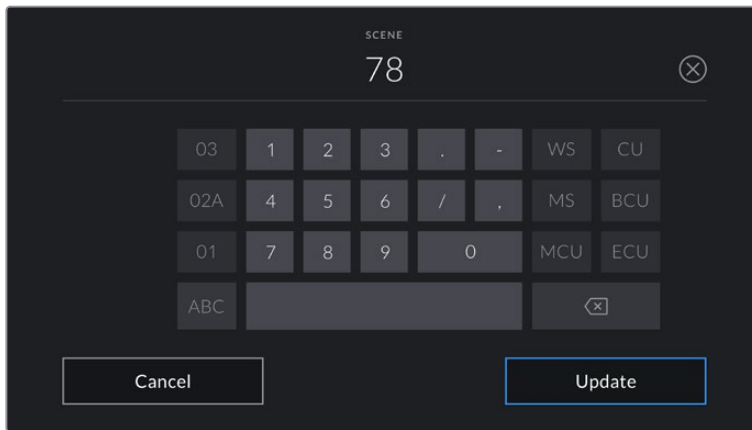

When entering 'scene' metadata, your URSA Mini will prompt you with increment suggestions to the left of the touch keyboard, and shot types to the right

### Take

The 'take' indicator shows the take number for the current shot. You can increment this up or down by tapping the left or right arrows on either side of the take number, or tapping the indicator to enter the take number editor.

**TIP** When the shot number or scene letter are advanced, the take number will revert to '1.'

You can add take descriptions in the take number editor. These are offered to the right of the take number keyboard, and correspond to the following scenarios:

<b>PU</b>	'Pick up.' This refers to a reshoot of a previous take to add additional material after principal photography has wrapped.
<b>VFX</b>	'Visual effects.' This refers to a take or shot for visual effect use.
<b>SER</b>	'Series.' This refers to a situation in which multiple takes are shot while the camera is kept running.

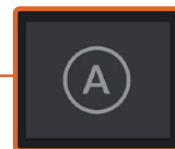
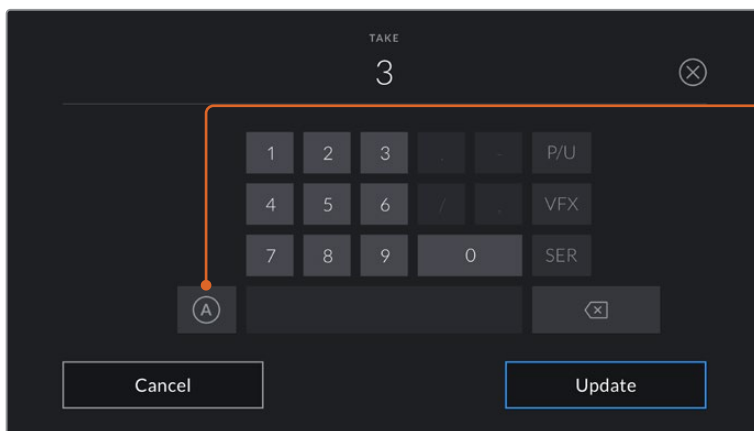

Tap 'A' to automatically increment the take number for each clip while in 'standby' mode.

A small 'A' appears next to the take number on the slate when enabled.

When entering 'take' metadata, your URSA Mini will offer prompts for additional shot types to the right of the touch keyboard

### Good take

Tap the 'good take' indicator to flag good takes for easy recall in post production. This tag applies to either the last clip recorded, if your URSA Mini is in standby mode, or the clip currently being viewed in playback mode.

### Int / Ext

Tap 'int' or 'ext' to add a 'interior' or 'exterior' tag to the next clip in standby mode, or the current clip in playback mode.

### Day / Night

Tap the 'day' or 'night' icons to add a 'day' or 'night' tag to the next clip in standby mode, or the current clip in playback mode.

## 'Project' Metadata

Project metadata behaves the same way whether you are in standby or playback mode. This metadata always refers to your project as a whole and is independent of clip numbers.

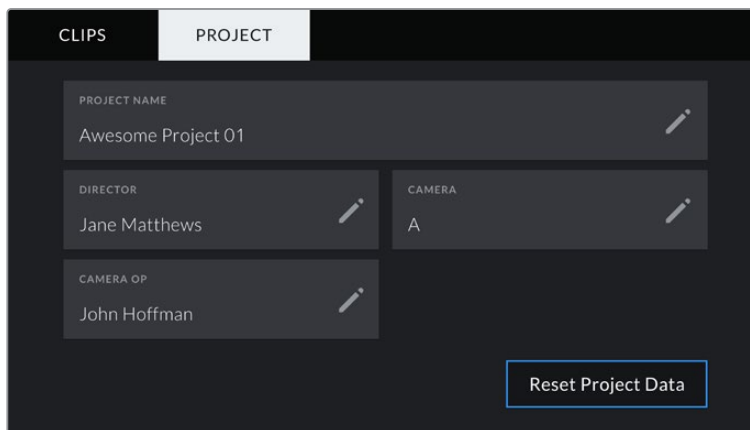

Your URSA Mini's 'project' slate tab

### Project name

Displays your current project name. Tap the pencil icon to change the project name.

### Director

Displays the director's name for the current project. Tap the pencil icon to change the director name.

### Camera

Displays a single letter camera index. Tap the pencil icon to change the camera index.

**NOTE** Camera index is used in metadata and for file naming purposes and differs from your URSA Mini's ATEM Camera ID, which is used when controlling your URSA Mini with an ATEM switcher. For more information on ATEM Camera ID, see the 'Understanding Studio Camera Control' section in this manual.

### Camera Op

Displays the camera operator. Tap the pencil icon to change the camera operator name.



## Using Servo Zoom Lenses

Using servo zoom lenses with your URSA Mini camera is a powerful combination. Manual iris, zoom and focus rings on the lens barrel, plus a built in hand grip and zoom rocker makes shooting very efficient and gives you a range of dynamic techniques that are difficult, if not impossible, to achieve using other lens types. URSA Mini PL and URSA Mini Pro models currently support lens control for B4 and cine-servo PL zoom lenses via the 12 pin broadcast connector.

When using compatible lenses you can power the zoom rocker, start and stop recording using the record button, and control the iris. Most servo zoom lenses also have a 'Ret' button, which can be used, in the same way as the PGM button on the camera, to switch the feed on the LCD and HD monitoring output between camera view and program return view.

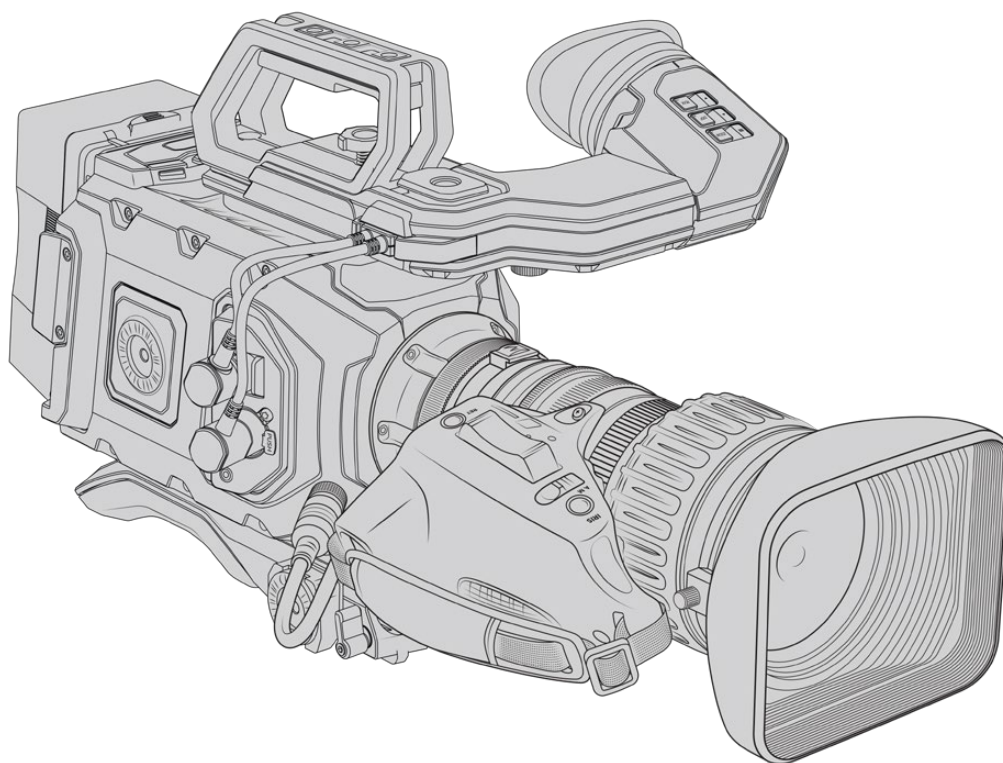

For electronic control of your lens aperture, make sure the iris switch on the top of the zoom rocker is set to 'A' or 'auto'. Electronic zoom control is also possible with Digital HD and 4K servo zoom lenses. To enable this you must make sure the switch under the zoom rocker labelled 'zoom' is set to 'S' for servo zoom.

As there are so many different variants of B4 lenses this guide should help you work out which models have the feature set you require.

### **B4 Lenses with iris and zoom control include:**

- Fujinon B4 lens models with HA, ZA, XA, UA and LA prefixes in their model name and RM in their suffix will have electronic iris and zoom control.
- Canon B4 lens models with HJ, KJ and CJ prefixes and IRSE or IRSD in their suffix will have electronic iris and zoom control.

Some B4 and PL lenses also have handgrips with electronic focus servo. To ensure this is functioning with URSA Mini PL or URSA Mini Pro, and able to be controlled electronically, set the switch under the zoom rocker labelled 'focus' to 'S' for servo.

**B4 Lenses with full servo control for focus, iris and zoom include:**

- Fujinon B4 lens models with HA, ZA and UA prefixes in their name and the letters RD or ZD in the suffix.
- Canon B4 lens models with HJ, KJ..ex and CJ prefixes in their name and the letters IASE or IASD in the suffix.

Lenses that also have motorized focus control can even utilize the ‘focus’ button on your URSA Mini to activate auto focus, and focus can be controlled remotely by an ATEM switcher via ATEM Software Control.

Once you have attached a B4 lens, set the resolution to 2K 16:9 or lower, and ‘window sensor’ to ‘on’ in the ‘record’ tab of the dashboard. It is important to use these settings to prevent vignetting of the image, as B4 lenses do not cover the super 35mm image circle.

**Super 35mm PL lenses with full servo control of focus, iris and zoom include:**

Brand	Series	Model	Range	Max. Aperture
Fujinon	Cabrio	ZK2.5x14-SAF	14-35mm	T2.9
Fujinon	Cabrio	ZK4.7x19-SAFB	19-90mm	T2.9
Fujinon	Cabrio	ZK3.5x85-SAF	85-300mm	T2.9-T4
Fujinon	Cabrio	XK6x20	20-120mm	T3.5
Fujinon	Cabrio	ZK12x25 with ESM-15A-SA	25-300mm	T3.5-3.85
Canon	Cine-servo	CN7x17KAS S	17-120mm	T2.9-3.9
Canon	Cine-servo	CN20x50	50-1000mm	T5-8.9

Focus and zoom controls can also be used to drive focus and zoom from the pan handles in a studio environment on all of the PL and B4 servo zoom lenses listed above.

**Hybrid compact-servo zoom lenses**

Recently a new category of lenses known as ‘compact-servo’ zoom lenses have been introduced. These have some of the functionality of B4 and PL servo zoom lenses but use an EF mount. The zoom rocker for these lenses are able to be powered through the lens mount from URSA Mini EF and URSA Mini Pro and information such as lens name, iris, focus and zoom position values are all able to be read and recorded by URSA Mini’s lens metadata system.

Electronic control of the focus, iris and zoom is available with these lenses on URSA Mini and URSA Mini Pro. When connected to a switcher, these can also be controlled remotely via ATEM Software Control. If you are operating in a live broadcast or studio environment, use of Canon digital focus and zoom control is possible, but additional custom cables are required from 3rd party manufacturers for full functionality.

**Lenses in this range include:**

- Canon CN-E 18-80mm T4.4 Compact-servo
- Canon CN-E 70-200mm T4.4 Compact-servo

**NOTE** Analog B4 lenses with servos are also supported although the camera will only power the zoom servo and support electronic iris control. Many of them are standard definition and may not have the standard 12 pin broadcast connector. If you are going to use an analog B4 lens, it's important to make sure it is compatible with your camera first as some have limited feature sets. It is also worth testing them for their image circle coverage as some of them may fall off drastically for resolution and light towards the edge of the frame.

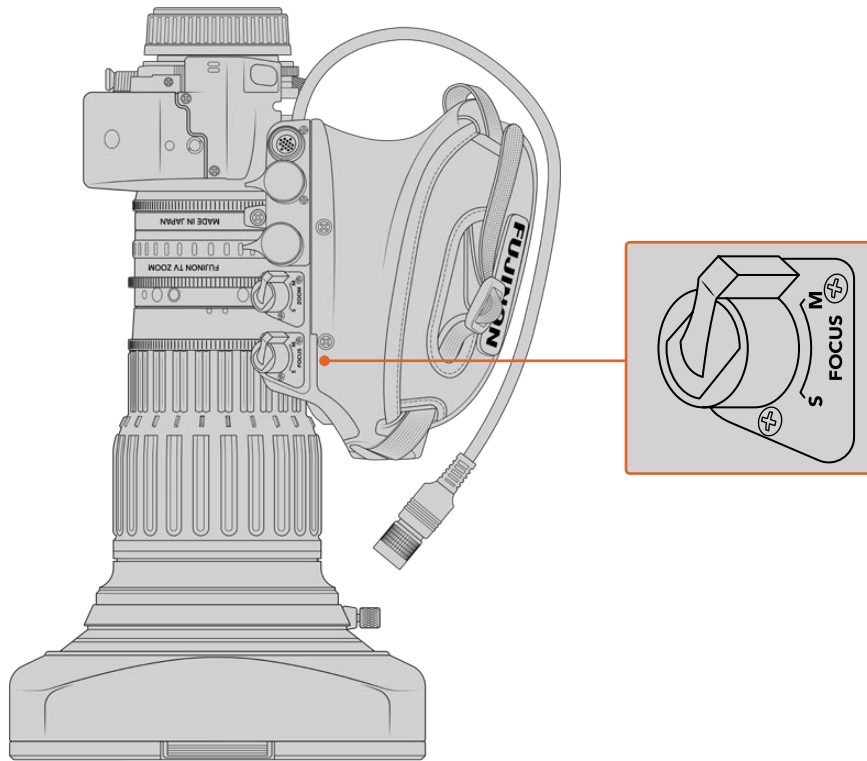

## Ret and VTR

On a B4 lens, the 'vtr' button toggles recording and the 'ret' button is for 'program return'. For information on how you can configure the 'vtr' and 'ret' button as function buttons on URSA Mini Pro 4.6K G1, see the 'set function button' section.

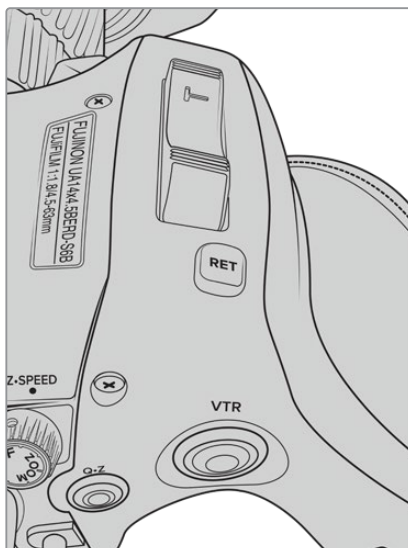

The 'ret' and 'vtr' buttons on a B4 lens

# Camera Video Output

## HD Monitoring Output

Blackmagic URSA Mini's down converted 3G-SDI out connector always outputs 1080 HD video so you can easily connect to routers, monitors, SDI capture devices, broadcast switchers and other SDI devices. This output is labeled 'front SDI' in the touchscreen settings menu.

## 12G-SDI Output

The 12G-SDI out connector on the rear panel supports HD and 4K video including high frame rate progressive formats such as 2160p50, 59.94 and 60 on a single SDI cable. Interlaced HD formats are also supported including 1080i50, 59.94 and 60. You can use the 12G-SDI output to connect to any SDI monitor as well as 4K switchers such as ATEM Production Studio 4K. This output can be switched between HD and Ultra HD by selecting 1080p or 2160p in the 'SDI output' setting for the 'main SDI' on the 'monitor' tab on the touchscreen.

### Connecting to Video Switchers

The SDI outputs allow you to use your camera for live television production. You can connect the rear panel SDI output directly to production switchers for live production work, or to ATEM Camera Converters to convert your signal to optical so you can send it hundreds of meters to a broadcast truck on location.

When connected to a switcher, you can easily view the switcher's program output on your Blackmagic URSA Mini. To do this, first connect the switcher to your camera's rear 12G-SDI input. Now press and hold the 'program' button marked PGM on your camera's fold out monitor to view your program feed. Release the PGM button to return to your camera feed. Double clicking the PGM button will lock the input to the program feed. To switch back to the camera feed press the PGM button once.

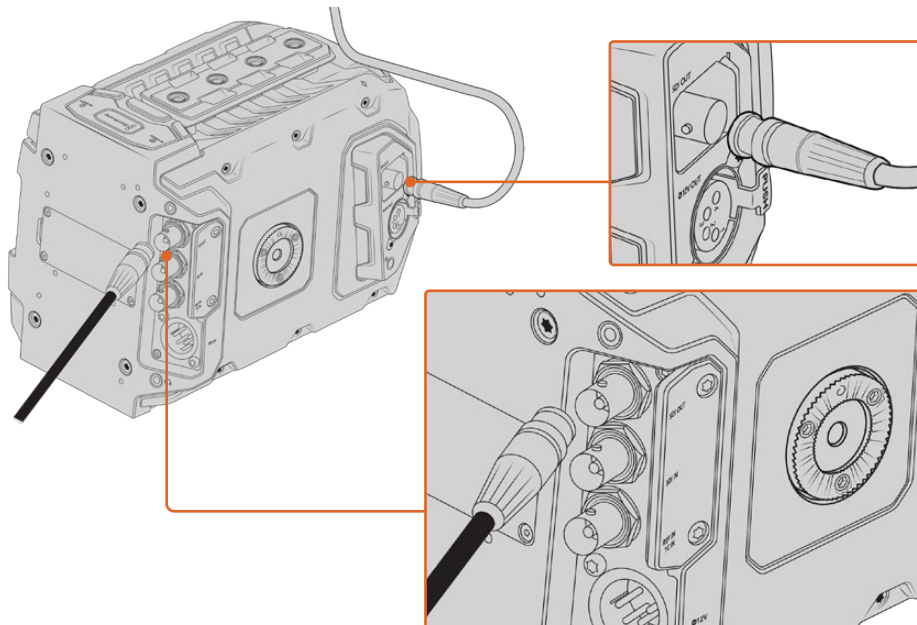

You can connect the 12G-SDI output to any 1080 HD or Ultra HD live production switcher or monitor. The HD monitoring output can be plugged into an external viewfinder, such as the Blackmagic URSA Viewfinder, or plugged into an external monitor when mounted to production equipment. For example a jib arm or crane

### Connecting to Monitors

SDI monitoring can be really handy when accessing the fold out monitor is impractical, such as when secured high on a jib arm, on a crane, or mounted on a vehicle.

Monitoring information is displayed via your HD-SDI monitoring out connector by adjusting the settings for the 'front SDI' on the 'monitor' tab on the touchscreen. These settings enable frame guides and information such as recording details and camera settings. If you simply want to monitor your shots, you can always turn overlays off for a clean SDI output.

Connect the camera's SDI output to SDI monitors or to a Blackmagic SmartScope Duo 4K for live waveform monitoring.

**NOTE** The rear SDI output and 3G-SDI monitoring output automatically flag HDR video with ancillary metadata when you are working in 'Film' dynamic range and use the 'Broadcast Film to Rec.2020 Hybrid Log Gamma' or 'Broadcast Film to Rec.2020 to PQ Gamma' LUT on the SDI output. This means you can display stunning HDR images on HDR enabled screens from either SDI output.

### SDI Output Formats

<b>Rear SDI Output</b>	2160p23.98, 24, 25, 29.97, 30, 50, 59.94, 60. 1080p23.98, 24, 25, 29.97, 30, 50, 59.94, 60. 1080i50, 59.94, 60.
<b>3G-SDI Monitoring Output</b>	1080p23.98, 24, 25, 29.97, 30, 50, 59.94, 60. 1080i50, 59.94, 60.

**TIP** To make a live recording with two codecs at once or a simultaneous backup, you can feed the rear SDI out from URSA Mini to a Blackmagic Video Assist or HyperDeck.

# URSA Mini Shoulder Mount Kit

## Attaching the shoulder mount

The URSA Mini Shoulder Mount Kit lets you carry URSA Mini on the shoulder for ENG style shooting. This kit includes a top handle, shoulder mount baseplate, extension arm for the optional Blackmagic URSA Handgrip, long LANC cable, Viewfinder adapter plate, plus all the required screws.

The quick release mount on the baseplate lets you lock your camera into an ENG style tripod plate or place it on your shoulder so you can follow the action.

The URSA Mini Shoulder Mount Kit works with any tripod plate modeled after the Sony VCT 14. These mounts are easily found at camera stores or online.

It's also worth mentioning that mounts modeled after the VCT U14 tripod plate are a different system and are not compatible.

### When attaching the shoulder mount kit, you will need the following tools:

- 1 x flat head screwdriver for the 2 x ¼" shoulder mount base plate screws.
- 1 x 3/16" Hex key driver for the 2 x ¼" top handle screws.
- 1 x 2.5mm Hex key driver for the 4 x Viewfinder adapter plate M3 screws.

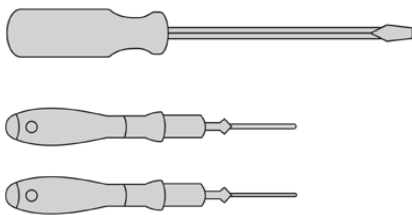

To attach the shoulder mount kit to your URSA Mini you will need a large flat head screwdriver, a 3/16" Hex key driver for the top handle and a 2.5mm Hex key driver for the Viewfinder adapter plate

## To attach the shoulder mount baseplate

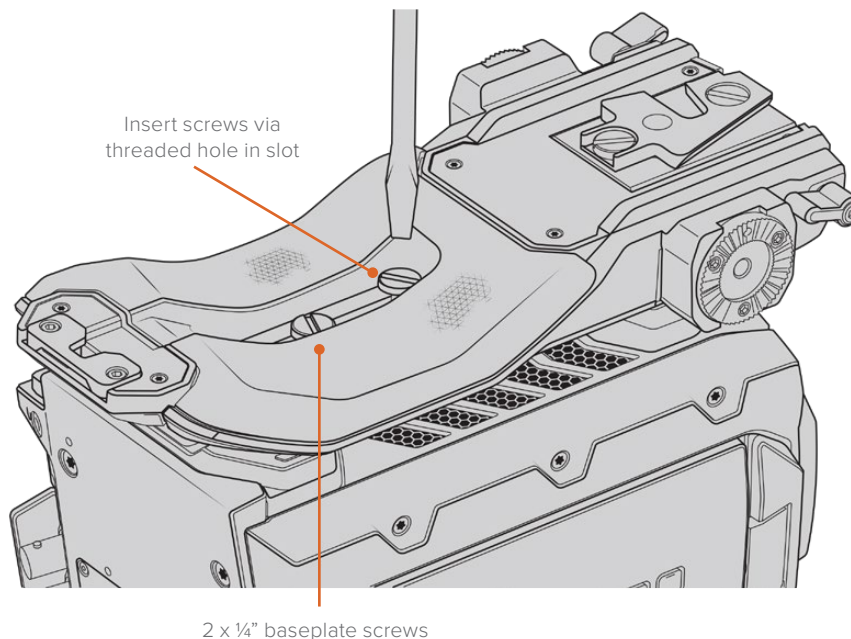



- 1 Gently place your URSA Mini upside down on a flat, stable surface so you can easily access the base of your camera.
- 2 Fasten the shoulder mount baseplate to URSA Mini using the 2 x ¼" flat head screws and driver.
- 3 Tighten the screws until the baseplate is firmly attached and the screws won't loosen. Avoid over-tightening as it may damage the screw threads.

## To attach the top handle without URSA Viewfinder

You can use URSA Mini Shoulder Mount Kit with or without the optional URSA Viewfinder.

The top handle is supplied with a rubber viewfinder cap on its base which is replaced with an adapter plate when attached to the URSA Viewfinder. We recommend leaving the cap attached when using the handle without the URSA Viewfinder.

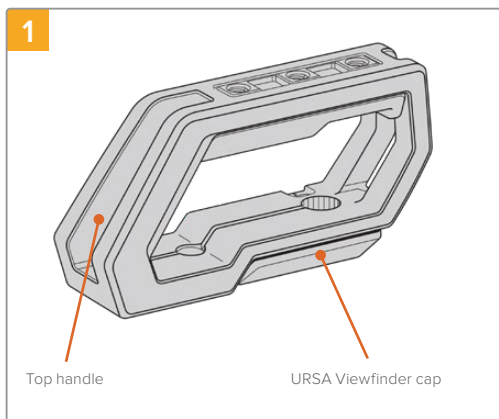

Place your URSA Mini on a flat, stable surface so you can access the top of your camera.

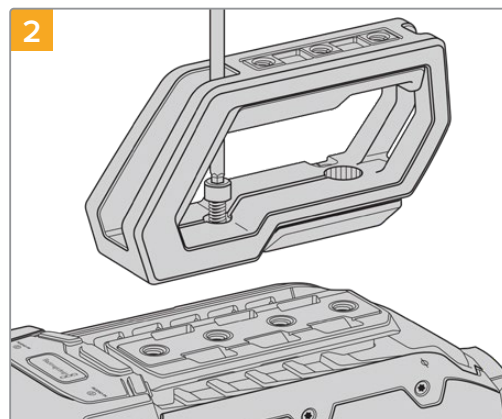

Fasten the handle to any two of your URSA Mini's top ¼" mounting points using the two supplied ¼" screws with a 3/16" Hex key driver. URSA Mini's rear two mounting points are recommended for most situations, but you can choose any pair for better weight balance when using large lenses.

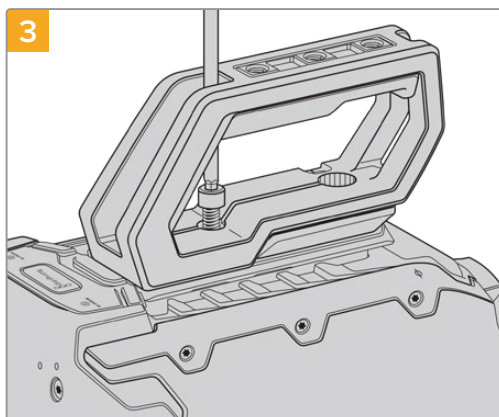

Tighten the screws until the handle is firmly in place and the screws won't easily loosen. Avoid over-tightening the screws as it may damage the screw threads.

## To attach the top handle with URSA Viewfinder

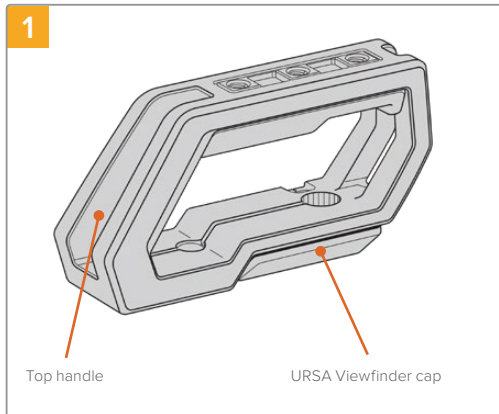

Place your URSA Mini on a flat, stable surface so you can access the top of your camera.

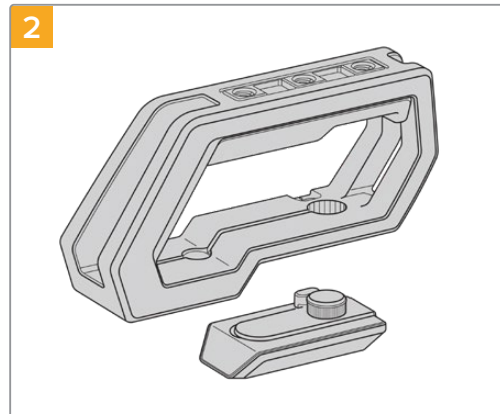

Remove the URSA Viewfinder cap from the base of the handle by gently lifting its arm away from the side of the handle and pulling the cap from the hole.

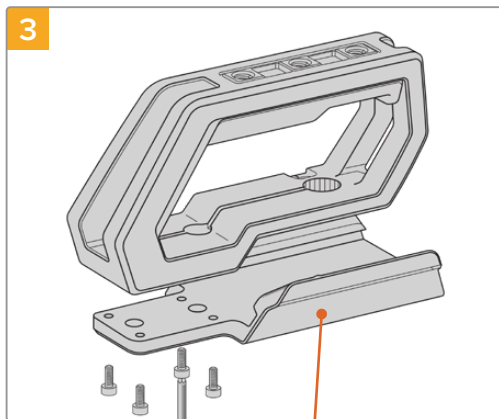

Fasten the URSA Viewfinder adapter plate to the handle using the 4 x M3 screws with a 2.5mm Hex key driver.

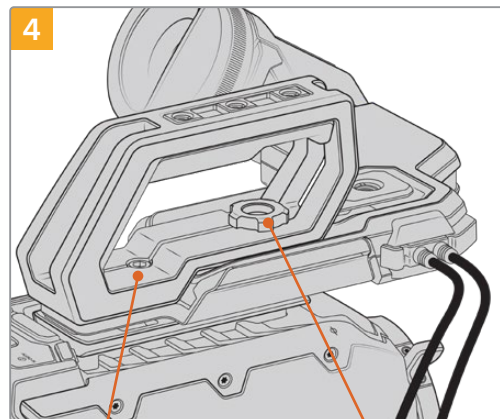

Fasten the handle to any two of URSA Mini's top 1/4" mounting points using the two supplied 1/4" screws with a 3/16" Hex key driver. URSA Mini's rear two mounting points are recommended for most situations, but you can choose any pair for better weight balance when using large lenses. Avoid over-tightening the screws as it may damage the screw threads.

The hole inside the front of the handle is used with the thumb screw when attaching and adjusting the URSA viewfinder. For information on how to attach the URSA Viewfinder to the top handle, refer to the 'Blackmagic URSA Viewfinder' section in your URSA manual.



## Attaching the extension arm

When using the URSA Mini shoulder mount kit with the Blackmagic URSA Handgrip, you'll need to reposition the handgrip for comfortable shoulder based shooting. Use the bundled extension arm and longer LANC cable to move the handgrip to a more ergonomic position. The URSA Mini extension arm is also available as a separate accessory from Blackmagic Design resellers.

### To attach the extension arm:

- 1 Place your URSA Mini on a flat, stable surface allowing room next to the camera to lower the extension arm. Mounting URSA Mini to a tripod is helpful for this purpose.
- 2 Attach the indented end of the extension arm to the baseplate rosette, lower the arm to suit, and fasten with the supplied rosette thumbscrew.
- 3 Attach the handgrip to the extension arm's front rosette. Fasten by tightening the handgrip screw with the large flat head screwdriver, or by twisting the D ring with your thumb and forefinger.
- 4 Connect the Blackmagic URSA Handgrip's LANC output to the camera LANC input using the long LANC cable supplied with your shoulder mount kit.

You can easily adjust the extension arm and Blackmagic URSA Handgrip to suit your preference by loosening the rosette screws, making your adjustment, then retightening.

With your URSA Mini Shoulder Mount Kit now attached, you have additional speed for fast shooting on the run, plus the ability to quickly mount your camera on a tripod for tight, stable shots!

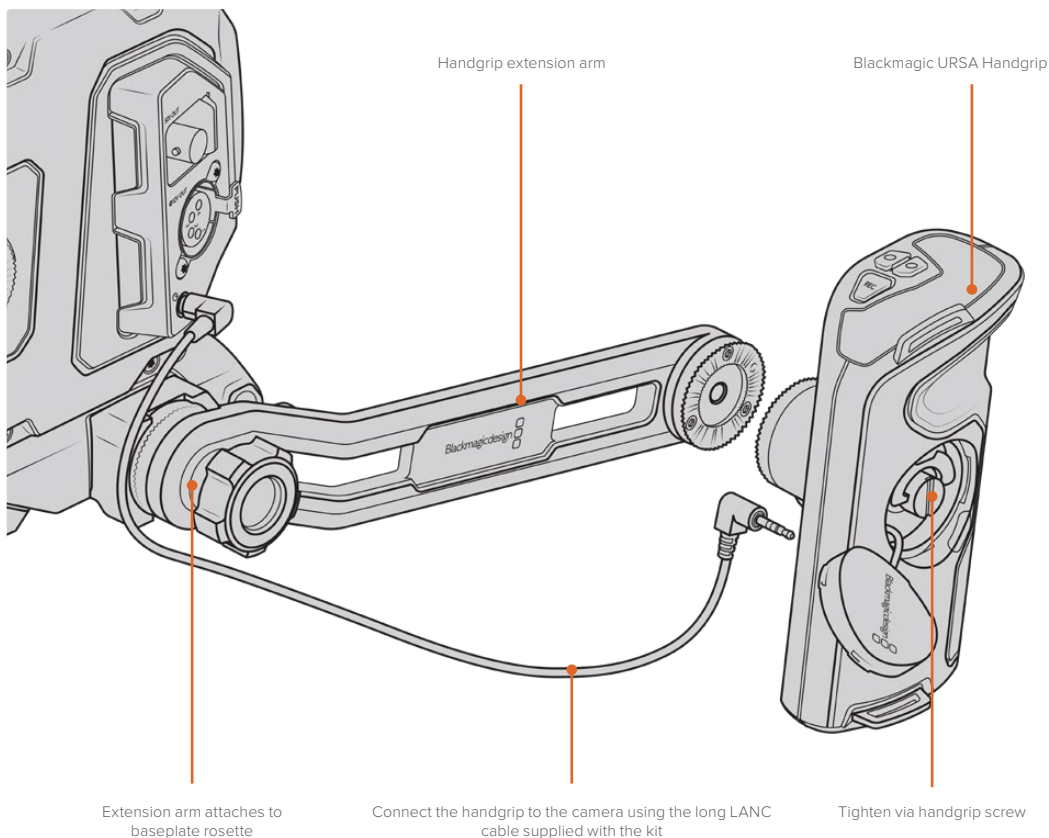

# Blackmagic URSA Viewfinder

Blackmagic URSA Viewfinder is a powerful electronic viewfinder designed for your Blackmagic URSA Mini. The 1080HD color OLED display and precision glass optics provides a bright, vivid, and lifelike image so you can quickly find focus and see the finest detail in your images.

This viewfinder is perfect for handheld operation on the shoulder, or for environments where you need absolute precision with zero reflection and light glare, for example in extremely bright shooting conditions.

The viewfinder is connected and powered by the camera and uses the embedded SDI data from the camera to generate the various display options. This means that your camera can output a clean SDI feed to the viewfinder but still allows you to toggle various display options within the viewfinder for quick access to camera status, plus accurate information.

For example, if you select the '2.40:1' frame guide option in URSA Mini's menu, it will actually tell the viewfinder which frame guide is selected in the camera so when you toggle the frame guide display on the viewfinder, the same '2.40:1' frame guide is also displayed.

## Mounting and Connecting to Blackmagic URSA

To attach the Blackmagic URSA Viewfinder to the camera body, slide it along the handle ridges and tighten the thumb screw to one of the 1/4" mounting points.

Blackmagic URSA Mini Shoulder Mount Kit is required to mount URSA Viewfinder correctly on URSA Mini and URSA Mini Pro.

To attach Blackmagic URSA Viewfinder, remove the URSA Viewfinder cap from URSA Mini Shoulder Mount Kit top handle and install the Viewfinder adapter plate, as detailed in the 'URSA Mini Shoulder Mount Kit' section in this manual.

Slide URSA Viewfinder mount into the URSA Viewfinder adapter plate and use the 1/4" thumbscrew included in URSA Mini Shoulder Mount Kit to secure URSA Viewfinder to the top handle and adapter plate.

There is no need to use any tools to secure the thumbscrew, finger pressure is sufficient and will prevent over tightening.

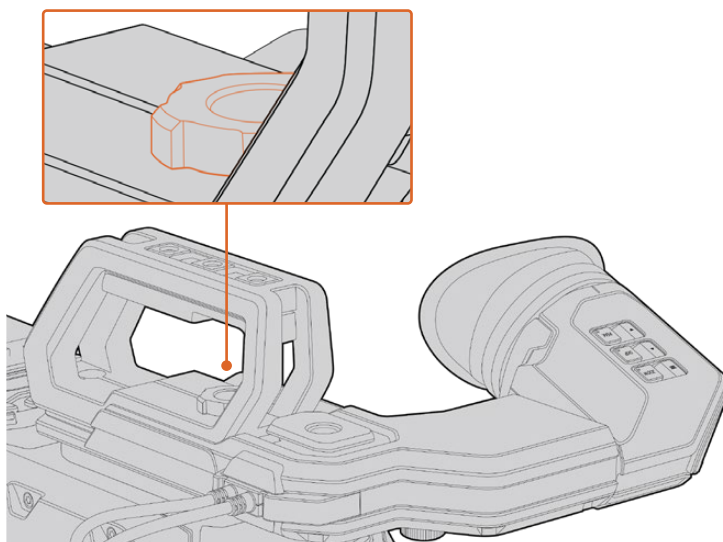

To mount your Blackmagic URSA Viewfinder to your URSA Mini, slide the viewfinder mount along your camera's handle ridges and tighten the thumbscrew to a 1/4" mounting point

To connect your URSA Viewfinder to your URSA, simply connect the viewfinder's attached cables to URSA's front 12V power and 3G-SDI outputs. Your URSA Viewfinder will turn on automatically when your camera is powered.

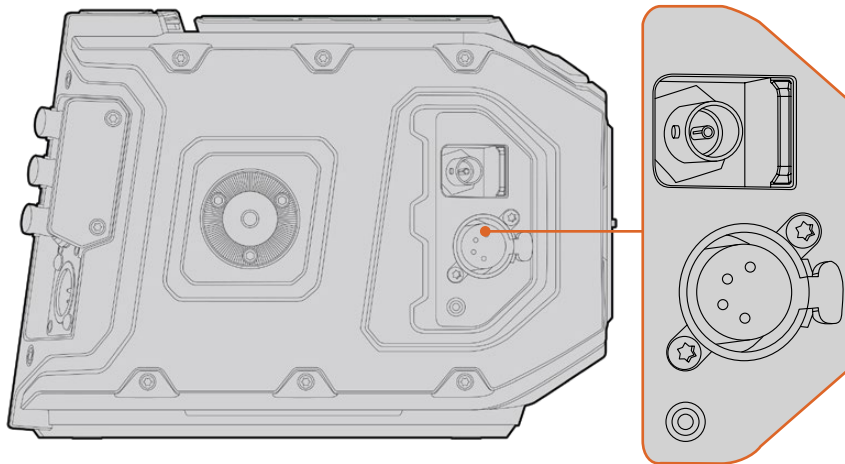

Connect your viewfinder's SDI and power cables to your URSA Mini HD-SDI monitoring output and +12 volt output

When using the URSA Viewfinder with URSA Mini, it is highly recommended that you also install the URSA Mini shoulder mount kit as this provides the correct mounting points, 1/4" thumb screw, and height adjustments to optimize the positioning of your viewfinder. See the 'URSA Mini shoulder mount kit' section in this manual.

## Adjusting the Eyepiece

The detachable rubber eyepiece can be adjusted to fit your left or right eye. Adjust the viewfinder arm by loosening the knob on the bottom of the arm and sliding it left or right to comfortably fit your eye.

## Button Features

On the top of the viewfinder you'll find the zoom, display and peak buttons. These buttons are used for zooming into your image, and turning overlays and focus peaking on or off.

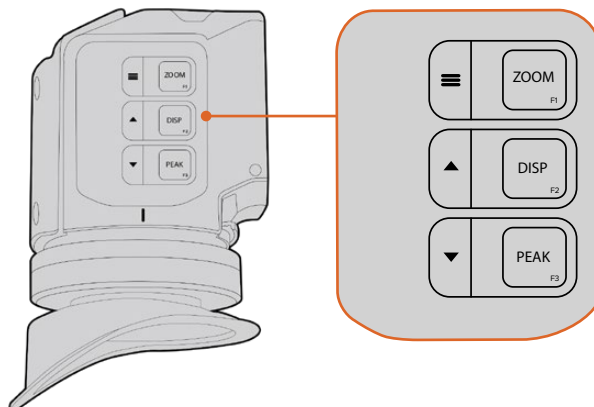

The Zoom (F1), Display (F2) and Peak (F3) buttons are located on top of the URSA Viewfinder

They are also used for additional features, such as opening the menu and navigating settings. Icons printed on the side of the buttons show you which buttons are used to control the viewfinder menu and navigation features.

The buttons also have a customizable function feature so you can assign shortcuts to quickly enable common features you may use frequently. For example you may wish to assign the false color feature to the zoom button. Refer to the 'shortcuts' section for more information.

### **ZOOM (F1) - 'menu'**

The 'zoom' feature helps you find sharp focus by zooming into your picture. Press the 'zoom' button to zoom in and press again to return to 100% view. When using the settings menu, the 'zoom' button also serves as the 'menu' button. Press and hold this button to open the settings menu. In the settings menu, press this button once to confirm setting changes.

### **DISPLAY (F2) - 'up'**

Press the 'display' button to see the overlay view. When using the settings menu, this button also serves as the 'up' button. You can also quickly open the 'shortcuts' menu setting by pressing and holding this button. Refer to the 'shortcuts' section for information on how to set shortcuts.

### **PEAK (F3) - 'down'**

The focus peaking feature creates a green edge around the sharpest parts of the image so you can easily confirm your focus. Press the 'peak' button to turn the peaking feature on. Press again to turn peaking off. When using the settings menu, this button also serves as the 'down' button. You can also quickly open the 'setup' menu by pressing and holding this button.

## Menu Settings

The settings menu contains three primary menu headings for display, shortcuts, and setup. To open the settings menu, press and hold the 'menu' ≡ button. Press the 'up' ▲ and 'down' ▼ button to navigate between the settings and press the 'menu' ≡ button again to confirm your selection.

### Display

The 'display' menu provides the following features:

#### **B&W**

Switches between color and monochrome.

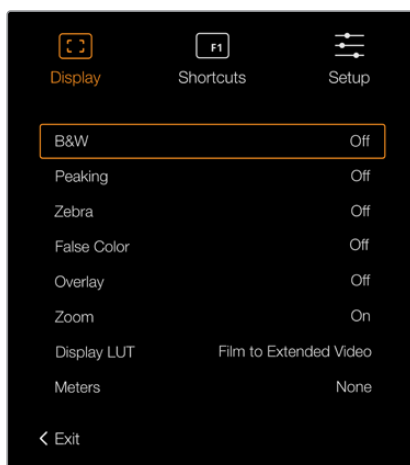

The 'display' menu in URSA Viewfinder

#### **Peaking**

Switches peaking on and off.

## Zebra

Switches zebra levels on and off. Set your desired zebra levels using the camera settings. For more information, refer to the 'settings' section in this manual.

## False Color

Switches the false color feature on and off. False color overlays different colors onto your image that represent exposure values for different elements in your image. For example, pink represents optimum exposure for light skin tones, while green is a good match to darker skin tones. By monitoring the pink or green false color when recording people, you can maintain consistent exposure for their skin tones. Similarly, when elements in your image change from yellow to red, that means they are now over exposed.

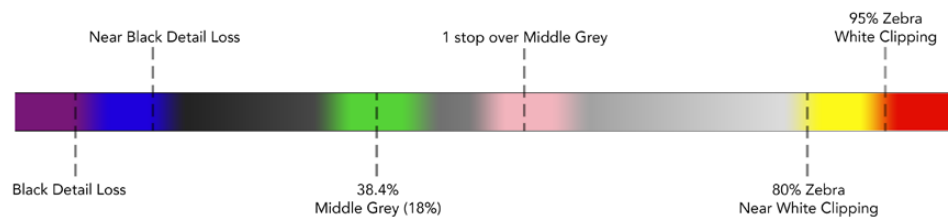

False Color Chart

## Overlay

Switches overlays on and off. You can select which types of overlay to display in your viewfinder's 'setup' menu. The style of these overlays, such as the safe area percentage, are set in your camera.

## Zoom

Turns the zoom feature on and off.

## Display LUT

When sending a 'film' dynamic range SDI signal from your URSA Mini, the 'film to video' and 'film to extended video' settings allow you to apply a more colorful and contrasty LUT to the image. The viewfinder will detect when either of these LUTs are being used and will give you the option to toggle them on or off in your viewfinder. When a display LUT is active on the front SDI output, or you are using a different LUT, the option is disabled to prevent multiple LUTs being applied.

## Meters

Switches between the types of meters to display in overlay view. The options are 'histogram', 'audio', 'both' or 'none'.

## Shortcuts

The shortcut function is useful when you need to quickly access a particular setting for a frequently used feature. To customize your shortcut buttons:

- 1 In the 'shortcuts' menu, press the 'up' ▲ or 'down' ▼ button to move up or down and select one of the 3 buttons to make it your shortcut button. Press the 'menu' ≡ button to confirm your selection.
- 2 Press the 'up' ▲ or 'down' ▼ button to toggle and select one of the features below to assign to the shortcut button. Press the 'menu' ≡ button to confirm your selection.
  - B&W
  - Peaking
  - Zebra
  - False Color
  - Display
  - Zoom
  - Display LUT
  - Meters

- 3 Scroll to 'exit' and press the 'menu' ≡ button to close the menu display view.

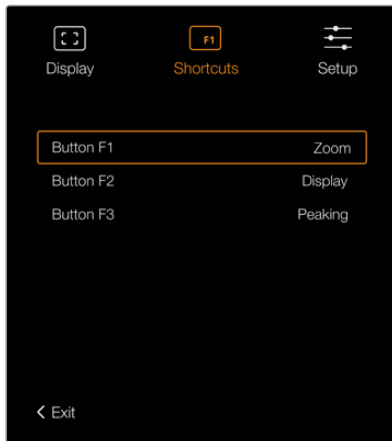

The 'shortcuts' settings in URSA Viewfinder

## Setup

The 'setup' menu provides the following features:

### Brightness

Allows adjustments for the brightness of the display with range -10 to +10.

### Tally Brightness

Allows adjustments of tally LED brightness.

### Focus Chart

Your Blackmagic URSA Viewfinder has a built in focus chart so you can focus the eye piece to suit your eyes. Simply turn the focus diopter on the eyepiece until the chart is in perfect focus. Pressing any button on your viewfinder will close the focus chart display.

### Frame Guide

Toggles the appearance of frame guides when set as an overlay. When 'frame guides' are turned 'on', your viewfinder will display the same frame guides set for 'all' outputs in your camera's 'monitor settings'. You can toggle the frame guide view on your viewfinder by selecting on or off.

For more information, see the 'Monitor Settings' section in this manual.

### Safe Area Guide

Toggles the appearance of a safe area guide when the 'overlay' is set to 'on'. When 'safe area guide' is turned 'on' in your URSA Mini's 'all' monitor settings, you can use this setting to toggle the safe area guide on or off.

For more information, see the 'Monitor Settings' section in this manual.

### Grid

Toggles the appearance of a rule of thirds grid, crosshair or center dot. When 'grids' are turned 'on' in your URSA Mini's 'all' monitor settings, you can use this setting toggle their appearance in your Blackmagic URSA Viewfinder when overlays are on.

For more information, see the 'Monitor Settings' section in this manual.

**NOTE** Enabling 'Grid' in your URSA Viewfinder setup menu will also allow your viewfinder to display tally signals sent from an ATEM switcher. Overlays must also be set to 'on' in the display menu.

### Status Text

Toggles the appearance of status text, such as white balance, frame rate and ISO. When 'status text' is turned 'on' in your URSA Mini's 'front SDI' monitor settings, you can use this setting to toggle its appearance in your Blackmagic URSA Viewfinder.

For more information, see the 'Monitor Settings' section in this manual.

**TIP** When using Blackmagic Viewfinder with URSA Mini, the appearance of status text can clash if both the viewfinder and camera are set to show status text. In this situation, we recommend turning status text to 'on' in your camera, and status text to 'off' in your viewfinder.

### IR Sensor

The IR Sensor on your viewfinder automatically detects when you are near the eyepiece and turns on the OLED display. If you are away from the viewfinder for over twenty seconds in standby mode, display turns off to conserve power and to extend the life of the OLED display. While recording, the timeout sensor is extended to 5 minutes, at which point the OLED display will be slowly dimmed. Any movement in front of the eyepiece will reset this timer. The viewfinder will detect when you look into the viewfinder eyepiece, pressing any button on the viewfinder will also turn the display back on.



Deliberately blocking or covering the IR sensor could cause the viewfinder's display to remain powered for prolonged periods of time. This could decrease the lifespan of the display and cause image retention if high contrast images or frame guides are displayed on the viewfinder.

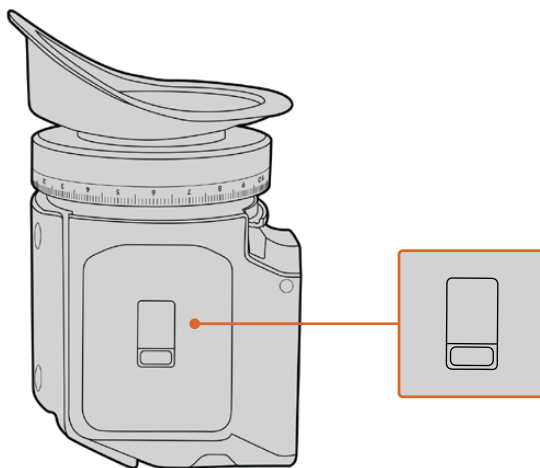

The IR sensor is located at the bottom of the URSA Viewfinder

## Updating URSA Viewfinder's Internal Software

Update your viewfinder using the Blackmagic Camera Setup Utility software. The viewfinder will need to be powered when updating, so we recommend keeping the viewfinder connected to your URSA Mini during the update process. This also means your URSA Mini will need to supply consistent power, so be sure to plug into external power.

Connect your computer to the small USB connection located at the front of your viewfinder, near the eyepiece. When Blackmagic Camera Utility is launched and your viewfinder is connected to your computer, you will be prompted to update if your computer detects that your viewfinder is using an older version. Follow the on screen prompts to update your viewfinder's internal software.

**NOTE** Refer to the 'Blackmagic Camera Setup Utility' section in this manual for more information.

**TIP** We recommend updating all your Blackmagic URSA equipment at the same time for optimized performance



# Blackmagic URSA Studio Viewfinder

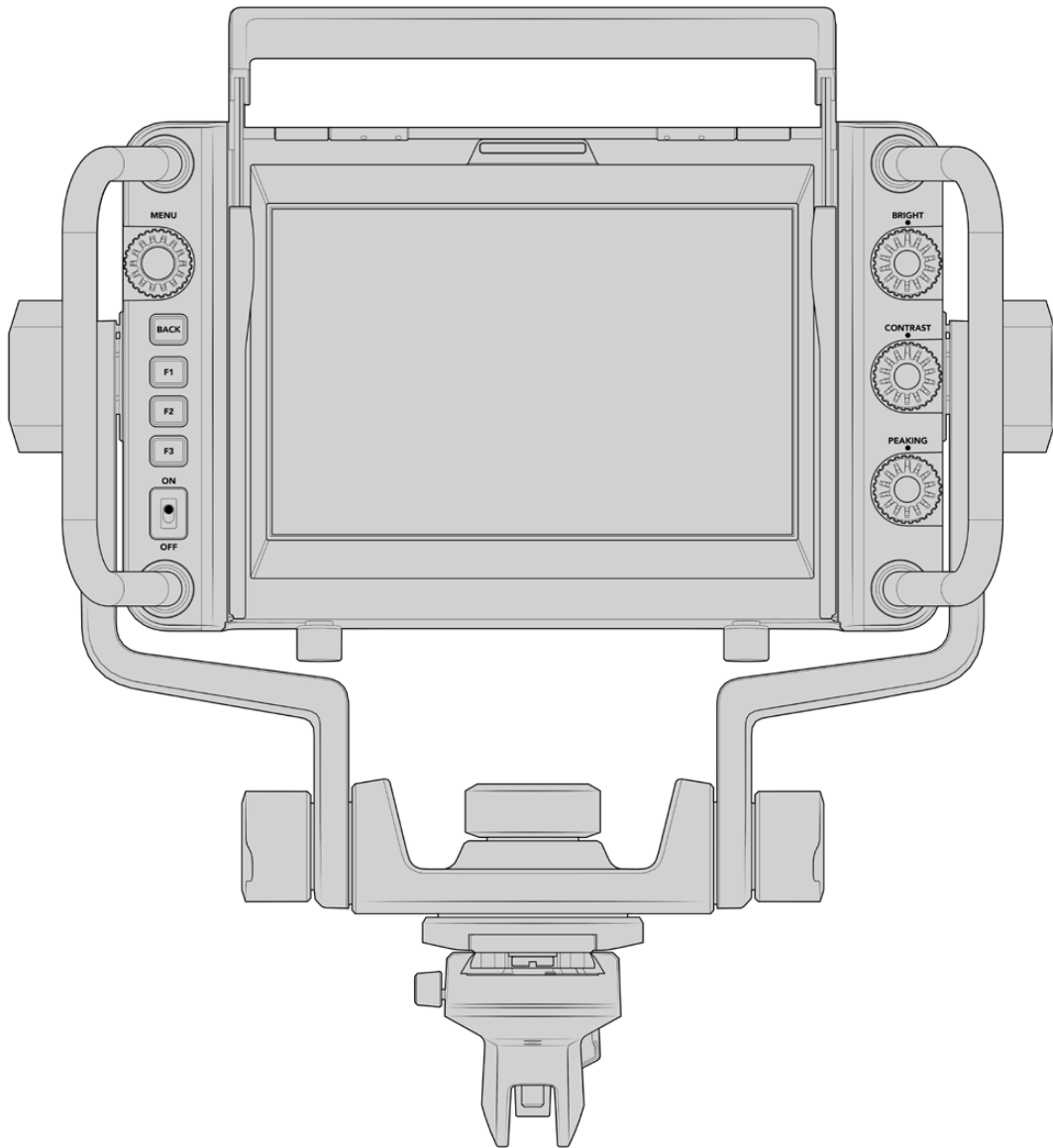

Blackmagic URSA Studio Viewfinder

Blackmagic URSA Studio Viewfinder is a powerful viewfinder that allows you to turn your Blackmagic URSA Mini into a professional live production camera. The studio viewfinder features a bright 7" screen and has a large easily viewable tally light, control knobs, large handles, sun hood and variable tension articulated mount. These features make it easy to stand behind the camera and comfortably follow the action for extended periods of time, especially when filming live concerts, sports, and other long events. The URSA Studio Viewfinder is perfect for professional live production in the studio or on location.

## Mounting and Connecting to Blackmagic URSA Mini

When using the Blackmagic URSA Studio Viewfinder with Blackmagic URSA Mini, you have the option of mounting the unit to the camera in a number of ways.

You can mount the Blackmagic URSA Studio Viewfinder directly to the top of Blackmagic URSA Mini via the supplied V-lock mount plate which can be easily removed from the top handle mount.

Unscrew the V-lock plate from the URSA Mini handle mount using a 3/16 Hex key, and then attach it to the top of the camera with the supplied 1/4" screws. As this will make the center of gravity on the camera much higher. We recommend doing this while the camera is attached to a tripod for stability.

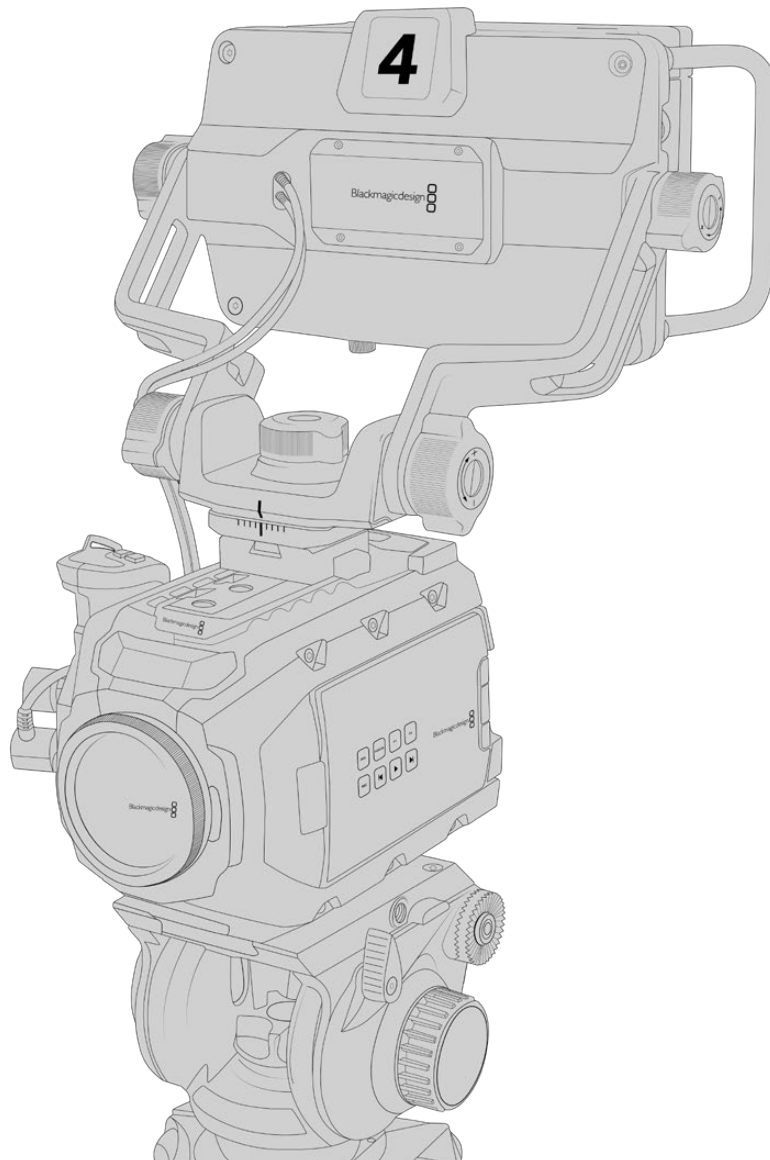

If you are mounting the Blackmagic URSA Studio Viewfinder to your URSA Mini whilst using the URSA Mini Shoulder Kit, you need to attach it using the supplied URSA Mini handle mount. Attach the supplied URSA Mini handle mount to the top handle with three of the supplied 1/4" screws using a 3/16 Hex key. Slide the Studio Viewfinder's V-lock into the V-lock plate slot until it clicks in securely.

See the 'URSA Mini Shoulder Mount Kit' section in this manual for more information.

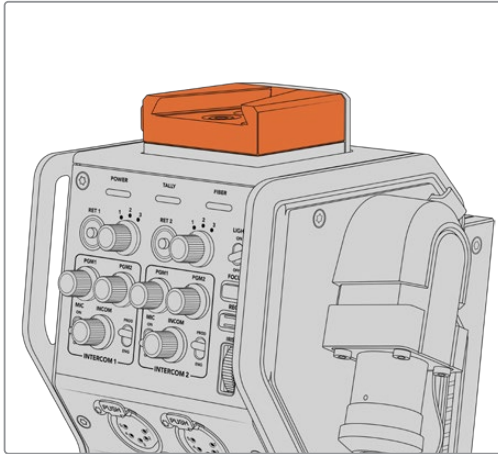

You can attach your Blackmagic Studio Viewfinder to the V-lock plate on the top of the Blackmagic Camera Fiber Converter

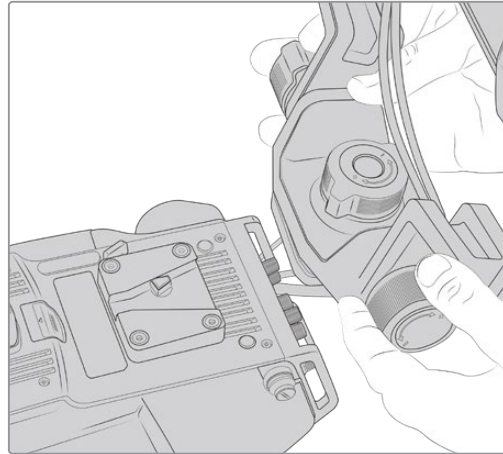

V-Lock mount plate being attached to 3rd party camera

The V-Lock mount plate can also be installed on any camera you want to use the URSA Studio Viewfinder with that has 1/4" mounting points, or by using a third party cheese plate. You can also mount the Blackmagic URSA Studio Viewfinder to a third party camera system that has an existing V-lock mount plate as many of them have this quick release plate on them already.

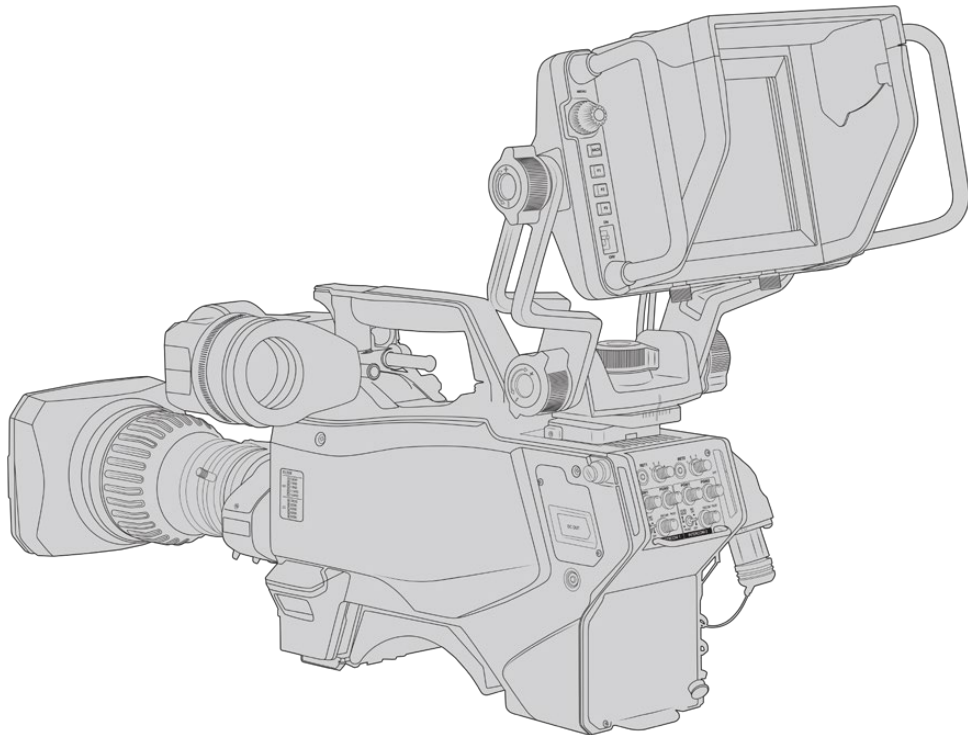

**TIP** The Blackmagic URSA Studio Viewfinder connects to the camera via a quick release V-lock mount plate, which means that the viewfinder can be removed quickly if you need to take the camera off a tripod. When filming sports matches it can be advantageous to leave both the Blackmagic URSA Viewfinder and Blackmagic URSA Studio Viewfinder attached to the camera, so that at the conclusion of the match you can quickly switch to the URSA Viewfinder for handheld filming. Both viewfinders use the same 12V power and 3G-SDI cables to connect to the camera, making it easy to swap cables in such a situation.

To connect your Blackmagic URSA Studio Viewfinder to your URSA Mini, simply connect the viewfinder's attached cables to URSA's front 12V power and 3G-SDI outputs.

The power switch on the viewfinder will then allow you to turn on the viewfinder instantly when your camera is powered. Note that there are cable clamps on the side of the URSA Mini handle mount to keep your cables neat and hold the cables in place.

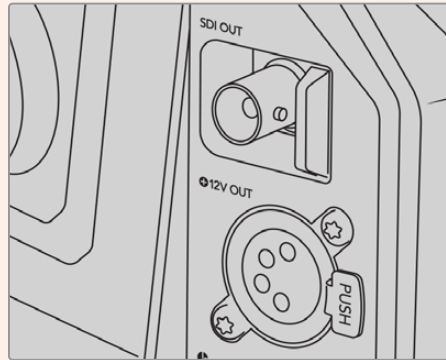

SDI and 12v power connections on URSA Mini

**TIP** The URSA Studio Viewfinder uses open standard SDI and broadcast 4 pin XLR power connections so it can be used with any other camera or even as an adjustable portable location monitor. It also uses the open standard ATEM tally and device control protocol so any other camera system can add this information to their SDI stream to allow them to work with the tally and overlays on the URSA Studio Viewfinder.

## Adjusting the Blackmagic URSA Studio Viewfinder

The Blackmagic URSA Studio Viewfinder features large handles and variable tension articulated mounting that allow you to adjust the position and angle of the viewfinder. The large handles allow you to quickly and easily take hold of the viewfinder and adjust the angle and direction of the unit. Combined with the sun hood the handles also help to protect the screen from damage, which means that you can store the fully assembled Blackmagic URSA Studio Viewfinder in a carry case without disassembly. The large handles also allow you easily to pick up and carry the unit between locations.

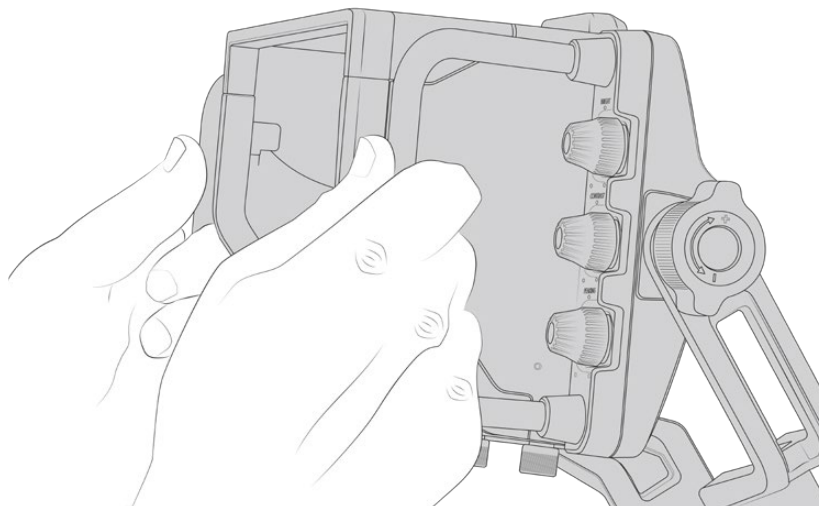

The supplied mount features tension dials for pan and tilt, with additional tension dials on either side of the viewfinder for additional friction control. The left hand dial allows you to adjust the drag friction of the arm and the right hand dial allows you to lock the Viewfinder in place once you have found the angle you require.

These tension dials have a very large range of tension adjustment, allowing you to select a specific amount of resistance. This allows you to easily pan and tilt the viewfinder to the precise position you require.

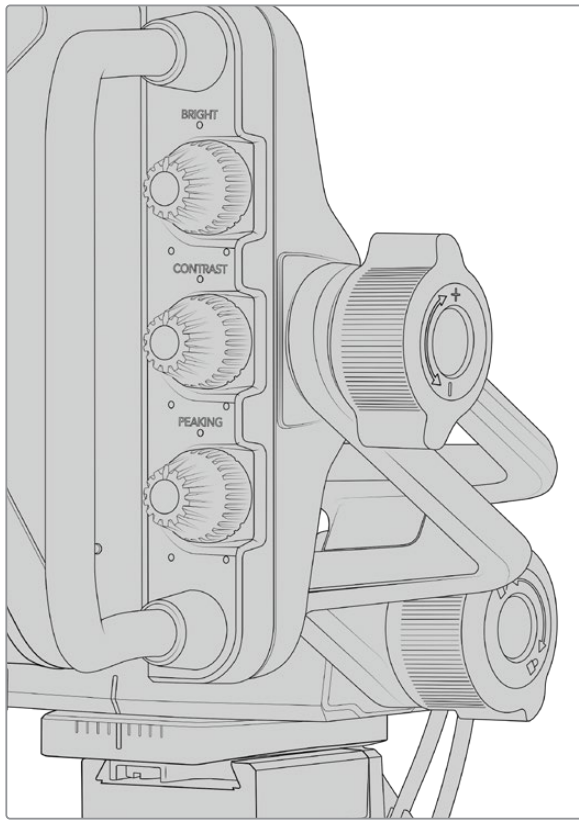

Tension dials on either side of the viewfinder

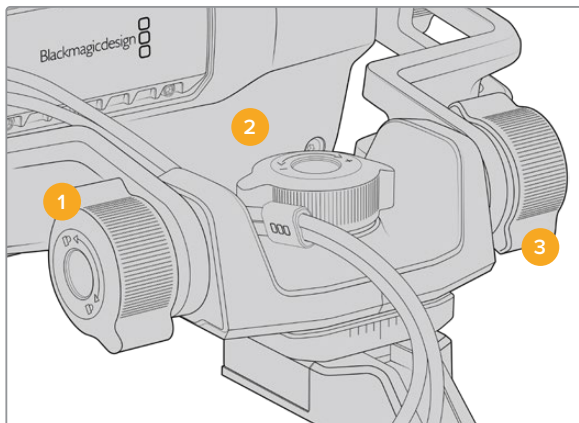

- 1 Tilt Lock Dial**  
Locks the angle of tilt on the viewfinder mechanism.
- 2 Pan Tension Dial**  
Controls pan tension.
- 3 Tilt Tension Dial**  
Controls tilt tension.

**TIP** The center tension dial on the supplied mount controls pan tension, and can be loosened to allow you to take hold of the viewfinder and move the camera independently. This means that you can film things like motorsport, where you need to pan the camera left and right to follow the action, whilst holding the viewfinder positioned towards your eyes. A visual guide on the mount helps to ensure that the viewfinder can easily be returned to the center.

## Sun hood

The sun hood helps you to see the screen in bright or sunny conditions. To attach the sun hood, slide it over the top of the Blackmagic URSA Studio Viewfinder and push it into place, securing it with the two captive screws on the base of the sun hood. The top section of the visor is adjustable, and can raise and lower to provide additional viewing angles. The sun hood provides additional protection for the 7" screen, and can be removed quickly and easily if desired or to access the USB-C connector for software updates.

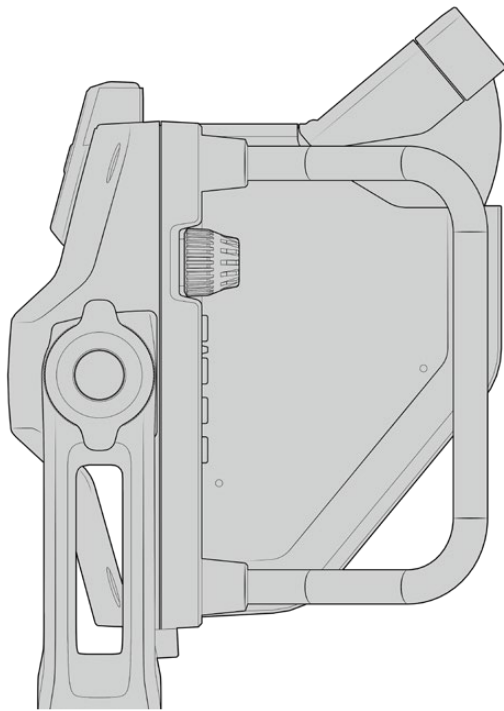
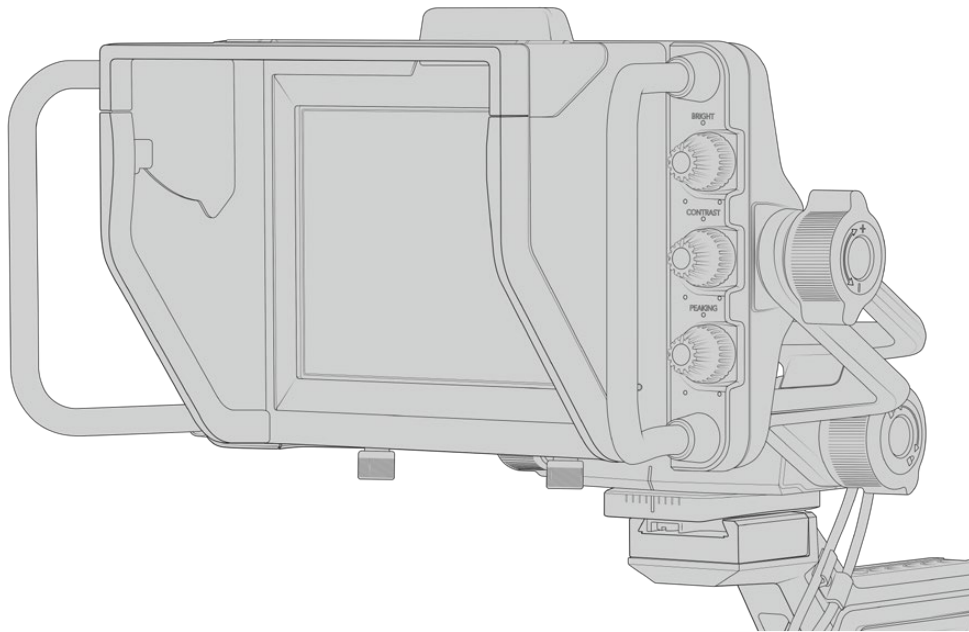

Sun hood and adjustable visor

## Button Features

The tactile dials down the right hand side let you change brightness, contrast, peaking quickly and easily. The dials are ergonomically designed so you can adjust the dials from the side with your thumb when using the sun hood, or with two fingers for finer more controlled adjustment.

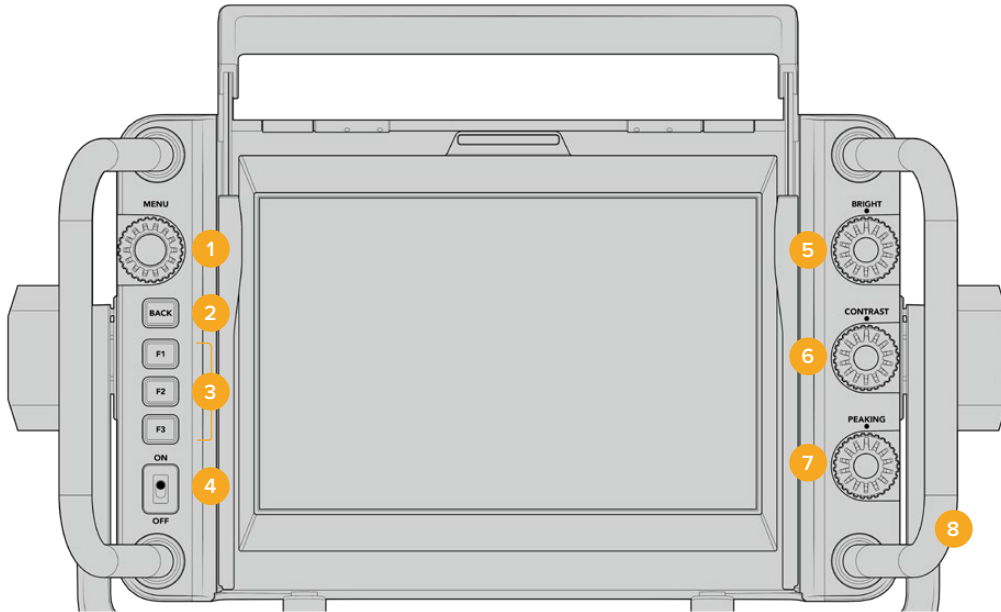

### 1 Menu Dial

The push button 'menu' dial allows you to enter the menu, and navigate through the viewfinder settings.

### 2 Back button

Exits the menu system

### 3 F1, F2, F3

Assignable function buttons. You can assign functions to these buttons for easy access to your most commonly used functions.

### 4 ON/OFF switch

Switches the Blackmagic URSA Studio Viewfinder on and off.

### 5 Bright

Adjusts the brightness of the image on screen. Overlays on screen will show the brightness level on a scale of -100 to +100.

### 6 Contrast

Adjusts the contrast of the image on screen. Overlays on screen will show the contrast level on a scale of -100 to +100.

### 7 Peaking

Adjusts the focus peaking level for the image on screen. Overlays on screen will show the peaking level on a scale of -100 to +100. In the setup menu you can select between various styles of peaking to suit your environment.

There is the option for the traditional style of focus peaking that many will be familiar with from other broadcast systems, as well as the option to use colored lines for focus. As with URSA Mini you have the option of 'red', 'green', 'blue', 'black' and 'white' lines which gives you flexibility to make them easily viewable when shooting in environments that have a lot of a particular color.

### 8 Handles

The built in handles are large and allow you to hold the Studio Viewfinder in place as you reposition the camera while shooting. They also provide protection for the screen when setting up and packing down.



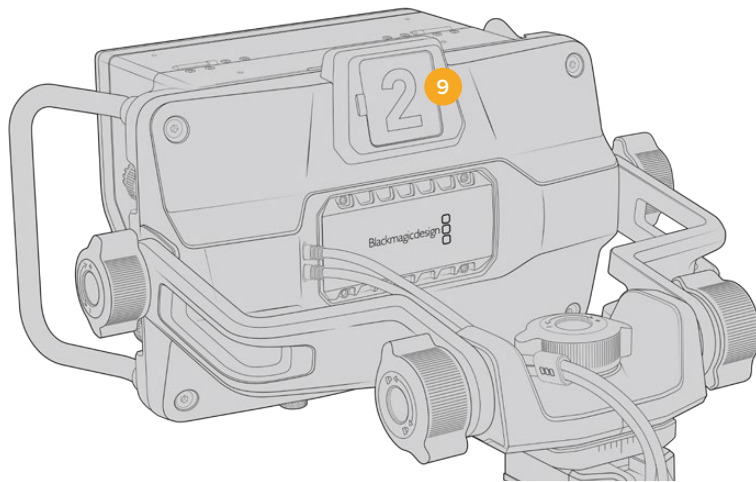

## 9 Tally Light

The large tally light on the rear of the Blackmagic URSA Studio Viewfinder lets both the talent and operator know which camera is on the air, which camera is about to be on air, and if they are ISO recording. The tally illuminates red for on-air, green for preview and when used with URSA Mini will illuminate orange for ISO record.

As the director cuts between cameras on the ATEM switcher, tally information is sent back to the camera over SDI so the light is lit when the camera is being previewed to switch to, on the air or recording. In addition, the URSA Studio Viewfinder also includes clip-on transparent camera numbers that attach to the tally light, making it easy for talent to clearly see camera numbers from up to 20 feet away.

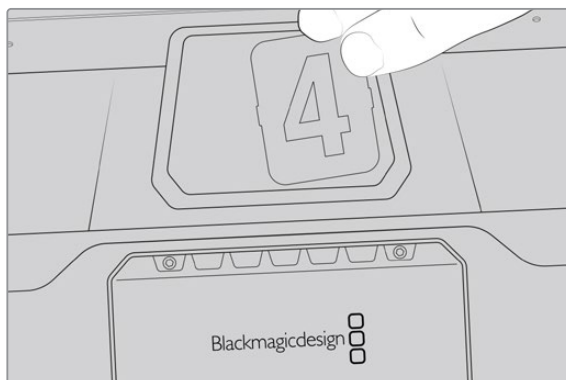

We have included editable PDF's in the software installer that allows you to edit and print out your own tally numbers to match the ones provided, and also to create your own custom tally number inserts. After installing Camera 4.1 software these can be found on a Mac in the Application > Blackmagic Cameras > Documents folder and on a PC in the Blackmagic Design > Documents folder.

The tally light will illuminate according to the ATEM switching operations, and when the camera is not connected to a switcher the tally light will illuminate red as a simple record tally indicator. Refer to the 'understanding studio camera control' section in this manual for more information.

**TIP** When using the Blackmagic URSA Studio Viewfinder with an ATEM switcher, it is important to select 'clean feed' on URSA Mini to ensure that you don't see overlays or the focus box on the SDI output to the ATEM switcher. Navigate to the 'monitor' menu on URSA and select 'clean feed' for 'main SDI'.



## Menu Settings

The push button 'menu' dial allows you to enter the menu by pressing it, whilst rotating the dial navigates up and down through the menu options. Pressing the 'menu' dial whilst a menu heading is highlighted, will allow you to switch between the display, shortcuts, setup and cursor sub menus. Rotating the dial will scroll through the settings in each menu. Pressing the dial when a setting is highlighted allows you to adjust that setting by rotating the 'menu' dial. Confirm your selection by pressing the 'menu' dial once more. You can exit out of the menu by hitting the 'back' button or by navigating to and selecting exit.

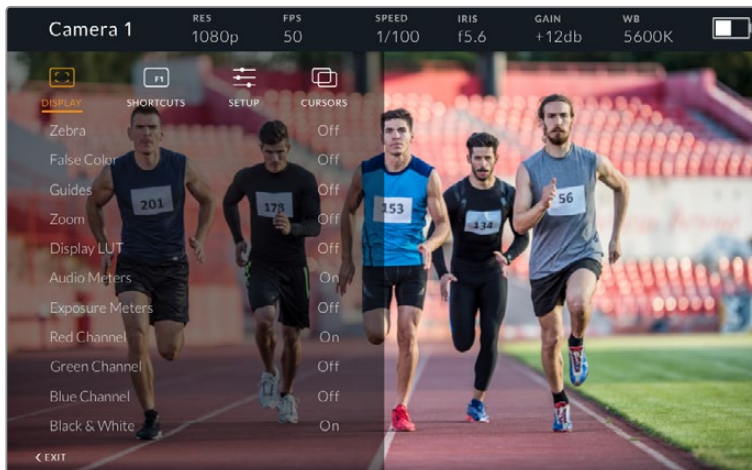

### Display

#### Zebra

Switches zebra levels on and off. The level of zebra will be determined by the setting on your URSA Mini, in the 'All' section of the 'Monitor' menu. When the Studio Viewfinder is not connected with URSA Mini, the zebra level will represent 95% of the luminance levels of a Rec 709 signal. For more information, refer to the 'settings' section in this manual.

#### False Color

Switches the false color feature on and off. False color overlays different colors onto your image that represent exposure values for different elements in your image. For example, pink represents optimum exposure for light skin tones, while green is a good match to darker skin tones. By monitoring the pink or green false color when recording people, you can maintain consistent exposure for skin tones. Similarly, when elements in your image change from yellow to red, that means they are now over exposed. False color is a good feature to assign to one of the function buttons, as it provides quick and easy access to a commonly used reference tool for exposure.

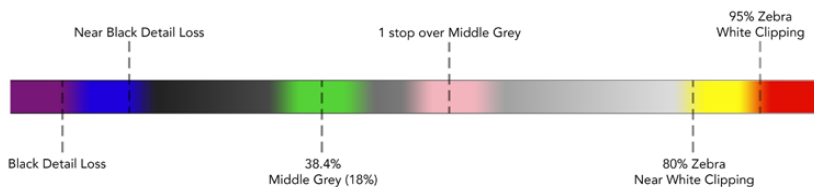

False Color Chart

#### Guides

This setting gives you the option to show or hide your guides. The guides will match the style of guides that have been set in the URSA Mini in the camera 'all' section of the 'monitor' menu.

The aspect ratio, frame guide opacity level, safe area percentage, and the type of grids shown will match what you have set in the camera. The 'setup' menu in the Studio Viewfinder then allows you to configure which type of guides you would like to see in the Studio Viewfinder when guides in the display menu are switched on. Guides then allows you to then switch these 'on' or 'off' with one command.

### **Zoom**

Turns the 'zoom' feature on and off. The 'zoom' feature helps you find sharp focus by zooming into your picture. When zoomed in, you can navigate to specific parts of the screen by rotating the menu dial left and right. The overlay will indicate which part of the picture you are zoomed into.

### **Display LUT**

When sending a 'film' dynamic range SDI signal from your URSA Mini, the 'film to video' and 'film to extended video' settings allows you to apply a more colorful and contrasty LUT to the image. The viewfinder will detect when either of these LUTs are used and will give you the option to toggle them on or off in your viewfinder. When a display LUT is active on the front SDI output, or you are using a different LUT, the option is disabled to prevent multiple LUTs being applied.

### **Audio Meters**

The audio meters display the audio level that is being input via SDI into the Blackmagic URSA Studio Viewfinder, therefore the meters will show you URSA Mini's audio input levels. If you have program input selected, the audio meter will display these audio levels.

### **Exposure Meters**

Switches the display of the histogram 'on' or 'off'.

### **Red Channel**

Allows you to switch on or off the red channel of your image.

### **Green Channel**

Allows you to switch on or off the green channel of your image.

### **Blue Channel**

Allows you to switch on or off the blue channel of your image.

### **Black and White**

Switches between color and monochrome.

## **Shortcuts**

The shortcut function allows you to map specific functions to the F1, F2 and F3 buttons. These shortcut buttons allow you to quickly toggle 'on' and 'off' any of the settings in the display menu, or your cursors. This is extremely useful when you need to quickly access a particular setting for a frequently used feature.

To customize your shortcut buttons: In the 'shortcuts' menu, rotate the push button 'menu' dial to move up or down and select one of the 3 buttons. Press the 'menu' dial to confirm your selection and then rotate the 'menu' dial to scroll through the assignable features. You will have the option to select one of the following features: 'zoom', 'cursor 1', 'cursor 2', 'cursor 3', 'zebra', 'false color', 'guides', 'film to video', 'audio meters', 'exposure meters', 'red channel', 'green channel', 'blue channel', 'black and white'. Once chosen click the menu button to confirm that selection, and assign that function to the chosen shortcut button. Pressing the shortcut button will now switch this feature 'on' and 'off'.

Once you have set up your shortcuts as required you can either scroll to 'exit' and press the 'menu' dial to close the menu display view, or hit the back button to exit out of the menu.

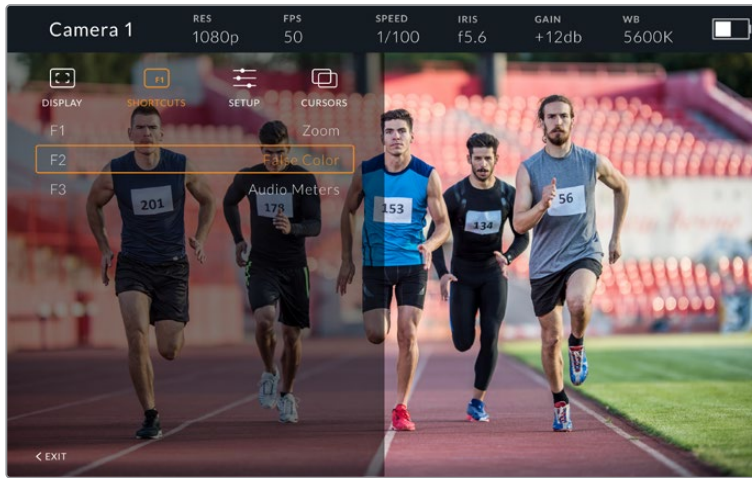

The 'shortcuts' submenu

## Setup

The 'setup' menu is where you choose your preferences for how the viewfinder is setup.

### Front Tally Brightness

Allows adjustments of tally LED brightness between 'off', 'low', 'medium' and 'high'. The tally light will illuminate whilst adjustments are being made so you can see what each brightness level represents.

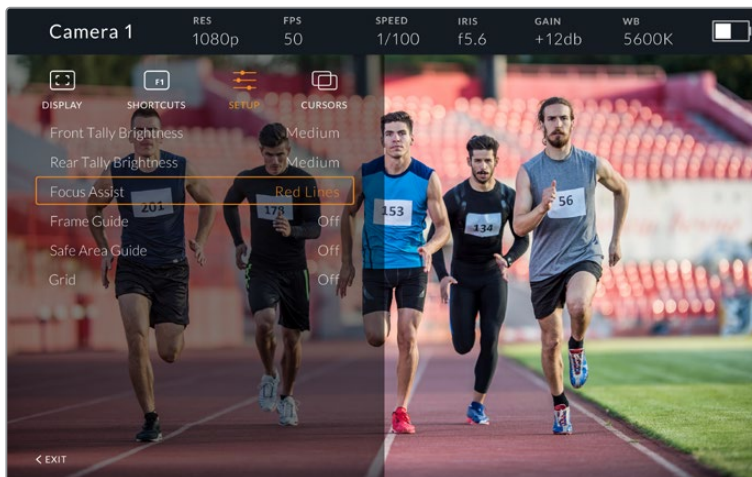

The 'setup' submenu

### Rear Tally Brightness

Allows adjustments of tally LED brightness between 'low', 'medium' and 'high'. The tally light will illuminate whilst adjustments are being made so you can see what each brightness level represents.

**TIP** A high LED brightness setting is recommended for bright conditions, as it will provide greater visibility for talent and operators in the conditions. A low LED brightness is recommended when filming in darker environments where it is easier to see when the light is on.

## Focus Assist

The 'focus assist' setting toggles the appearance of peaking on the viewfinder. You have the choice of 'red', 'green', 'blue', 'black' and 'white' as well as traditional peaking.

## Frame Guide

Gives you the option to show 'frame guides' as part of your Studio Viewfinder's 'Guides'. When connected to URSA Mini they will match your camera's 'frame guides' aspect ratio. When connected to other systems they will default to the 14:9 aspect ratio.

## Safe Area Guide

Gives you the option to show the 'safe area' indicator as part of your Studio Viewfinder's 'Guides'. When connected to URSA Mini these will match your camera's 'safe area guide' percentage. When connected to other systems they will default to 90%.

## Grid

Gives you the option to show grids as part of your Studio Viewfinder's 'Guides'. When connected to URSA Mini these will match your camera's 'grids' settings. When not connected, this will switch your crosshairs on or off.

## Cursors

The cursors allow you to mark an area on screen where graphics like a lower third, graphic, logo or ticker will be overlaid. To adjust these cursors go to 'cursors' and select 'edit cursors'. This will bring up a page that shows you all three cursors and allows you to select each one individually and then dial in the width, height, x and y co-ordinates for positioning each one individually.

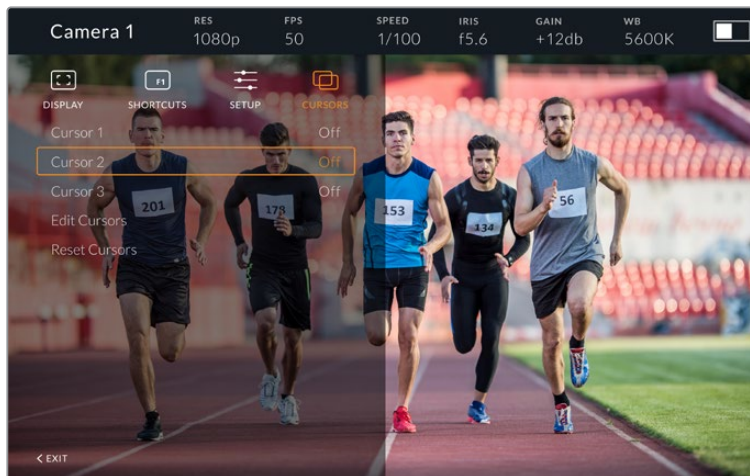

The cursors submenu

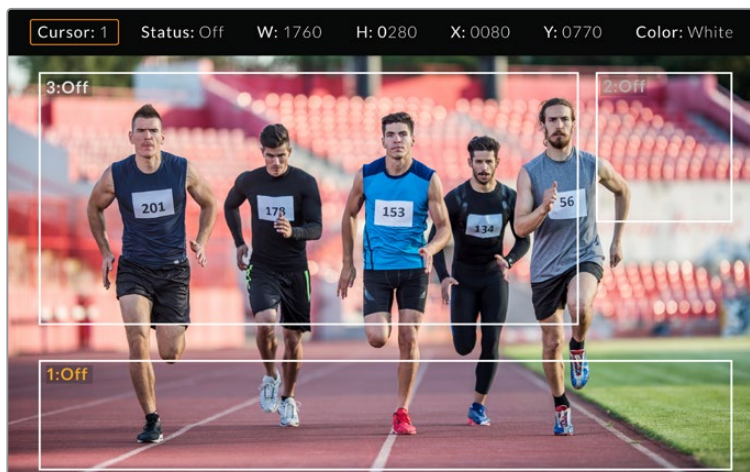

Cursors displayed on screen

Once you have set them up they can be switched on or off from the 'cursors' menu or assigned to your function keys for quick access. This is important for live production, as it allows the camera operator to take this into consideration and accurately compose and frame shots. You can create up to three black or white custom cursors that can have variable height, width and position, making it easy to match the size and location for all the graphics that will be added live or during later broadcast. You also have the option to reset the cursors to their default state.

### Using a headset with the Blackmagic URSA Studio Viewfinder

When using the Blackmagic URSA Studio Viewfinder with URSA Mini, the headphone connection on the camera will now become a talkback headset connection, allowing for direct communication with the director.

For more advanced talkback functionality, you can also use Blackmagic Camera Fiber Converter and Blackmagic Studio Converter to allow you to use standard broadcast headsets with 5 pin XLR connectors. For more information, refer to the 'Blackmagic Fiber Converters' section.

**TIP** Because URSA Mini's headphone socket is iPhone headset compatible, you can use your iPhone headset to communicate with the director. Pushing the button on the built-in remote will allow you to talk back to the director.

### Updating URSA Viewfinder's Internal Software

Update your viewfinder using the Blackmagic Camera Setup utility software. The viewfinder will need to be powered when updating, so we recommend keeping the viewfinder connected to your URSA during the update process. This also means your URSA will need to supply consistent power, so be sure to plug into external power.

Remove the sun hood to provide access to the small USB-C connection located on the bottom of the Blackmagic URSA Studio Viewfinder, and connect your computer to the USB-C port. When Blackmagic Camera Utility is launched and your viewfinder is connected to your computer, you will be prompted to update if your computer detects that your viewfinder is using an older version. Follow the on screen prompts to update your viewfinder's internal software. Refer to the 'Blackmagic Camera Setup Utility' section in this manual for more information.

We recommend updating all your Blackmagic URSA equipment at the same time for optimized performance.

**NOTE** When using your Blackmagic URSA Studio Viewfinder with URSA Mini, we recommend updating your viewfinder's internal software to the latest version to ensure compatibility. The latest software can be found at the Blackmagic Design support center at [www.blackmagicdesign.com/support](http://www.blackmagicdesign.com/support). Refer to the 'Blackmagic Camera Setup Utility' section in this manual for more information.



## Mounting Batteries

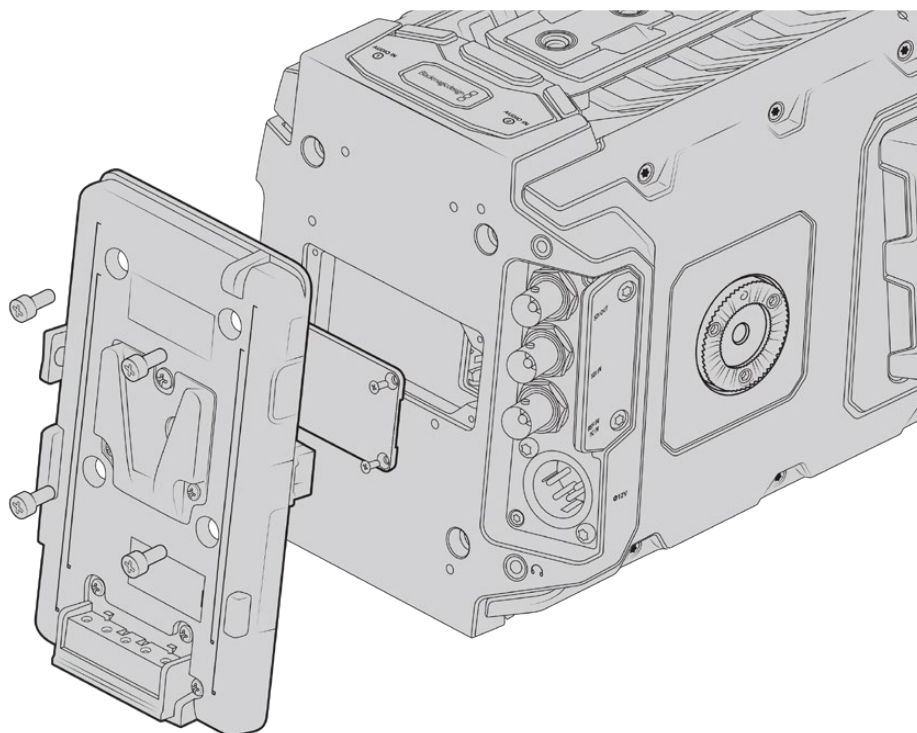

Connecting a third party battery plate lets you mount V-mount or gold mount batteries

### Mounting V-mount or Gold Mount Batteries

You can easily mount industry standard V-mount or gold mount batteries to Blackmagic URSA Mini.

To mount a battery, you'll need to attach a Blackmagic URSA VLock Battery Plate or URSA Gold Battery Plate, or else attach a third party battery plate to your camera's plate mount.

**TIP** Blackmagic URSA VLock Battery Plate and URSA Gold Battery Plate support displaying percentage information with compatible batteries. Blackmagic battery plates have a '+12V out' connector referred to as a 'D-tap' or 'P-tap' to power accessories such as an external monitor. It is worth noting that because this output is regulated from the camera, it will power down safely when the camera switches off. This regulated output supplies 12 Volts at up to 1.5 Amps. Some third party URSA battery plates, and even some batteries, offer an unregulated D-tap output. These supply continuous power when the camera is rebooting or power cycled, but the voltage varies depending on the charge level of the battery and accessories plugged in will drain the battery continuously.

You can purchase Blackmagic URSA VLock Battery Plates and URSA Gold Battery Plates from Blackmagic Design resellers, or third party battery plates from suppliers of professional digital cinema and video equipment.

If you don't have an off the shelf battery plate designed for Blackmagic URSA or URSA Mini and you want to modify your own battery plate, then you can use the supplied adapter cable and connector. Refer to the 'using your own battery plate' section for information about how any battery plate can be modified to use with URSA or URSA Mini.

#### To mount your battery plate to the rear panel:

- 1 If your URSA Mini has a molex power cover attached to the rear panel, remove it by unscrewing the 4 corner screws with a phillips head PH1 screwdriver.
- 2 Connect your battery plate's molex connector to your camera's molex power connector.
- 3 Screw the battery plate onto your Blackmagic URSA Mini's plate mounting points using 4 x M3 screws. Make sure the connector cable is tucked safely into the cable slot and not crushed between the plates when tightening.
- 4 With the battery plate connected to your camera, you can now mount a V-mount or gold mount battery and power up your camera.

## Using your own Battery Plate

### Adapter Cable and Connector

If you don't have an off the shelf battery plate designed to plug into URSA Mini and want to modify your own battery plate, you can use the supplied adapter cable and connector, which is also available at your local Blackmagic Design support office.

To wire the adapter cable and connector to your battery plate:

- 1 Strip approximately half an inch of insulation from the end of each red and black wire.
- 2 Solder all 4 x red 'Batt' wires to the corresponding 'positive' wire from your battery plate.
- 3 Solder all 4 x black 'GND' wires to the corresponding 'negative' wire from your battery plate.

Ensure the joins are well insulated.

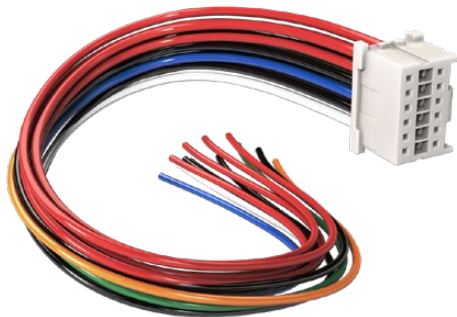

If you need to modify any battery plate to plug into URSA, use the supplied adapter cable and connector, which is also available from your local Blackmagic Design support office

This enables battery power to your camera. You can also connect additional wires for features such as 12 V output and battery status. Refer to your battery plate information, plus the diagram and tables on this page for help connecting the wires. If you require further assistance visit the Blackmagic Design support center at [www.blackmagicdesign.com/support](http://www.blackmagicdesign.com/support).

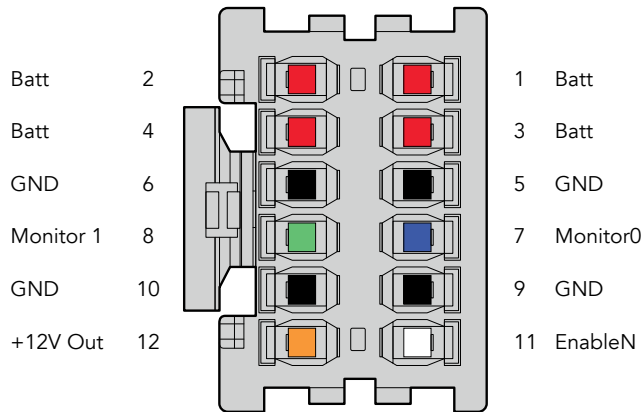

The rear view of the adapter's connector housing.  
Refer to the wire configuration table for a description of each pin

### Wire Configuration Table

Pins	Signal	Color	Direction	Description
1, 2, 3, 4	Batt	Red	To URSA	12 V to 20 V
5, 6, 9, 10	GND	Black	–	–
7	Monitor0	Blue	To URSA	Analog battery level or open drain data line (20 V max)
8	Monitor1	Green	To URSA	Open drain clock line (3.4 V max)
12	+12 V out	Orange	From URSA	12 V regulated output 1.5 A max (18 W)
11	EnableN	White	To URSA	Connect to GND to enable +12 V out. Leave floating if +12 V out is not required.

Each Batt and GND pin supports 3 amps. Make sure all Batt and GND pins are connected. To monitor the battery status using Anton Bauer, IDX, or Blueshape plates, follow the connection table below:

<b>Anton Bauer</b>	Connect the blue/white striped wire to the housing blue wire at pin 7.
<b>IDX</b>	Connect the green wire to the housing green wire at pin 8, and the gray wire to the housing blue wire at pin 7.
<b>Blueshape</b>	Connect the blue wire labelled 'SMBC' to the housing green wire at pin 8. Connect the brown wire labelled 'SMBD' to the housing blue wire at pin 7.

Secure any unused wires by cutting them as close as possible to the rear of the adapter connector.



# Blackmagic Fiber Converters

Blackmagic Camera Fiber Converter and Blackmagic Studio Fiber Converter are optional accessories that provide a SMPTE fiber connection between your camera and an ATEM switcher.

SMPTE fiber lets you connect all video, power, talkback, tally and camera control signals between an ATEM switcher and your camera using one single industry standard SMPTE hybrid fiber optic cable. Using a SMPTE fiber connection greatly reduces the amount of cables required, which helps makes the production setup more efficient and simpler to run. The standard connectors on Blackmagic Studio Fiber Converter allow you to easily add the fiber converters into an existing broadcast truck infrastructure.



## Blackmagic Camera Fiber Converter

Mounts to the back of your URSA Mini or URSA Broadcast and connects to the Blackmagic Studio Fiber Converter via a standard SMPTE hybrid 304 connector.

## Blackmagic Studio Fiber Converter

This converter converts the optical fiber SDI signal from the camera unit to SDI via BNC, which is then connected to an ATEM switcher. The converter also takes all return feed sources, including program return from the ATEM switcher, and sends them back to the camera unit.

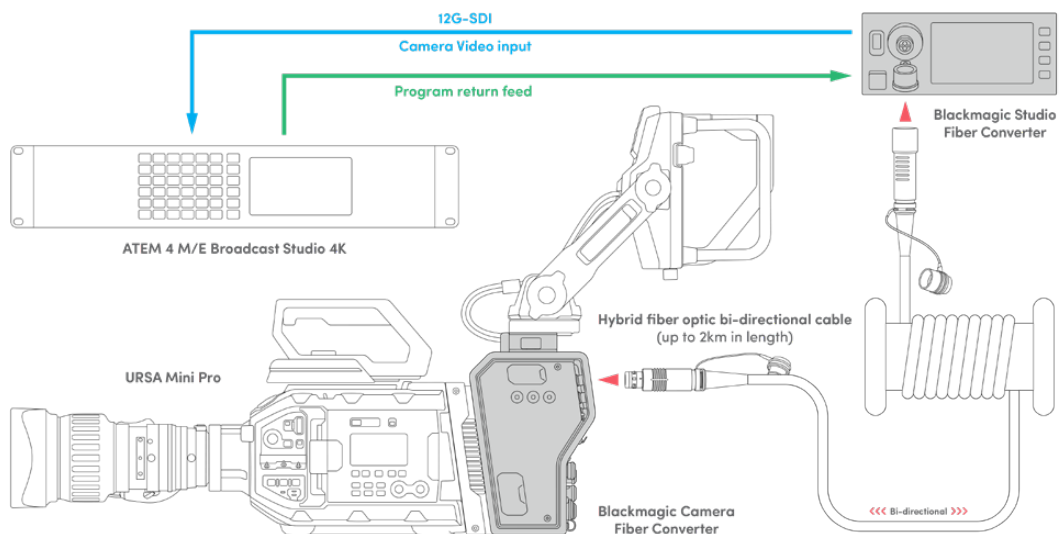

The Blackmagic camera and studio fiber converters connect via optical fiber to provide efficient SDI video, power, talkback, tally and control signals via a single SMPTE fiber optic cable.

# Getting Started with Blackmagic Fiber Converters

Getting started is fast and efficient. It won't take long before you are producing video content and enjoying the benefits of SMPTE fiber.

## About SMPTE Fiber

SMPTE fiber cables provide you with a simplified way to carry multiple signals as well as power, over long distances. This is useful in broadcast scenarios, as you don't need to connect several cables for each camera that is connected to your switcher.

With a SMPTE 311 hybrid fiber optic cable, you can use one single industry standard optical fiber cable to connect each camera to your ATEM switcher, and provide all video, power, talkback, tally and control signals along one cable. With optical fiber you can also carry these signals and power over longer distances up to 2 kilometers.

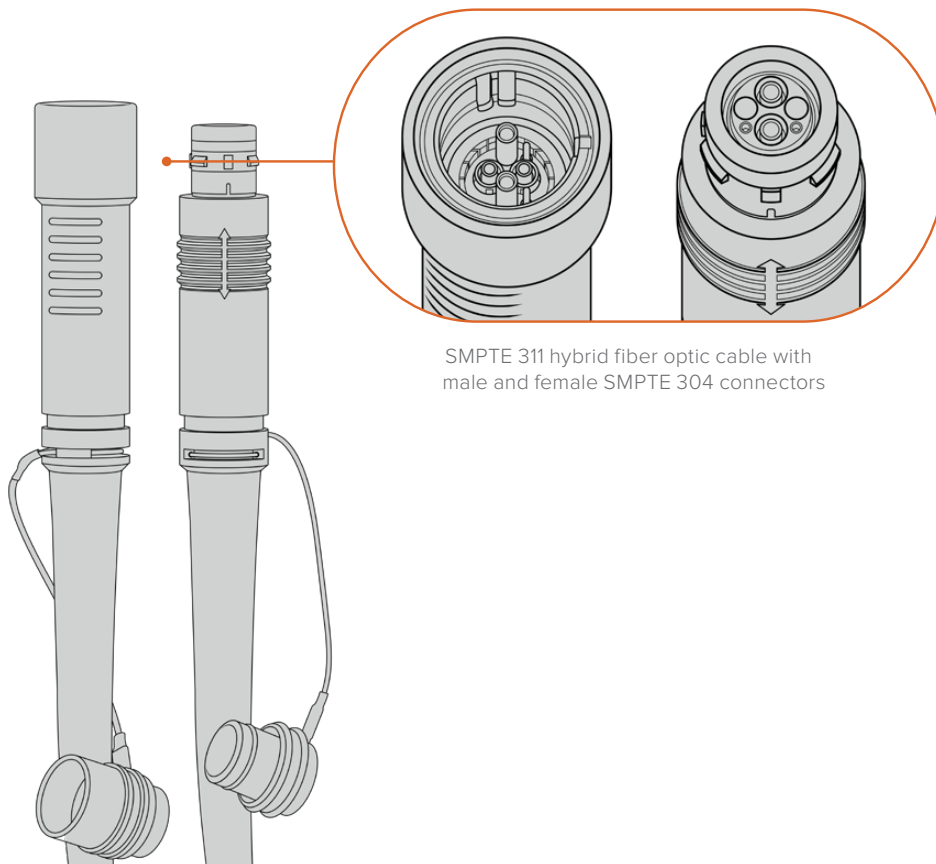

SMPTE 311 hybrid fiber optic cable with male and female SMPTE 304 connectors

**NOTE** The male and female ends of a SMPTE 311 hybrid fiber optic cable can be identified by looking for the male and female pins inside the tip of the SMPTE 304 connector. The gender of the connectors is not determined by their outward appearance.

**TIP** Connect the rubber cap from each end of the SMPTE fiber cable into the rubber cap on each converter to prevent any dust or debris from entering the caps.

One of the main benefits of using a SMPTE fiber connection is to connect to the control room or broadcast truck in a traditional live broadcast environment. Most modern sporting stadiums already have optic fiber cables installed between camera positions and the control room or broadcast truck, so this means you can plug directly into these systems.

The optic fiber cable used to connect to an existing fiber system, or to connect the two Blackmagic fiber converters together, is a SMPTE 311 hybrid fiber optic cable with SMPTE 304 connectors.

### Protecting SMPTE Connectors

It is very important that the SMPTE fiber cable's connectors are always protected by their rubber caps. This is because minute dust particles can collect very quickly on the polished ends of the glass fiber tubes which can interrupt signal flow. The best practice is to immediately replace the rubber cap as soon as a connector is exposed. For example, immediately prior to connection, and immediately after disconnection.

It's also a good idea to connect the rubber cap from each end of the SMPTE fiber cable into the rubber cap on the converters whilst in use, to prevent any dust or debris from entering the caps.

### Plugging in Power

Power from the studio unit is sent through the fiber cable to the camera unit, therefore the first step to connecting power is to power the studio unit.

### Powering the Studio Fiber Converter

Plug a standard IEC power cable into the power connector on the studio unit's rear panel.

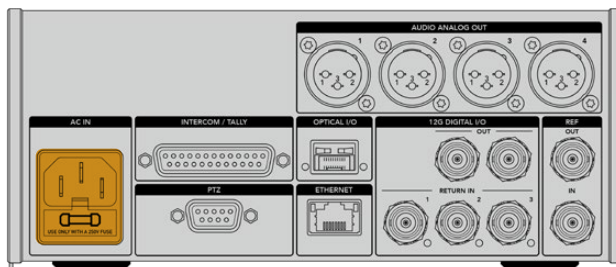

Connect power to your studio fiber converter via a standard IEC power cable

To turn the unit on, set the power switch on the front control panel to the 'on' position.

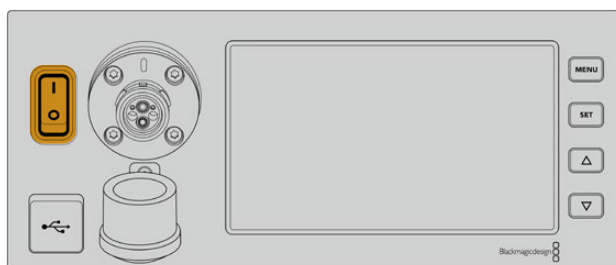

## Connecting SMPTE Fiber

The next step in getting started is to connect the SMPTE fiber cable between the studio fiber unit and the camera unit. This provides power from the studio unit to the camera unit, and fiber for all video feeds.

**NOTE** Extensive safety checks are initiated whenever a powered hybrid fiber optic cable is plugged into the converter and the power safety of the unit is continually monitored during use.

### Connecting the Fiber Cable to the Studio Unit

The male end of the SMPTE fiber cable's locks securely onto the female fiber connector on the front panel of the Blackmagic Studio Fiber Converter. This is a secure lock ensuring that the cable is not accidentally disconnected during broadcast.

#### To connect the cable:

Align the red indicator on the cable connector with the red dot on the unit's fiber connector, and plug the connector in until it securely clicks into place.

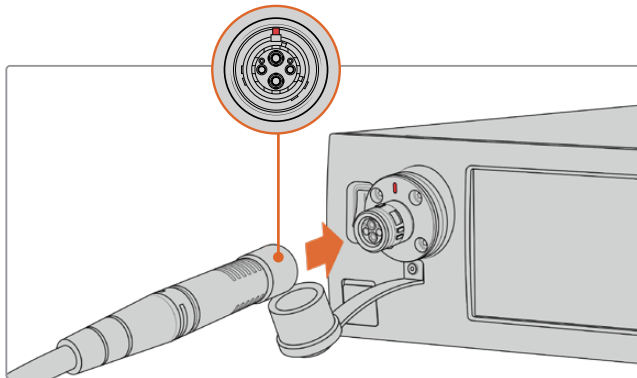

Plug the male end of the SMPTE fiber cable into the female connector on the front of Blackmagic Studio Fiber Converter

#### To disconnect the cable:

Push the metal base of the studio unit's fiber connector towards the front panel and remove the cable connector.

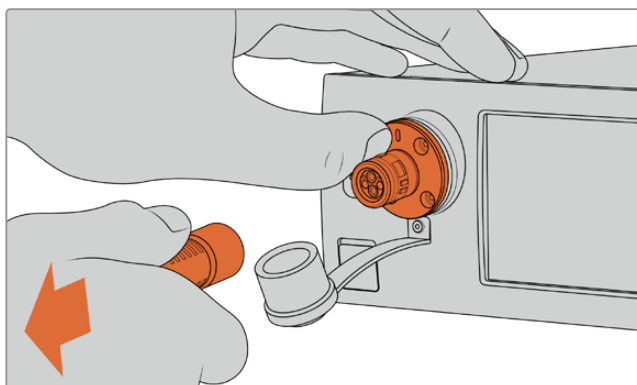

Push the metal base of the studio unit's fiber connector towards the front panel to disengage the cable connector allowing you to pull the cable away from the unit.

Once plugged in, it is a good idea to connect the rubber cap from the end of the SMPTE fiber cable into the rubber cap from the Blackmagic Studio Fiber Converter. This will prevent any dust or debris from entering the caps, and ensure that the caps remain clean.

## Connecting the Fiber Cable to the Camera Unit

The female end of the SMPTE fiber cable locks into the male connector on the side of Blackmagic Camera Fiber Converter, ensuring that the cable is not accidentally disconnected during broadcast.

### To connect the cable:

- 1 Align the red indicators on each connector, and plug the cable connector into the camera unit's connector until it securely clicks into place.
- 2 Once plugged in, it is a good idea to connect the rubber cap from the end of the SMPTE fiber cable into the rubber cap from the Blackmagic Camera Fiber Converter. This will prevent any dust or debris from entering the caps, and ensure that the caps remain clean.

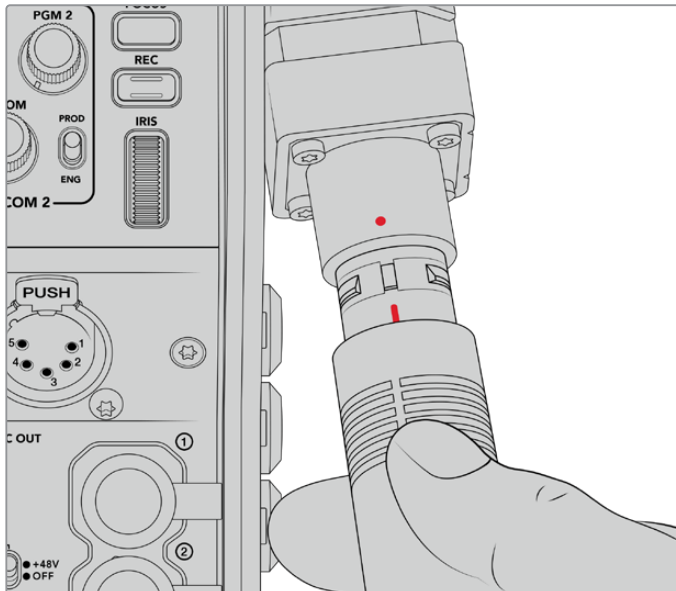

Align the red indicators to connect the SMPTE Hybrid Fiber Optic cable to the large connector on the Blackmagic Camera Fiber Converter

**NOTE** The SMPTE 304 connectors on the SMPTE 311 cable are very durable and lock firmly to the camera. If you need to disconnect the cable, please ensure that you have the camera firmly attached to a tripod head or are bracing the camera with your spare hand while trying to disconnect the cable.

### To disconnect the cable:

- 1 Pinch the top section of the female end of the cable, and compress the rubber sheath around the cable, pulling it gently away from the tip of the cable until you can see the red ring under the sheath. This will detach the teeth from the locking mechanism.
- 2 Put one hand on the camera to brace it gently, and pull the cable away from the connector on the Blackmagic Camera Fiber Converter. The cable should disconnect easily without the need for excessive force.

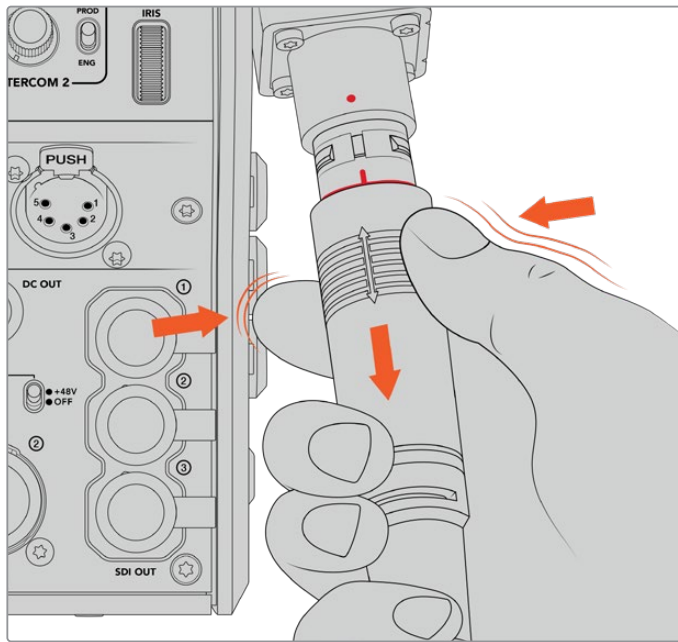

Pinch the rubber around the tip of the cable to reveal the red ring below, then pull the cable to disconnect

**NOTE** The SMPTE hybrid fiber cable is the heart of the broadcast ecosystem, so it is crucial that great care is taken. For example, avoid kinks in the cable, always prevent the cable from being pressed under heavy items, and avoid bending at 90 degree angles. Avoid dropping the connectors and take care when connecting and disconnecting. Always cap the connectors as soon as they are exposed.

## Confirming Power and Fiber

The two units will now establish a handshake process to determine that power is being supplied safely and fiber is securely connected.

**This process involves the following:**

- 1 The studio unit establishes a low power state with the camera unit. This is shown by the camera unit's red power status indicator.
- 2 Once power is determined as safely connected, a high power state is established and the camera unit's power indicator will illuminate green.
- 3 The fiber connection is confirmed and the fiber status indicator will illuminate green.

This is usually very fast and the indicators can turn green almost immediately. If you are using a cable over greater distances, the handshake process can take a moment longer before indicators illuminate green.

If the power light remains red for an extended period of time and does not turn green, or flickers between red and green, check that both ends of the fiber cable are securely connected. If the interruption persists, check the condition of your fiber cable.

## Power Safety Considerations

The SMPTE hybrid fiber optic cable is capable of carrying high voltage over long distances so that you can power a camera and accessories that are located up to 2km away.

To ensure safe operation, your Blackmagic Studio Fiber Converter has safety mechanisms built in to ensure accurate monitoring and automatic management of the voltage being carried.

A dedicated micro controller along with internal handshaking and communication between the Blackmagic fiber converters ensure that a hybrid fiber optic cable remains off until it is plugged into the Camera Fiber Converter. It then goes into a low power state and completes safety checks before going into high power mode. High voltages are not enabled until the converters ensure that an optical signal is present, there is a 5mA signal core current loop, and there is less than 30mA of imbalance between the power cores.

## Connecting to an ATEM Switcher

### How to connect Blackmagic Studio Fiber Converter to your switcher:

- 1 Connect a BNC cable from Blackmagic Studio Fiber Converter's rear 12G-SDI output to one of the SDI inputs on your switcher. Ensure your camera is set to use the same format and frame rate as your switcher.
- 2 Connect a BNC cable from your program return feed output on your switcher to the 'return in' 1 input on the studio unit's rear panel.

**TIP** When using multiple cameras in a live production, you may need to run the program return feed from the switcher through a Teranex Mini SDI Distribution 12G or a Smart Videohub. That is because there are a set number of program outputs on the switcher and you will likely need access to more.

- 3 If you require any other return feeds to be sent to your camera such as a clean program return feed, a teleprompter feed, an ISO feed from another camera, graphics or any other signal then plug these into 'return in' 2 or 3.

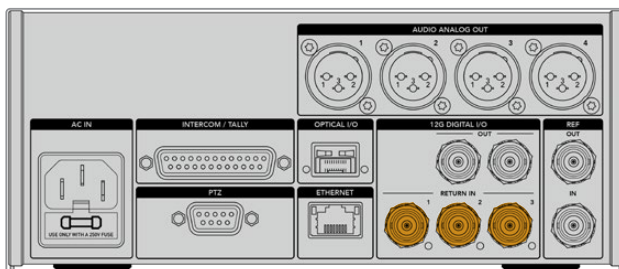

Plug the program return feed from the switcher and other return sources into the 'return' inputs on the studio unit's rear panel

## Confirming Video

You can now check that video is working and all return feeds are present.

- 1 Ensure the ATEM switcher's program output is connected to the studio unit's SDI return input 1.
- 2 If you want to check all return feeds, plug video sources into SDI return inputs 2 and 3.
- 3 Now plug an SDI monitor, such as a Blackmagic SmartView 4K, into the 'SDI out' on the side panel of the camera unit.

With a monitor connected to the SDI output, rotate the corresponding selection knob next to the return button to switch between all three return feeds. You can set the two return buttons to monitor two different return feeds if you want to.

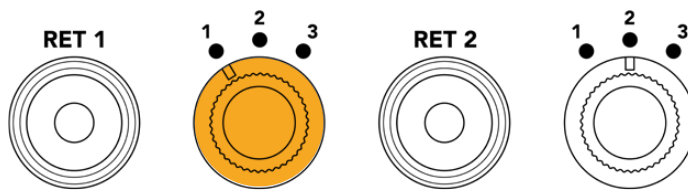

Switch between the return feeds on the camera unit and press the corresponding return button to view the selected feed on a monitor

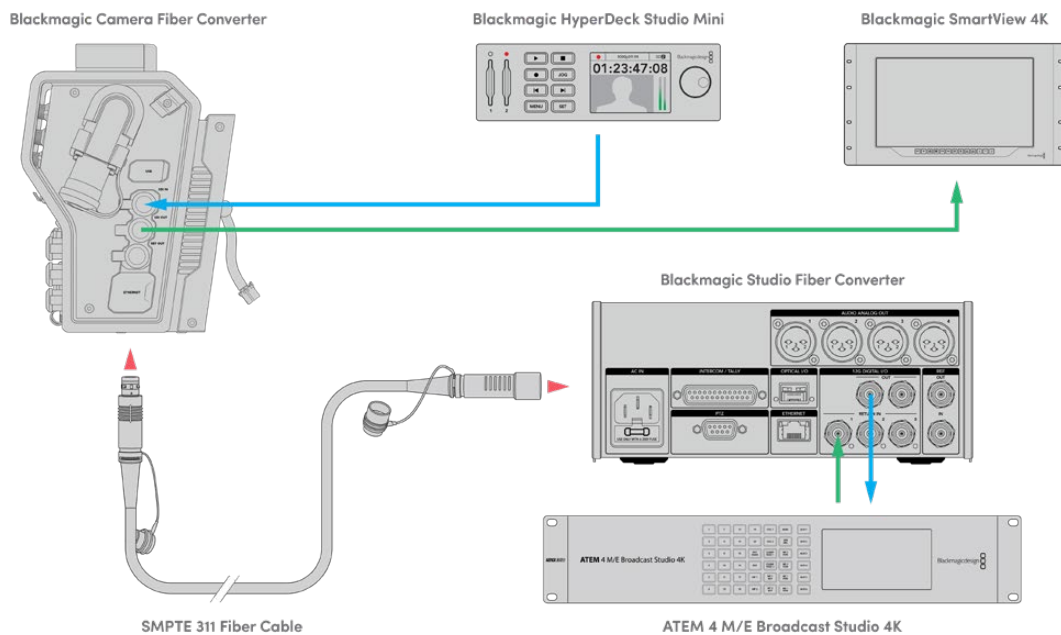

To confirm video, plug video sources into the return feed inputs on the studio unit, then view them on a monitor connected to the camera unit

## Why Connections on the Front?

The fiber connection is located on the front of the studio unit so it can become the optical patch connection in the rear of a rack. Typically, the studio converter will be installed facing the rear of a rack so the SMPTE cables can be plugged direct into the unit. This means there is no need for extra rack patch panels and the cost of an extra short cable to the fiber unit. The large LCD next to the SMPTE fiber connector lets you quickly verify a good connection to the camera.



## Plugging in Camera SDI

Connecting video signals between your Blackmagic Camera Fiber Converter and URSA Mini or URSA Broadcast, is as simple as connecting two of the three included SDI cables from the side of your converter to the rear of your camera.

### How to connect your Camera Fiber Converter to your camera

- 1 Connect one of the included BNC cables from Blackmagic URSA Mini or URSA Broadcast's rear 12G-SDI output to the SDI input on Blackmagic Camera Fiber Converter.
- 2 Connect one of the included BNC cables from the SDI output on Blackmagic Camera Fiber Converter to the 12G-SDI input on Blackmagic URSA Mini or URSA Broadcast's rear panel.

## Plugging in Return SDI Outputs

The three SDI outputs marked 'SDI Out' on the front of the camera unit are loop outputs of the return feeds coming from the switcher. These let you connect the return feeds to other SDI equipment near the camera, for example a teleprompter or talent monitor.

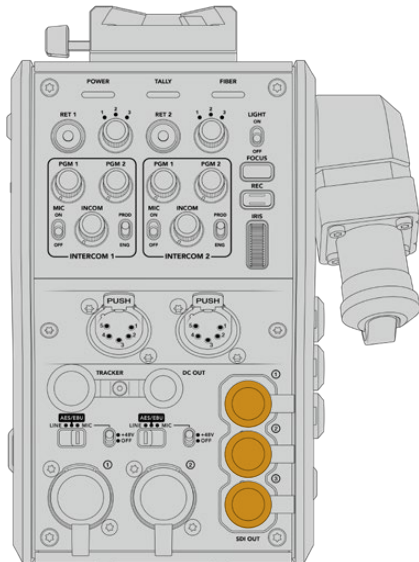

The three return feed loop outputs can be connected to SDI equipment near the camera, for example a teleprompter or monitor

**NOTE** The return feed SDI loop outputs support 3G-SDI to provide enough bandwidth for three separate feeds. This means Ultra HD return feeds from the switcher up to 2160p60 are down converted to 1080p at the equivalent frame rate.

## Mounting Blackmagic Camera Fiber Converter

Blackmagic Camera Fiber Converter mounts to the back of URSA Mini and URSA Broadcast directly behind the camera body, and connects to your camera's rear SDI in and SDI out BNC connectors. If you have installed a battery plate to the rear of your camera, you will need to remove it before connecting the Blackmagic Camera Fiber Converter.

**NOTE** Before installing Blackmagic Camera Fiber Converter you should check that URSA Mini's internal software is version 4.4 or above and URSA Broadcast is 4.6 or above. You can check your software version on page 4 of the camera's 'setup' menu. For more information on updating your camera firmware see the section 'Blackmagic Camera Setup Utility' in this manual.

When attaching Blackmagic Camera Fiber Converter, you will need the following tools:

- 1 x phillips head screwdriver
- 1 x 2.5mm Hex driver

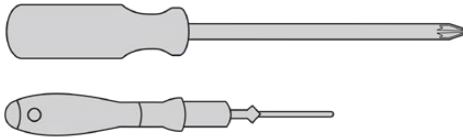

To attach the Blackmagic Camera Fiber Converter to your URSA Mini or URSA Broadcast, you will need a large phillips head screwdriver and a 2.5mm Hex driver

To mount and connect Blackmagic Camera Fiber Converter:

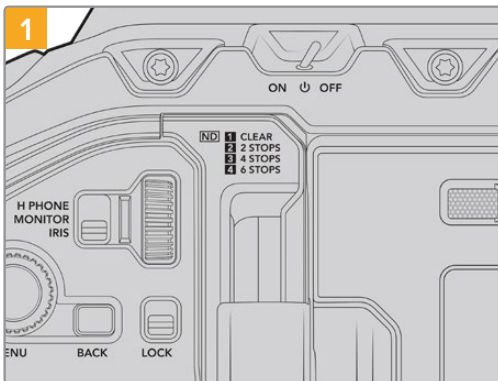

1 Ensure your camera is powered off. If using URSA Mini Pro or URSA Broadcast, power it off by moving the power switch to 'off'.

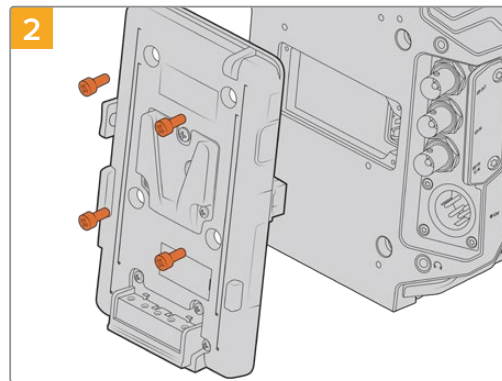

2 Remove the battery plate or mox power cover plate, if attached, using a phillips head screwdriver.

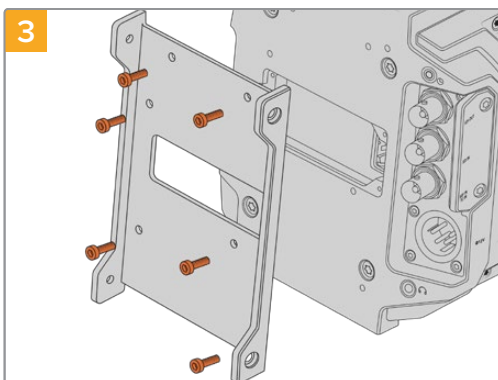

3 Attach Blackmagic Camera Fiber Converter's mounting bracket using 6 x 2.5mm Hex screws.

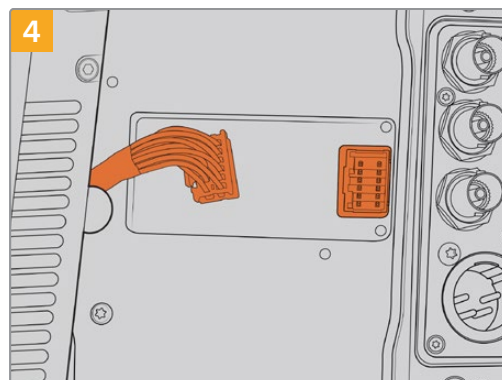

4 Plug the mox connector on Blackmagic Camera Fiber Converter into the mox power socket on your camera's rear panel.

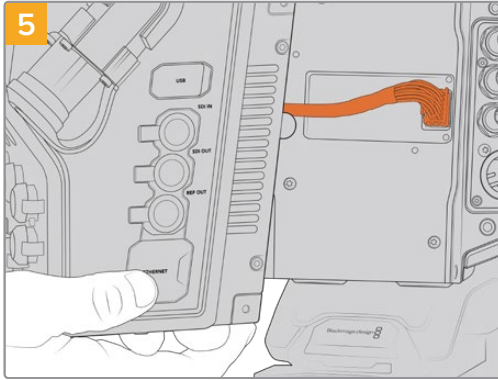

Slide the Blackmagic Camera Fiber Converter onto the mounting bracket, and attach it using 2 x 2.5mm Hex screws on each side of the bracket.

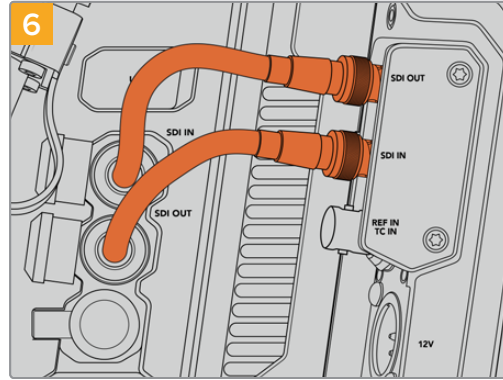

Use the included BNC cables to connect the SDI output on the back of your camera to the SDI input on Blackmagic Camera Fiber Converter, and the SDI output from the fiber converter to the SDI input on the rear of your camera.

**NOTE** When setting up your production and using URSA Mini or URSA Broadcast with the fiber unit attached, it's important to maintain some clearance underneath the fiber unit to allow adequate ventilation.

As your camera will often be used on a tripod, or shoulder mounted, clearance will already be provided. However, if you are operating the unit sitting flat on a surface it is a good idea to attach the URSA Mini shoulder mount pad, or third party baseplate or bridge plate as this will maintain the cooling fan's air flow in the underside of the Fiber Converter.

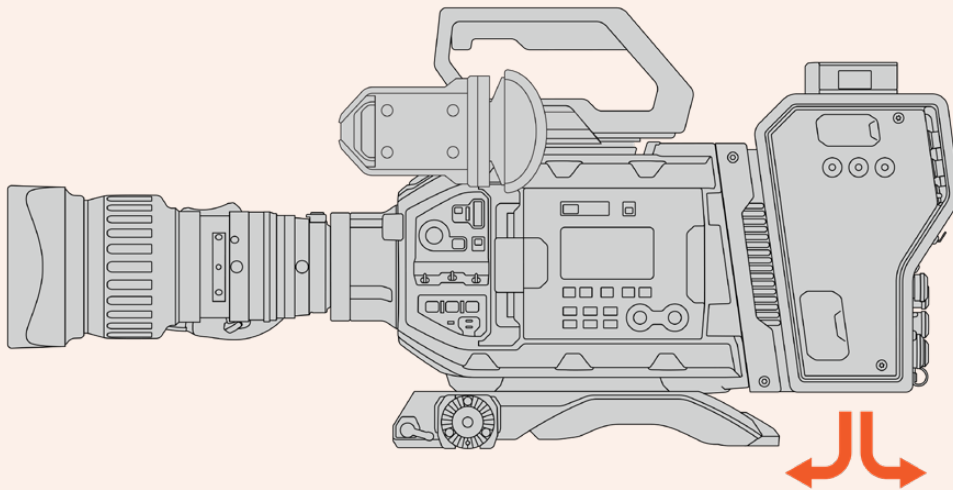

## Attaching the URSA Studio Viewfinder

The attached V-lock plate on the top of the unit lets you connect a Blackmagic Studio Viewfinder. This positions the studio viewfinder directly at the eye level when the camera is mounted on a pedestal or tripod.

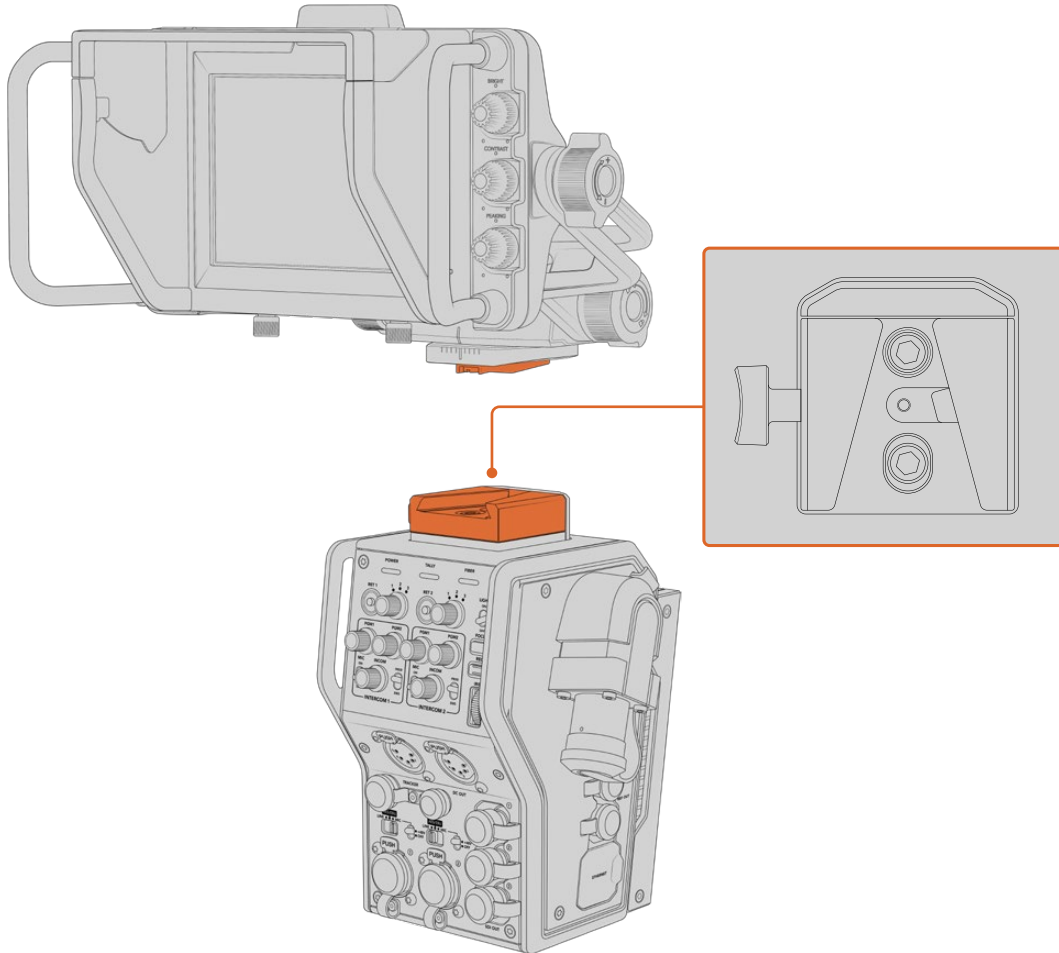

The V-Lock mount on the top of the camera unit lets you mount the Blackmagic URSA Studio Viewfinder

## Plugging in a Talkback Headset

Plug a broadcast headset into one of the two 5 pin XLR connectors on the front of the camera unit. Having two headset connectors allows two people to communicate with crew simultaneously.

That's all there is to getting started! With the fiber converters powered and video connected via SMPTE fiber, you can start using the converters to create your live production with greater flexibility and efficiency. Please continue reading the manual for more information on how to use all the features on your Blackmagic fiber converters.

# Operating the Camera Fiber Converter

## Selecting a Return Feed

The two return buttons on the front panel can be used in the same way as the PGM button on the camera, to switch the feed on the LCD, Blackmagic URSA Studio Viewfinder and HD monitoring outputs between the camera view and program return view.

The two return buttons marked 'ret 1' and 'ret 2' switch between two chosen return feeds. The three way rotary switches next to the 'ret 1' and 'ret 2' buttons assign which return feed you would like to view when you press the corresponding button to the left of the switch. These positions on the rotary switch relate to the 'return in' 1, 2 and 3 SDI connectors that are on the back of the Studio Fiber Converter.

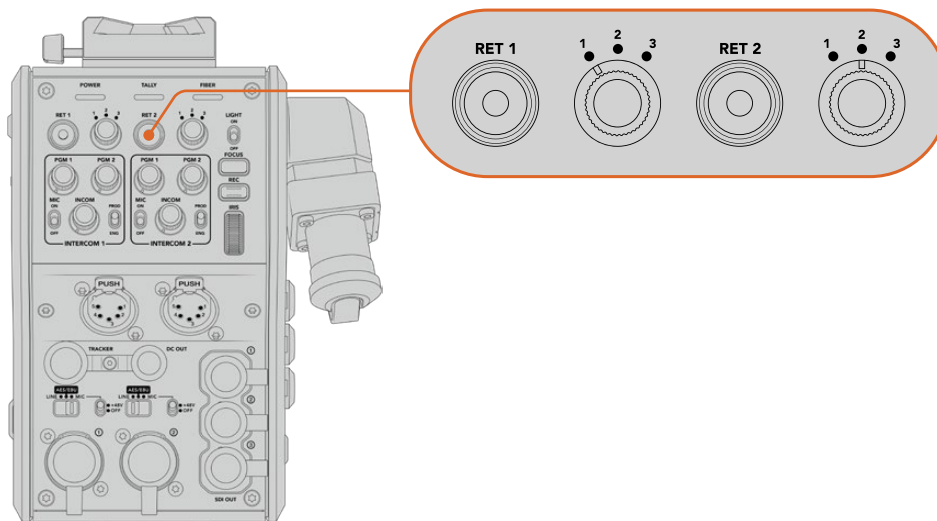

The return buttons and three way rotary switches allow you to select which return feed to view when the return buttons are pressed

Press and hold one of the return buttons to see the selected program feed. The program feed will continue to display whilst the return button is being held. Double press the return button to lock the display to the return feed. Pressing the return button again will exit the return feed and return to the camera view.

This means you can quickly and easily adjust which of the three return feeds being sent from Blackmagic Studio Fiber Converter you would like to have fast access to on the two return buttons. For example the three return feeds might be the switcher's program output feed complete with graphics, a teleprompter feed and a feed direct from another camera.

By using these switches you could assign 'ret 1' to be your program feed permanently and then use the second 'ret 2' button to check what is being sent to the teleprompter, and to occasionally switch it to check framing on another camera when you need to match its framing or angle.

There are also return buttons on the left side of the unit, marked 'ret 1' and 'ret 2' that provide additional access to view the return feeds when operating your camera from the side. They perform the same function as the return buttons on the front of the unit.

## Using the Call Button

Next to the return buttons is a 'call' button, that when pressed, flashes the red tally indicator on your Blackmagic Studio Fiber Converter's LCD screen. The 'call' button also makes a numbered 'press to talk' button on the panel of ATEM Talkback Converter 4K flash red. These visual indicators are to alert people in the control room that you need assistance.

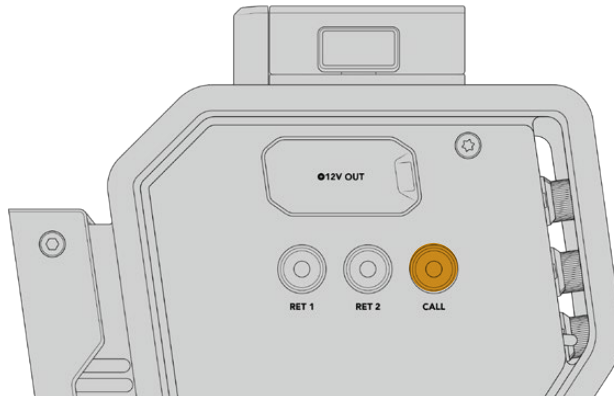

## Using Talkback

The two female 5 pin XLR connectors allow you to plug in two headsets, so that you and another crew member can have communication with the rest of the crew simultaneously.

The intercom controls for each headset are grouped into two sets for two independent intercoms, and are effectively three way audio mixers for each headset XLR connector that is directly below.

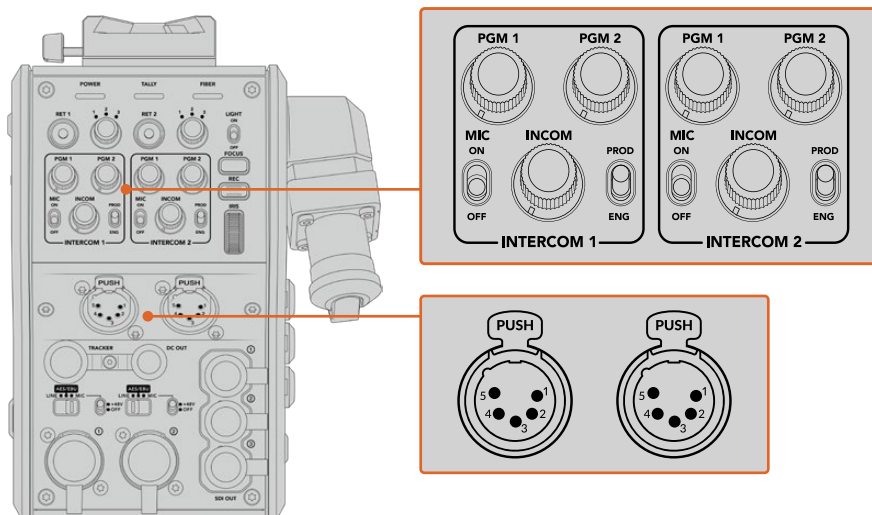

The intercom controls for each headset are located directly above each headset connection

You will hear the audio from the feeds that you have selected for 'ret 1' and 'ret 2' through a connected headset. The 'pgm 1' and 'pgm 2' dials adjust the audio levels of those feeds, and the 'incom' dial adjusts the overall volume. The 'mic' switch allows the operator to turn their headset microphone 'on' or 'off'.

Each intercom also has 2 selectable channels, a production channel and an engineering channel. This means that for broadcast setups with a large crew, you can split your crew communications between the two channels. The production channel lets you communicate with the director, producer and other crew members in the control room or broadcast truck, whilst the engineering channel lets you communicate with the lighting crew, technical operators and other camera operators. You can use the ‘talkback’ page in the menu of your Blackmagic Studio Fiber Converter to select the source for each channel as ‘SDI + DB25’ or ‘intercom tally DB25’ on your Studio Fiber Converter. For more information refer to the ‘operating the studio fiber converter’ section.

The Blackmagic Camera Fiber Converter also includes a standard 10 pin connection for tracker talkback, which is perfect when both headset connections are in use and you need to feed an additional talkback connection for your crane operator.

**TIP** Effective two-way communication between camera operators and the production and engineering crew is essential for busy broadcast and studio productions. Blackmagic Camera Fiber Converter has a ‘call’ button so camera operators can alert production and engineering crew and talk via their intercom headsets. Pressing this button flashes a numbered ‘press to talk’ button on ATEM Talkback Converter 4K, and makes the tally indicator on the LCD of Blackmagic Studio Fiber Converter flash. Likewise, if crew in a control room or broadcast truck have an urgent need to talk with a camera operator, they can press the ‘call’ button for that camera on the ATEM Camera Control panel. This makes the tally light on the Camera Fiber Converter flash and the tally light on the camera’s URSA Viewfinder or URSA Studio Viewfinder flash.

## Using Tally

The tally indicator on the front of the panel, provides a traditional tally indicator with red for program and green for preview, so that you know when the camera you are operating is on air.

## Status Indicators

The ‘power’, ‘tally’ and ‘fiber’ status LEDs at the top of the converter will illuminate different colors depending on the status of the unit. When the fiber cable is unplugged, no lights are illuminated.

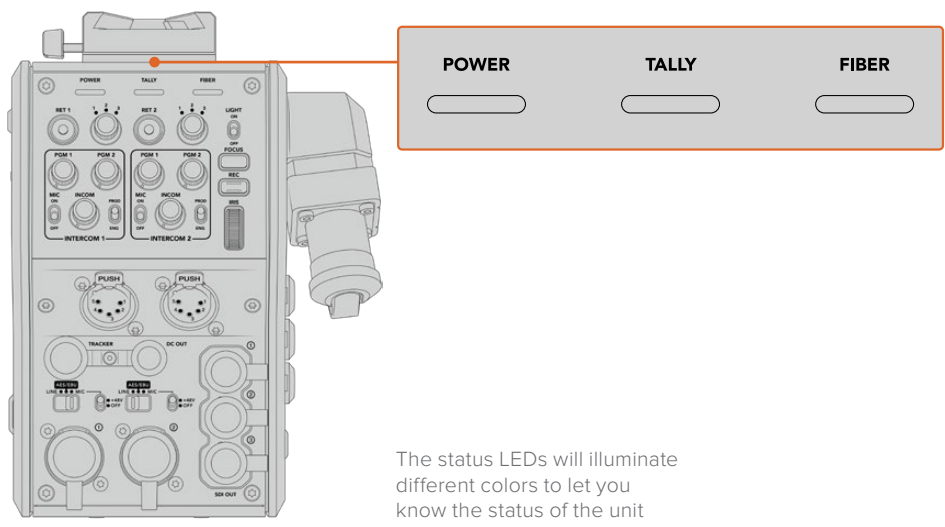



Below is a description of each LED color, LED action, and the status represented:

<b>Power</b>	<b>Constant Red</b>	When the SMPTE hybrid fiber optic cable is connected to a powered Blackmagic Studio Fiber Converter, and the other end of the cable is connected to Blackmagic Camera Fiber Converter, the power LED on the converter turns red to indicate that it is receiving power, and is in a low power state. In this low power state, intercom functionality is enabled but the full power required to operate the unit has not yet been enabled.  If the power LED remains red for an extended period of time and does not turn green, check that both ends of your SMPTE hybrid fiber optic cable are securely connected. If the connection remains unstable, check the condition of your fiber cable.
	<b>Constant Green</b>	After a successful fiber connection has been established and Blackmagic Studio Fiber Converter has determined that the cable connection is safe, the power LED will turn green and the camera converter will enter high power mode.
	<b>Flickering between Red and Green</b>	If the power LED flickers between red and green, check that both ends of your SMPTE hybrid fiber optic cable are securely connected. If the connection remains unstable, check the condition of your fiber cable.
<b>Tally</b>	<b>Constant Red</b>	The tally LED illuminates red to indicate that the camera you are operating is currently on air.
	<b>Constant Green</b>	The tally LED illuminates green to indicate that the camera you are operating is currently in preview mode.
<b>Fiber</b>	<b>Constant Red</b>	When the SMPTE hybrid fiber optic cable is plugged into the camera fiber converter, the fiber LED will turn red to indicate that the handshake process has begun, and the converter is in a low power state. In this state, intercom functionality is enabled for use while setting up or for troubleshooting the camera chain in case the fiber link is down.
	<b>Constant Green</b>	Once a successful SMPTE hybrid fiber optic cable connection is established, the fiber LED will turn green.

Once both the power and fiber lights are green, this indicates that the safety checks have been completed, and the converters have entered high power mode.

## Audio Inputs

Your Blackmagic Camera Fiber Converter has two XLR inputs labelled '1' and '2' that allow you to plug in external analog audio from professional equipment such as audio mixers, PA systems or external microphones.

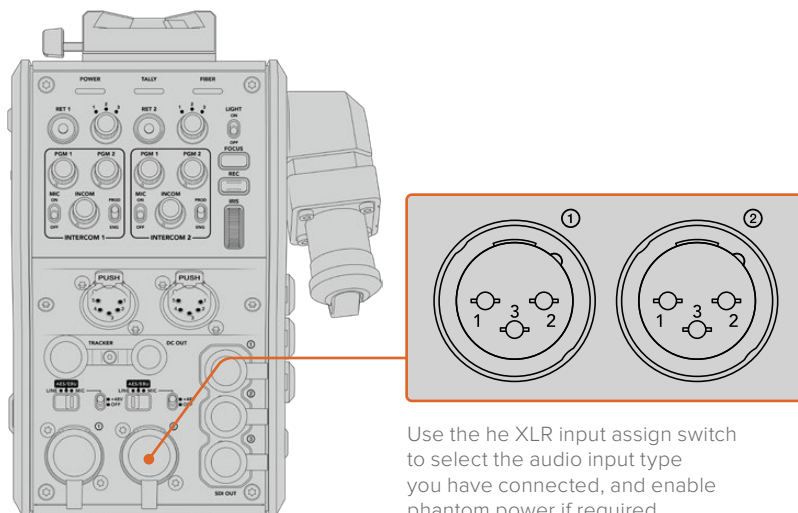



The camera audio is embedded into channels 1 and 2 of the camera feed, and the 2 audio inputs on the back of the camera fiber converter are embedded as channels 3 and 4. All 4 audio channels are also deembedded at the other end on the studio fiber converter as analog audio outputs.

The 'audio' page in the menu of your Blackmagic Studio Fiber Converter lets you adjust the input levels for audio sources connected to the XLR inputs on your Blackmagic Camera Fiber Converter. For more information refer to the 'operating the studio fiber converter' section. Once connected, you can use the XLR input assign switch to set how the XLR inputs behave when selected as an input source. The options available are mic audio, line level audio and AES digital audio.

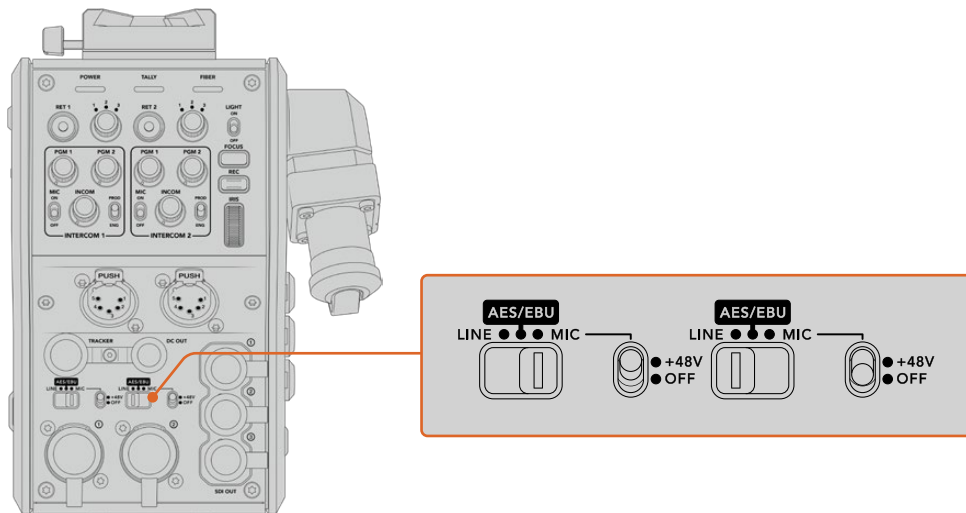

If you would like to connect microphones that aren't self powered, you can enable 48V phantom power. Move the phantom power switch to '+48V' to enable phantom power for any microphone connected to the XLR below, or 'off' to disable phantom power.

## IP Video

A connected SMPTE Fiber cable provides for a 10-Gbit IP link between your Camera Fiber Converter and the Studio Fiber Converter. This allows all of your video and return feeds to be IP video based using high end, visually lossless broadcast quality 10-bit video encoding and decoding. All other connections such as talkback, tally, camera control and lens control are also converted to low-latency IP so you get incredibly reliable performance.

## Power Specifications

The Blackmagic Studio Fiber Converter provides power for Blackmagic Camera Fiber Converter, your camera and it's accessories. A molex connector plugs into the molex socket on your camera's rear panel to send power to your camera from the Camera Fiber Converter.

If you need to position your camera at a distance of more than 2.1 km from the broadcast truck, and your camera and converter are not receiving enough power over the long cable run, you can power the camera and converter locally by having the 4 pin XLR from the camera's power supply plugged into the +12V input on your URSA Mini or URSA Broadcast. The power will be sent through the molex connector to the Camera Fiber Converter.

The '+12V out' connector, sometimes referred to as a 'D-tap' or 'P-tap' allows you to power accessories like an external monitor or a large box lens, with 12V DC nominal at up to 500 mA. The 'DC out' connector provides an additional option for powering accessories like an external monitor. A pinout table for the DC out connector is provided below.

## DC out connector Pinout Diagram

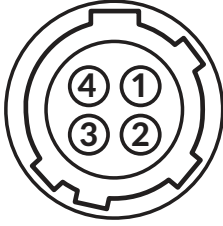
External view	Pins	Signal	I/O	Specifications
 <p>'DC out' connector</p>	1	Unregulated GND	–	GND for Unregulated Out
	2	NC	–	No connection
	3	NC	–	No connection
	4	Unregulated Out	Out	12V DC nominal at up to 500 mA.

## Additional Camera Controls

When URSA Mini or URSA Broadcast is being used as a studio camera, we have added camera controls on the fiber converter including iris and focus control, so you can control compatible lenses from behind the camera. This is helpful if you don't have a camera control operator controlling the lens remotely.

As a studio camera, URSA Mini and URSA Broadcast still have the ability to record internally, so the record button lets you trigger internal recording on the camera.

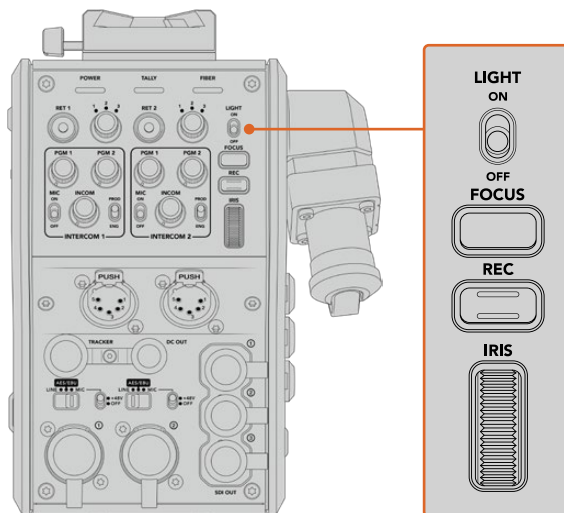

### Light

Turns on the backlight to illuminate the operation panel, so that all your controls can be seen easily when operating in a dark environment.

### Focus

Pressing the button marked 'focus' will trigger the autofocus if you are using a lens that supports autofocus.

### Record

Pressing the button marked 'rec' will trigger the recording when pressed, and will stop recording when pressed again.

### Iris

If you are using a compatible active lens that allows control from the camera, you can open or close the iris using the 'iris' wheel. Rotate the wheel up or down to open or close the lens aperture.

# Operating the Studio Fiber Converter

## Selecting the LCD Source

When powered on, your Blackmagic Studio Fiber Converter's large LCD will display the feed from your camera. As the central base unit, the Studio Fiber Converter takes the program feed from your switcher plus all return sources, and feeds them to the Blackmagic Camera Fiber Converter via the SMPTE fiber cable.

The built in LCD lets you monitor the camera feed and each source connected to the return feed inputs. It provides a heads-up type display with status information and audio meters.

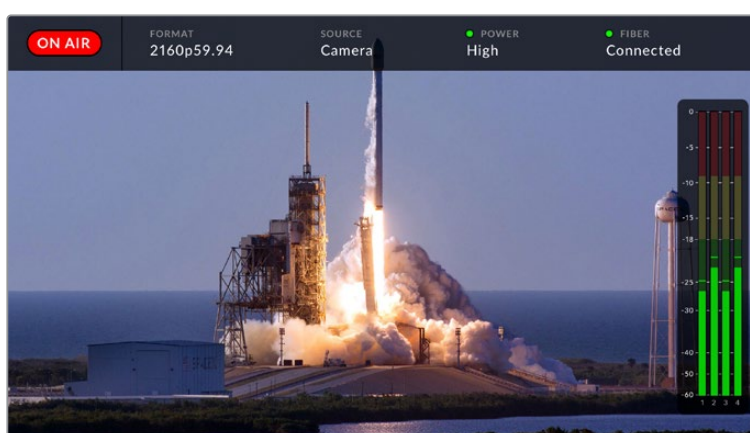

The overlays allow you to confirm the name and format of the source you are monitoring when switching between feeds

### **On Air**

The red 'on air' icon will be displayed when the connected camera is being used in the program feed, and will remain blank when not on air.

### **Format**

Displays the resolution and frame rate of the current source.

### **Source**

Displays the current source name.

### **Power**

Displays the current power status. 'Low' will be displayed with a red status light during connection to indicate a low power state and 'high' will be displayed with a green status light after the unit has entered high power mode. For more information, refer to the 'status indicators' section in the 'operating the camera fiber converter'.

### **Fiber**

Displays the current fiber status. 'Connecting' will be displayed with a red status light during the initial connection process and 'connected' will be displayed with a green status light once a successful SMPTE hybrid fiber optic cable connection is established. For more information, refer to the 'status indicators' section in the 'operating the camera fiber converter'.

### **Audio Meters**

The peak audio meters display audio levels when using camera audio embedded into channels 1 and 2 of the camera feed. Channels 3 and 4 correspond with audio sources connected to the two XLR inputs on the back of your Blackmagic Camera Fiber Converter. The display is calibrated to dBFS units and features peak hold indicators which stay visible for a short time so you can clearly see the maximum levels reached.

## Using the Menu

Pressing the up and down arrow buttons will scroll through the four possible sources 'camera', 'return 1', 'return 2' and 'return 3'. Press the 'menu' button to enter the menu system and adjust your settings. The arrow buttons can then be used to navigate through the various menu screens and the options within each screen, whilst the 'set' button will confirm your selection. The settings in the menu are divided between 'audio', 'talkback' and 'setup' pages.

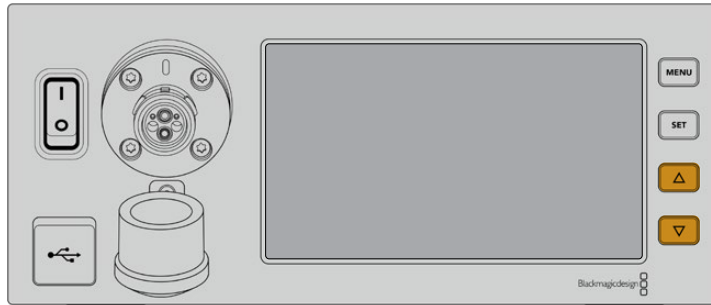

Press the up and down arrow buttons to scroll through the four possible sources and to navigate through the menu

### Audio

The 'audio' page lets you adjust the input levels for audio sources connected to the XLR inputs on your Blackmagic Camera Fiber Converter.

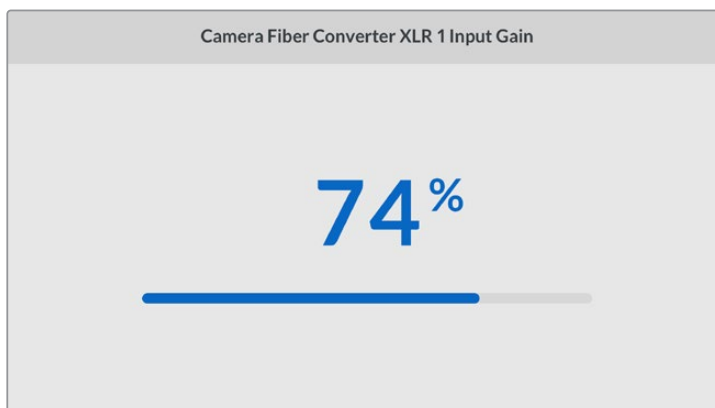
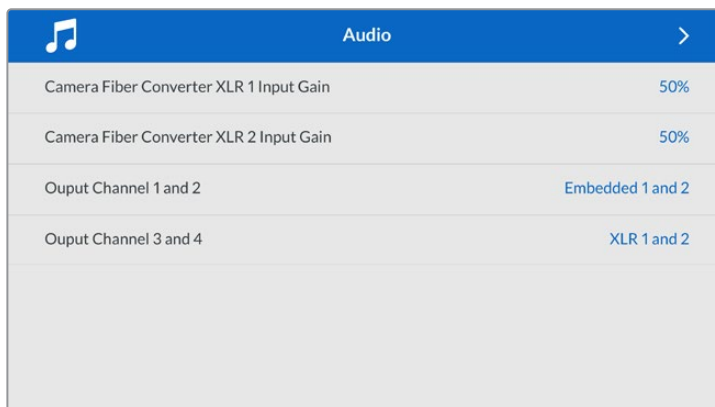

Use the arrow buttons to adjust the input level for each XLR input and the 'set' button to set the level

You can configure which audio channels from the Camera Fiber Converter get mapped to the embedded SDI and XLR outputs. The embedded audio channels from URSA Mini

or URSA Broadcast are on channels 1 and 2 by default. Line or Mic level XLR inputs that are plugged into the Camera Fiber Converter are mapped to channels 3 and 4 by default. You can adjust the output channel settings to change these mappings from their default settings. If either of the XLR inputs on the Camera Fiber Converter are set to AES, this expands your channel mapping options to include channel 5 and 6, which are sent on your embedded SDI output.

Output Channel 1 and 2	
Embedded 1 and 2	✓
XLR 1	
AES 3 and 4	

Mapping the embedded XLR channels from the camera to output channel 1 and 2

### Talkback

Use the 'talkback' menu to select your program audio source and talkback source for the production and engineering channel. Set the talkback source to 'SDI + DB25' or 'intercom tally DB25' on your Studio Fiber Converter.

You can also adjust the 'headphone gain' and 'headset microphone gain' for each intercom headset to account for the impedance levels of the headsets. The 'phantom power' settings let you switch on the phantom power being sent to the respective headset. Adjust the 'sidetone level' settings to let camera operators hear their own voice in their headset at a clear and comfortable level.

Talkback	
Program Audio Source	SDI Channels 1 and 2
Production Channel Source	SDI +DB25
Engineering Channel Source	Intercom Tally DB25
Intercom 1	
Headphone Gain	50%
Headset Microphone Gain	50%
Headset Microphone Phantom Power	On
Sidetone Level	50%
Intercom 2	
Headphone Gain	50%
Headset Microphone Gain	50%
Headset Microphone Phantom Power	On
Sidetone Level	50%

The intercom section will be greyed out when nothing is connected to the XLR inputs and will display 'connecting' during connection

## Setup

The 'setup' menu lets you configure the PTZ source, select the language for the menus, and select the type of SDI level return.

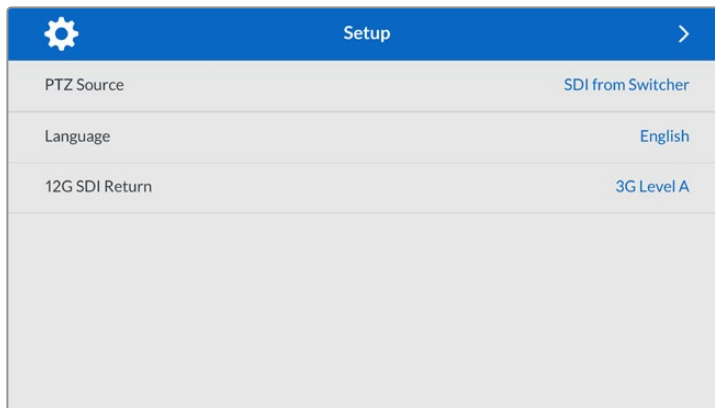

Select the source of PTZ commands using the PTZ source setting. You can select from 'SDI' or '9-pin', which correspond with the 'return in' SDI inputs and the 9-pin PTZ connector on the rear of your Blackmagic Studio Fiber Converter.

This means that you can control a PTZ camera's pan, tilt and zoom on an ATEM switcher and send these PTZ commands to your Blackmagic Studio Fiber Converter via SDI. These commands will be sent along the SMPTE fiber cable to your Blackmagic Camera Fiber Converter, where they will be de-embedded and output via the DE-9 serial connector, for connection to a PTZ motorized head.

You can also connect a PTZ controller to your Blackmagic Studio Fiber Converter via the DE-9 connector, to control a remote head at the camera end.

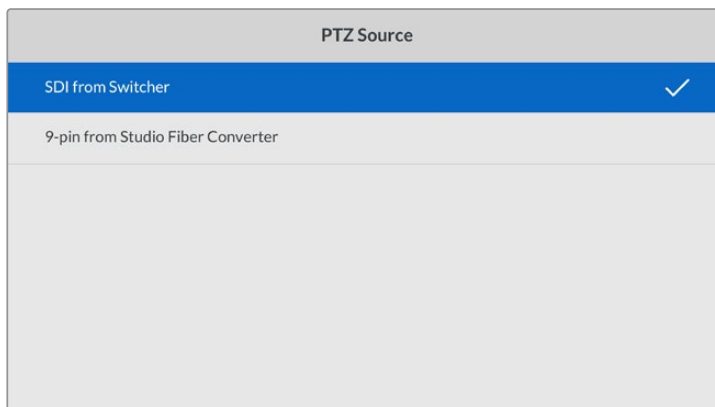

The settings menu page provides the option to select 'SDI' or '9-pin' as the source of PTZ commands

Language	
English	✓
中文	
日本語	
한국어	
Español	
Deutsch	
Français	
Россия	
Italiano	
Português	
Türkçe	

The 'language' setting sets the language for the menus. Studio Fiber Converter supports 11 popular languages: English, Chinese, Japanese, Korean, Spanish, German, French, Russian, Italian, Portuguese and Turkish. The language page will also appear on initial start up and after you update the internal software.

The '12G SDI return' option sets whether to down convert 12G program return signals to 3G Level A or 3G Level B. All 12G signals sent into return inputs on Studio Fiber Converter get down converted on their way to the Camera Fiber Converter.

## Rack Mounting the Studio Unit

If you're running multiple Blackmagic Studio Fiber Converters, you can use Blackmagic Studio Fiber Rack Kit to install your converters into a broadcast rack or road case. Using the rack kit, you can mount two studio units in a rack side by side, or fitted to either side. A blanking panel is supplied with the Studio Fiber Rack Kit to cover the empty side of the rack if you only want to mount a single unit.

Your Studio Fiber Converter is two rack units high, and is half the width of a standard rack shelf, so two Studio Fiber Converters can fit neatly side by side in a 2RU rack space.



Blackmagic Studio Fiber Converters mounted side by side



The supplied blanking plate can be used to cover an empty rack space if needed

**The Blackmagic Studio Fiber Rack Kit contains the following items:**

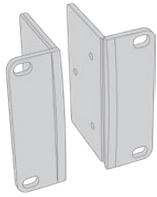

**2x Rack ears**

Attach rack 'ears' to the outside edge of Blackmagic Studio Fiber Converter for mounting in a rack

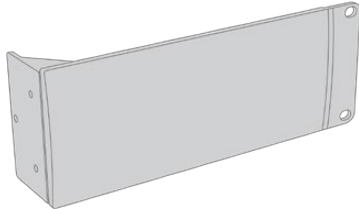

**1x Half rack width blanking panel**

The blanking panel has a mounting ear on one side so you can cover the empty rack space if you are installing a single unit. The illustration shows the ear on the right side. Simply rotate the panel 180° to mount it to the other side.

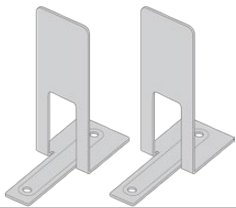

**2x Support brackets**

The T-shaped support brackets attach underneath the two Studio Fiber units where the two units meet at the front and the rear to provide support.

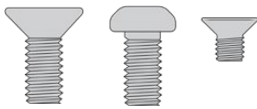

**Screws**

8 x M4 10mm	4 x M4 8mm	5 x M3 5mm
Rack ear screws	Blanking panel screws	Support bracket screws

**Preparing the Blackmagic Studio Fiber Converter for installation into a rack:**

- 1 Position the blanking panel on one of the sides of your Studio Fiber Converter, depending on whether you would like the unit to sit on the left or right side of the rack shelf. The front face of the blanking panel should be parallel with the front panel of the unit.
- 2 Attach the blanking panel to the side of your Studio Fiber Converter near the front using three of the supplied blanking panel screws.

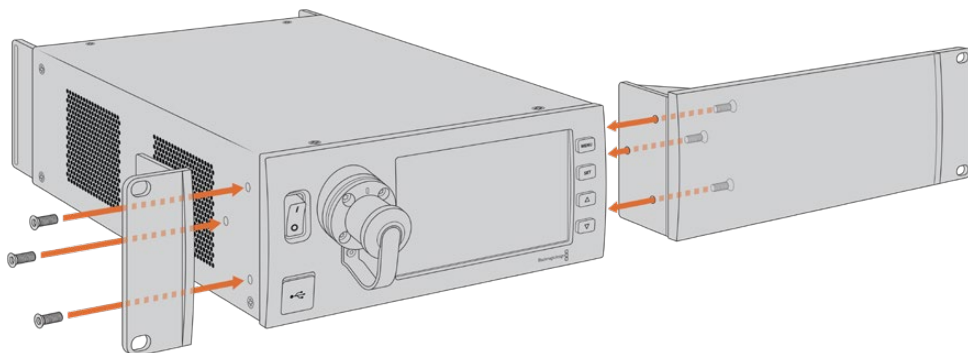

- 3 Use three of the supplied rack ear screws to attach a rack ear to the other side of your Studio Fiber Converter.

With the rack ear and blanking panel attached, you can now install your converter into a standard two rack unit space using the mounting holes on both sides and standard rack screws.



**Preparing two Blackmagic Studio Fiber Converters for side by side installation into a rack:**

If you are mounting two converters side by side, you can attach them to each other using support brackets which secures them together so you can mount them more easily.

To secure the two units:

- 1 Turn the two converters over so that they are upside down and placed side by side. Remove two rubber feet from the edges of each converter where they meet.

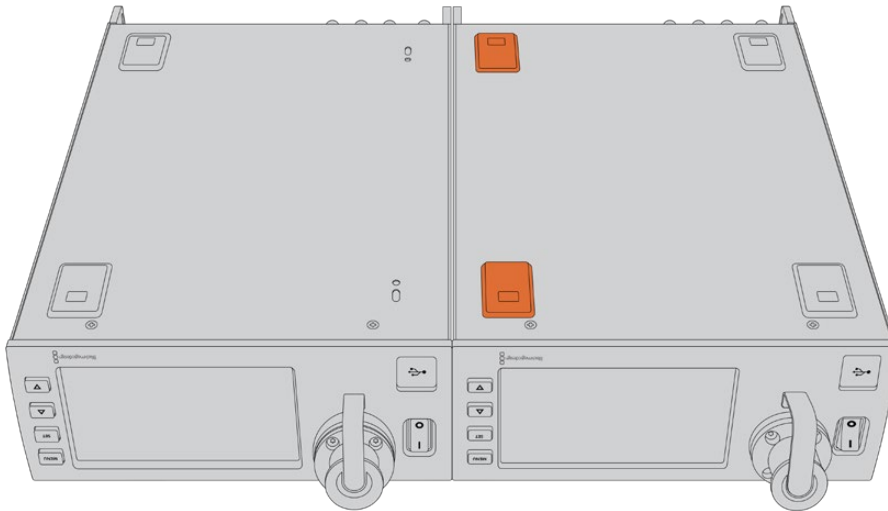

- 2 Attach the two supplied T-shaped support brackets to the base of the two Studio Fiber units at the front and the back where the two units meet, using the screw holes provided and the supplied support bracket screws.

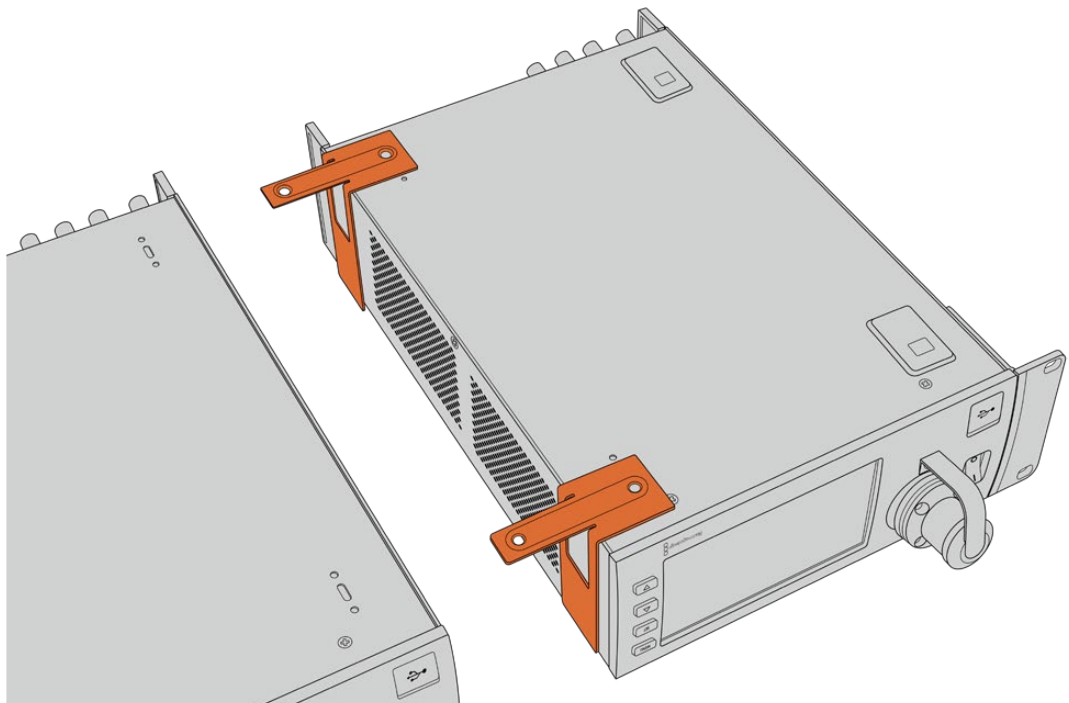

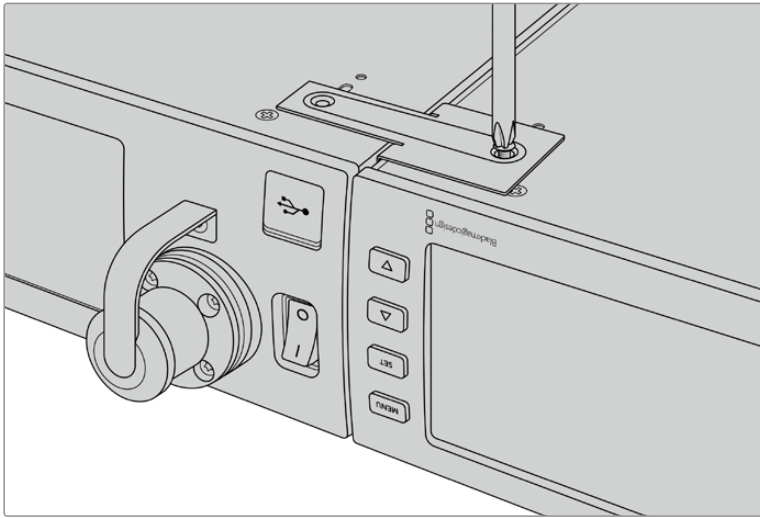

- 3 Turn the attached units back over and attach the rack ears to the outer edges near the front of both converters, using the supplied rack ear screws. Your converters are now ready to be installed into a rack using the mounting holes on both sides and standard rack screws.

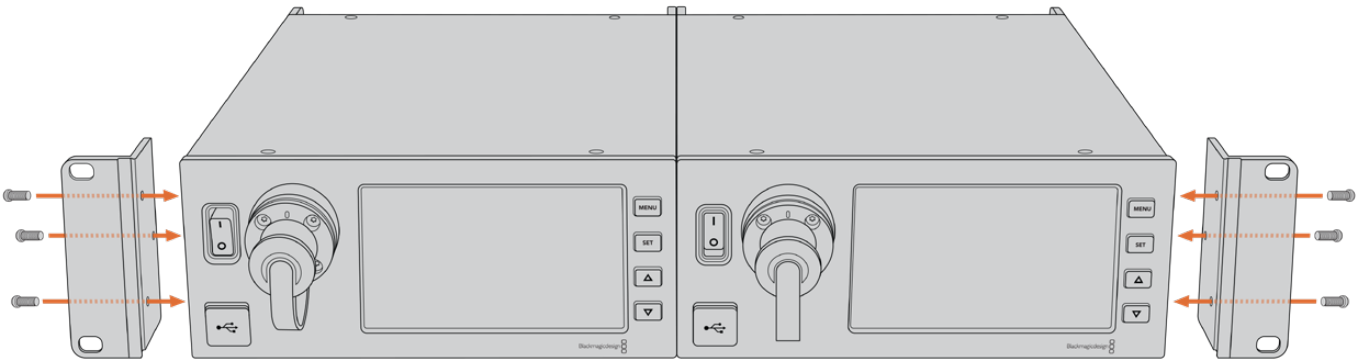

# Camera Unit Connections

Connections are located on Blackmagic Camera Fiber Converter's rear and side panels. When the connections are not in use, the rubber caps should be replaced to ensure weather sealing in rain and other outside environments. This is especially true for the SMPTE fiber connection, as dust particles can very quickly collect on the polished edge of the glass fibers which can disrupt signal flow. It's always a wise choice to remove the caps on both the cable and unit connector immediately before connection, and then replace the caps immediately after disconnection.

## Camera Power Connection

Power is primarily supplied to the camera unit and your camera from the studio converter via a SMPTE hybrid fiber cable. This also powers all accessories that may be attached to the camera, for example Blackmagic URSA Studio Viewfinder.

However, you can also power the Blackmagic Camera Fiber Converter via the camera if your camera has its 12V XLR connector plugged into a power supply. This is not normally required, but is an option if you have your camera positioned further than 2 kilometers away from the studio unit where power may not be as reliable over the SMPTE fiber cable.

## PTZ Interface

The DE-9 serial connector allows you to connect to a PTZ motorized head. For example, if your Blackmagic URSA Mini or URSA Broadcast is attached to a camera crane using a pan, tilt, zoom head that is controlled remotely. You can select the source of PTZ commands being sent to your camera in the menu of your Blackmagic Studio Fiber Converter. The source of the commands can be set to the DE-9 connector on your Studio Fiber Converter or an SDI feed coming from an ATEM switcher. For more information refer to the 'operating the studio fiber converter' section.

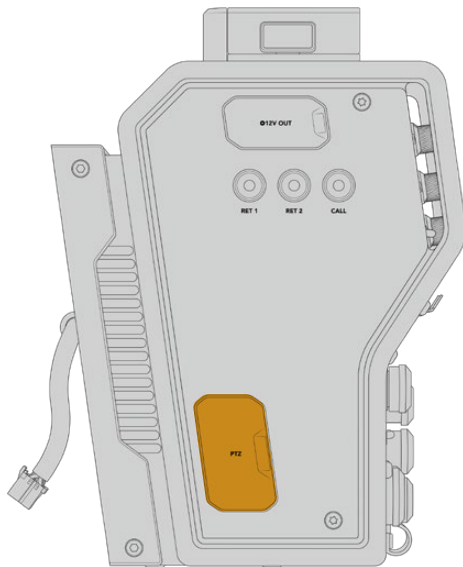

PTZ Interface

## Talkback Connection

The two female 5 pin XLR connectors let you plug in two headsets, which allows two people to communicate via talkback simultaneously. For example, the camera operator's headset can be plugged into the first XLR connector, and a crane operator or fellow crew member, such as a sound operator, could plug into the second XLR headset connector. A pinout diagram for the headset XLR connector is included below.

### Headset XLR Pinout Diagram

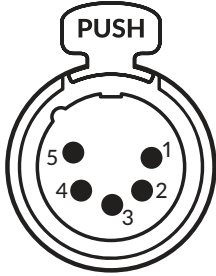
External view	Pins	Signal	I/O	Specifications
 <p>5-pin XLR 'headset' connector</p>	1	Intercom MIC (Y)	GND	The intercom mic input supports electret condenser mics and dynamic mics, which can be balanced or unbalanced. Pin 1 is the mic signal common, and pin 2 is the mic signal input for both types. With electret mics, a DC bias supply is also output via the same mic signal input pin.
	2	Intercom MIC (X)	In	
	3	GND	GND	GND
	4	Intercom left	Out	
	5	Intercom right	Out	

The corresponding intercom controls are located above each headset connection.

For more information on how to use the intercom controls, refer to the 'Operating the Camera Fiber Converter' section.

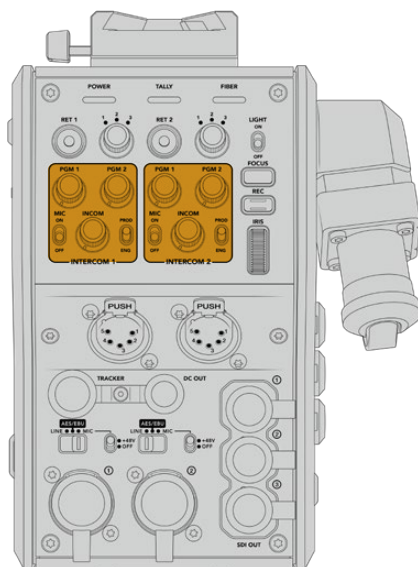

The intercom controls are used to mix talkback audio levels

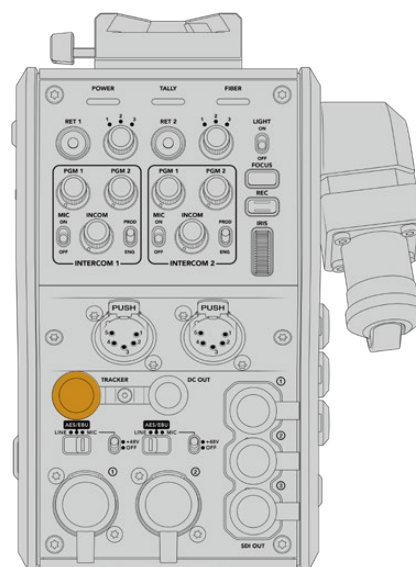

Tracker Interface connector

## Tracker Interface

The 10 pin 'tracker' connector provides a multiplexed output for talkback and tally signals, plus data such as teleprompter information. This output is commonly used by support crew operating production equipment such as a camera crane.

A pinout diagram is provided in this section if you want to build your own cable.

### Tracker Output Pinout Diagram

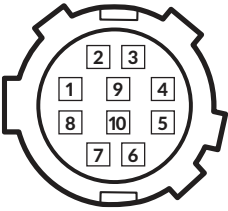
External view	Pins	Signal	I/O	Specifications
 <p>10 pin 'tracker' connector</p>	1	Tracker left	Out	Tracker output, -20 dBu unbalanced
	2	GND (Talk)	-	GND for tracker talk
	3	GND (Receive/PGM/tally)	-	GND for receive/PGM/tally
	4	Tracker right	Out	Tracker output, -20 dBu unbalanced
	5	Unregulated	Out	12V DC (nom), 500mA (max)
	6	GND (Unregulated)	-	GND for unregulated
	7	Tracker talk (X)	In	Tracker talk 0 dBu /-20 dBu, high impedance balanced
	8	Tracker talk (Y)	In	
	9	G Tally	Out	On: 12V Off: high impedance (open)
	10	R Tally	Out	On: 12V Off: high impedance (open)

## DC Connection

You can power additional accessories, for example an external monitor, via the DC out connector.

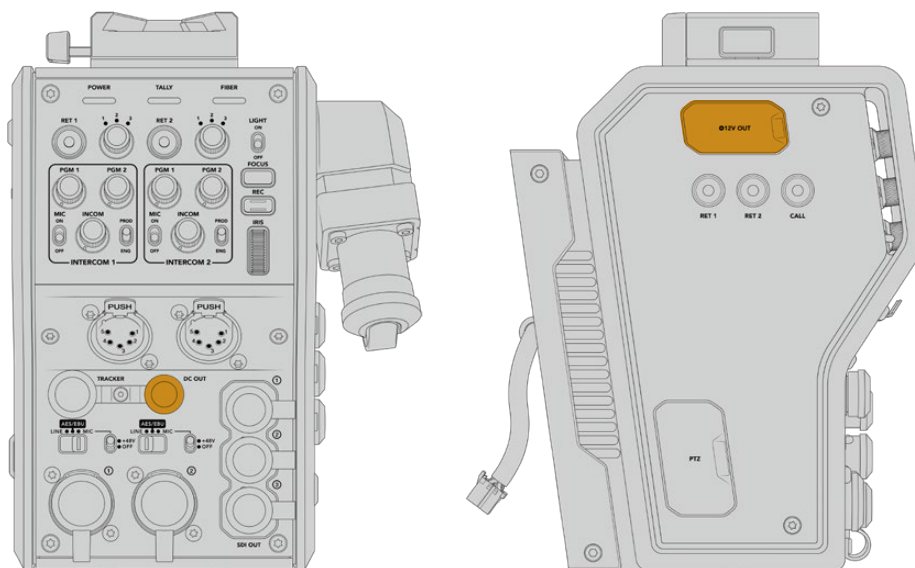

The DC out connector lets you power additional accessories, such as a monitor or external recording equipment

D-Tap Output

## D-Tap Output

The +12V output on the left side panel is often referred to as a 'D-tap' or 'P-tap' and lets you power accessories like a monitor or a large box lens. The output supports box lenses that require 12 Volts DC nominal at 2 amps.

## Reference Output and Operation

The reference output can be used to connect a reference signal to your camera via a BNC cable.

To connect a reference signal to your camera:

- 1 Connect the reference output from the Blackmagic Camera Fiber Converter, marked 'REF OUT', to the reference input on your camera marked 'REF IN' using one of the small SDI cables supplied with your camera fiber converter.
- 2 Set your camera's reference setting to the reference input.

A sync reference signal lets you genlock video equipment to a common reference, so all equipment shares the exact same timing. This means all video sources are synced and will switch smoothly.

ATEM switchers have built in re-synchronizers, so if you are using Blackmagic cameras with an ATEM Switcher then you don't need to worry about connecting a sync reference. The camera will lock to the incoming SDI program feed from the ATEM switcher, so all you need to do is make sure the 'program' input is selected in your URSA Mini or URSA Broadcast's reference setting on page two of the 'setup' menu. The re-synchronizing process will add a frame delay.

If you want to reduce the latency of the re-synchronizing process within the ATEM, firstly apply a reference signal to the URSA Mini or URSA Broadcast, then adjust the back timing so the line input is before the switch timing of the ATEM.

To adjust the reference sync on the URSA Mini or URSA Broadcast, enter the 'setup' menu and change the settings for 'reference timing'.

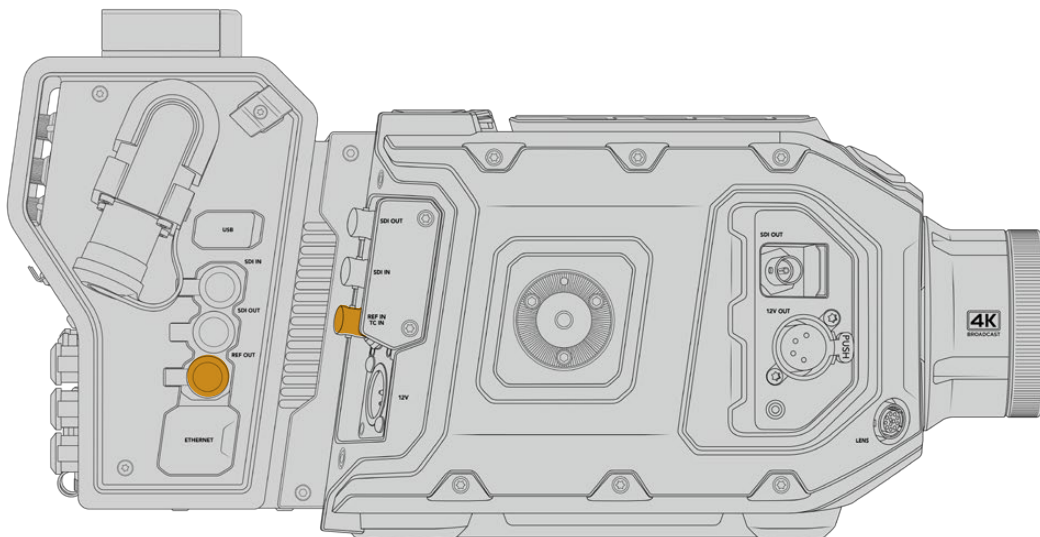

If you're using an external reference signal, connect the reference output from the camera fiber unit to URSA Mini or URSA Broadcast's reference input.

# Studio Unit Connections

The rear panel of the Blackmagic Studio Fiber Converter provide SDI return feed and reference BNC connectors, intercom and tally DB-25 connector, PTZ 9 pin serial port, audio outputs, and Ethernet.

All SDI inputs support 12G-SDI for video formats up to Ultra HD 2160p60.

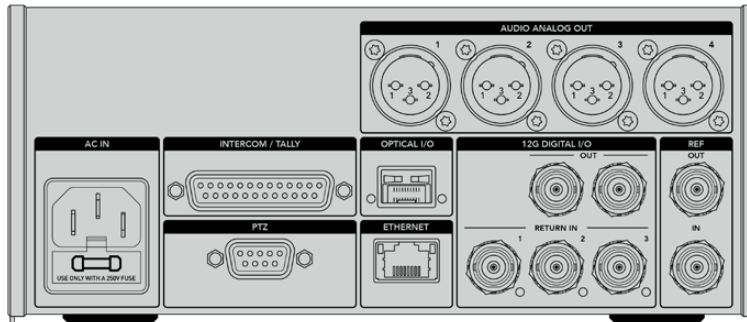

## 12G-SDI Output

The two 12G-SDI outputs are for connecting the camera signal from the studio unit to any of your switcher's camera SDI inputs. The second connector can be used to output the same signal to other video equipment, for example a Blackmagic Videohub router, SmartView monitor or a HyperDeck Disk Recorder.

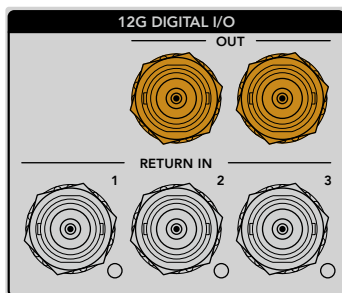

The 12G-SDI outputs allow for signals from 720p50 up to 2160p60

## Return SDI Inputs

The 12G-SDI return feed BNC connectors give you the option to plug in up to three return SDI feeds. For example, the program feed from a switcher should be connected to return 1 and have a matched frame rate to that of your camera. Other sources like a second camera output, HyperDeck playback, or even a teleprompter can be connected to return feeds 2 and 3. If you are using an ATEM switcher, the program return connected to return 1 will also include tally, talkback, reference and camera control signals.

The return SDI inputs allow you to connect up to three return feeds from your switcher. These feeds will be fed to your camera so that they can be viewed by the camera operator, or fed out via SDI to other equipment.

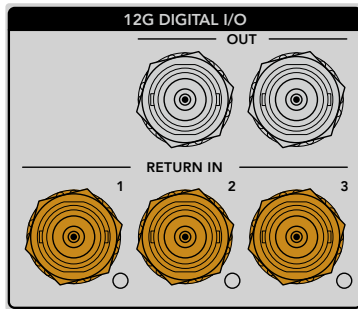

**NOTE** If you connect Ultra HD to the return inputs, the Ultra HD video will be down converted to 1080p at the same frame rate, so the output from the camera unit will be HD. Down converting the Ultra HD return signals to HD allows for greater bandwidth so you can send multiple return sources.

## Reference Input and Output

If you are not using an ATEM switcher and need to lock equipment to a common external reference signal, plug the externally generated signal into the reference BNC input. This sends the reference to the camera unit via the SMPTE fiber cable. The reference BNC output from the studio unit can be used to loop the reference source to other equipment.

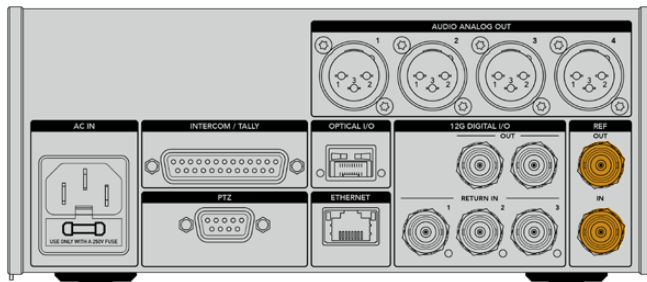

Use the 'ref in' connection to send traditional reference timing from other broadcast equipment to your camera

## Talkback Interface

The DB-25 intercom and tally connector lets you connect to third party intercom and tally systems. A pin out diagram is provided below if you need to build a custom cable. Once you have wired up to the pins for engineering, production, tally or program audio input, you will need to set the menu accordingly on your Blackmagic Studio Fiber Converter.



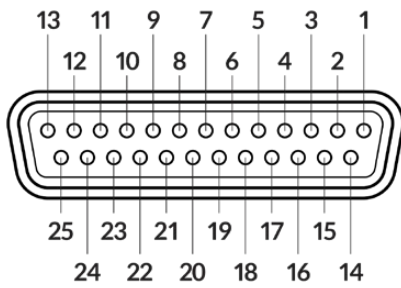

The external view of the 25 pin 'intercom/tally' connector

#### Talkback Pinout Diagram

Pins	Signal	Specifications
1	ENG(R) IN+	Engineering channel input 0dBu balanced
2	ENG(R) IN-	
3	ENG GND	GND for ENG
4	ENG(T) OUT +	Engineering channel output 0dBu balanced
5	ENG(T) OUT -	
6	PGM IN+	-20dBu
7	PGM IN-	-20dBu
8	PGM GND	-20dBu
9	GND	GND for aux
10	N/C	-
11	Red Tally IN	On = 5-24Vdc, Off= 0Vdc
12	Red Tally GND	-
13	GND	Chassis GND
14	PROD(R) IN+	Production channel input 0dBu balanced
15	PROD(R) IN-	
16	PROD GND	-
17	PROD(T) OUT+	Production channel output 0dBu balanced
18	PROD(T) OUT-	
19	N/C	-
20	N/C	-
21	N/C	-
22	N/C	-
23	N/C	-
24	Green Tally IN	On = 5-24Vdc, Off= 0Vdc
25	Green Tally GND	-

## PTZ Interface

Both the studio unit and camera unit has a 9 pin DE-9 connector so you can connect a PTZ controller at the studio end, and the remote head at the camera end. The PTZ commands are embedded in the SDI signal connected between the units via the SMPTE fiber cable.

The settings menu on Blackmagic Studio Fiber Converter lets you select the source of PTZ commands that are sent to your Blackmagic Camera Fiber Converter. You have the option to select from the PTZ connector on the back of the Studio Fiber Converter or a program SDI feed coming from an ATEM Switcher instead. For more information, refer to the 'operating the studio fiber converter' section.

### PTZ Interface Pinout Diagram

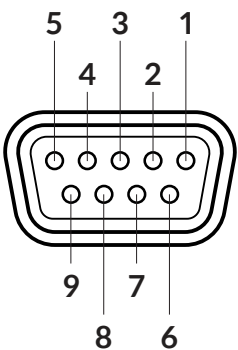
External view	Pins	Signal
 <p>9 pin 'PTZ' connector</p>	1	GND
	2	RS422 Tx-
	3	RS422 Rx+
	4	GND
	5	N/C
	6	GND
	7	RS422 Tx+
	8	RS422 Rx-
	9	GND

## Audio Outputs

The four XLR audio outputs on the studio unit give you the option to output the audio plugged into inputs 1 and 2 from your URSA Mini or URSA Broadcast camera, and the two XLR audio inputs on the Camera Fiber Converter.

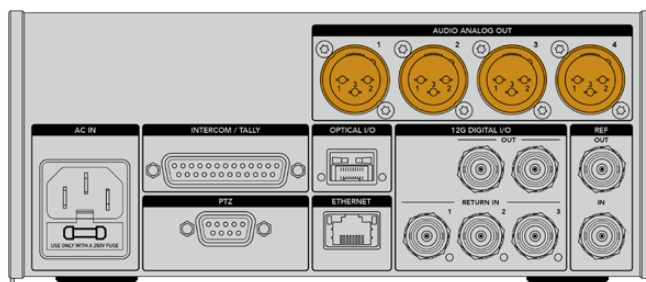

Outputs 1 and 2 on the studio unit correspond to embedded XLR input channels 1 and 2 on URSA Broadcast or URSA Mini by default. Outputs 3 and 4 on the studio unit correspond to XLR inputs 1 and 2 on the Blackmagic Camera Fiber Converter by default. You can use the menu to change these settings for mapping. For more information, see the 'using the menu' section.

## Updating Internal Software

From time to time Blackmagic Design releases updates that can enhance and enable features on your Blackmagic Fiber Converters. We recommend checking the Blackmagic Design website regularly to ensure your fiber converters are using the latest internal software. Update your Fiber Converters using the Blackmagic Camera Setup Utility software.

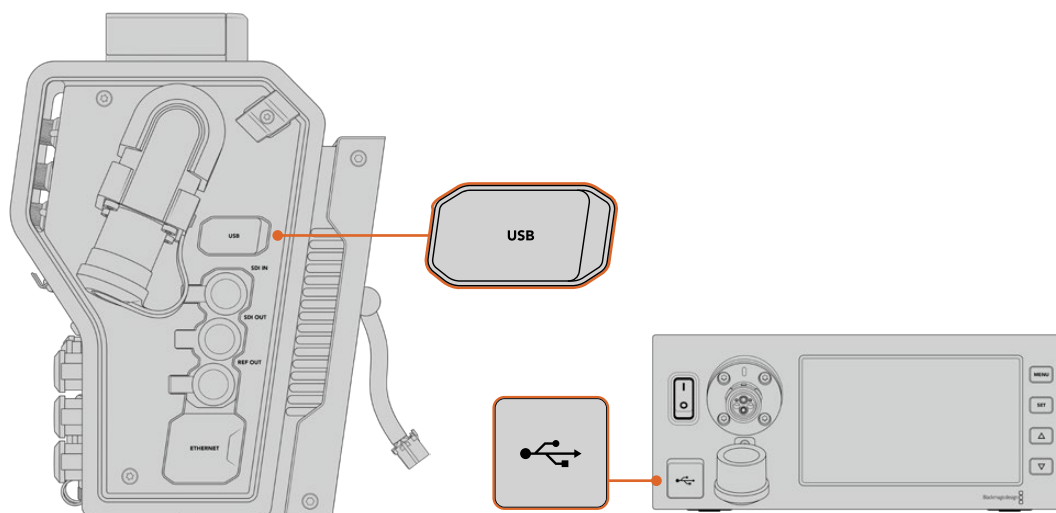

The USB-C ports on the Blackmagic Fiber converters let you update their internal software.

### Updating Blackmagic Camera Fiber Converter

Your Camera Fiber Converter will need to be powered when updating, so we recommend keeping the converter connected to URSA Mini or URSA Broadcast during the update process.

It's important that you unplug the SMPTE Fiber cable from your Camera Fiber Converter, and power your camera via the supplied URSA camera Power Supply instead for consistent power.

Blackmagic Camera Fiber Converter has a USB-C connector on the right side of the unit for updating its internal software. Connect your computer to this USB connector and launch Blackmagic Camera Setup Utility. You will be prompted to update if your computer detects that your Camera Fiber Converter is using an outdated version. Follow the on screen prompts to update your converter's internal software.

### Updating Blackmagic Studio Fiber Converter

Your Studio Fiber Converter will need to be powered when updating, so we recommend keeping the IEC power cable plugged into the power connector on the studio unit's rear panel during the update process.

Blackmagic Studio Fiber Converter has a USB-C connector on the front of the unit for updating its internal software. Connect your computer to this USB connector and launch Blackmagic Camera Setup Utility. You will be prompted to update if your computer detects that your Studio Fiber Converter is using an outdated version. Follow the on screen prompts to update your converter's internal software.

# Interchangeable Lens Mount

Blackmagic URSA Mini Pro 12K is shipped with a PL mount. Other URSA Mini Pro cameras are shipped with an EF mount attached. All URSA Mini Pro cameras have interchangeable lens mounts so you are not locked into using lenses to match the lens mount supplied with your camera. This means you can remove the original mount and attach an optional PL, B4, F or EF mount. Contact your local Blackmagic Design reseller to purchase URSA Mini Pro PL Mount, URSA Mini Pro B4 Mount, URSA Mini Pro F Mount or URSA Mini Pro EF Mount.

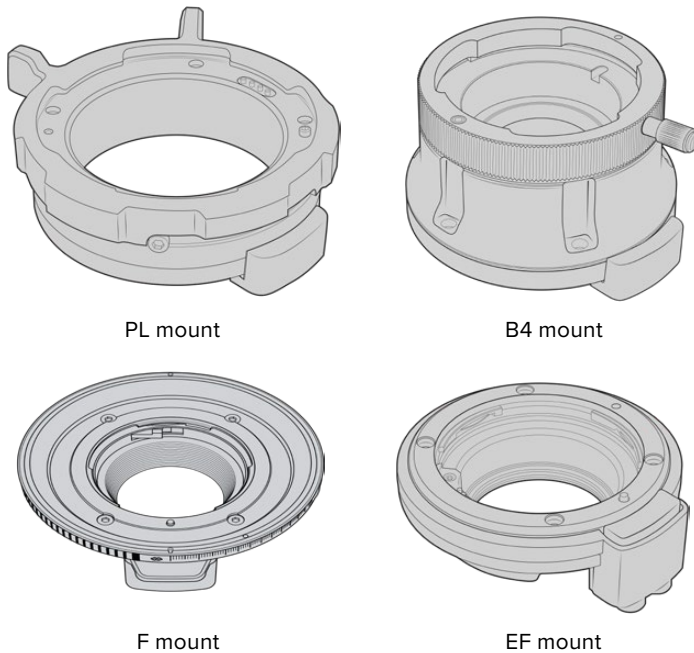

With the ability to interchange three separate mounts, you have the freedom to use different lenses based on the type of assignments you're working on. For example, the EF mount lets you use high quality stills lenses, the B4 mount is perfect if you want to use par-focal zoom lenses for electronic news gathering or wedding shoots, and the PL mount lets you use high end, robust cinema lenses designed for absolute precision and repeatable control.

Attaching each mount is as simple as unscrewing the original mount and replacing it with the new mount. It's very easy!

## To remove the original PL Mount from URSA Mini Pro 12K:

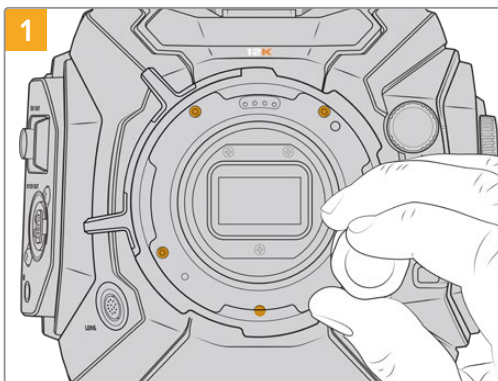

The original PL mount is removed from your URSA Mini Pro 12K by unscrewing the five screws with a 2mm Hex driver

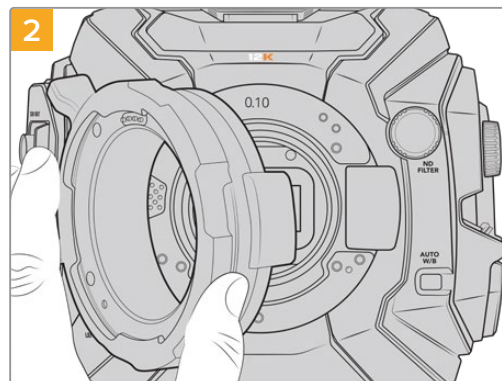

Gently lift the mount from the camera body

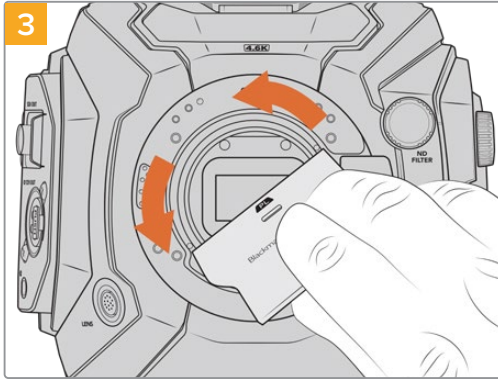

After you remove the PL lens mount, use the wide end of the baffle tool to loosen the PL baffle in the center and then unscrew it carefully using your fingers

**To remove the original EF Mount from URSA Mini Pro 4.6K G2 or URSA Mini Pro 4.6K:**

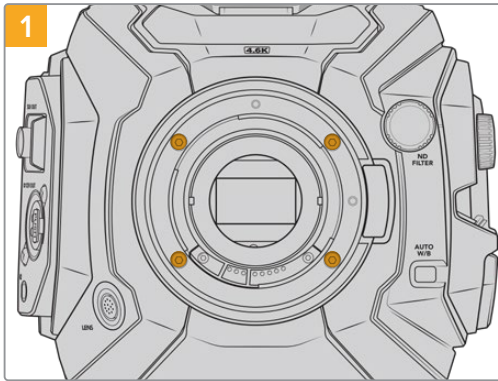

The original EF mount is easily removed from URSA Mini Pro 4.6K G2 or URSA Mini Pro 4.6K by unscrewing the four screws with a 2mm Hex driver

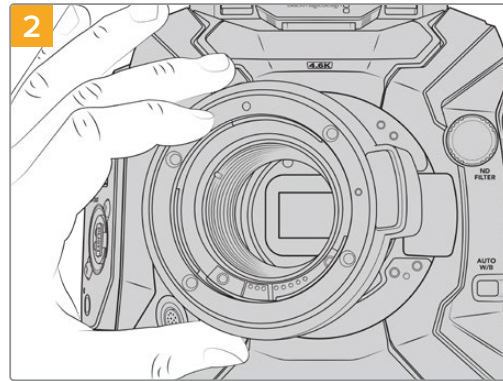

Gently lift the mount from the camera body

**NOTE** When removing the original lens mount, make sure the shims underneath the mount always stay attached to your camera.

Keep reading this section for details about the PL, B4, F and EF lens mount kits and how to install each mount to your URSA Mini Pro.

## Blackmagic URSA Mini Pro PL Mount

Attaching the PL mount to your URSA Mini Pro lets you use high end precision cinema lenses for feature film and television production.

### The PL mount kit includes:

---

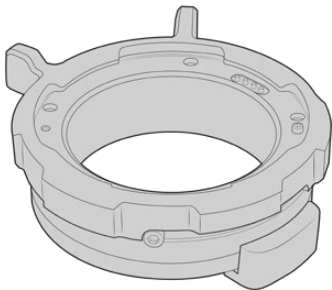

#### 1 x PL mount

The PL mount is shipped with a protective dust cap.

---



#### 1 x Shim set

The shim set includes the following thicknesses:

0.50mm	0.18mm	0.10mm
0.30mm	0.15mm	0.05mm
0.20mm	0.12mm	0.025mm

---

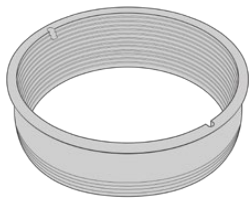

#### 1 x PL baffle

The PL mount baffle helps to control and direct the light entering the sensor.

---



#### 1 x Baffle tool

Use the PL baffle tool to tighten the baffle in your camera.

---

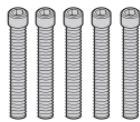

#### 5 x 2mm Hex M2.5 x 22mm mount screws

The five M2.5 x 22mm Hex screws are exclusive to the PL mount so you can keep the screws together with the respective mount.

The PL mount kit also comes with a full spare sets of screws in case the originals are misplaced.

---

### Tools Required

When attaching the PL mount, you will need a 2mm Hex driver. While it's not absolutely required, we recommend using a torque wrench able to accurately set a maximum torque of 0.45Nm to reduce the potential of over tightening the screws.

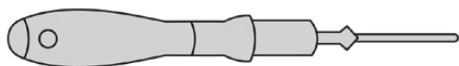

2mm Hex driver

## Attaching the PL Mount

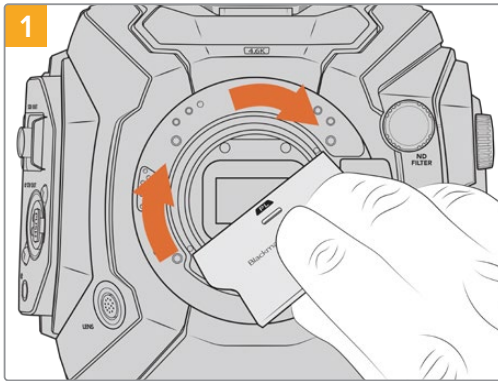

Gently insert the PL baffle into the center of the lens mount and turn until it is finger tight. Use the wide end of the baffle tool to tighten the baffle slightly. You need just enough pressure to keep it in place.

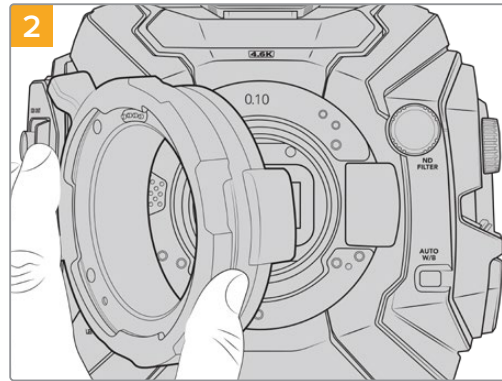

Carefully place the Blackmagic URSA Mini Pro PL lens mount onto the camera body. Ensure the pins on the PL mount for Cooke /i Technology are located at the 12 o'clock position.

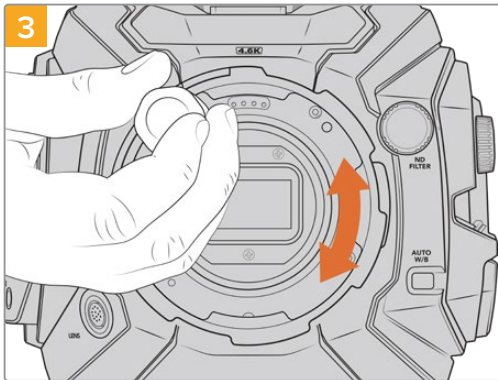

Using a 2mm Hex driver or torque wrench set to 0.45Nm, loosely turn the five mounting screws until initial contact is made with the shoulder of the lens mount. To access all five screws, you will need to rotate the PL locking ring, as some holes are obscured when the ring is either open or closed.

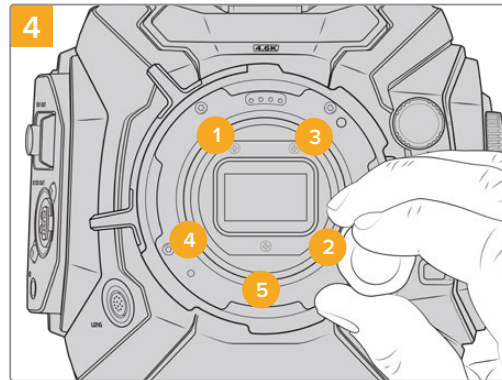

Confirm the lens mount is level and correctly aligned, then tighten the screws in the order shown here to an even pressure without overtightening the screws.

**NOTE** When removing the PL mount, simply follow the instructions in reverse order from step 4 to step 1. Don't forget to remove the PL baffle and store it securely with the PL mount.



## Blackmagic URSA Mini Pro F Mount

With the F mount attached to your URSA Mini Pro, you can use F mount lenses. Nikon's F mount system stretches back to 1959, and F mount lenses are still made today. This means that with the Blackmagic URSA Mini Pro F mount, you have access to a huge range of vintage and contemporary lenses.

It's worth noting that Blackmagic URSA Mini Pro F mount is a mechanical mount. This means it does not offer electronic focus or iris control. Instead, Blackmagic URSA Mini Pro F mount features a mechanical iris adjuster. This moves the iris pin present in most Nikon lenses to achieve smooth cine style iris adjustment.

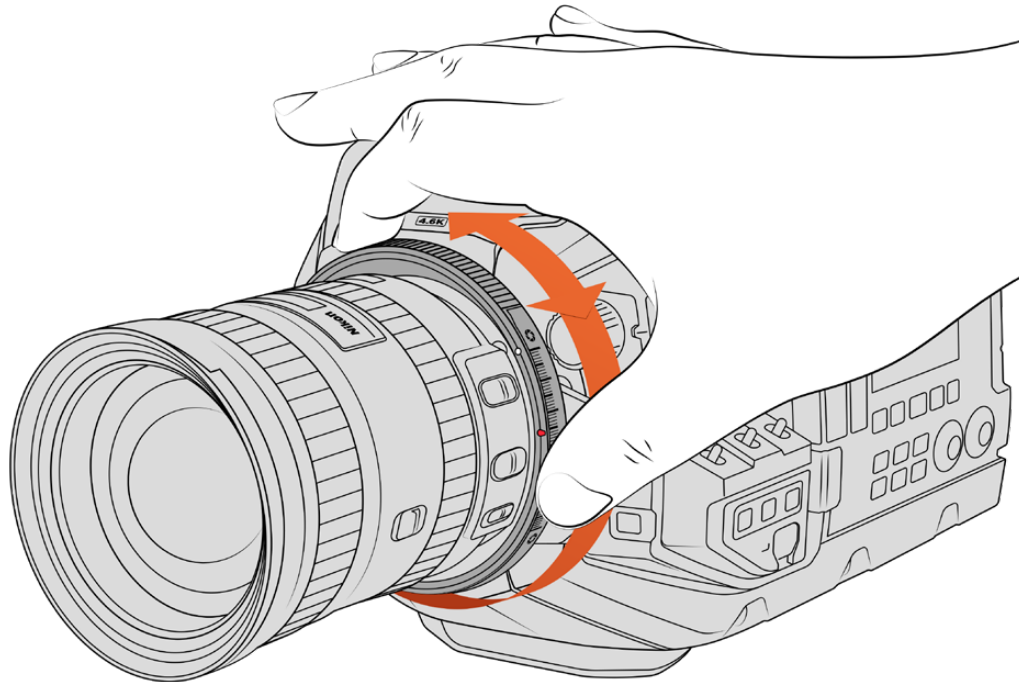

Use URSA Mini Pro F mount's iris adjustment ring to smoothly change the aperture of F mount lenses.

With an F mount mounted, simply move the iris adjuster on Blackmagic URSA Mini Pro F mount to achieve your preferred exposure. The red dot on the F mount and the markings on the iris adjuster let you mark iris settings to easily return to particular exposure or depth of field settings.

**NOTE** Because of the way URSA Mini Pro F mount works, a small number of F mount lenses are not compatible.

These are Nikkor AF-S E series lenses, which do not offer mechanical iris control, and Nikon PC-E tilt-shift lenses like the 24mm f/3.5D PC-E and 85mm PC-E.



## Nikon AF-D lenses

When using Nikon AF-D series lenses, it is necessary to lock your lens aperture to its smallest setting, such as f/22, to use the full range of Blackmagic URSA Mini Pro F mount's iris adjustment ring.

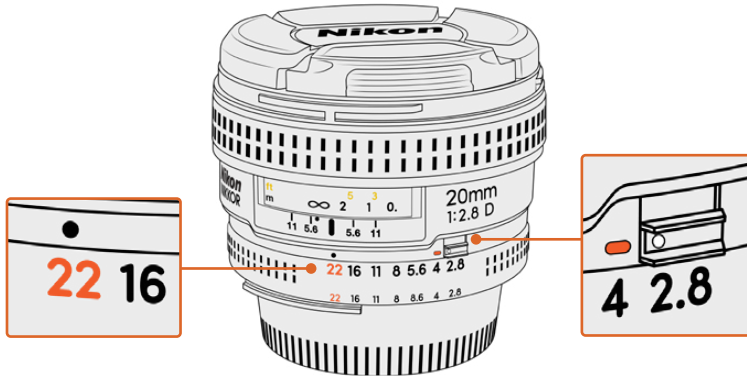

Setting and locking AF-D lenses to their smallest aperture is easiest before mounting to your camera.

### The F mount kit includes:

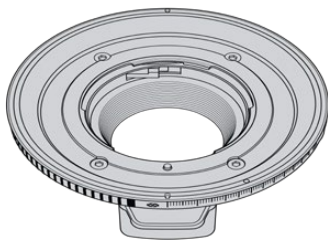

#### 1 x F mount

The F mount lets you attach common F stills lenses.



#### 1 x Shim set

The shim set includes the following thicknesses:

0.50mm	0.18mm	0.10mm
0.30mm	0.15mm	0.05mm
0.20mm	0.12mm	0.025mm

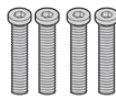

#### 4 x 2mm Hex M3 x 18mm mount screws

The four M3 x 18mm Hex screws are used in the EF and F mount so it is best to keep the screws together with the respective mount.

The F mount kit also comes with a full spare sets of screws in case the originals are misplaced.

### Tools Required

When attaching the F mount, you will need a 2mm Hex driver. While it's not absolutely required, we recommend using a torque wrench able to accurately set a maximum torque of 0.45Nm to reduce the potential of over tightening the screws.

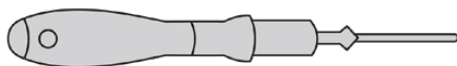

2mm Hex driver

## Attaching the F Mount

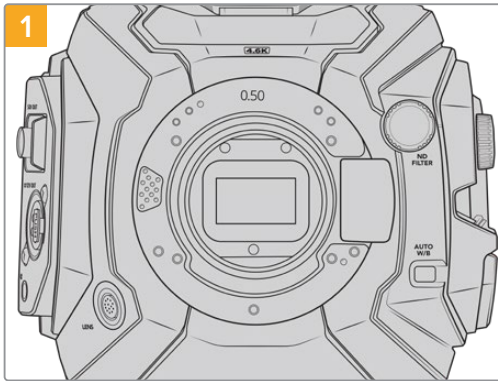

Place Blackmagic URSA Mini Pro vertically on a solid, clean bench top to ensure the mount can be attached vertically. If changing from the PL to the F mount, ensure that you have removed the PL baffle before inserting the F mount.

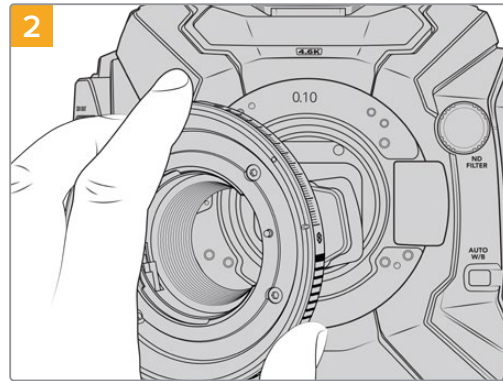

Carefully place the Blackmagic URSA Mini Pro F mount onto the camera body ensuring the white dot is at the 2 o'clock position.

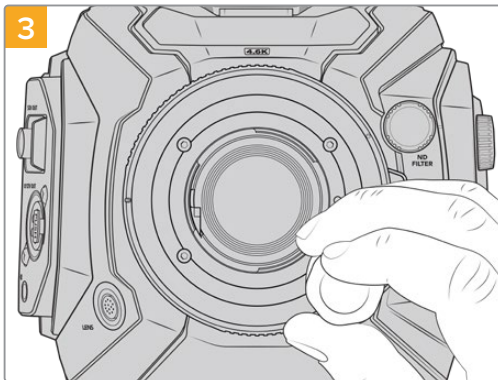

Using a 2mm Hex driver or torque wrench set to 0.45Nm, loosely turn the four mounting screws until initial contact is made with the shoulder of the lens mount.

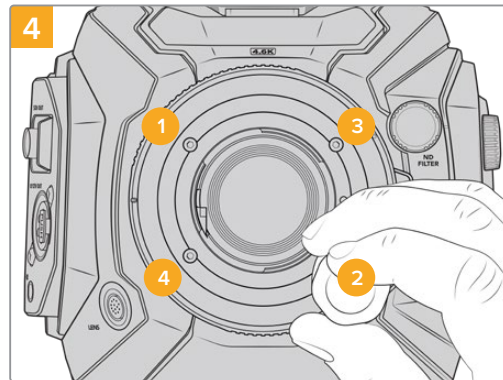

Confirm the lens mount is level and correctly aligned, then tighten the screws in the order shown here to an even pressure without over-tightening the screws.

**NOTE** When removing the F mount, simply follow the instructions in reverse order from step 4 to step 1.

## Blackmagic URSA Mini Pro EF Mount

Blackmagic URSA Mini Pro EF Mount supports an extensive range of EF stills and cinema lenses.

### The EF mount kit includes:

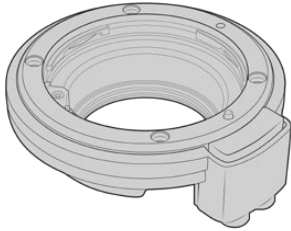

#### 1 x EF mount

The EF mount lets you attach common EF stills lenses.



#### 1 x Shim set

The shim set includes the following thicknesses:

0.50mm	0.18mm	0.10mm
0.30mm	0.15mm	0.05mm
0.20mm	0.12mm	0.025mm

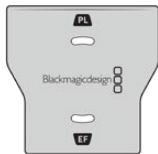

#### 1 x Baffle tool

The baffle in the EF mount is not removable, however we have included a baffle tool in the EF kit as a spare item you can use if you also have the PL mount.

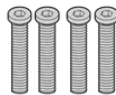

#### 4 x 2mm Hex M3 x 18mm mount screws

The four M3 x 18mm Hex screws are used in the EF and F mount so it is best to keep the screws together with the respective mount.

The EF mount kit also comes with a full spare sets of screws in case the originals are misplaced.

### Tools Required

When attaching the EF mount, you will need a 2mm Hex driver. While it's not absolutely required, we recommend using a torque wrench able to accurately set a maximum torque of 0.45Nm to reduce the potential of over tightening the screws.

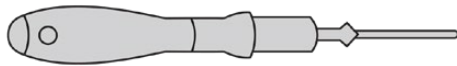

2mm Hex driver

## Attaching the EF Mount

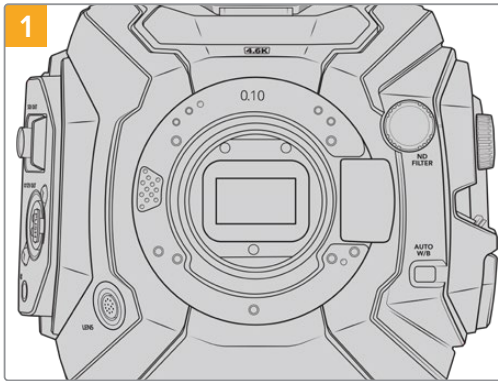

Place Blackmagic URSA Mini Pro vertically on a solid, clean bench top to ensure that the mount can be inserted vertically. If changing from the PL to the EF mount, ensure that you have removed the PL baffle before inserting the EF mount.

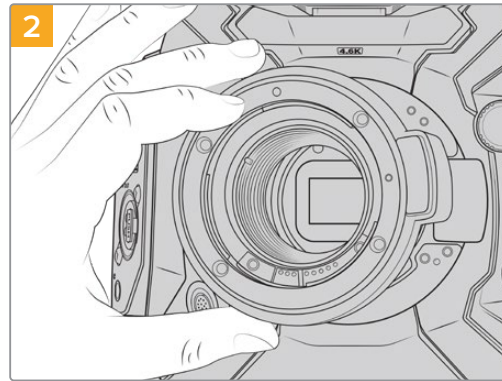

Carefully place the Blackmagic URSA Mini Pro EF lens mount onto the camera body ensuring the red dot is at the 12 o'clock position.

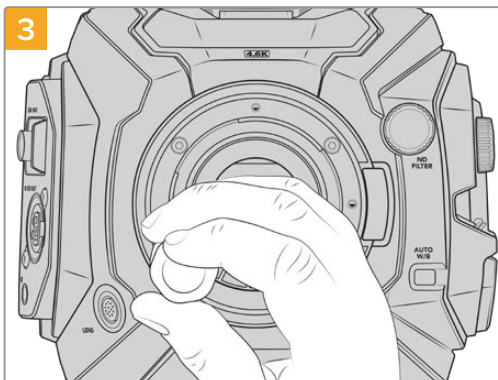

Using a 2mm Hex driver or torque wrench set to 0.45Nm, loosely turn the four mounting screws until initial contact is made with the shoulder of the lens mount.

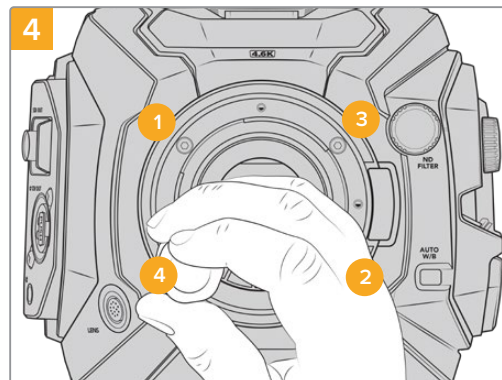

Confirm the lens mount is level and correctly aligned, then tighten the screws in the order shown here to an even pressure without over-tightening the screws.

**NOTE** When removing the EF mount, simply follow the instructions in reverse order from step 4 to step 1.

## Blackmagic URSA Mini Pro B4 Mount

With the B4 mount attached to your URSA Mini Pro 4.6K G2 or URSA Mini Pro 4.6K, you can mount par-focal zoom lenses commonly used for electronic news gathering and wedding videos. These lenses maintain focus throughout large zoom ranges and typically have manual focus and iris control, plus a zoom rocker on the hand grip allowing you to smoothly ease in and out of the zoom. For single operators, using these lenses makes shooting very fast and efficient with exceptional control over the shot. It is important to note that Blackmagic URSA Mini Pro B4 mount is not compatible with URSA Mini Pro 12K.

### The B4 mount kit includes:

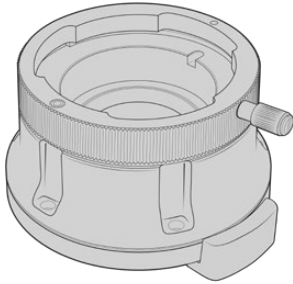

#### 1 x B4 mount

The B4 mount lets you use industry standard ENG lenses with your URSA Mini Pro.



#### 1 x Shim set

The shim set includes the following thicknesses:

0.50mm	0.18mm	0.10mm
0.30mm	0.15mm	0.05mm
0.20mm	0.12mm	0.025mm



#### 5 x 2mm Hex M2.5 x 12mm mount screws

The five M2.5 x 12mm HEX screws are exclusive to the B4 so you can keep the screws together with the respective mount.

The B4 mount kit also comes with a full spare sets of screws in case the originals are misplaced.

### Tools Required

When attaching the B4 mount, you will need a 2mm Hex driver. While it's not absolutely required, we recommend using a torque wrench able to accurately set a maximum torque of 0.45Nm to reduce the potential of over tightening the screws.

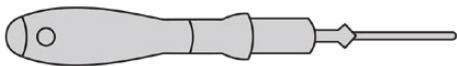

2mm Hex driver

## Attaching the B4 Mount

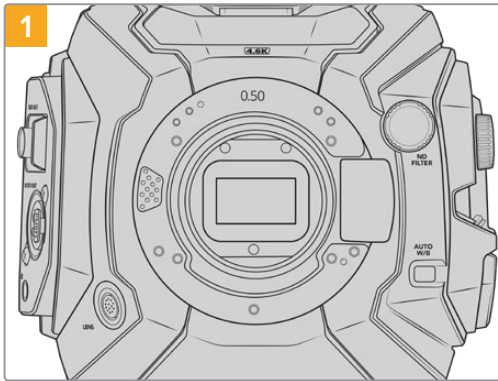

Place Blackmagic URSA Mini Pro vertically on a solid, clean bench top to ensure that the mount can be inserted vertically.

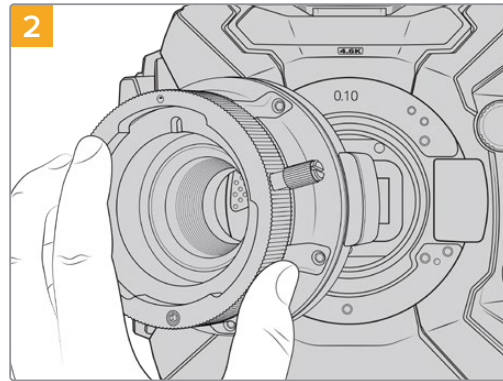

Carefully place the Blackmagic URSA Mini Pro B4 lens mount onto the camera body ensuring the red dot is at the 12 o'clock position.

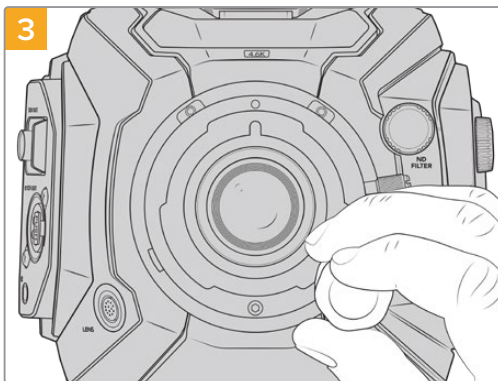

Using a 2mm Hex driver or torque wrench set to 0.45Nm, loosely turn the five mounting screws until initial contact is made with the shoulder of the lens mount.

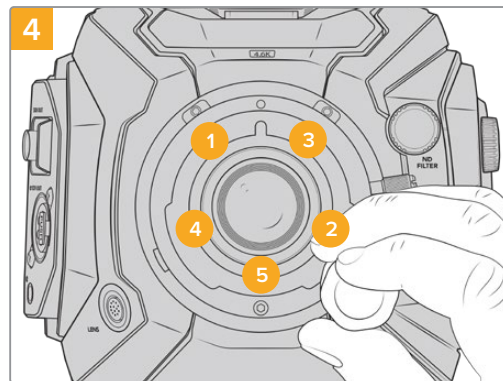

Confirm the lens mount is level and correctly aligned, then tighten the screws in the order shown here to an even pressure without over-tightening the screws.

**NOTE** When removing the B4 mount, simply follow the instructions in reverse order from step 4 to step 1.

**TIP** When using a B4 lens with URSA Mini Pro 4.6K G2 or URSA Mini Pro 4.6K, set the resolution to 2K 16:9 or lower, and 'window sensor' to 'on' in the 'record' tab of the dashboard. It is important to use these settings to prevent vignetting of the image, as B4 lenses do not cover the super 35mm image circle. Once you have attached a B4 lens and adjusted the settings on your camera, you should also check the back focus on the lens.

## Blackmagic URSA Mini Pro Shim Kit

When attaching the PL, B4 or F mounts to URSA Mini Pro, a 0.10mm shim is added to the original 0.50mm and 0.10mm shims underneath the original EF mount. This shim and others are included in the Blackmagic URSA Mini Pro Shim Kit. Other thicknesses are included in the kit in case you need to re-shim your camera to suit PL lenses that may require slightly different clearances to maintain accurate focus marks.

### The shim kit includes:

---



#### 1 x Baffle tool

Use the baffle tool to loosen or tighten the PL baffle when removing or attaching the PL mount to your URSA Mini Pro.



#### 1 x Shim set

The shim set includes the following thicknesses:

0.50mm	0.18mm	0.10mm
0.30mm	0.15mm	0.05mm
0.20mm	0.12mm	0.025mm

---



# Using DaVinci Resolve

Shooting with your Blackmagic URSA Mini is only part of the process of creating film and television content, and just as important is the process of media backup and management as well as editing, color correction and encoding final master files. Your Blackmagic URSA Mini includes a version of DaVinci Resolve for Mac and Windows so you have a complete solution for shooting and post production!

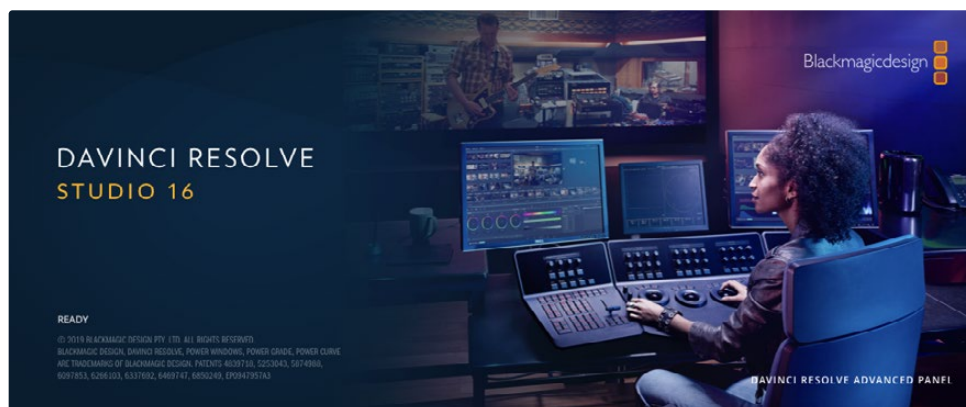

**NOTE** We recommend using the latest version of DaVinci Resolve for accurate color treatment of clips shot using URSA Mini. Version 16.3 or later will provide accurate color for all URSA Mini cameras and the latest Blackmagic RAW features, as well as supporting 12K files.

After connecting your CFast, SD card or SSD to your computer, you can use DaVinci Resolve's 'clone' tool, in the 'media' page, to create running backups as you shoot. This is recommended as any type of media is susceptible to becoming damaged or developing a fault so creating backups means your shots will be immune to loss. Once you have used DaVinci Resolve to backup your media, you can then add your clips to the DaVinci media pool, then edit, color correct, and finish your production without ever having to leave DaVinci Resolve.

DaVinci Resolve is the same tool used on most major blockbuster movies, so it's much more than a simple NLE software tool, as it has extremely advanced technology built in for high end digital film. You get the advantage of this technology when you use DaVinci Resolve to edit and color correct your work.

Included here is information on how to get started using DaVinci Resolve with your camera files. Of course, DaVinci Resolve is extremely advanced and includes a lot more features than you immediately see when first looking at its user interface. To learn more about how to use DaVinci Resolve, please check for the DaVinci Resolve instruction manual on the Blackmagic website, where you can also find many training courses and tutorial videos.

## Project Manager

Before you import your clips and start editing, you will need to set up your project using the project manager.

The project manager is the first screen you will see when launching DaVinci Resolve, but you can open the manager at any time by clicking on the 'home' icon at the bottom right of the user interface. This is helpful when you want to open previous projects and create new ones.



To create a new project, click on 'new project' at the bottom of the window and give your project a name. Click 'create'.

Using the 'cut' page, you can start working on your edit immediately.

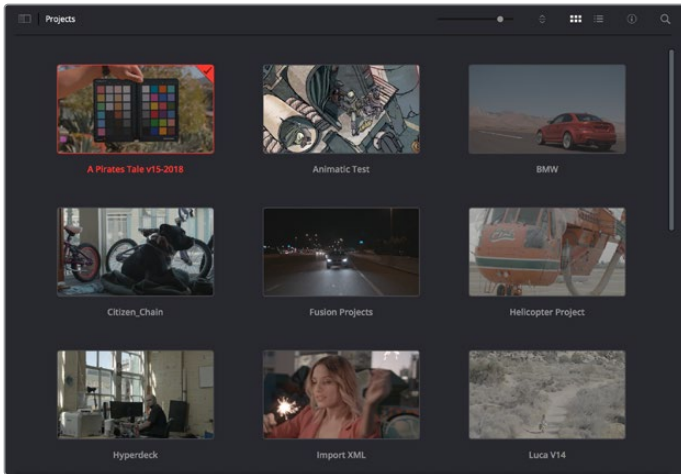

The project manager shows all projects belonging to the current user

For more information about the Project Manager, refer to the DaVinci Resolve manual which is available to download on the Blackmagic Design website support page.

## Editing with the Cut Page

The 'cut' page gives you a fast, dynamic editing workflow that lets you quickly assemble, trim and edit clips efficiently.

Two active timelines let you work with your entire edit plus a detailed area simultaneously. This means you can drop clips anywhere on a large timeline, then refine your edit in a detailed timeline within the same workspace. Using this workflow, you can edit on a laptop without needing to zoom in and out and scroll as you work, which can be an enormous time saver.

### The Cut Page Layout

When you open the cut page, you will see the media pool, viewer window and timeline. These three primary windows give you complete control over your edit.



The 'cut' page default workspace, with the media pool in icon view

For more information on the Cut page, see the 'Using the Cut Page' chapter in the DaVinci Resolve manual.

## Media Tabs

At the top left corner of the user interface you will see five tabs.

Click on these tabs to open the media toolsets you will use when creating your edit. For example, the first tab is the media pool and you can see it is already selected. The other tabs are for the sync bin, media transitions, titles and effects.

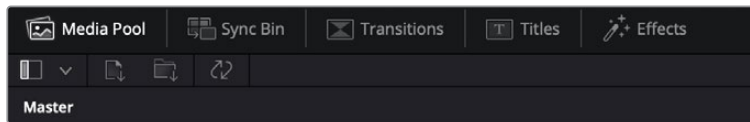

- **Media Pool:** The media pool contains all your clips, folders and files you imported using the media page. You can also import files directly from the cut page, so you don't have to go back to the media page if you want to import a new clip.
- **Sync Bin:** This powerful feature automatically syncs all your clips via timecode, date and time so you can choose angles from all cameras on a multi camera project.
- **Transitions:** If you click on the neighboring transitions tab, you will see all the video and audio transitions you can use in your edit. These include common transitions such as cross dissolves and motion wipes.
- **Titles:** Next to transitions is the 'titles' tab. Here you can select the title type you want to use. For example a scroll, standard text or lower thirds title. There are also a list of Fusion templates you can use for more animated dynamic titles which can be customized in DaVinci Resolve's 'Fusion' page.
- **Effects:** The fifth tab is the 'effects' tab. This provides all the different filters and effects you can use to bring more life to your edit, for example customizable blurs, glows and lens effects. There are many powerful effects to choose from and you can find them quickly using the search tool.

**TIP** Use the search tool near the media tab icons to find the exact items you are looking for. For example, if you have the transitions tab selected, type "dissolve" in the search tool and only dissolve transition types will be shown in the viewer, making it quicker for you to find the dissolve transition you want.



## Viewer Tabs

In the top left corner of the viewer window you will see the viewer mode buttons.



The viewer mode buttons

These buttons control which viewer is currently being used, including 'source clip', 'source tape', and 'timeline'. These viewer modes give you an enormous amount of control when selecting clips for your edit and it's worth spending a moment to look at how they work.

	<b>Source Clip</b>	The source clip viewer displays a single clip from the media pool and you can set in and out points along the entire length of the viewer timeline. This gives you greater control. Select a source clip to view by double clicking on a clip in the media pool, or dragging it into the viewer.
	<b>Source Tape</b>	Source tape lets you view all the source clips in the media pool. This powerful feature is helpful if you want to quickly search through all your clips to find a specific event. As you scrub the playhead over the clips, you will see their thumbnails selected in the media pool. This means once you have found the clip you want to edit, you can click on the source clip tab and its corresponding source clip will appear in the viewer automatically. The source tape viewer really lets you take advantage of non-linear editing, giving you the freedom to work on your edit, find shots quickly, try new ideas and stay in the moment.
	<b>Timeline</b>	The timeline viewer lets you view the edit timeline so you can play back your project and refine your edits.

## Importing Clips to the Media Pool

Now you can start importing media into your project. You can do this in the media pool window of the cut page using the import tools at the top.



Select one of the import options to add media to your project

	<b>Import Media</b>	The import media option will import individual media files selected from your storage location.
	<b>Import Media Folder</b>	To import a folder from your media storage, select the import folder option. When importing a folder, DaVinci Resolve will keep the file structure, treating each folder as a separate bin so you can navigate between bins to find your videos and other media files.

### To import media:

- 1 Click on the 'import media' or 'import media folder' icon.
- 2 Navigate to your media storage for the media you want to import.
- 3 Select the file or folder and click 'open'.

Once you've added media to your project, it is a good time to save your changes. DaVinci Resolve features a fast, on the go autosave called 'live save'. Once you save your project once, 'live save' will save further changes as you make them, removing the risk of losing your work.

For more information on 'live save' and other auto save functions, refer to the DaVinci Resolve Manual.

## Adding Clips to the Timeline

Now that you are familiar with the media tabs and viewer mode buttons, you can open the media pool and quickly start adding clips to your timeline.



The timeline of the cut page, comprising the upper timeline and the zoomed in timeline below

The timeline is where you will build your edit and is like a board with tracks you can attach clips to, move them around and trim their edits. Tracks let you layer clips over others which gives you more flexibility to try different edits and build transitions and effects. For example, you can try an edit with a clip on one track without affecting other clips on tracks below it.

There are different ways to add clips to the timeline, such as smart insert, append, place on top and more.

### Appending Clips

When selecting takes and assembling an edit, you will likely want to add these shots to your timeline one after the other. The append tool is perfect for this task and will get you editing very fast.

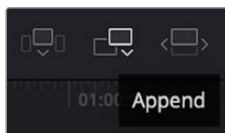

Click on the append icon to quickly add clips to the end of the last clip

#### To append a clip:

- 1 Double click on a clip in the media pool to open it in the viewer.
- 2 Using the scratch trim tool, drag the in and out points to select the precise duration of your shot. You can also press the 'i' and 'o' keyboard shortcuts to set in and out points.



- 3 Now click the 'append' icon underneath the media pool.



Your first clip will be placed at the head of the timeline.

Repeat steps 1 to 3 to keep adding more clips and they will automatically append, ensuring there are no gaps in the timeline.

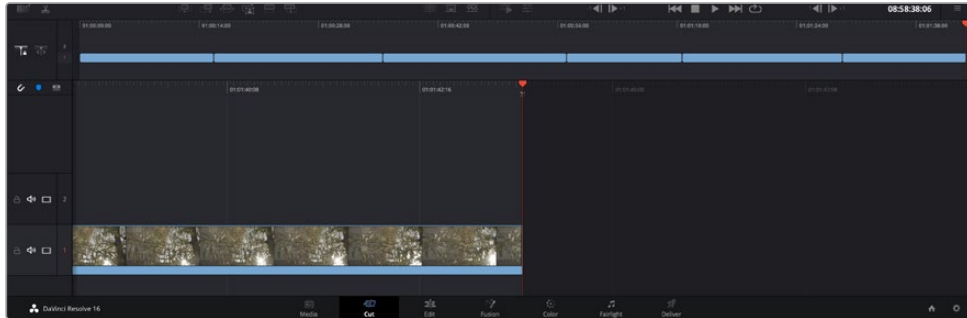

Appending clips ensures there are no gaps between them on the timeline

**TIP** You can speed up the process further by assigning a keyboard shortcut to the 'append' icon. For example, if you assign the 'P' key, you can set your in and out points using 'I' and 'O' then press 'P' to append the clip. Refer to the DaVinci Resolve manual for information on how to assign shortcut keys.

## Editing Clips on the Timeline

With clips added to the timeline, you have complete control to move them around and trim edits.

To trim an edit, hover the mouse over the start or end of a clip, then click and drag it left or right. For example, drag the end of the clip left or right to decrease or increase its duration. You might notice that all clips after that edit will shift on the timeline to accommodate the new adjustment. This is one way the 'cut' page helps to save you time.

You can even pick the clip up and drop it on a new video track in the large timeline without having to zoom in or out. This speeds up the edit process because it minimizes time navigating a long timeline.

After you have finished editing clips using the 'cut' page, you might want to add a title. The next section will show you how.

## Adding Titles

Placing a title on your timeline is easy and you have many options.

To see the different types of titles you can use, click on the 'titles' media tab at the top left corner of the user interface. In the selection window you will see all the different title generators you can use, from lower thirds, scrolls, to a standard text title. You can even add any of the Fusion titles which are animated titles that you can customize.

A good example is to add a standard title.

**To do this:**

- 1 Click on the 'text' title and drag it onto the timeline. It doesn't matter which timeline, but for greater accuracy we recommend using the detailed timeline. The title will automatically create a new video track for the title and will snap to the playhead.
- 2 Release the mouse and the title will appear on the new track. You can now move it or change its duration like you would another video clip.
- 3 To edit the title, click on the new title clip and a 'tools' icon will appear underneath the clip viewer. Click on the tools icon.

You will now see a row of tools you can use to modify the title clip. For example transform, crop, dynamic zoom and more. For this example, click on the 'title' tool.

- 4 Now click 'open inspector'.

This will open the inspector window where you can type in the title you want and edit the text settings, for example tracking, line spacing, font type, color and more.

You have a lot of options to customize the title exactly how you want it. We recommend playing with all the different settings to see how they can change the appearance and shape of your title.

## Working with Blackmagic RAW Files

Blackmagic RAW clips give you maximum flexibility in post production. This lets you make adjustments to clips, such as white balance and ISO settings, as if you were changing the original camera settings. Working with Blackmagic RAW also retains more tonal information within shadows and highlights, which is useful for recovering details, for example in blown out skies and dark areas of the picture.

It's worth shooting in Blackmagic RAW if you are after the highest possible quality, or for shots where there is an extreme variance between highlights and shadows and you may need to push and pull those regions as much as possible in the grade.

The speed and small file size of Blackmagic RAW means you don't need to make proxy files and playback is just like a standard video clip. This section of the manual describes the features of Blackmagic RAW and how to use Blackmagic RAW files in your DaVinci Resolve workflow.

**TIP** It is a good practice to adjust the Blackmagic RAW settings for your clips on the 'color' page before you start color grading.

### Clip Settings for Blackmagic RAW

When you first import Blackmagic RAW files, DaVinci Resolve will decode the camera data contained in the files using the ISO, white balance and tint settings used at the time of shooting. If you're happy with the look of these settings, you can start editing right away.

The great thing about shooting Blackmagic RAW is that you're not tied to these settings at all! The breadth of available post processing options when working with Blackmagic RAW files mean that you'll develop your own workflow over time. Experimenting with the 'clip' settings for each clip in the 'camera raw' tab will show you just how powerful and flexible working with Blackmagic RAW can be.

The 'color science' menu lets you choose whether to interpret your footage with generation 4 color science or generation 5 color science. URSA Mini Pro 12K is the first camera to use Blackmagic Design generation 5 color science. Files made on different cameras with generation 4 color science can be reinterpreted with generation 5 color science to match your shots from URSA Mini Pro 12K. Alternatively, if you are shooting mainly with cameras that create Blackmagic RAW files with generation 4 color science, you can mix in clips shot on URSA Mini Pro 12K with generation 5 color science by reverting them to generation 4 color science. This makes it easy to match shots filmed on cameras using different generations of Blackmagic color science.

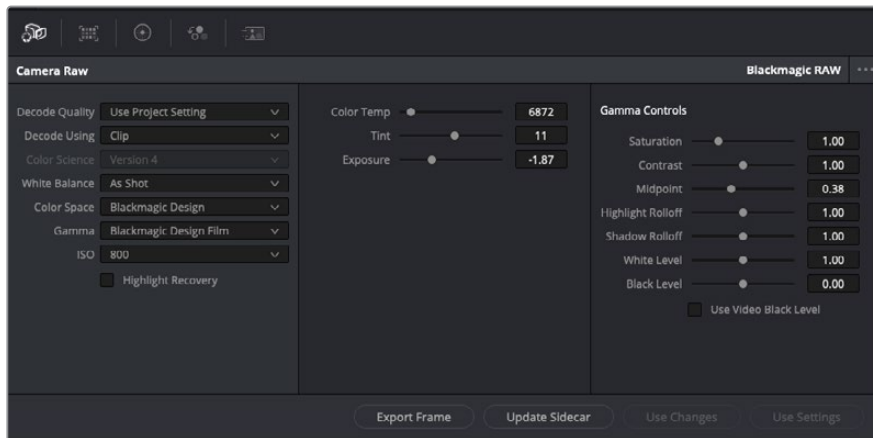

In the 'camera raw' tab, select 'clip' from the 'decode using' drop down menu to make adjustments to your clip's Blackmagic RAW settings

Once you have set DaVinci Resolve to enable clip settings for Blackmagic RAW, the clip settings and gamma controls are now adjustable. Adjusting these settings to optimize your clips can bring them close to a full primaries grade. This is especially powerful when using DaVinci Resolve's scopes which can help you neutralize and balance the clips ready for applying a look.

The following information contains descriptions for the clip and gamma controls.

### **ISO**

The ISO value can be changed by increasing or decreasing this setting. This setting is helpful if you need to set the clip to a brighter or darker starting point for optimization.

### **Highlight Recovery**

Check the box to reconstruct highlight information in clipped channels using information from non-clipped channels.

### **Color Temp**

Adjust the color temperature to warm or cool the image. This can be used to help neutralize the color balance in each image.

### **Tint**

Adjusting this setting will add green or magenta into the image to help balance the color.

### **Exposure**

Use this setting to refine the overall brightness of the image.

### **Saturation**

Saturation controls default at 1 and range from -1 for the minimum saturation to +4 for maximum saturation.

## Contrast

Defaulting at 1.0, drag the slider to the left for the least amount of contrast at 0 or to the right to increase the contrast up to 2.

## Midpoint

In Blackmagic Design Film, your middle gray value defaults to 0.38, or 38.4%. Drag the slider to the left to lower your midpoint or to the right to raise it to 100. When contrast is adjusted away from the default setting, you can modify your highlight and shadow rolloff.

## Highlight Rolloff

Adjust the highlights by dragging the slider to the left to lower the value to 0, or to the right to increase the highlights to 2. The default value is 1.

## Shadow Rolloff

Drag the slider to the left to lower your shadows to 0 or to the right to raise your shadows to 2.

## White Level

Adjust the white point of the gamma curve by dragging the slider from the highest value of 2 to the lowest value of 0. The default value is 1.

## Black Level

Raise the black point of the custom gamma curve by dragging the slider to the right from the lowest value of -1 to a maximum of 1. The default value is 0.

## Use Video Black Level

Check the box to set your black levels to video.

## Export Frame

Clicking the 'export frame' button lets you export a single frame from your Blackmagic RAW clip.

## Update Sidecar

Click this button to update the Blackmagic RAW sidecar file for the current clip.

Any changes you have made to your Blackmagic RAW clips will be identified by the gamma setting changing to Blackmagic Design Custom.

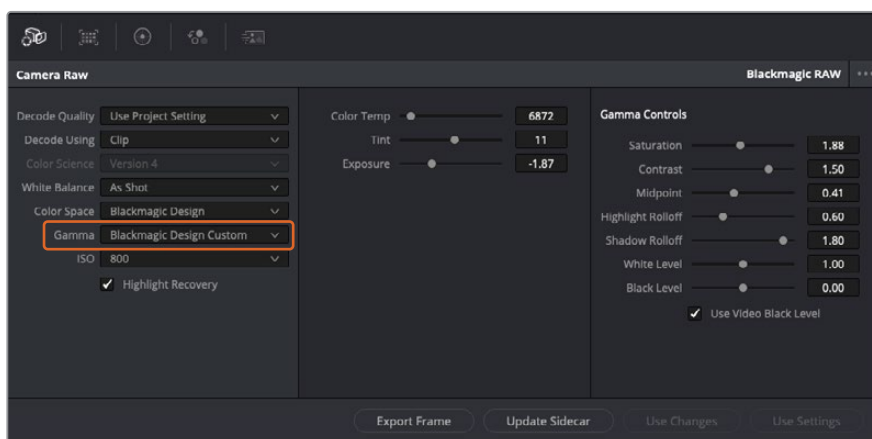

If you want to revert your clip to one of the default gamma options available, simply select it from the gamma dropdown menu.



**TIP** Gamma controls are disabled for footage shot with the 'video' dynamic range, but you have not lost your Blackmagic RAW data. Simply select Blackmagic Design Film or Blackmagic Design Extended Video from the dropdown gamma menu and make your adjustments.

### **Saving your Blackmagic RAW changes**

- 1 Adjust the gamma controls for your Blackmagic RAW clip.
- 2 Click the 'update sidecar' button.

A 'sidecar' file will now be created in the same folder as your .braw file. When another user imports the Blackmagic RAW files, the sidecar files will automatically be read by DaVinci Resolve. If you make additional adjustments, press 'update sidecar' again.

**TIP** To remove your sidecar file, you can simply delete it from its location on your media drive.

### **Project Settings for Blackmagic RAW**

If you need to make a setting change that is common to all the clips, for example a global change to the white balance or ISO setting, you can set the clips to use the project 'camera raw' settings and make global changes from there.

#### **To set project settings for Blackmagic RAW:**

- 1 Enter the project settings menu by clicking 'file,' and selecting 'project settings.'
- 2 In the 'Camera RAW' tab, you'll see a dropdown menu next to RAW profile. Click on the arrow to select Blackmagic RAW from the list.
- 3 Select 'project' in the 'Decode Using' dropdown menu.
- 4 Set the white balance setting to 'custom'.
- 5 Select 'Blackmagic Design Custom' from the dropdown gamma menu. Set the color space to 'Blackmagic Design'. This will also set the gamma setting to 'Blackmagic Design Film'.
- 6 Choose your resolution from the 'Decode Quality' menu. A lower resolution will give you better playback on limited systems. You also have the flexibility to change to full resolution later on before delivery for the highest quality output.

Now you can adjust the camera settings for your clips such as saturation, contrast and midpoint. This will affect all clips in your project that are set to decode using 'project'.

### **Color Correcting your Clips with the Color Page**

Now with your clips on the timeline and titles added, you can start color correcting using the 'color' page. The color page is extremely powerful and will define the overall look of your film, but for this example a good place to start is to neutralize all your clips so they are consistent. You can also return to the 'cut' or 'edit' page at any time if you want to make changes to your edit.

The color page lets you adjust the look of your edit and in many ways color correction is an art form in itself. You are really adding emotion to your work when you add color correction. It's an incredibly creative part of the workflow and very satisfying when you learn these skills and can

see your work come alive! This is usually the first step and is referred to as primary color correction, or adjusting the primaries. After primary color correction is done, you can then make secondary color correction adjustments which is where you can make extremely precise color adjustments of specific objects in your images. That is a lot of fun, but is normally done after primaries because it helps make the process more efficient and you will get a better result!

First click on the 'color' tab to open the color page.

You'll see the camera raw settings, color wheels, curves palettes and general color correction tools as well as the preview and nodes window. Don't feel overwhelmed by the vast array of features in front of you, they are all there to help you get the most amazing looking pictures. This getting started section will show the basics, but for more detailed information refer to the relevant sections in the manual. They will show you exactly what all the tools are for and how to use them in easy to follow steps. You'll learn the same techniques the professionals use in high end color correction facilities.

Generally, the first step for primary color correction is to optimize the levels for shadows, mid tones and highlights in your clips. In other words adjust the 'lift', 'gamma' and 'gain' settings. This will help get your pictures looking their brightest and best with a clean, balanced starting point from where you can begin grading the 'look' of your film. To optimize the levels, it's helpful to use the scopes.

## Using Scopes

Most colorists make creative color choices by focusing on the emotion and the look they want their program to have and then simply work using the monitor to achieve that look. You can look at everyday objects and how different types of light interact with them to generate ideas on what you can do with your images and a little practice.

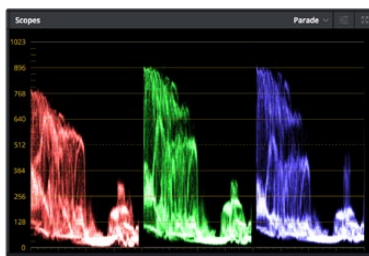

The parade scope helps you optimize highlights, mid tones and shadows

Another way to color grade is to use the built in scopes to help you balance shots. You can open a single video scope by clicking the 'scope' button, which is the second from the right on the palette toolbar. You can choose to display a waveform, parade, vectorscope and histogram. Using these scopes you can monitor your tonal balance, check the levels of your video to avoid crushing your blacks and clipping the highlights, plus monitor any color cast in your clips.

The 'color wheels' palette contains the 'lift', 'gamma' and 'gain' controls which will generally constitute your first adjustment. If you've previously had experience with color correction, these should resemble controls you've seen in other applications for doing color and contrast adjustments.



The 'lift', 'gamma', 'gain' and 'offset' color wheels give you total control over the color and tonal balance of your clips. To make a uniform adjustment to all colors for each tonal region, drag the dial underneath the color wheels back and forth

For more accurate control of each color using a mouse, you can change the color wheels to 'primaries bars' which let you adjust each color and luminance channel for the lift, gamma and gain controls separately. Simply select 'primaries bars' from the dropdown menu near the top right of the color wheels.

- **Adjusting the 'lift':** With your clip selected on the color timeline, click on the 'lift' dial underneath the first color wheel. Slide it back and forth and watch how it affects your image. You'll see the brightness of the dark regions of your picture increase and decrease.  
Set it to where you want the dark areas to look their best. If you decrease the lift too much, you'll lose details in the blacks and you can use the parade scope to help avoid this. The optimal position for blacks on the waveform is just above the bottom line of the parade scope.
- **Adjusting the 'gain':** Click on the 'gain' dial and slide it back and forth. This adjusts the highlights which are the brightest areas of your clip. The highlights are shown on the top section of the waveform on the parade scope. For a brightly lit shot, these are best positioned just below the top line of the waveform scope. If the highlights rise above the top line of the waveform scope, they will clip and you will lose details in the brightest regions of your image.
- **Adjusting the 'gamma':** Click on the 'gamma' dial underneath the color wheel and slide it back and forth. As you increase the gamma you'll see the brightness of the image increase. Notice the middle section of the waveform will also move as you adjust the gamma. This represents the mid tones of your clip. The optimal position for mid tones generally falls between 50 to 70% on the waveform scope. However, this can be subjective based on the look you are creating and the lighting conditions in the clip.

You can also use the curves palette to make primary color corrections. Simply click to create control points on the diagonal line inside the curve graph, and drag them up or down to adjust the master RGB contrast at different areas of image tonality. The optimum points to adjust are the bottom third, mid, and top third of the curve line.

There are many more ways of doing primary color correction in DaVinci Resolve.



The curves palette is another tool you can use to make primary color corrections, or enhance specific areas of your clip when using a power window

## Secondary Color Correction

If you want to adjust a specific part of your image then you need to use secondary corrections. The adjustments you have been doing up until now using the lift, gamma and gain adjustments affect the whole image at the same time and so they are called primary color corrections.

However, if you need to adjust specific parts of your image, say for example you wanted to improve the color in the grass in a scene, or you wanted to deepen the blue in a sky, then you can use secondary corrections. Secondary color corrections are where you select a part of the image and then adjust only that part. With nodes, you can stack multiple secondary corrections so you can keep working parts of your image until everything is just right! You can even use windows and tracking to allow the selections to follow movement in your images.

## Qualifying a Color

Often you'll find a specific color in your clip can be enhanced, for example grass by the side of a road, or the blue in a sky, or you may need to adjust color on a specific object to focus the audience's attention on it. You can easily do this by using the HSL qualifier tool.



Using the HSL qualifier to select colors in your image is helpful when you want to make areas of your image 'pop', to add contrast, or to help draw the audience's attention to certain areas of your shot

### To qualify a color:

- 1 Add a new serial node.
- 2 Open the 'qualifier' palette and make sure the 'selection range' picker tool is selected.
- 3 Click on the color in your clip you want to affect.
- 4 Usually you'll need to make some adjustments to soften the edges of your selection and limit the region to only the desired color. Click on the 'highlight' button above the viewer to see your selection.
- 5 Adjust the 'width' control in the 'hue' window to broaden or narrow your selection.

Experiment with the high, low and softness controls to see how to refine your selection. Now you can make corrections to your selected color using the color wheels or custom curves.

Sometimes your selection can spill into areas of the shot you don't want to affect. You can easily mask out the unwanted areas using a power window. Simply create a new window and shape it to select only the area of color you want. If your selected color moves in the shot, you can use the tracking feature to track your power window.

## Adding a Power Window

Power windows are an extremely effective secondary color correction tool that can be used to isolate specific regions of your clips. These regions don't have to be static, but can be tracked to move with a camera pan, tilt or rotation, plus the movement of the region itself.

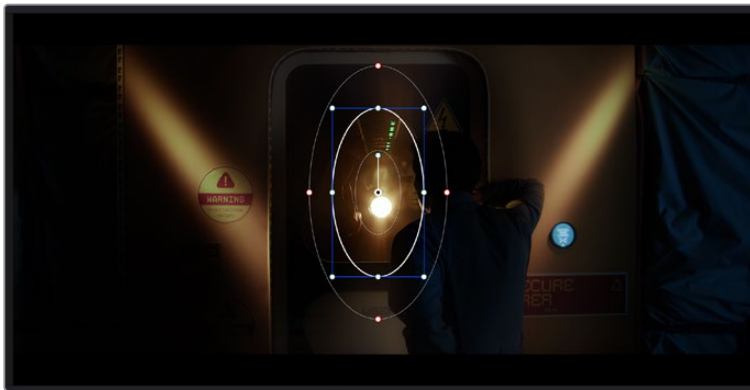

Use power windows to mask out areas you don't want to be affected by the HSL qualifier secondary adjustments

For example, you can track a window on a person in order to make color and contrast changes just to that person without affecting his or her surroundings. By making corrections like this you can influence the audience's attention on areas you want them to notice.

### To add a power window to your clip:

- 1 Add a new serial node.
- 2 Open the 'window' palette and select a window shape by clicking on a shape icon. Your selected window shape will appear on the node.
- 3 Resize the shape by clicking and dragging the blue points around the shape. The red points adjust the edge softness. You can position the shape by clicking the center point and moving it to the area you want to isolate. Rotate the window using the point connected to the center.

Now you can make color corrections to your image in just the area you want.

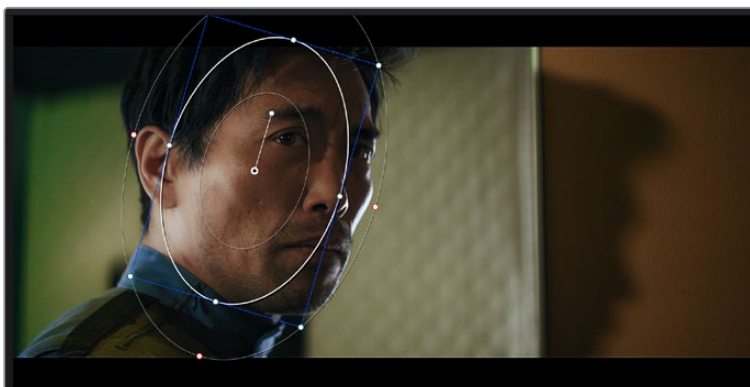

Power windows let you make secondary corrections to specific parts of your image

## Tracking a Window

The camera, object or area in your shot may be moving, so to make sure your window stays on your selected object or area, you can use DaVinci Resolve's powerful tracking feature. The tracker analyzes the pan, tilt, zoom and rotation of the camera or object in your clip so you can match your windows to that movement. If this isn't done, your correction can move off the selected target and call attention to itself, which you probably don't want.

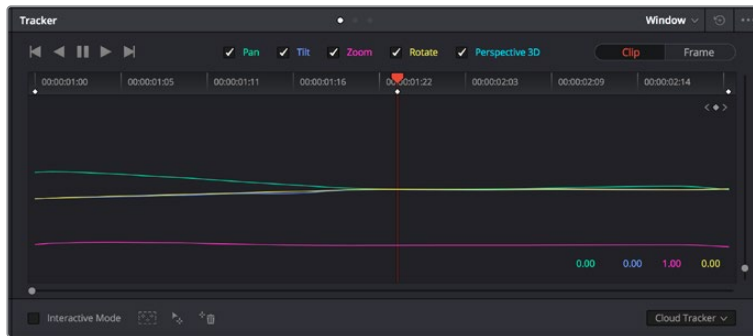

You can track objects or areas in your clip using the tracker feature so power windows can follow the action

### To track a window to a moving object:

- 1 Create a new serial node and add a power window.
- 2 Go to the start of your clip and position and size the window to highlight just the object or area you want.
- 3 Open the 'tracker' palette. Select the pan, tilt, zoom, rotate, and perspective 3D settings appropriate for the movement in your clip by checking or unchecking the relevant 'analyze' checkboxes.
- 4 Click on the 'forward' arrow to the left of the checkboxes. DaVinci Resolve will now apply a cluster of tracking points on your clip and then step through the frames to analyze the movement. When the tracking is done, your power window will follow the path of the movement in your clip.

Most of the time automatic tracking is successful, but scenes can be complex and sometimes an object can pass in front of your selected area, interrupting or affecting your track. This can be solved manually using the keyframe editor. Refer to the DaVinci Resolve manual to find out more.

## Using Plugins

While making secondary color corrections you can also add ResolveFX or OpenFX plugins to create fast, interesting looks and effects using the 'color' page, or imaginative transitions and effects on your clips on the 'edit' page. ResolveFX are installed with DaVinci Resolve, OFX plugins can be purchased and downloaded from third party suppliers.

After installing a set of OFX plugins, you can access them or ResolveFX plugins on the color page by opening the OpenFX inspector to the right of the 'node editor'. Once you create a new serial node, simply click the 'OpenFX' button to open the FX library and drag and drop a plugin onto the new node. If the plugin has editable settings, you can adjust these in the adjoining 'settings' panel.

In the 'edit' page you can add plugin filters, generators and transitions to clips by opening the 'OpenFX' panel in the 'effects library' and dragging your selected plugin onto the video clip or track above your clip on the timeline depending on the plugin requirements.

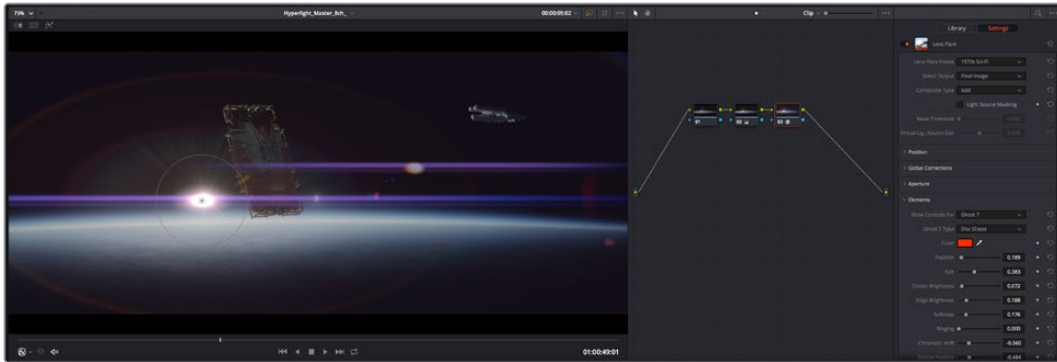

OFX plugins are a quick and easy way to create an imaginative and interesting look

## Mixing Your Audio

### Mixing Audio in the Edit Page

Once you have edited and color corrected your project, you can begin to mix your audio. DaVinci Resolve has a helpful set of features for editing, mixing and mastering audio for your project directly in the 'edit' page. For projects requiring more advanced audio tools, the Fairlight page provides you with a full audio post production environment. If you are already familiar with the edit page and want to move straight to Fairlight, skip this section and move onto the next.

### Adding Audio Tracks

If you are working in the edit page and want to mix a basic sound edit with lots of sound effects and music, you can easily add more audio tracks when you need them. This can be helpful when building your sound, and separating your audio elements into individual tracks, for example, dialogue, sound effects and music.

### To Add an Audio Track to the Edit Page

Right click next to the name of any audio track on your timeline and select 'add track' and choose from the options, including 'mono', 'stereo', and '5.1'. This will add the track to the bottom of the track list. Alternatively select 'add tracks' and select the position you would like the new track or multiple tracks placed.

Your new audio track will appear on the timeline.

**TIP** If you wish to change the type of track after creating it, right click next to the name of the track and select 'change track type to' and select the type of audio track you want, such as stereo, mono or 5.1.

### Adjusting Audio Levels in the Timeline

Each clip of audio in the timeline has a volume overlay that lets you set that clip's level by simply dragging it up or down with the pointer. This overlay corresponds to the Volume parameter in the Inspector.



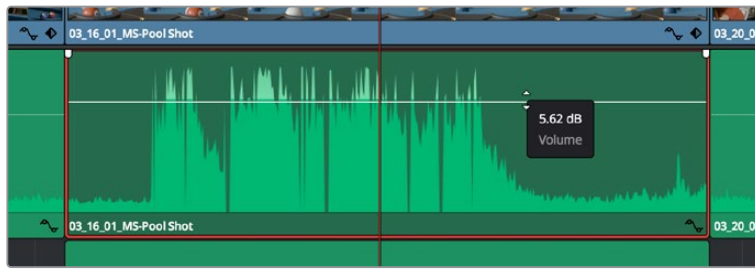

Dragging a volume overlay to adjust the clip level

For projects requiring more advanced audio tools, the Fairlight page provides you with a full audio post production environment.

## The Fairlight Page

The 'Fairlight' page in DaVinci Resolve is where you adjust your project audio. In single monitor mode, this page gives you an optimized look at the audio tracks of your project, with an expanded mixer and custom monitoring controls that make it easy to evaluate and adjust levels in order to create a smooth and harmonious mix. Don't feel overwhelmed by the vast array of features in front of you, they are all there to help you deliver the best audio quality for your project.

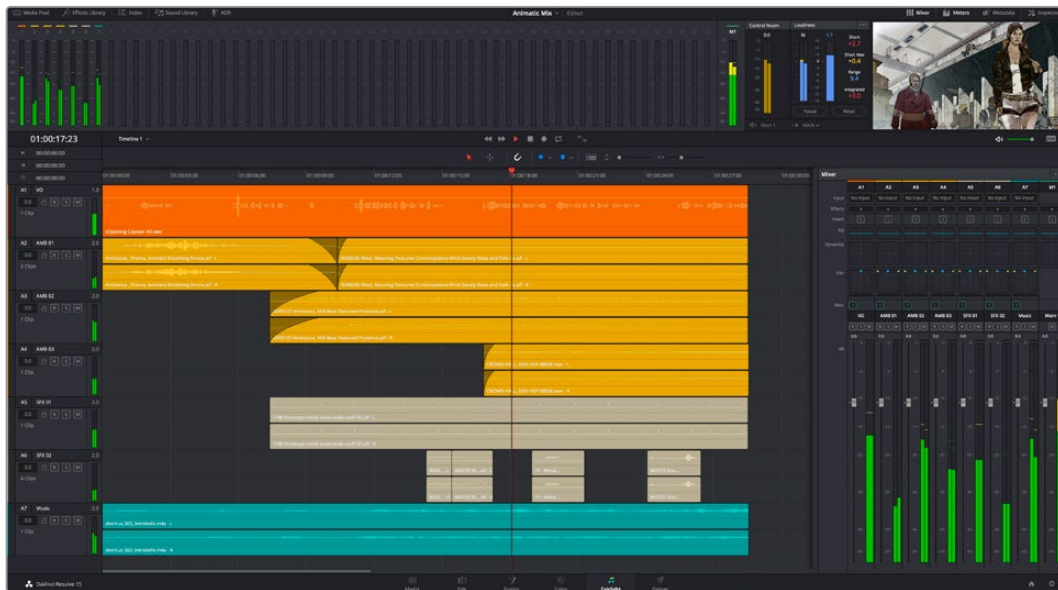

This guide provides a basic overview of the features on the Fairlight page, but to learn more about all the details for each feature, refer to the DaVinci Resolve manual. The DaVinci Resolve manual provides details on the purpose of each tool and describes how to use them in easy to follow steps.

## The Audio Timeline

- Track Header:** At the left of each track is a header area that displays the track number, track name, track color, audio channels, fader value and audio meters. The track header also contains different controls for locking and unlocking tracks, plus solo and muting controls. These controls can help to keep your tracks organized, and let you preview individual tracks one at a time.



- **Tracks:** Each track on the Fairlight page is divided into lanes, which show each individual channel of clip audio for editing and mixing. The edit page hides these individual audio channels, displaying only a single clip in the timeline to make it easier to edit multi channel sources without needing to manage a huge number of tracks.

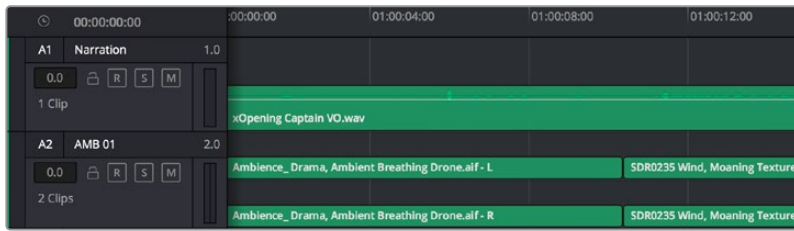

The track header on track A1 indicates a mono track with a single lane for mono audio, and the A2 track header indicates a stereo track with two lanes to accommodate stereo audio

## What is a Bus?

A bus is essentially a destination channel to which you can route multiple audio tracks from the timeline, so that they are mixed together into a single signal that can be controlled via a single channel strip.

- **Main Bus:** 'Main busses' are typically the primary output of a program and each new project you create starts out with a single 'main bus', to which all tracks are routed by default. The 'main bus' combines all of the tracks in the timeline into one signal so that you can adjust the overall level of the audio mix once you have adjusted the level of each individual track.
- **Sub Bus:** 'Sub busses' allow you to combine multiple tracks of audio that belong to the same category such as dialogue, music or effects so that everything in that category can be mixed as a single audio signal. For example, if you have five dialogue tracks, you can route the output of all five dialogue tracks to a 'submix bus', and the level of all dialogue can then be mixed with a single set of controls. This submix can be rendered separately or sent to the main bus for render.

## The Mixer

Each audio track in your timeline corresponds to an individual channel strip in the Mixer, and by default there's a single strip on the right for the 'main bus' labeled 'M1'. Additional channel strips will appear on the right hand side with a set of controls for each additional 'main' and 'submix bus' you create. A set of graphical controls allows you to assign track channels to output channels, adjust EQ and dynamics, set levels and record automation, pan stereo and surround audio, and mute and solo tracks.

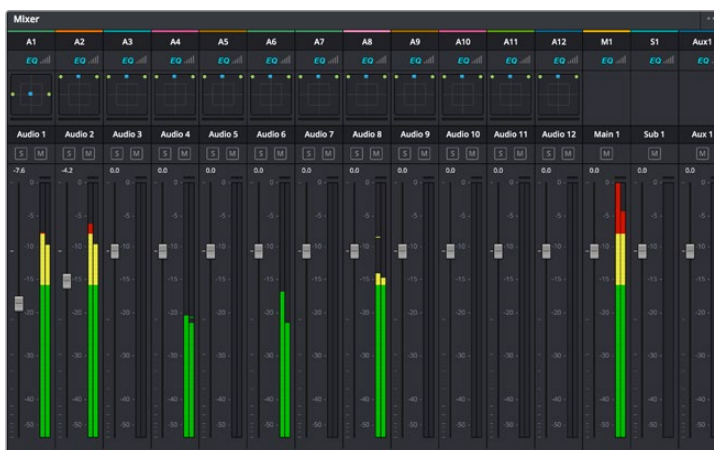

The audio mixer, with channel strips corresponding to the tracks in the timeline

## Using the Equalizer to Enhance your Audio

After adjusting the audio levels of your audio clips in your project, you may find that the audio needs further finessing. In some cases you may find that the dialogue, music and sound effects are competing for the same frequency on the audio spectrum, making your audio too busy and unclear. This is where using EQ can help, as it allows you to specify the parts of the audio spectrum that each track occupies. You can also use an equalizer to help remove unwanted elements from your audio by isolating and reducing the level on particular frequencies that contain low rumbles, hums, wind noise and hiss, or simply to improve the overall quality of your sound so it is more pleasing to listen to.

DaVinci Resolve provides EQ filters that can be applied at a clip level to each individual clip or at the track level to affect entire tracks. Each audio clip in the timeline has a four band equalizer in the inspector panel, and each track has a 6 band parametric equalizer in the mixer panel. The graphical and numeric controls for boosting or attenuating different ranges of frequencies, and different filter types allow you to define the shape of the EQ curve.



The four band equalizer can be applied to every clip in the timeline

Outer bands let you make band filter adjustments using hi-shelf, lo-shelf, hi-pass and lo-pass filters. A pass filter affects all the frequencies above or below a particular frequency, by removing those frequencies completely from the signal. For example, a high pass filter will allow the high frequencies to pass through the filter while cutting the low frequencies. Any frequencies outside the cutoff frequency are cut gradually in a downward sloping curve.

A shelf filter is less aggressive, and is useful when you want to shape the overall top end or low end of the signal without completely removing those frequencies. The shelf filter boosts or cuts the target frequency and every frequency either above or below it evenly, depending on whether you use a high shelf or low shelf.

The middle sets of band controls let you make a wide variety of equalization adjustments, and can be switched between lo-shelf, bell, notch, and hi-shelf filtering options.

- **Bell:** Bell filters boost or cut frequencies around a given center point of the bell curve, and as the name suggests the shape of the curve is like a bell.
- **Notch:** Notch filters allow you to specifically target a very narrow range of frequencies. For example, removing a mains hum at 50 or 60Hz.
- **Lo-Shelf:** Low shelf filters boost or cut the target frequency at the low end, and every frequency below it
- **Hi-Shelf:** High shelf filters boost or cut the target frequency at the high end, and every frequency above it

### To add EQ to an individual clip:

- 1 Select the clip in the timeline that you want to add the EQ filter to.
- 2 Click on the inspector and then click the 'clip equalizer' enable button.

### To add EQ to a track:

- 1 Double click in the EQ section for one of your tracks in the mixer to open the equalizer for that track.
- 2 Select the band filter type from the dropdown menu for the band you want to adjust.



The EQ section in the mixer panel indicating an EQ curve has been applied to track one



The 6 Band parametric equalizer that can be applied to every track

Once you have added EQ to your clip or track, you can adjust the EQ for each band. Note that controls may vary depending on which band filter type is selected.

### To adjust the EQ for a band filter:

- 1 Select the band filter type from the dropdown menu for the band you want to adjust.
- 2 Adjust the 'frequency' value to select the center frequency of the EQ adjustment.
- 3 Adjust the 'gain' value to boost or attenuate the frequencies governed by that band.
- 4 Use the 'Q factor' value to adjust the width of affected frequencies.

Use the reset button to reset all controls in the EQ window to their defaults.

Fairlight has many controls you can use to improve the quality of each audio track. You can add more tracks and arrange buses to organize them, plus add effects like delay or reverb, and generally perfect your audio mix.

## Adding VFX and Compositing on the Fusion Page

Now that you have completed your edit, you can open the Fusion page to add 2D or 3D visual effects and motion graphics right within DaVinci Resolve. Unlike layer based compositing software, Fusion uses nodes, giving you the freedom to build complex effects while routing image data in any direction. The nodes window clearly shows every tool used along the way. If you have experienced the node workflow in the color page, this will feel familiar to you.

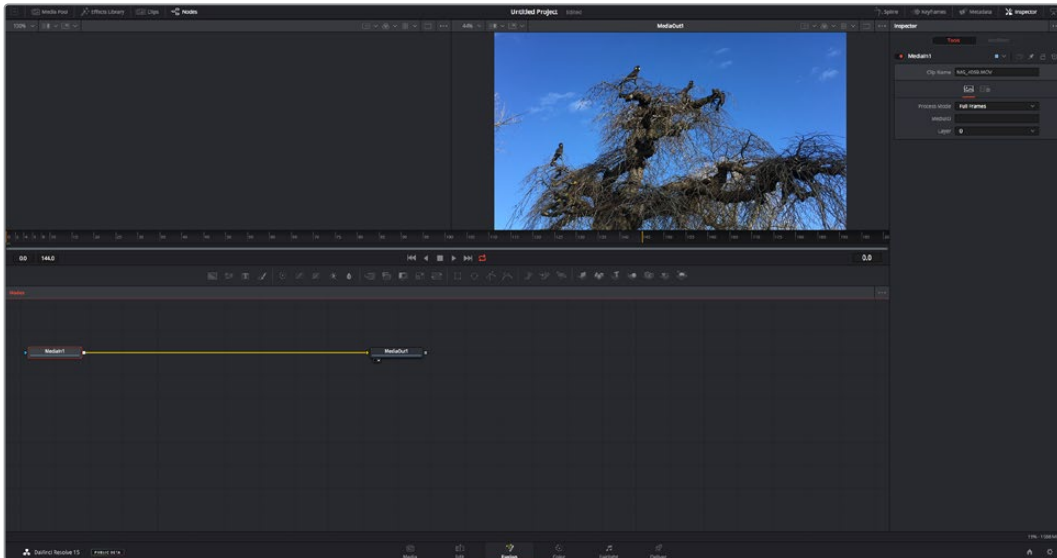

### The Fusion Page

The Fusion page features 2 viewer windows across the top with transport controls to view your media, an inspector window to the right to access tool settings, and a nodes window at the bottom where you build your composition. While the viewers and transport controls are always visible, clicking on the icons on the interface toolbar at the very top of the display will let you show or hide the nodes and inspector windows, or reveal or hide additional windows including the effects library and editors for spline and keyframes.

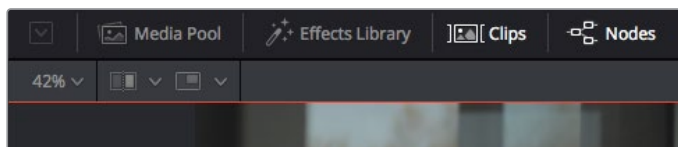

- **Media Pool:** The media pool functions the same way as it appears in the edit page. Simply drag additional media from your bins directly to your composition.
- **Effects Library:** The effects library is where you will find your Fusion tools and templates sorted into categories including particle, tracking, filters and generators. You can either click on the tool or drag it to the nodes area to add it to your composition. The media pool and effects library take up the same screen area, so you can swap between the two to keep your viewers as large as possible.
- **Clips:** Clicking the clips tab will reveal or hide thumbnails representing clips on your timeline. The thumbnails are located underneath the nodes editor, letting you instantly navigate to other clips.

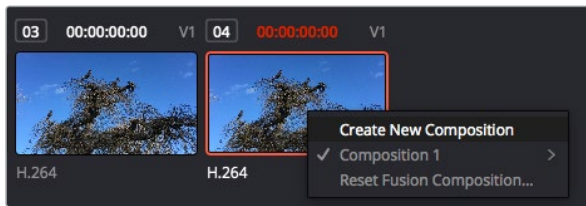

Create a new version of your composition by right clicking on a thumbnail and selecting 'create new composition'.

- **Viewers:** The viewers are always visible and let you see the different views of your composition, for example an overall 3D perspective via the merge 3D node, a camera output, or your final render output. These viewers also let you see how your changes are affecting a specific element.

You can choose which nodes to view by clicking on a node and typing '1' for the left viewer or '2' for the right viewer. White button icons appear beneath the node to let you know which viewer it is assigned to. If you're using external video monitoring, there will be a third button available to route your media to your external video monitor.

**TIP** You can also assign a node to a viewer by dragging the node into the viewer itself.

The transport controls underneath the viewers let you skip to the start or end of the clip, play forward or reverse, or stop playback. The time ruler displays the entire range of a clip, with yellow marks indicating the in and out points.

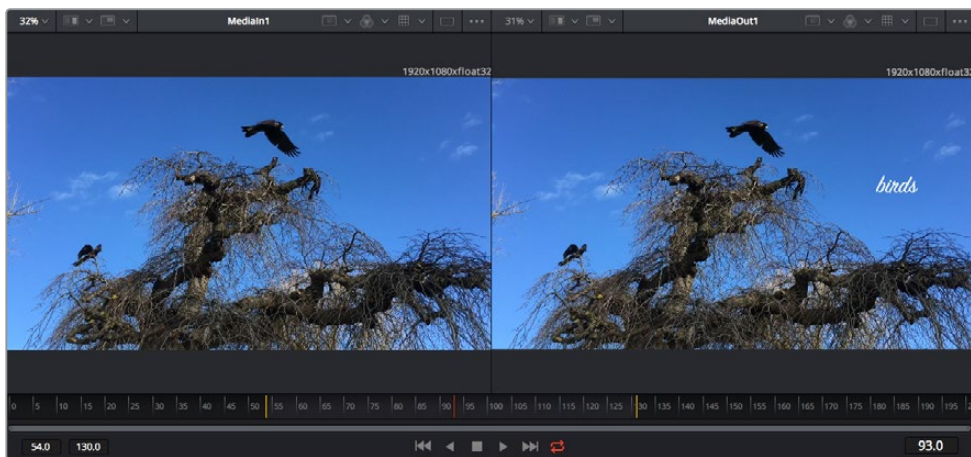

The yellow marks on the time ruler indicate your clip's in and out points on your timeline. If you are using a Fusion clip or compound clip, the time ruler will only show you the duration of the clip as it appears on the timeline, without handles.

- **Nodes:** The nodes window is the heart of the Fusion page where you build your node tree by connecting tools together from one node's output to another node's input. This area will change size depending on which editors are open, for example the spline or keyframes editor. A toolbar at the top of the nodes area features the most commonly used tools for fast access.
- **Spline:** When the spline editor is open, it will appear to the right of the nodes window. This editor lets you make precise adjustments to each node, such as smoothing the animation between two keyframes using bezier curves.

- **Keyframes:** Keyframes for each tool can be added, removed or modified using the keyframes editor. This also appears to the right of the nodes viewer.
- **Metadata:** The metadata window will show you metadata available for the active clip, including the codec, frame rate and timecode.
- **Inspector:** The inspector in the top right corner displays all settings and modifiers available for one or more selected nodes. Additional tab options will appear to provide quick access to other settings for nodes sorted by category.

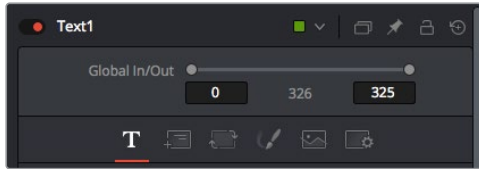

The text inspector contains additional tabs for text, layout, transform, shading, image and settings.

## Getting Started with Fusion

To get started with Fusion, simply position your playhead over any clip on your timeline and click on the 'Fusion' tab to open the Fusion page.

On the Fusion page, your clip is immediately available in a media input node labelled 'MediaIn'. Every composition will begin with a 'mediain' and a 'mediaout' node. This mediain node represents the top most clip of your timeline at the playhead, and ignores any clips underneath. Any adjustments you've applied to the clip on the edit page, such as transform tools and cropping changes, are also included.

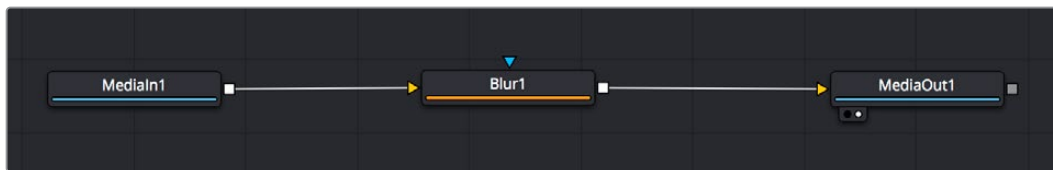

The media output node, named 'MediaOut', is the node that sends the output back to your timeline on DaVinci Resolve's edit page.

**TIP** ResolveFX or OFX plug-ins applied to clips in the edit page are not applied in the Fusion page. This is because Fusion effects occur prior to color correction and OFX/ResolveFX processing. If you want OFX applied before Fusion effects, right click the clip in the edit page and select 'new fusion clip' before clicking on the Fusion page.

## Understanding Nodes

It can be helpful to think of each node as a visual icon representing a single tool or effect. Nodes are connected to other nodes to build the overall composition, much like ingredients in a cake. It's important to understand the inputs and outputs of each node as this will help you navigate the flow of your composition while building detailed visual effects.

Some tools have multiple inputs and outputs you can connect to other nodes. The merge node, for example, lets you attach a foreground input, background input, and a mask input for mattes or keys.

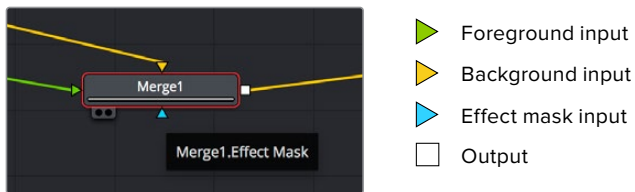

Multiple outputs on nodes means a single node can connect to many different nodes in your composition, so you don't have to duplicate clips as you would in layer based software. Arrows on the line between connected nodes are a great visual indicator to show you which direction the image data is flowing.

### Adding Nodes to the Node Editor

Adding effects is as simple as placing nodes on the line between the 'mediain' and 'mediaout' nodes.

There are a few ways you can do this. You can hold down the shift button and drop a node between two nodes, or click on the node you want to attach an effect to and select the tool you want to add. The new node will automatically connect to the tool selected. You can also add a node anywhere on the node window and manually connect nodes by dragging the output of one to the input on another.

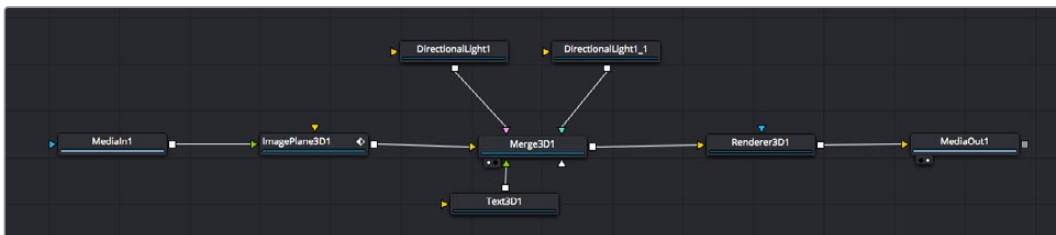

The most commonly used tool is the 2D or 3D merge node. This node is like a central hub that combines tools on the node editor into a single output.

The merge node has controls for how the inputs are managed, including settings for size, position, and blend. These settings are all accessible in the inspector panel when the merge node is selected.

The toolbar above the node panel contains the most commonly used tools as icons that you can either click on to add the node, or drag the tool to the node panel. If you want to see all the complete tools available, click on the 'effects library' in the top left corner and expand the 'tools' option. Here you'll find all the tools sorted by category, as well as a set of pre-built 'templates' you can use, for example lens flares, shaders and backgrounds.

**TIP** Once you're familiar with the tool names, you can hold down 'shift' and press 'spacebar' on your keyboard and a 'select tools' menu will appear. As you type the tool name, the menu will suggest the relevant tool. This is a very fast way to select the tool you want.



## Adjusting Nodes Using the Inspector Panel

Adjust your node settings using the inspector panel. Simply click on the node you want to modify and the panel will update to display its settings and controls.

With Fusion, you don't have to be viewing the node you're editing, as you can modify one node while viewing another in your composition. For example, you can modify the size and center position of a 'text+' node while the merge node is in the viewer, letting you view the text relative to the background.



Selected nodes appear with a red border. Here the inspector panel is displaying the layout tab controls for the text node.

There are different parameters and settings you can adjust for every node depending on its task, from sizing and center positions to changing the number of particles in an emitter node. Setting keyframes and changing the settings over time will animate the effect.

## Working with Keyframes

In the inspector window, set a keyframe by right clicking on a setting and choosing 'animate' from the contextual menu. The keyframe icon to the right of the setting will turn red. This means keyframes are now active and any changes you make will be applied to the current frame only. When two or more keyframes are created by changing the setting parameters on a different frame, a transition is interpolated between them. Arrows on each side of the keyframe icon let you move the playhead to those exact positions on the timeline.

The splines panel gives you further control over keyframe animation. You can select keyframes, such as the first and last, and smooth the animation between them into a bezier curve by typing 'shift' + 's', or right clicking on a keyframe and selecting 'smooth'.



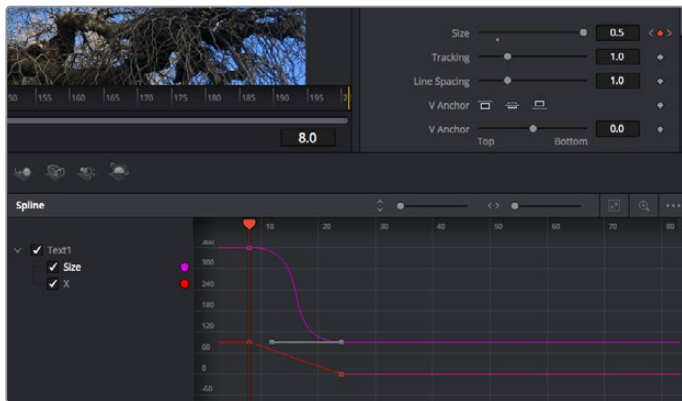

Here, the 'size' keyframe animation has been smoothed into a bezier curve. You can click the bezier handles to shorten or lengthen the curve, or the keyframe square icons to move the keyframe location.

## Using the Motion Tracker and Adding Text

To get a better idea of how to use Fusion, we have included the following examples to show how to use the tracker tool to track an element in a clip, plus add text and attach it to the element using the tracking data.

The 'tracker' tool tracks pixels over time on the x & y axis, and generates data you can use to attach other elements. This is great for when you want to match the position of text to a moving object, such as a car driving along the road, or a bird as it flies across frame.

- 1 In the 'effects library', select the 'tracking' tool and drag it to the line between the 'mediain' and the 'mediaout' nodes. Now click the tracker node to reveal its properties in the inspector.
- 2 Type '1' on your keyboard to see the 'tracker' node on the left viewer. The clip will appear in the viewer together with the tracker at its default position. Hover your mouse pointer over the tracker to reveal the tracker handle. Click on the tracker handle at the top left corner and drag the tracker to an area of interest on your clip. High contrast areas work well, for example the badge on the hood of a car. The tracker will magnify the image area for extra precision.
- 3 In the inspector window, click on the 'track forward' button to start tracking. A notification window will appear when the tracking is done. Click OK.

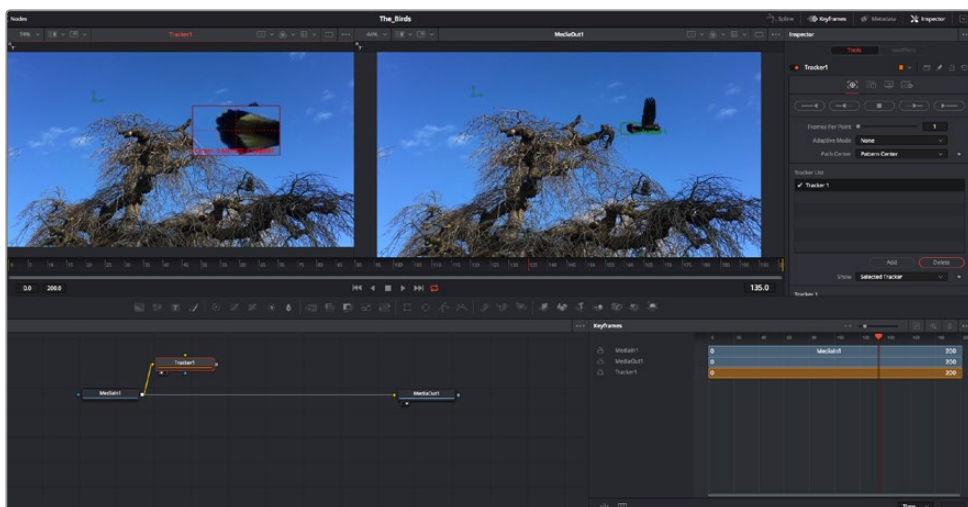

Tracking options in the inspector panel include track reverse from last frame or current frame, stop track or track forward from current frame or first frame.

**TIP** Track reverse or forward from current frame is great for situations where your area of interest disappears during the render range, such as a car or bird moving out of frame. This lets you track only the relevant footage.

Now you can take that tracking data and apply the motion path to a text tool.

- Click on the 'text+' node icon from the toolbar of commonly used nodes and drag it to the node panel near the 'tracker' node. Connect the 'text' output square to the green foreground input on the 'tracker'.

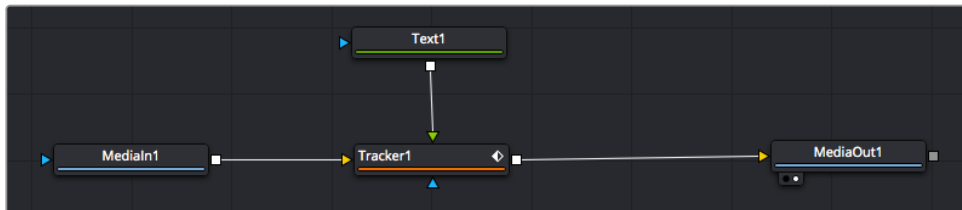

- Click on the 'tracker' node and type '1' so you can see the merged results on your left hand viewer. In the 'tracker' inspector panel, click on the 'operations' tab. You can see the tab's name by hovering the mouse pointer over it. Click the dropdown menu next to operation and select 'match move'.
- Click the 'text' node to reveal the properties in the inspector. Type your text into the text box and change the font, color and size to suit your composition.

This will apply the tracking position data from your tracker to your text. If you want to change the text offset, click on the 'trackers' tab back in the inspector panel and use the x and y offset scroll wheels to modify the position.



Scroll wheels at the bottom of the tracker inspector panel let you adjust the offset position for the text.

Now you can play back your composition and see your text attached to the object you have tracked!

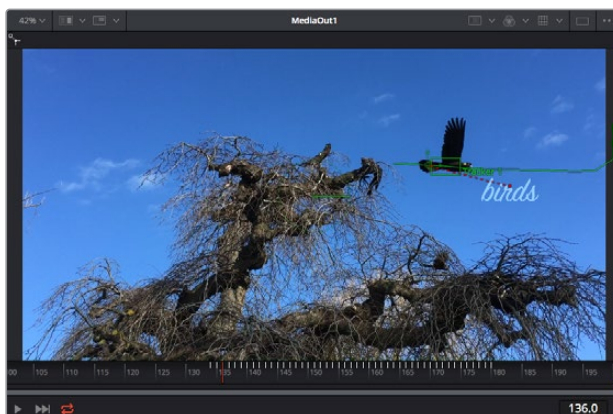

The green square is the tracker's current position along the green path, and the red dashed line is the offset position used to animate the text.

For some shots you might want to remove track points after tracking, such as when the object you are tracking disappears off the screen. The keyframe editor makes this a very simple process.

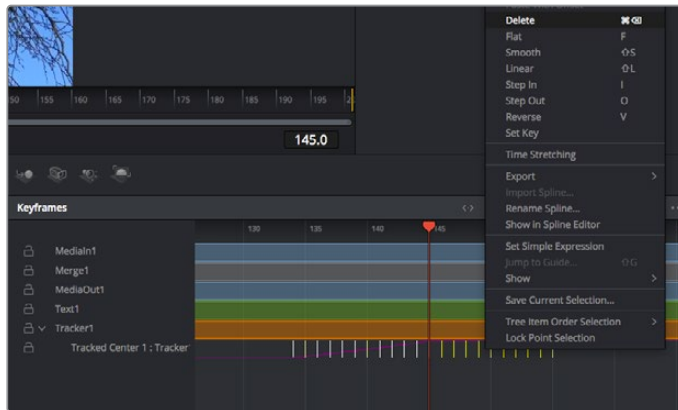

- 7 Click on the keyframes tab above the inspector to open the keyframes editor. Any nodes with keyframes applied will have a small arrow next to the node label, and only the parameter with keyframes added will appear in the list below. Click on the magnify icon and drag a box around the area you want to edit. This will zoom into that area so you can see the keyframes easier.
- 8 Move the playhead to the location of the last keyframe you want. Now select the keyframes you wish to remove by drawing a box around them with your mouse. The keyframes will highlight yellow. Right click and choose delete from the menu.

**TIP** If your effects are particularly system intensive, right clicking on the transport controls area will give you viewer options, including proxy playback, helping you get the most out of your system while you build your composition. Refer to the DaVinci Resolve manual for further detail on all the playback options.

You have now completed your first composition animating text to match a movement in your footage!

If you want to track an area of the image that contains a flat surface you want to enhance or replace, you can use the planar tracker. Tracking 2D planes can be helpful for changing labels and signs in a moving image, or even adding an image to a monitor or TV in your shot.

For more information about the planar tracker and the many powerful tools in the DaVinci Resolve Fusion page, see the DaVinci Resolve manual.

**TIP** As you build visual effects in the Fusion page, it's worth noting if the effect you are building is a 2D effect, or a 3D effect, as this will determine which merge tool is used. You may discover yourself frequently combining 2D and 3D effects in the one composite. In this scenario, it's helpful to remember that any visual effect using the 3D space needs to be rendered as a 2D image before it can be merged into a 2D composite.

We believe you will have lots of fun with Fusion and exploring Fusion’s visual effects with the power of DaVinci Resolve’s edit, color, and Fairlight pages. With all these tools at your finger tips, DaVinci Resolve is incredibly powerful and there is really no limit to what you can create!

## Mastering Your Edit

Now you’ve edited, graded, added vfx and mixed your audio, you’ll want to share it with others. You can use the Quick Export button, or menu selection, to output the contents of the Timeline as a self contained file in one of a variety of different formats, or use the additional features of the ‘deliver’ page.



The ‘deliver’ page is where you export your edit. You can select from many different video formats and codecs

## Quick Export

You can choose File > Quick Export to use one of a variety of export presets to export your program from any page of DaVinci Resolve. You can even use quick export to export and upload your program to one of the supported video sharing services, including YouTube, Vimeo, and Frame.io.

### To use Quick Export:

- 1 In the ‘edit’, ‘fusion’, or ‘color’ page, optionally set in and out points in the timeline to choose a range of the current program to export. If no timeline in or out points have been set, the entire timeline will be exported.

Choose File > Quick Export.

- 2 Select a preset to use from the top row of icons in the quick export dialog, and click ‘export’.
- 3 Choose a directory location and enter a file name using the export dialog, then click ‘save’. A progress bar dialog appears to let you know how long the export will take.

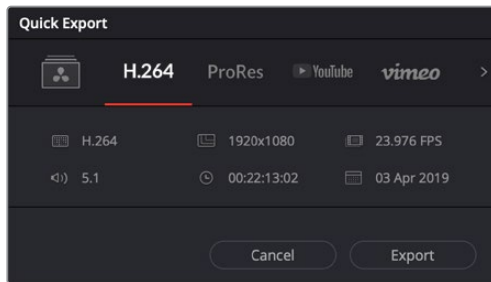

The quick export dialog

## The Deliver Page

This page lets you select the range of clips you want to export, plus the format, codec and resolution you want. You can export in many types of formats such as QuickTime, AVI, MXF and DPX using codecs such as 8-bit or 10-bit uncompressed RGB/YUV, ProRes, DNxHD, H.264 and more.

### To export a single clip of your edit:

- 1 Click on the 'deliver' tab to open the deliver page.
- 2 Go to the 'render settings' window on the top left of the page. Choose from a number of export presets, for example YouTube, Vimeo and audio presets, or you can set your own export settings manually by leaving it set to the default 'custom' preset and entering your own parameters. For this example, select YouTube, then click on the arrow next to the preset and select the 1080p video format.  
  
The frame rate will be locked to your project frame rate setting.
- 3 Underneath the presets you will see the timeline filename and the target location for your exported video. Click the 'browse' button and choose the location where you want to save your exported file and then select 'single clip' from the render option.
- 4 Immediately above the timeline, you'll see an options box with 'entire timeline' selected. This will export the entire timeline, however you can select a range of the timeline if you want to. Simply choose 'in/out range' and then use the 'i' and 'o' hot key shortcuts to choose the in and out points in your timeline.
- 5 Go to the bottom of the 'render settings' and click on the 'add to render queue' button.

Your render settings will be added to the render queue on the right side of the page. Now all you have to do is click 'start render' and monitor the progress of your render in the render queue.

When your render is complete you can open the folder location, double click on your new rendered clip and watch your finished edit.

Now that you have a basic knowledge of how to edit, color, mix audio and add visual effects, we recommend experimenting with DaVinci Resolve. Refer to the DaVinci Resolve manual for more details on how each feature can help you make the most of your project!

# Understanding Studio Camera Control

Blackmagic URSA Mini can be used as a studio camera and controlled from an ATEM switcher using the Camera Control feature in ATEM Software Control. This lets you add a camera with large sensor picture quality and amazing dynamic range to your broadcast studio and control it just as you would any studio camera.



ATEM Camera Control

Clicking on the camera button opens the camera control feature. Settings such as iris, gain, focus and zoom control are easily adjusted using compatible lenses, plus you can color balance cameras and create unique looks using the DaVinci Resolve primary color corrector. It's important to note that the DaVinci Resolve primary color corrector and 'detail sharpening' features of ATEM Camera Control are not available for URSA Mini Pro 12K.

The ATEM switcher control works by broadcasting camera control packets via all the non down converted SDI outputs of an ATEM switcher. So this means you can connect an SDI output of an ATEM switcher to URSA Mini's 12G SDI input, your camera will detect the control packets in the SDI link and allow you to control features in the camera itself.

## Connecting your URSA Mini

- 1 Connect your Blackmagic URSA Mini's 12G-SDI Out to any SDI In on the ATEM switcher.
- 2 Connect any one of the ATEM switcher's SDI outputs, except down converted or multi view outputs, to your URSA Mini's 12G-SDI input. Camera control signals are not sent via the multi view and down converted SDI outputs.
- 3 On your URSA Mini, navigate to 'ATEM Camera ID' in the 'setup' menu and set your camera's ATEM ID to match the switcher input. For example, if URSA Mini 1 is connected to Cam 1 on the ATEM switcher, the camera number must also be set to 1. This ensures tally is sent to the correct camera.
- 4 In the 'setup' menu select your 'reference source'. Unless you have a genlock signal being sent to all of your cameras and your switcher, we recommend setting 'reference source' to 'program' when attached to ATEM.

- 5 Navigate to the 'monitor' menu and ensure that you have selected 'clean feed' for 'main SDI' to ensure that you don't see overlays or the focus box on the SDI output to the ATEM switcher.

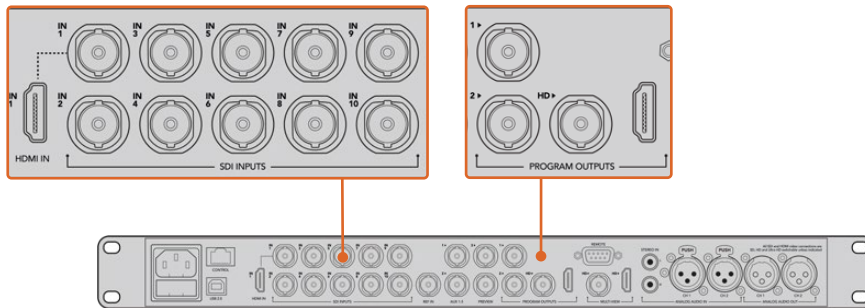

Connect your URSA Mini to any of the ATEM switcher's SDI inputs

## Using Camera Control

Launch ATEM Software Control and click on the camera button located at the bottom of the software window. You'll see a row of labeled camera controllers containing tools to adjust and refine each camera's image. The controllers are easy to use. Simply click the buttons using your mouse, or click and drag to adjust.

### Camera Control Selection

The button row at the top of the camera control page lets you select the camera number you would like to control. If you have more cameras that fit onto the window size, or you are running the color corrector window, then you can use these buttons to select between which camera you would like to control. If you are using an Aux output for monitoring your camera control, pushing these buttons to change the camera to control will also send that camera's video output to the Aux output setup in the switcher preferences.



Click on the settings icon to select the Aux output for camera control

### Channel Status

The channel status at the top of each camera controller displays the camera label, On Air indicator and lock button. Press the lock button to lock all the controls for a specific camera. When on air, the channel status illuminates red and displays the On Air alert.



Each camera controller displays the channel status so you know which camera is on air. Use the color wheels to adjust each YRGB channel's lift, gamma and gain settings



## Color Wheel

The color wheel is a powerful feature of the DaVinci Resolve color corrector and used to make color adjustments to each YRGB channel's lift, gamma and gain settings. You can select which setting to adjust by clicking on the three selection buttons above the color wheel.

## Master Wheel

Use the master wheel below the color wheel to make contrast adjustments to all YRGB channels at once, or luminance only for each lift, gamma or gain setting.

## Reset Buttons

The reset button near the top right of each camera controller lets you easily choose color correction settings to reset, copy or paste. Each color wheel also has its own reset button. Press to restore a setting to its default state, or copy/paste a setting. Locked controllers are not affected by the Paste feature.

The master reset button on the top right corner of the color corrector panel lets you reset lift, gamma and gain color wheels plus Contrast, Hue, Saturation and Lum Mix settings. You can paste color correction settings to camera controllers individually, or all cameras at once for a unified look. Iris, focus, coarse and pedestal settings are not affected by the Paste feature. When applying Paste to all, a warning message will appear asking you to confirm your action. This is so you don't accidentally paste new settings to any unlocked cameras that are currently on air.

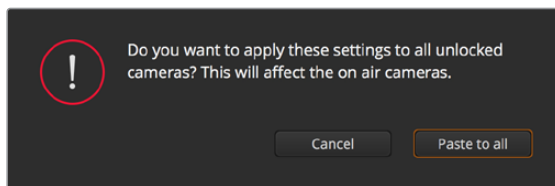

When applying Paste to all, a warning message will appear asking you to confirm your action. This is so you don't accidentally paste new settings to any unlocked cameras that are currently on air

## Iris/Pedestal Control

The iris/pedestal control is located within the cross hairs of each camera controller. The control illuminates red when its camera is on air.

To open or close the iris, drag the control up or down. Holding the shift key allows only iris adjustments.

**NOTE** When connected to ATEM ensure that you have Auto Exposure switched off. If you require Iris, zoom or focus control ensure that you have a lens that can be controlled electronically by the camera.

If you're using a B4 or PL lens connected via the broadcast 12 pin connector on URSA Mini, make sure the lens iris switch on the handgrip is set to 'A' or 'auto'.



To darken or lift the pedestal, drag the control left or right. Holding the command key on a Mac, or the Control key on Windows, allows only pedestal adjustments.

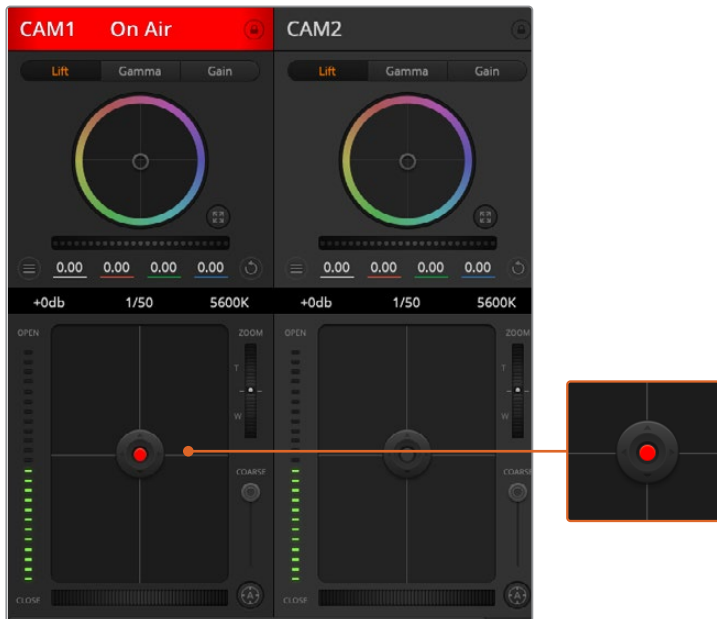

The iris/pedestal control illuminates red when its respective camera is on air

## Zoom Control

When using compatible lenses with an electronic zoom feature, you can zoom your lens in and out using the zoom control. The controller works just like the zoom rocker on a lens, with telephoto on one end, and wide angle on the other. Click on the zoom control, located above the coarse slider, and drag up to zoom in, or drag down to zoom out.

If your lens does not have active lens control or your camera does not support zoom control via the SDI camera control protocol then these settings will have no effect. For example, EF lenses do not have built in servos that can zoom the lens electronically so will not be zoomable with ATEM camera control.

**NOTE** Analogue B4 lenses do not support ATEM zoom control. For more information on analogue B4 lenses refer to the 'using servo zoom lenses' section

## Coarse Setting

The coarse setting is located to the left of the iris/pedestal control and is used to limit the iris range. This feature helps you prevent over exposed images from going to air.

To set your coarse threshold, completely open the iris using the iris control, then drag the coarse setting up or down to set optimum exposure. Now when you adjust the iris, the coarse threshold will prevent it from going above optimum exposure.

## Iris Indicator

The iris indicator is located to the left of the iris/pedestal control and displays a visual reference so you can easily see how open or closed the lens aperture is. The iris indicator is affected by the coarse setting.

## Auto Focus Button

The auto focus button is located at the bottom left corner of each camera controller. Press to automatically set the focus when you have an active lens that supports electronic focus adjustments. It's important to know that while most lenses support electronic focus, some lenses can be set to manual or auto focus modes, and so you need to ensure your lens is set to auto focus mode. Sometimes this is set by sliding the focus ring on the lens forward or backward. On B4 lenses with servo zoom control, you will need to set the switch at the bottom of the handgrip to 'servo'.



Click on the auto focus button or drag the manual focus adjustment left or right to focus a compatible lens

## Manual Focus Adjustment

When you want to manually focus your lens using ATEM Camera Control, you can use the focus adjustment located at the bottom of each camera controller. Drag the wheel control left or right to manually adjust focus while viewing the video feed from the camera to ensure your image is nice and sharp.

Manual focus control is only available from your switcher when using B4 and PL lenses with servo focus controls. As EF lenses do not have servo focus this option is not available when using URSA Mini EF.

## Camera Gain

The name for some settings, such as 'gain' and 'shutter speed', differs between ATEM Switchers and URSA Mini. For example, instead of a film ISO rating, ATEM Switchers use 'gain' to describe a camera's sensitivity to light.

**TIP** The difference between the terms 'gain' and 'ISO' are primarily due to differences between studio broadcast equipment and traditional film equipment. Exposure on television studio cameras, for example, could be monitored live from the camera. Light sensitivity adjustments could be made electronically inside the camera. This is different to film cameras, which are mechanical in nature and rely upon traditional light measurement techniques combined with photochemical ISO ratings.

When operating in varying light conditions, you might want to increase or decrease your camera's gain to avoid under exposing your images. To do this click the left arrow to decrease gain and the right arrow to increase gain.

Your ATEM Switcher will display gain in dB. This corresponds to the ISO settings on your camera in the following way:

Gain	ISO
0	200
6	400
12	800
18	1600

Please note that while URSA Mini 4.6K can be set to 18dB of gain, URSA Mini 4K's maximum gain is 12dB

## Shutter Speed Control

Shutter speed control is used to change your URSA Mini's shutter angle.

As with gain control, this setting is named differently due to the terminology differences between film cameras and broadcast cameras. Functionally, however, increasing shutter speed is exactly the same as decreasing shutter angle.

The shutter speed control is located between the color wheel and the iris/pedestal control. Decrease or increase the shutter speed by hovering your mouse pointer over the shutter speed indicator and clicking the left or right arrow.

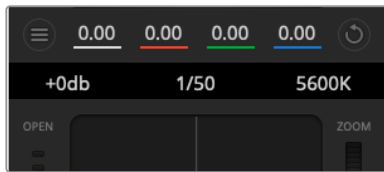

Hovering your mouse pointer over the gain, shutter speed and white balance indicators reveal arrows you can click on to adjust their respective settings

**NOTE** As ATEM shutter speed control takes priority over the shutter angle selected on your URSA Mini, your camera's shutter angle controls are disabled when connected to an ATEM switcher.

The table below shows the available shutter speeds in shutter speed control and their equivalent shutter angles. It's worth noting that some shutter speeds fall outside of URSA Mini's minimum and maximum shutter angles of 11.25 and 360 degrees, respectively. If this happens, the closest available shutter angle is used.

When your URSA Mini 4.6K or URSA Mini Pro is connected to an ATEM switcher, the shutter speed setting will also be visible in your camera's touchscreen status display. On URSA Mini 4K the shutter speed will not be displayed on the touchscreen, but will be visible in an URSA Viewfinder if attached.

If you have shutter angle selected on URSA Mini 4.6K or URSA Mini Pro, the table below applies.

Shutter Speed	Shutter Angle at 23.98 fps	Shutter Angle at 24 fps	Shutter Angle at 25 fps	Shutter Angle at 29.97 fps	Shutter Angle at 50 fps	Shutter Angle at 59.94 fps
1/50	172.7	172.8	180	215.8	360	360*
1/60	143.9	144	150	179.8	300	359.6
1/75	115.1	115.2	120	143.9	240	287.7
1/90	95.9	96	100	120	200	239.8
1/100	86.3	86.4	90	107.9	180	215.8
1/120	71.9	72	75	89.9	150	179.8
1/150	57.5	57.6	60	71.9	120	143.9
1/180	48	48	50	59.9	100	119.9
1/250	34.5	34.6	36	43.2	72	86.3
1/360	24	24	25	29.97	50	59.94
1/500	17.3	17.3	18	21.6	36	43.2
1/725	11.9	11.9	12.4	14.9	24.8	29.8
1/1450	11.25*	11.25*	11.25*	11.25*	12.4	14.9
1/2000	11.25*	11.25*	11.25*	11.25*	11.25*	11.25*

\*Shutter speeds outside URSA Mini's shutter angle range will use its closest available minimum or maximum shutter angle

**TIP** Decreasing shutter speed is a good way to brighten your images without using camera gain because you are increasing the exposure time of the image sensor. This can also reduce or eliminate light flicker when shooting under fluorescent lights. Increasing shutter speed reduces motion blur and is best used for action shots when you want your images to be clean and sharp.

## White Balance

The white balance setting next to the shutter speed control can be adjusted by clicking on the left or right arrows on each side of the color temperature indicator. Different light sources emit warm or cool colors, so you can compensate by adjusting the white balance. This ensures the whites in your image stay white.

## DaVinci Resolve Primary Color Corrector

If you have a color correction background, then you can change the camera control from a switcher style CCU interface to a user interface that's more like a primary color corrector on a post production color grading system.

Your Blackmagic URSA Mini features a DaVinci Resolve primary color corrector built in. If you have used DaVinci Resolve, then creatively, grading in your URSA Mini will be identical so you can use your color grading experience for live production. The color corrector panel can be expanded out of any camera controller and provides expanded color correction control with extra settings and a full primary color corrector interface.

You have color wheels and settings such as saturation available and you can see shadows, mid tones and highlight settings all at the same time. Simply switch between cameras using the camera selection controls at the top of the window as you need.

**TIP** DaVinci Resolve color correction is applied to your URSA Mini's SDI Output and ProRes video recorded on camera. As RAW video is intended for extensive post processing, color correction is not applied to RAW video. When recording RAW video, however, color correction can still be applied to URSA Mini's SDI output.



Click on the DaVinci Resolve primary color corrector button to expand the color correction window and adjust settings

### Color Wheels

The Lift/Gamma/Gain controls allow tonally specific yet overlapping regions of adjustment. In photographic terms lift, gamma and gain corresponds to shadows, mid tones and highlights.

Use the color wheels in the following ways to make fine or aggressive adjustments:

- **Click and drag anywhere within the color ring:**  
Note that you don't need to drag the color balance indicator itself. As the color balance indicator moves, the RGB parameters underneath change to reflect the adjustments being made to each channel.
- **Shift-Click and drag within the color ring:**  
Jumps the color balance indicator to the absolute position of the pointer, letting you make faster and more extreme adjustments.

- **Double-click within the color ring:**  
Resets the color adjustment without resetting the master wheel adjustment for that control.
- **Click the reset control at the upper-right of a color ring:**  
Resets both the color balance control and its corresponding master wheel.

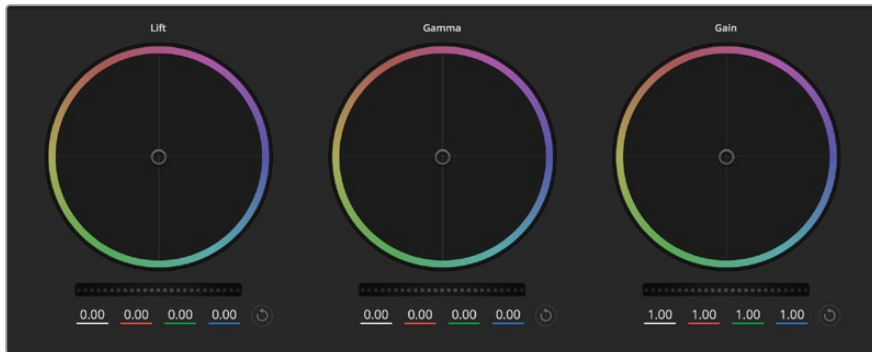

Lift, gamma and gain color wheels in the color corrector panel

## Master Wheels

Use the master wheels below the color wheels to adjust each YRGB channels' lift, gamma and gain controls.

To make adjustments using the master wheel:

- **Drag the master wheel left or right:**  
Dragging to the left darkens the selected parameter of the image, dragging to the right lightens that parameter. As you make an adjustment, the YRGB parameters underneath change to reflect the adjustment you're making. To make a Y-only adjustment, hold down the ALT or Command key and drag left or right. Because the color corrector uses YRGB processing, you can get quite creative and create unique affects by adjusting the Y channel only. Y channel adjustments work best when the Lum Mix setting is set to the right side to use YRGB processing vs the left side to use regular RGB processing. Normally, most DaVinci Resolve colorists use the YRGB color corrector as you get a lot more control of color balance without affecting overall gain, so you spend less time getting the look you want.

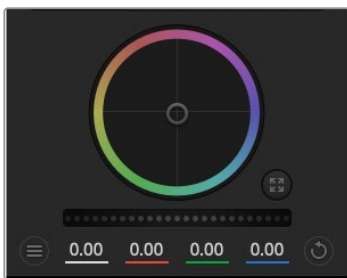

Adjust the master wheels by dragging the wheel control left or right

## Contrast Setting

The Contrast setting gives you control over the distance between the darkest and lightest values of an image. The effect is similar to making opposing adjustments using the lift and gain master wheels. The default setting is 50%.

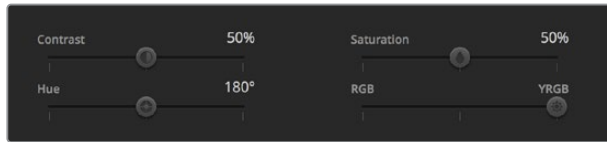

Drag the sliders left or right to adjust Contrast, Saturation, Hue and Lum Mix settings

## Saturation Setting

The Saturation setting increases or decreases the amount of color in the image. The default setting is 50%.

## Hue Setting

The Hue setting rotates all hues of the image around the full perimeter of the color wheel. The default setting of 180 degrees shows the original distribution of hues. Raising or lowering this value rotates all hues forward or backward along the hue distribution as seen on a color wheel.

## Lum Mix Setting

The color corrector built into your Blackmagic URSA Mini is based on the DaVinci Resolve primary color corrector. DaVinci has been building color correctors since the early 1980's and most Hollywood films are color graded on DaVinci Resolve than any other method.

This means the color corrector built into your URSA Mini has some unique and creatively powerful features. The YRGB processing is one of those features.

When color grading, you can choose to use RGB processing, or YRGB processing. High end colorists use YRGB processing because you have more precise control over color and you can independently adjust the channels with better separation and more creative options.

When the Lum Mix control is set to the right side, you have the 100% output of the YRGB color corrector. When you have the Lum Mix control set to the left side, you get 100% output of the RGB corrector. You can set the Lum Mix to any position between the left and right to get a blend of output from both the RGB and YRGB correctors.

Which is the correct setting to use? That's up to you, as color correction is a pure creative process and there is no right and wrong, and the best setting is what you like the most and what you think looks good!

## Synchronizing Settings

When connected, camera control signals are sent from the ATEM switcher to your Blackmagic URSA Mini. If a setting is accidentally adjusted from your URSA Mini, camera control will automatically reset that setting to maintain synchronization.

**TIP** Even if you disconnect its 12G-SDI input, your URSA Mini will keep using any image adjustments made with DaVinci Resolve color correction. This lets you change camera angles without needing to dial in your image settings again. To return your URSA Mini to its default color settings, simply power cycle your URSA Mini after disconnecting its 12G-SDI input.

# Blackmagic Camera Setup Utility

## Updating Camera Software – Mac

After downloading the Blackmagic Camera Setup utility software and unzipping the downloaded file, open the resulting disk image to reveal the Blackmagic Camera Setup Installer.

Launch the installer and follow the on screen instructions. After the installation has finished, go to your applications folder and open the Blackmagic Cameras folder, where you'll find this manual, the Blackmagic Camera setup utility, plus a documents folder containing readme files and information. You'll also find an uninstaller for when updating to later versions of Blackmagic Camera Setup.

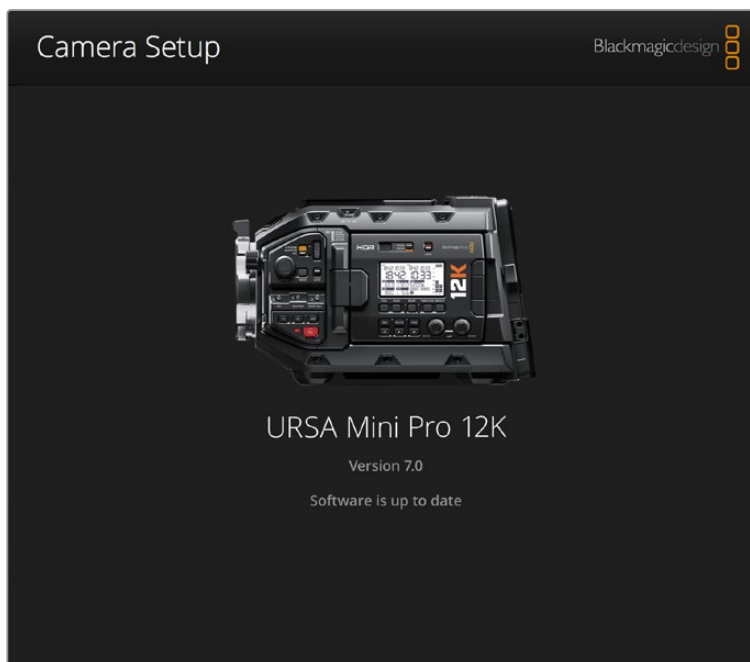

## Updating Camera Software – Windows

After downloading the Blackmagic Camera Setup utility software and unzipping the downloaded file, you should see a Blackmagic Camera Setup folder containing this PDF manual and the Blackmagic Camera Setup Installer. Double-click the installer and follow the on screen prompts to complete the installation.

In Windows 10, click the start button and select 'all apps'. Scroll down to the Blackmagic design folder. From here you can launch Blackmagic Camera Setup.

In Windows 8.1, select the down arrow icon from the 'start' screen, and scroll down to the Blackmagic Design folder. From here you can launch Blackmagic Camera Setup.



## How to Update the Camera Software

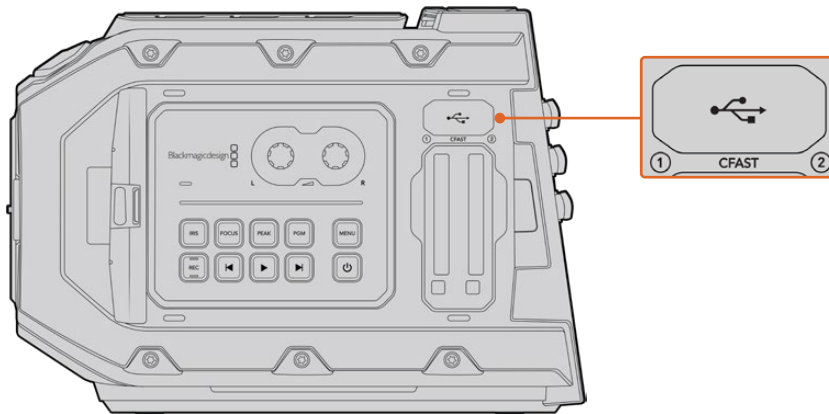

The Mini-B USB 2.0 port is used to update the camera software and can be found above the memory card slots on Blackmagic URSA Mini

After installing the latest Blackmagic Camera Setup utility on your computer, connect a USB cable between the computer and your Blackmagic URSA Mini. On Blackmagic URSA Mini, the USB port is located on the left side panel above the memory card slots. Simply open the rubber cap to access the port.

Launch the Blackmagic Camera Setup utility and follow the on screen prompts to update the camera software. It's important to note that updating your camera software erases any presets and custom LUTs, and resets all settings. It is a good practice to export them to a memory card as a backup before performing a software update. After a software update, you can restore your presets and LUTs quickly by importing them from the memory card. You are also advised to perform a black shading calibration.

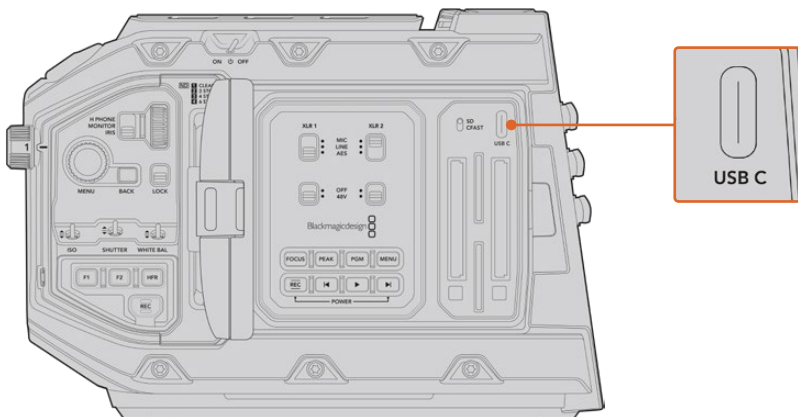

The USB-C port is used to update the camera software and can be found above the memory card slots, next to the media selection switch on Blackmagic URSA Mini Pro

## Working with Third Party Software

To edit your clips using your favorite editing software, you can copy your clips to an internal/external drive or RAID and then import your clips into the software. Or import your clips directly from your storage media using a dock or adapter for your CFast or SD card or SSD.

**NOTE** Blackmagic RAW is supported in DaVinci Resolve 15.3.1 and later and has also been adopted by a wide range of third party post-production editing programs. Plugins for editing Blackmagic RAW in Avid Media Composer and Adobe Premiere Pro are available with Blackmagic RAW software, which you can download from [www.blackmagicdesign.com/support](http://www.blackmagicdesign.com/support).

## Working with Files from CFast 2.0 and SD cards

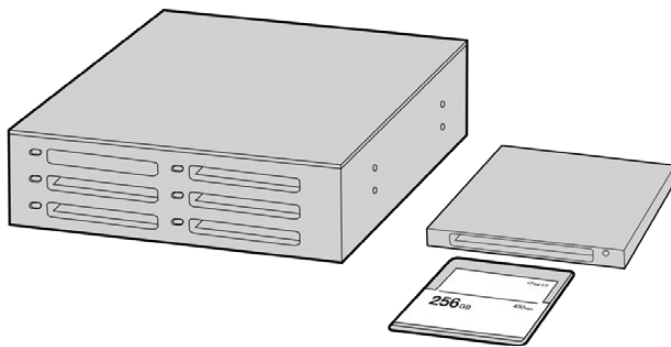

Edit directly from your CFast card by removing it from your camera and mounting it on your computer using a CFast 2.0 reader/writer or CFast drive

To import your clips from a CFast 2.0 or SD card:

- 1 Remove the CFast or SD card from your Blackmagic URSA Mini or URSA Mini Pro. Mount the CFast card to your Mac or Windows computer using a CFast or SD card reader.
- 2 Navigate to the card on your operating system to open it and you will see your list of Blackmagic RAW or QuickTime movie files.
- 3 Now you can simply drag the files you want from the card onto your desktop or another hard drive, or you can access the files straight from the card using your editing software.
- 4 Before you unplug the CFast or SD card from your computer, it is important to always eject your CFast or SD card from either Mac or Windows. Removing your card without ejecting can corrupt footage in some cases.

## Working with Files from SSDs

To import your clips from a SSD:

- 1 Remove the SSD from URSA Mini Recorder.
- 2 You can mount the SSD to your Mac or Windows computer using either an eSATA or Thunderbolt dock, for example Blackmagic Multidock 10G. You can also use an eSATA to USB adapter cable to plug the SSD straight into a USB port on your computer. USB 3.0 is preferable as USB 2.0 is not fast enough to edit video in real time.
- 3 Double click on the SSD to open it and you should see a list of QuickTime movie files or Blackmagic RAW files. Depending on the format you chose to record in, you might have a mixture of files, but they will all use the same naming convention.
- 4 Now you can simply drag the files you want from the SSD onto your desktop or another hard drive, or you can access the files straight from the SSD using your NLE software.
- 5 Before you unplug the SSD from your computer, it is important to eject the SSD safely from your computer first.

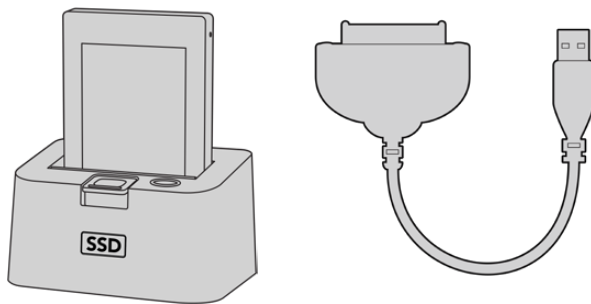

Edit directly from the SSD by removing it from your camera and mounting it on your computer using an eSATA Thunderbolt dock or USB 3.0 docking cable.

## Using Final Cut Pro X

To edit your clips using Final Cut Pro X, you need to create a new project and set a suitable video format and frame rate. This example uses ProRes 422 HQ 1080p24.

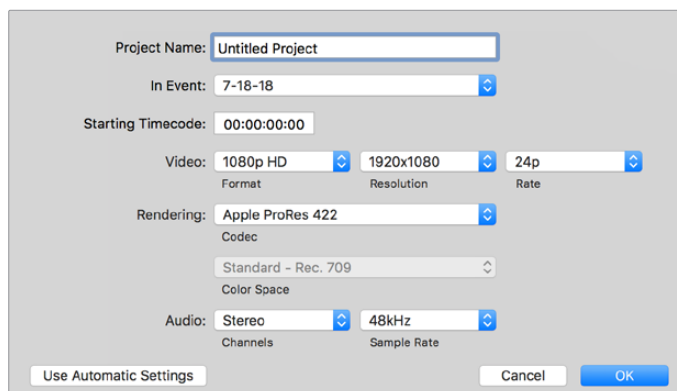

Final Cut Pro X project settings

- 1 Launch Final Cut Pro X, go to the 'menu' bar and select 'file/new project'. A window will open containing project settings.
- 2 Name your project and select the 'custom' checkbox.
- 3 Set the 'video properties' settings to 1080p HD, 1920x1080 and 24p.
- 4 Set your 'audio' and 'render properties' settings to 'stereo, 48kHz, and Apple ProRes 422 HQ'
- 5 Click OK.

To import your clips into your project, go to the 'menu' bar and select 'file/import/media'. Choose your clips from your CFast card.

You can now drag your clips onto the timeline for editing.

## Using Avid Media Composer 2018

To edit your clips using Avid Media Composer 2018, create a new project and set a suitable video format and frame rate. For this example, clips are set using 1080p24.

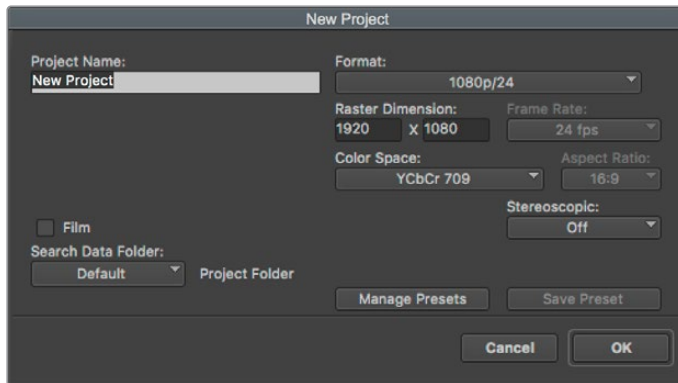

Setting the project name and project options in Avid Media Composer 2018

- 1 Launch Avid Media Composer 2018 and the 'select project' window will appear.
- 2 Click the 'new project' button and name your project in the 'new project' window.
- 3 In the 'format' drop down menu select HD 1080 > 1080p/24 and click 'ok' to create the project.
- 4 Double click the project in the 'select project' window to open it.
- 5 Select file > input > source browser and navigate to the files you wish to import.
- 6 Select your 'target bin' from the drop down menu and click 'import'.

When the clips appear within the media bin you can drag your clips onto the timeline and begin editing.

## Using Adobe Premiere Pro CC

To edit your Apple ProRes 422 HQ clips using Adobe Premiere Pro CC, you need to create a new project and set a suitable video format and frame rate. For this example, clips are set using ProRes 422 HQ 1080p25.

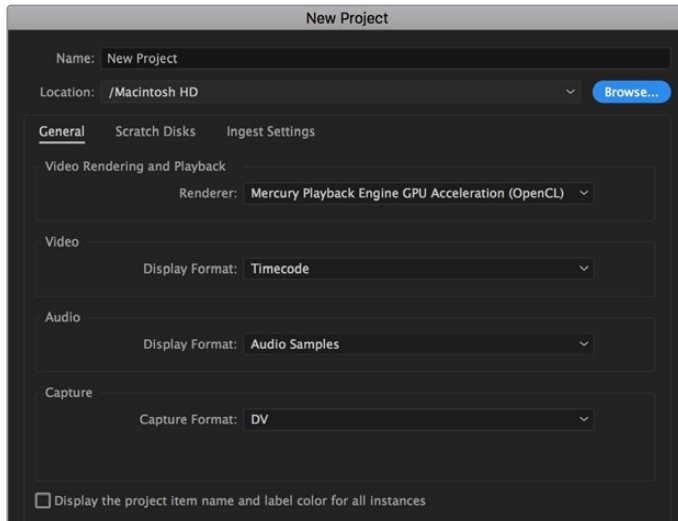

Setting the project name and project options in Adobe Premiere Pro CC

- 1 Launch Adobe Premiere Pro CC. In the 'welcome' window select 'new project'. A window will open containing project settings.
- 2 Name your project. Choose the location for your project by clicking 'browse' and selecting your desired folder. Once you've selected your location folder click OK in the 'new project' window.
- 3 Go to the Adobe Premiere Pro CC 'menu' bar, select 'file/import' and choose the clips you want to edit. Your clips will appear in the project window.
- 4 Drag the first clip you wish to edit onto the 'new item' icon at the bottom right of the project window. A new sequence will be created matching your clip settings.

You can now drag your clips onto the sequence timeline for editing.

# Developer Information

## Blackmagic Bluetooth Camera Control

Blackmagic cameras with Bluetooth LE implement a variety of features and commands that allow users to control their cameras wirelessly. Developers have full access to these features for their custom applications.

The following services and characteristics describe the full range of communication options that are available to the developer.

### Service: Device Information Service

UUID: 180A

#### Characteristics

##### **Camera Manufacturer**

UUID: 2A29

Read the name of the manufacturer (always “Blackmagic Design”).

##### **Camera Model**

UUID: 2A24

Read the name of the camera model (“URSA Mini”).

### Service: Blackmagic Camera Service

UUID: 291D567A-6D75-11E6-8B77-86F30CA893D3

#### Characteristics

##### **Outgoing Camera Control (encrypted)**

UUID: 5DD3465F-1AEE-4299-8493-D2ECA2F8E1BB

##### **Send Camera Control messages**

These messages are identical to those described in the Blackmagic SDI Camera Control Protocol section below. Please read that section for a list of supported messages and required formatting information.

For an example of how packets are structured, please see the ‘example protocol packets’ section in this document.

##### **Incoming Camera Control (encrypted)**

UUID: B864E140-76A0-416A-BF30-5876504537D9

Request notifications for this characteristic to receive Camera Control messages from the camera.

These messages are identical to those described in the Blackmagic SDI Camera Control Protocol section below. Please read that section for a list of supported messages and required formatting information.

### Timecode (encrypted)

UUID: 6D8F2110-86F1-41BF-9AFB-451D87E976C8

Request notifications for this characteristic to receive timecode updates.

Timecode (HH:MM:SS:mm) is represented by a 32-bit BCD number:  
(eg. 09:12:53:10 = 0x09125310)

### Camera Status (encrypted)

UUID: 7FE8691D-95DC-4FC5-8ABD-CA74339B51B9

Request notifications for this characteristic to receive camera status updates.

The camera status is represented by flags contained in an 8-bit integer:

<b>None</b>	= 0x00
<b>Camera Power On</b>	= 0x01
<b>Connected</b>	= 0x02
<b>Paired</b>	= 0x04
<b>Versions Verified</b>	= 0x08
<b>Initial Payload Received</b>	= 0x10
<b>Camera Ready</b>	= 0x20

Send a value of 0x00 to power a connected camera off.

Send a value of 0x01 to power a connected camera on.

### Device Name

UUID: FFAC0C52-C9FB-41A0-B063-CC76282EB89C

Send a device name to the camera (max. 32 characters).

The camera will display this name in the Bluetooth Setup Menu.

### Protocol Version

UUID: 8F1FD018-B508-456F-8F82-3D392BEE2706

Read this value to determine the camera's supported CCU protocol version.

**NOTE** Encrypted characteristics can only be used once a device has successfully bonded or paired with the Blackmagic Camera. Once a connection has been established, any attempt to write to an encrypted characteristic will initiate bonding. For example, writing a 'Camera Power On' (0x01) message to the Camera Status characteristic.

Once bonding is initiated, the camera will display a 6-digit pin in the Bluetooth Setup Menu. Enter this pin on your device to establish an encrypted connection. The device will now be able to read, write and receive notifications from encrypted characteristics.

# Blackmagic SDI and Bluetooth Camera Control Protocol

## Version 1.4

If you are a software developer you can use the Blackmagic SDI and Bluetooth Camera Control Protocol to construct devices that integrate with our products. Here at Blackmagic Design, our approach is to open up our protocols and we eagerly look forward to seeing what you come up with!

## Overview

This document describes an extensible protocol for sending a unidirectional stream of small control messages embedded in the non-active picture region of a digital video stream. The video stream containing the protocol stream may be broadcast to a number of devices. Device addressing is used to allow the sender to specify which device each message is directed to.

## Assumptions

Alignment and padding constraints are explicitly described in the protocol document. Bit fields are packed from LSB first. Message groups, individual messages and command headers are defined as, and can be assumed to be, 32 bit aligned.

## Blanking Encoding

A message group is encoded into a SMPTE 291M packet with DID/SDID x51/x53 in the active region of VANC line 16.

## Message Grouping

Up to 32 messages may be concatenated and transmitted in one blanking packet up to a maximum of 255 bytes payload. Under most circumstances, this should allow all messages to be sent with a maximum of one frame latency.

If the transmitting device queues more bytes of message packets than can be sent in a single frame, it should use heuristics to determine which packets to prioritize and send immediately. Lower priority messages can be delayed to later frames, or dropped entirely as appropriate.

## Abstract Message Packet Format

Every message packet consists of a three byte header followed by an optional variable length data block. The maximum packet size is 64 bytes.

<b>Destination device (uint8)</b>	Device addresses are represented as an 8 bit unsigned integer. Individual devices are numbered 0 through 254 with the value 255 reserved to indicate a broadcast message to all devices.
<b>Command length (uint8)</b>	The command length is an 8 bit unsigned integer which specifies the length of the included command data. The length does NOT include the length of the header or any trailing padding bytes.
<b>Command id (uint8)</b>	The command id is an 8 bit unsigned integer which indicates the message type being sent. Receiving devices should ignore any commands that they do not understand. Commands 0 through 127 are reserved for commands that apply to multiple types of devices. Commands 128 through 255 are device specific.
<b>Reserved (uint8)</b>	This byte is reserved for alignment and expansion purposes. It should be set to zero.
<b>Command data (uint8[])</b>	The command data may contain between 0 and 60 bytes of data. The format of the data section is defined by the command itself.
<b>Padding (uint8[])</b>	Messages must be padded up to a 32 bit boundary with 0x0 bytes. Any padding bytes are NOT included in the command length.

Receiving devices should use the destination device address and or the command identifier to determine which messages to process. The receiver should use the command length to skip irrelevant or unknown commands and should be careful to skip the implicit padding as well.



## Defined Commands

### Command 0 : change configuration

---

<b>Category (uint8)</b>	The category number specifies one of up to 256 configuration categories available on the device.
<b>Parameter (uint8)</b>	The parameter number specifies one of 256 potential configuration parameters available on the device. Parameters 0 through 127 are device specific parameters. Parameters 128 through 255 are reserved for parameters that apply to multiple types of devices.
<b>Data type (uint8)</b>	The data type specifies the type of the remaining data. The packet length is used to determine the number of elements in the message. Each message must contain an integral number of data elements.

---

#### Currently defined values are:

---

<b>0: void / boolean</b>	A void value is represented as a boolean array of length zero. The data field is a 8 bit value with 0 meaning false and all other values meaning true.
<b>1: signed byte</b>	Data elements are signed bytes
<b>2: signed 16 bit integer</b>	Data elements are signed 16 bit values
<b>3: signed 32 bit integer</b>	Data elements are signed 32 bit values
<b>4: signed 64 bit integer</b>	Data elements are signed 64 bit values
<b>5: UTF-8 string</b>	Data elements represent a UTF-8 string with no terminating character.

---

#### Data types 6 through 127 are reserved.

---

<b>128: signed 5.11 fixed point</b>	Data elements are signed 16 bit integers representing a real number with 5 bits for the integer component and 11 bits for the fractional component. The fixed point representation is equal to the real value multiplied by $2^{11}$ . The representable range is from -16.0 to 15.9995 ( $15 + 2047/2048$ ).
-------------------------------------	---

---

#### Data types 129 through 255 are available for device specific purposes.

---

<b>Operation type (uint8)</b>	The operation type specifies what action to perform on the specified parameter. Currently defined values are:
<b>0: assign value</b>	The supplied values are assigned to the specified parameter. Each element will be clamped according to its valid range. A void parameter may only be 'assigned' an empty list of boolean type. This operation will trigger the action associated with that parameter. A boolean value may be assigned the value zero for false, and any other value for true.
<b>1: offset / toggle value</b>	Each value specifies signed offsets of the same type to be added to the current parameter values. The resulting parameter value will be clamped according to their valid range. It is not valid to apply an offset to a void value. Applying any offset other than zero to a boolean value will invert that value.

---

#### Operation types 2 through 127 are reserved.

#### Operation types 128 through 255 are available for device specific purposes.

---

<b>Data (void)</b>	The data field is 0 or more bytes as determined by the data type and number of elements.
--------------------	--

---

The category, parameter, data type and operation type partition a 24 bit operation space.

Group	ID	Parameter	Type	Index	Minimum	Maximum	Interpretation	
Lens	0.0	Focus	fixed16	–	0.0	1.0	0.0 = near, 1.0 = far	
	0.1	Instantaneous autofocus	void	–	–	–	trigger instantaneous autofocus	
	0.2	Aperture (f-stop)	fixed16	–	-1.0	16.0	Aperture Value (where fnumber = $\sqrt{2^{AV}}$ )	
	0.3	Aperture (normalised)	fixed16	–	0.0	1.0	0.0 = smallest, 1.0 = largest	
	0.4	Aperture (ordinal)	int16	–	0	n	Steps through available aperture values from minimum (0) to maximum (n)	
	0.5	Instantaneous auto aperture	void	–	–	–	trigger instantaneous auto aperture	
	0.6	Optical image stabilisation	boolean	–	–	–	true = enabled, false = disabled	
	0.7	Set absolute zoom (mm)	int16	–	0	max	Move to specified focal length in mm, from minimum (0) to maximum (max)	
	0.8	Set absolute zoom (normalised)	fixed16	–	0.0	1.0	Move to specified focal length: 0.0 = wide, 1.0 = tele	
0.9	Set continuous zoom (speed)	fixed16	–	-1.0	+1.0	Start/stop zooming at specified rate: -1.0 = zoom wider fast, 0.0 = stop, +1 = zoom tele fast		
Video	1.0	Video mode	int8	[0] = frame rate	–	–	fps as integer (eg 24, 25, 30, 50, 60)	
				[1] = M-rate	–	–	0 = regular, 1 = M-rate	
				[2] = dimensions	–	–	0 = NTSC, 1 = PAL, 2 = 720, 3 = 1080, 4 = 2kDCI, 5 = 2k16:9, 6 = UHD, 7 = 3k Anamorphic, 8 = 4k DCI, 9 = 4k 16:9, 10 = 4.6k 2.4:1, 11 = 4.6k	
				[3] = interlaced	–	–	0 = progressive, 1 = interlaced	
				[4] = Color space	–	–	0 = YUV	
	1.1	Gain (up to Camera 4.9)	int8			1	128	1x, 2x, 4x, 8x, 16x, 32x, 64x, 128x gain
	1.2	Manual White Balance	int16	[0] = color temp	2500	10000		Color temperature in K
			int16	[1] = tint	-50	50		tint
	1.3	Set auto WB	void	–	–	–	–	Calculate and set auto white balance
	1.4	Restore auto WB	void	–	–	–	–	Use latest auto white balance setting
1.5	Exposure (us)	int32			1	42000	time in us	
1.6	Exposure (ordinal)	int16	–		0	n	Steps through available exposure values from minimum (0) to maximum (n)	
1.7	Dynamic Range Mode	int8 enum	–		0	2	0 = film, 1 = video, 2 = extended video	
1.8	Video sharpening level	int8 enum	–		0	3	0 = off, 1 = low, 2 = medium, 3 = high	

Group	ID	Parameter	Type	Index	Minimum	Maximum	Interpretation
Video	1.9	Recording format	int16	[0] = file frame rate	–	–	fps as integer (eg 24, 25, 30, 50, 60, 120)
				[1] = sensor frame rate	–	–	fps as integer, valid when sensor-off-speed set (eg 24, 25, 30, 33, 48, 50, 60, 120), no change will be performed if this value is set to 0
				[2] = frame width	–	–	in pixels
				[3] = frame height	–	–	in pixels
				[4] = flags	–	–	[0] = file-M-rate
					–	–	[1] = sensor-M-rate, valid when sensor-off-speed-set
					–	–	[2] = sensor-off-speed
					–	–	[3] = interlaced
	–	–	[4] = windowed mode				
	1.10	Set auto exposure mode	int8	–	0	4	0 = Manual Trigger, 1 = Iris, 2 = Shutter, 3 = Iris + Shutter, 4 = Shutter + Iris
	1.11	Shutter angle	int32	–	100	36000	Shutter angle in degrees, multiplied by 100
	1.12	Shutter speed	int32	–	Current sensor frame rate	5000	Shutter speed value as a fraction of 1, so 50 for 1/50th of a second
	1.13	Gain	int8	–	-128	127	Gain in decibel (dB)
	1.14	ISO	int32	–	0	2147483647	ISO value
	1.15	Display LUT	int8	[0] = selected LUT	–	–	0 = None, 1 = Custom, 2 = film to video, 3 = film to extended video
[1] = enabled or not				–	–	0 = Not enabled, 1 = Enabled	
Audio	2.0	Mic level	fixed16	–	0.0	1.0	0.0 = minimum, 1.0 = maximum
	2.1	Headphone level	fixed16	–	0.1	1.0	0.0 = minimum, 1.0 = maximum
	2.2	Headphone program mix	fixed16	–	0.1	1.0	0.0 = minimum, 1.0 = maximum
	2.3	Speaker level	fixed16	–	0.1	1.0	0.0 = minimum, 1.0 = maximum
	2.4	Input type	int8	–	0	3	0 = internal mic, 1 = line level input, 2 = low mic level input, 3 = high mic level input
	2.5	Input levels	fixed16	[0] ch0	0.0	1.0	0.0 = minimum, 1.0 = maximum
				[1] ch1	0.0	1.0	0.0 = minimum, 1.0 = maximum
	2.6	Phantom power	boolean	–	–	–	true = powered, false = not powered

Group	ID	Parameter	Type	Index	Minimum	Maximum	Interpretation
Output	3.0	Overlay enables	uint16 bit field	–	–	–	bit flags: [0] = display status, [1] = display frame guides Some cameras don't allow separate control of frame guides and status overlays.
	3.1	Frame guides style (Camera 3.x)	int8	–	0	8	0 = HDTV, 1 = 4:3, 2 = 2.4:1, 3 = 2.39:1, 4 = 2.35:1, 5 = 1.85:1, 6 = thirds
	3.2	Frame guides opacity (Camera 3.x)	fixed16	–	0.1	1.0	0.0 = transparent, 1.0 = opaque
	3.3	Overlays (replaces .1 and .2 above from Cameras 4.0)	int8	[0] = frame guides style	–	–	0 = off, 1 = 2.4:1, 2 = 2.39:1, 3 = 2.35:1, 4 = 1.85:1, 5 = 16:9, 6 = 14:9, 7 = 4:3, 8 = 2:1, 9 = 4:5, 10 = 1:1
			[1] = frame guide opacity	0	100	0 = transparent, 100 = opaque	
			[2] = safe area percentage	0	100	percentage of full frame used by safe area guide (0 means off)	
			[3] = grid style	–	–	bit flags: [0] = display thirds, [1] = display cross hairs, [2] = display center dot, [3] = display horizon	
Display	4.0	Brightness	fixed16	–	0.0	1.0	0.0 = minimum, 1.0 = maximum
	4.1	Exposure and focus tools	int16 bit field	0x1 = zebra, 0x2 = focus assist, 0x4 = false color	–	–	0 = disable, 1 = enable
	4.2	Zebra level	fixed16	–	0.0	1.0	0.0 = minimum, 1.0 = maximum
	4.3	Peaking level	fixed16	–	0.0	1.0	0.0 = minimum, 1.0 = maximum
	4.4	Color bar enable	int8	–	0	30	0 = disable bars, 1-30 = enable bars with timeout (seconds)
	4.5	Focus Assist	int8	[0] = focus assist method	–	–	0 = Peak, 1 = Colored lines
				[1] = focus line color	–	–	0 = Red, 1 = Green, 2 = Blue, 3 = White, 4 = Black
	4.6	Program return feed enable	int8	–	0	30	0 = disable, 1-30 = enable with timeout (seconds)
Tally	5.0	Tally brightness	fixed16	–	0.0	1.0	Sets the tally front and tally rear brightness to the same level. 0.0 = minimum, 1.0 = maximum
	5.1	Front tally brightness	fixed16	–	0.0	1.0	Sets the tally front brightness. 0.0 = minimum, 1.0 = maximum
	5.2	Rear tally brightness	fixed16	–	0.0	1.0	Sets the tally rear brightness. 0.0 = minimum, 1.0 = maximum Tally rear brightness cannot be turned off

Group	ID	Parameter	Type	Index	Minimum	Maximum	Interpretation
Reference	6.0	Source	int8 enum	–	0	2	0 = internal, 1 = program, 2 = external
	6.1	Offset	int32	–	–	–	+/- offset in pixels
Confi- guration	7.0	Real Time Clock	int32	[0] time	–	–	BCD - HHMMSSFF (UCT)
				[1] date	–	–	BCD - YYYYMMDD
	7.1	System language	string	[0-1]	–	–	ISO-639-1 two character language code
	7.2	Timezone	int32	–	–	–	Minutes offset from UTC
	7.3	Location	int64	[0] latitude	–	–	BCD - s0DDdddddddddd where s is the sign: 0 = north (+), 1 = south (-); DD degrees, ddddddddddd decimal degrees
				[1] longitude	–	–	BCD - sDDDdddddddddd where s is the sign: 0 = west (-), 1 = east (+); DDD degrees, dddddddddd decimal degrees
Color Correction	8.0	Lift Adjust	fixed16	[0] red	-2.0	2.0	default 0.0
				[1] green	-2.0	2.0	default 0.0
				[2] blue	-2.0	2.0	default 0.0
				[3] luma	-2.0	2.0	default 0.0
	8.1	Gamma Adjust	fixed16	[0] red	-4.0	4.0	default 0.0
				[1] green	-4.0	4.0	default 0.0
				[2] blue	-4.0	4.0	default 0.0
				[3] luma	-4.0	4.0	default 0.0
	8.2	Gain Adjust	fixed16	[0] red	0.0	16.0	default 1.0
				[1] green	0.0	16.0	default 1.0
				[2] blue	0.0	16.0	default 1.0
				[3] luma	0.0	16.0	default 1.0
	8.3	Offset Adjust	fixed16	[0] red	-8.0	8.0	default 0.0
				[1] green	-8.0	8.0	default 0.0
				[2] blue	-8.0	8.0	default 0.0
				[3] luma	-8.0	8.0	default 0.0
	8.4	Contrast Adjust	fixed16	[0] pivot	0.0	1.0	default 0.5
				[1] adj	0.0	2.0	default 1.0
	8.5	Luma mix	fixed16	–	0.0	1.0	default 1.0
	8.6	Color Adjust	fixed16	[0] hue	-1.0	1.0	default 0.0
[1] sat				0.0	2.0	default 1.0	
8.7	Correction Reset Default	void	–	–	–	reset to defaults	

Group	ID	Parameter	Type	Index	Minimum	Maximum	Interpretation
Media	10.0	Codec	int8 enum	[0] = basic codec	-	-	0 = CinemaDNG, 1 = DNxHD, 2 = ProRes, 3 = Blackmagic RAW
				[1] = code variant	-	-	CinemaDNG: 0 = uncompressed, 1 = lossy 3:1, 2 = lossy 4:1
					-	-	ProRes: 0 = HQ, 1 = 422, 2 = LT, 3 = Proxy, 4 = 444, 5 = 444XQ
					-	-	Blackmagic RAW: 0 = Q0, 1 = Q5, 2 = 3:1, 3 = 5:1, 4 = 8:1, 5 = 12:1
	10.1	Transport mode	int8	[0] = mode	-	-	0 = Preview, 1 = Play, 2 = Record
				[1] = speed	-	-	-ve = multiple speeds backwards, 0 = pause, +ve = multiple speeds forwards
				[2] = flags	-	-	1<<0 = loop, 1<<1 = play all, 1<<5 = disk1 active, 1<<6 = disk2 active, 1<<7 = time-lapse recording
				[3] = slot 1 storage medium	-	-	0 = CFast card, 1 = SD, 2 = SSD Recorder
				[4] = slot 2 storage medium	-	-	0 = CFast card, 1 = SD, 2 = SSD Recorder
	10.2	Playback Control	int8 enum	[0] = clip	-	-	0 = Previous, 1 = Next
PTZ Control	11.0	Pan/Tilt Velocity	fixed 16	[0] = pan velocity	-1.0	1.0	-1.0 = full speed left, 1.0 = full speed right
				[1] = tilt velocity	-1.0	1.0	-1.0 = full speed down, 1.0 = full speed up
	11.1	Memory Preset	int8 enum	[0] = preset command	-	-	0 = reset, 1 = store location, 2 = recall location
			int8	[1] = preset slot	0	5	-

## Example Protocol Packets

Operation	Packet Length	Byte															
		0	1	2	3	4	5	6	7	8	9	10	11	12	13	14	15
		header			command				data								
		destination	length	command	reserved	category	parameter	type	operation								
trigger instantaneous auto focus on camera 4	8	4	4	0	0	0	1	0	0								
turn on OIS on all cameras	12	255	5	0	0	0	6	0	0	1	0	0	0				
set exposure to 10 ms on camera 4 (10 ms = 10000 us = 0x00002710)	12	4	8	0	0	1	5	3	0	0x10	0x27	0x00	0x00				
add 15% to zebra level (15 % = 0.15 f = 0x0133 fp)	12	4	6	0	0	4	2	128	1	0x33	0x01	0	0				
select 1080p 23.98 mode on all cameras	16	255	9	0	0	1	0	1	0	24	1	3	0	0	0	0	0
subtract 0.3 from gamma adjust for green & blue (-0.3 ~ = 0xfd9a fp)	16	4	12	0	0	8	1	128	1	0	0	0x9a	0xfd	0x9a	0xfd	0	0
all operations combined	76	4	4	0	0	0	1	0	0	255	5	0	0	0	6	0	0
		1	0	0	0	4	8	0	0	1	5	3	0	0x10	0x27	0x00	0x00
		4	6	0	0	4	2	128	1	0x33	0x01	0	0	255	9	0	0
		1	0	1	0	24	1	3	0	0	0	0	0	4	12	0	0
		8	1	128	1	0	0	0x9a	0xfd	0x9a	0xfd	0	0				

## Blackmagic Tally Control Protocol

### Version 1.0 (30/04/14)

This section is for third party developers or anybody who may wish to add support for the Blackmagic Tally Control Protocol to their products or system. It describes the protocol for sending tally information embedded in the non-active picture region of a digital video stream.

### Data Flow

A master device such as a broadcast switcher embeds tally information into its program feed which is broadcast to a number of slave devices such as cameras or camera controllers. The output from the slave devices is typically fed back to the master device, but may also be sent to a video monitor.

The primary flow of tally information is from the master device to the slaves. Each slave device may use its device id to extract and display the relevant tally information.

Slave devices pass through the tally packet on their output and update the monitor tally status, so that monitor devices connected to that individual output may display tally status without knowledge of the device id they are monitoring.

## Assumptions

Any data alignment / padding is explicit in the protocol. Bit fields are packed from LSB first.

## Blanking Encoding

One tally control packet may be sent per video frame. Packets are encoded as a SMPTE 291M packet with DID/SDID x51/x52 in the active region of VANC line 15. A tally control packet may contain up to 256 bytes of tally information.

## Packet Format

Each tally status consists of 4 bits of information:

```
uint4
    bit 0:  program tally status (0=off, 1=on)
    bit 1:  preview tally status (0=off, 1=on)
    bit 2-3: reserved (0x0)
```

The first byte of the tally packet contains the monitor device tally status and a version number.

Subsequent bytes of the tally packet contain tally status for pairs of slave devices. The master device sends tally status for the number of devices configured/supported, up to a maximum of 510.

struct tally

```
uint8
    bit 0:  monitor device program tally status (0=off, 1=on)
    bit 1:  monitor device preview tally status (0=off, 1=on)
    bit 2-3: reserved (0b00)
    bit 4-7: protocol version (0b0000)

uint8[0]
    bit 0:  slave device 1 program tally status (0=off, 1=on)
    bit 1:  slave device 1 device preview tally status (0=off, 1=on)
    bit 2-3: reserved (0b00)
    bit 4:  slave device 2 program tally status (0=off, 1=on)
    bit 5:  slave device 2 preview tally status (0=off, 1=on)
    bit 6-7: reserved (0b00)

uint8[1]
    bit 0:  slave device 3 program tally status (0=off, 1=on)
    bit 1:  slave device 3 device preview tally status (0=off, 1=on)
    bit 2-3: reserved (0b00)
    bit 4:  slave device 4 program tally status (0=off, 1=on)
    bit 5:  slave device 4 preview tally status (0=off, 1=on)
    bit 6-7: reserved (0b00)

...
```



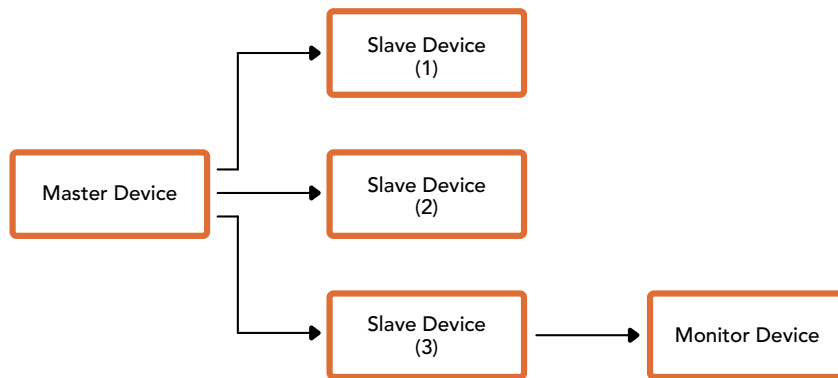

Byte	7 MSB	6	5	4	3	2	1	0 LSB
0	Version (0b0)	Version (0b0)	Version (0b0)	Version (0b0)	Reserved (0b0)	Reserved (0b0)	Monitor Preview	Monitor Program
1	Reserved (0b0)	Reserved (0b0)	Slave 1 Preview	Slave 1 Program	Reserved (0b0)	Reserved (0b0)	Slave 0 Preview	Slave 0 Program
2	Reserved (0b0)	Reserved (0b0)	Slave 3 Preview	Slave 3 Program	Reserved (0b0)	Reserved (0b0)	Slave 2 Preview	Slave 2 Program
3	...							

# Blackmagic URSA Mini B4 Mount

The PL mount on Blackmagic URSA Mini PL can be removed and replaced with an optional B4 mount. This mount differs slightly to the B4 mount on URSA Mini Pro. For example, the screw holes are in a different position to allow for the EF button release housing on URSA Mini Pro. The shim thicknesses required are also different, so if you want to use B4 lenses with your URSA Mini PL it's important you choose the correct mount.

The B4 mount for URSA Mini PL can be purchased from Blackmagic Design resellers.

Using the B4 mount, you can shoot ENG style HD coverage with URSA Mini PL using common par-focal zoom lenses. Par-focal lenses provide constant focus throughout the zoom range for quick and efficient focussing techniques. By zooming into maximum telephoto and setting focus on a target, you can be sure your focus will stay set to that target all the way from maximum zoom to maximum wide. It's important to note that the B4 lens back focus, or flange focal distance, also needs to be correctly set.

## Attaching the B4 Lens Mount

The B4 mount is supplied with two additional 0.50mm shims designed to be installed together with the existing 0.50mm shim already mounted behind your URSA Mini PL lens mount. This will give you a total of three 0.50mm shims to provide the clearance needed so you can achieve the optimum back focus, which can be refined further by adjusting the back focus ring at the mount end of B4 zoom lenses.

Using B4 lenses, you can achieve a greater variety of shots with your URSA Mini that are impossible to get using stills lenses.

To connect your URSA Mini B4 lens mount you'll need a torque wrench able to accurately set a maximum torque of 0.45Nm, plus a 2.0mm Hex key driver.



To attach the Blackmagic URSA Mini B4 Mount, you will need a torque wrench able to accurately set a maximum torque of 0.45Nm, together with a 2.0mm Hex key driver

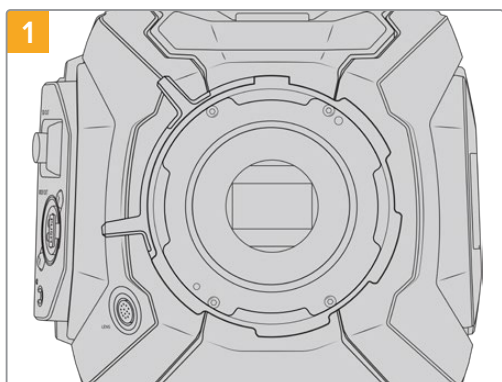

Place Blackmagic URSA Mini PL on a solid, clean bench top and remove your lens or dust cap. The glass filter covering the sensor will be exposed for the duration of the shimming process, so it's important to keep the filter as clean as possible. Be careful not to touch the filter while attaching the B4 mount.

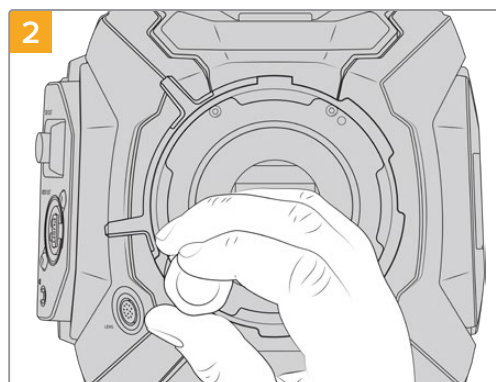

Remove the six PL mount screws using the 2.0mm Hex driver. You may need to occasionally rotate the PL locking ring clockwise or counterclockwise to access the screws.

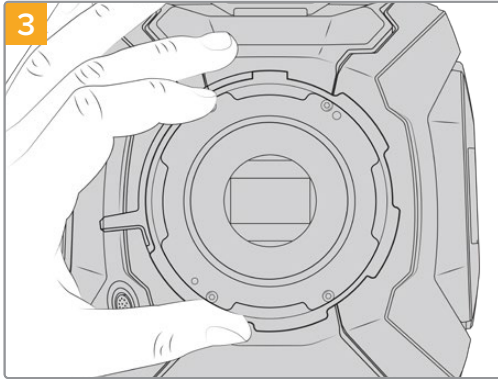

Carefully lift the lens mount away from the camera body. Keep the screws safely located close to the lens mount.

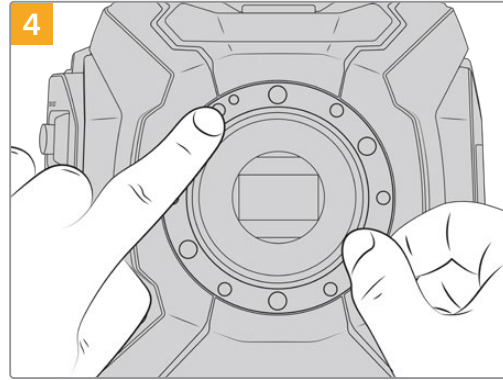

Note the alignment of the existing 0.50mm shim with the alignment pin at the 11 o'clock position.

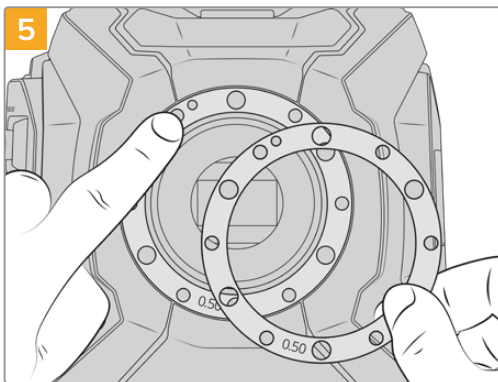

Place the 2 x 0.50mm shims supplied with your Blackmagic URSA Mini B4 lens mount onto the original 0.50mm shim. This creates the clearance needed to optimize the flange focal distance.

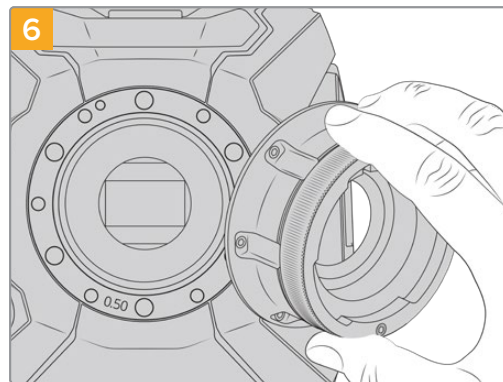

Carefully place the Blackmagic URSA Mini B4 lens mount onto the camera body ensuring the registration slot is aligned with the alignment pin at the 11 o'clock position.

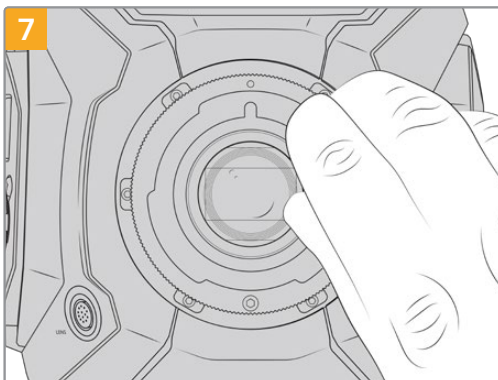

Using a 2mm Hex driver or torque wrench set to 0.45Nm, loosely turn the six mounting screws until initial contact is made with the shoulder of the lens mount.

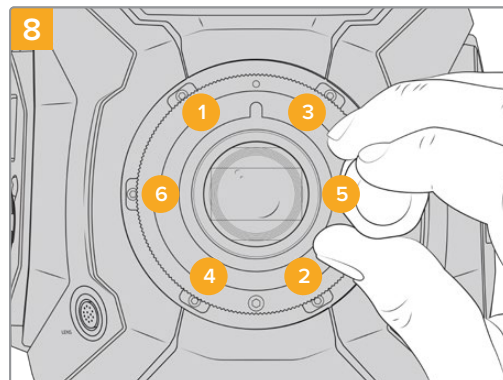

Confirm the lens mount is level and correctly aligned, then tighten the screws in the order shown here to an even pressure without over-tightening the screws.

# Shimming Lens Mounts

## What is a Shim?

Shims are thin disks of varying thickness that let you make fine adjustments to the distance between your lens and URSA Mini's sensor. This distance is commonly known as the flange focal distance, or back focus, and can change slightly due to variables such as lens age and the environmental conditions of your shoot. The following URSA Mini models are designed so you can easily adjust back focus using shims.

- URSA Mini PL 4K
- URSA Mini PL 4.6K
- URSA Mini Pro 4.6K
- URSA Mini Pro 4.6K G2

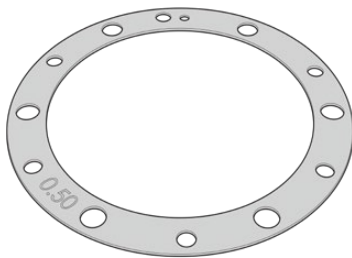

URSA Mini Shim



URSA Mini Pro Shim

Shims are placed between the lens mount and the camera body so the distance from your subject to the sensor matches the focus marks on your lens. These are most commonly used for PL lenses. These cine lenses are manually focused and have very accurate focal distance markings on their barrels. Shims are also used for URSA Mini Pro's interchangeable lens mount.

Your Blackmagic URSA Mini is supplied with a 0.50mm shim already installed. The Blackmagic URSA Mini Pro Shim Kit contains additional shim sets of various thicknesses, and can be purchased from your local Blackmagic Design reseller. A set of shims is also included with all mount kits for URSA Mini Pro. Use shim thicknesses depending on your back focus requirements.

## Shimming URSA Mini PL

To shim your camera's PL mount you'll need a torque wrench able to accurately set a maximum torque of 0.45Nm, with a 2.0mm Hex key and driver.

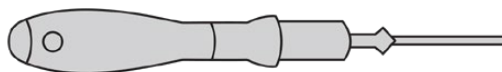

Torque wrench

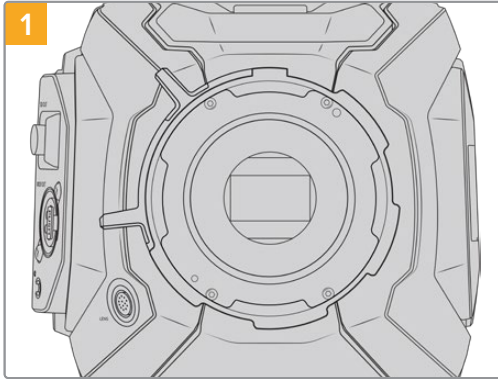

Place URSA Mini PL vertically on a solid, clean bench top and remove your lens or dust cap. The glass filter covering the sensor will be exposed for the duration of the shimming process, so it's important to keep the filter as clean as possible. Be careful not to touch the filter while shimming the PL mount.

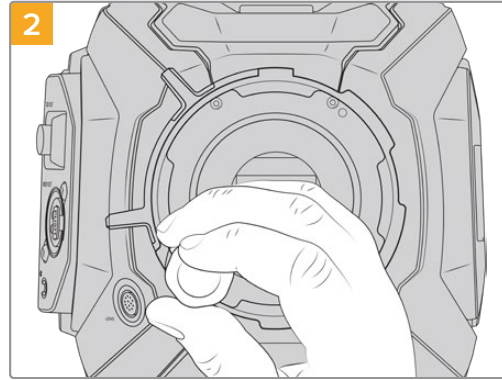

Remove the six PL mount screws using the 2.0mm Hex driver. You may need to occasionally rotate the PL locking ring clockwise or counterclockwise to access the screws.

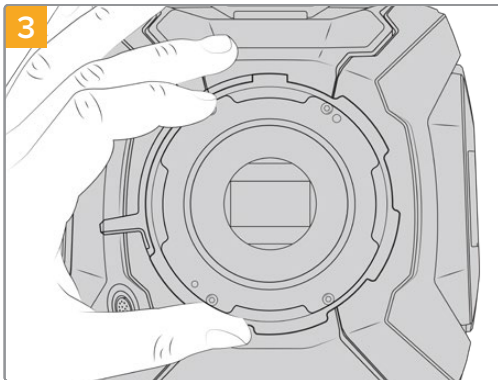

Carefully lift the lens mount away from the camera body. Keep the screws safely located close to the lens mount.

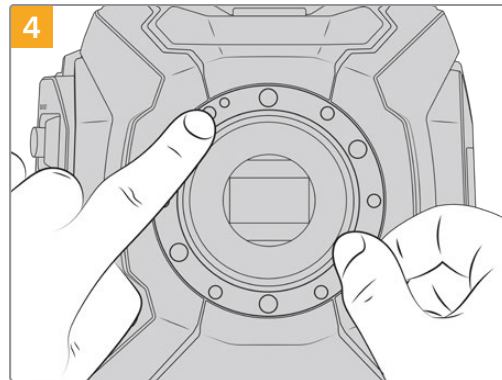

Note the alignment of the existing 0.50mm shim with the alignment pin at the 11 o'clock position.

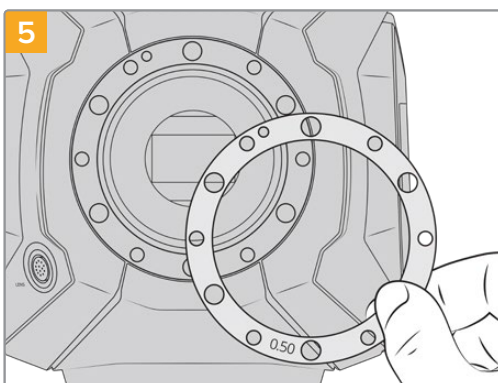

Add or remove shims in 0.10mm increments, and test with your lenses when the camera is reassembled to make sure they are hitting their marks. To 'remove' shims, you might replace your 0.50mm shim with a 0.40mm shim, for example.

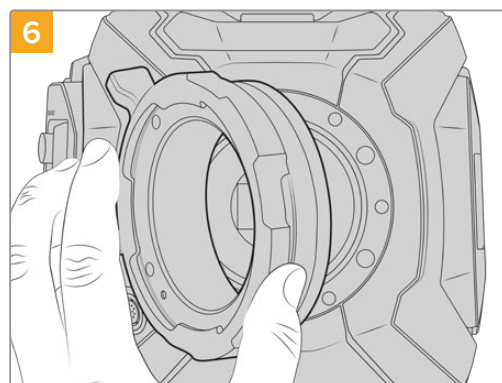

Carefully place the Blackmagic URSA Mini Pro PL lens mount onto the camera body.

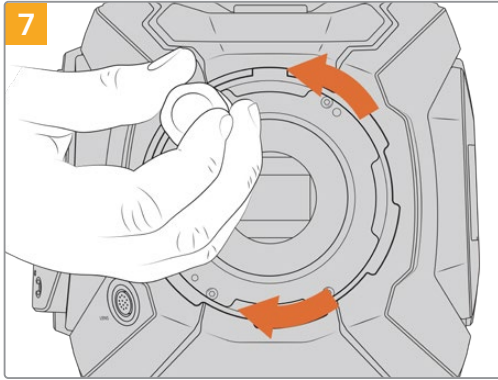

Using a 2mm Hex driver or torque wrench set to 0.45Nm, loosely turn the mounting screws until initial contact is made with the shoulder of the lens mount. To access all the screws, you will need to rotate the PL locking ring, as some holes are obscured when the ring is either open or closed.

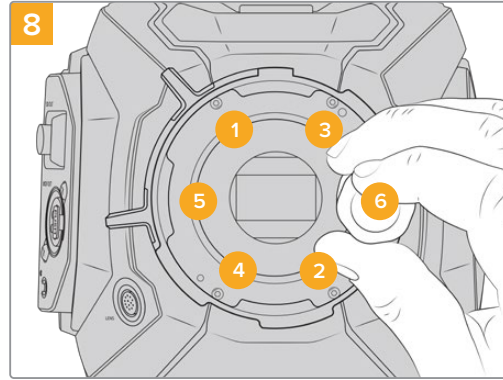

Confirm the lens mount is level and correctly aligned, then tighten the screws in the order shown here to an even pressure without over-tightening the screws.

## Shimming URSA Mini Pro

Shimming URSA Mini Pro is almost the same as URSA Mini PL. The only difference is the shape of the shims themselves. To shim your URSA Mini Pro, simply remove the attached lens mount, and add or remove shims as you would for URSA Mini PL, then replace the mount.

See the 'Interchangeable lens mount' section for more information on attaching lens mounts to URSA Mini Pro.

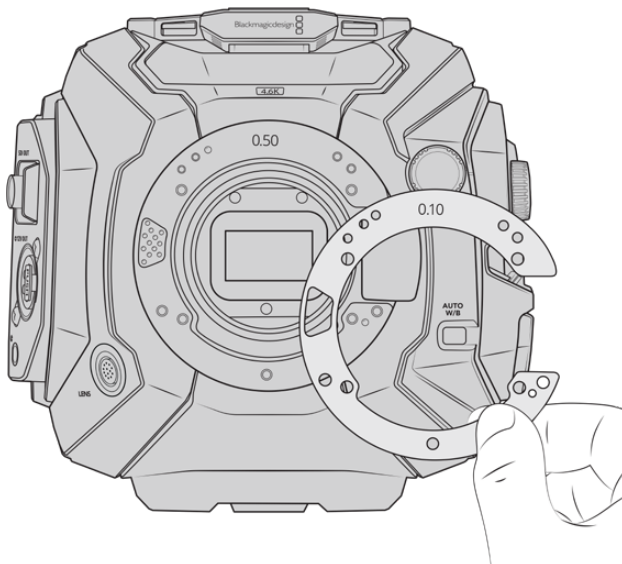

URSA Mini Pro's shims are C shaped to accommodate the lens release mechanism in the EF mount. This makes them easier to align as they can only fit one way. Installation is otherwise identical to URSA Mini PL.



## URSA Mini Recorder

Blackmagic URSA Mini Recorder is an optional module which attaches to the rear of URSA Mini Pro 12K. This recorder allows you to record footage, including 12K Blackmagic RAW files, to high capacity and inexpensive solid state drives, or 'SSDs'.

**NOTE** URSA Mini Recorder is designed for use with URSA Mini Pro 12K and is compatible with URSA Mini Pro 4.6K G2. It is not compatible with URSA Mini Pro 4.6K, URSA Mini 4.6K and URSA Mini 4K.

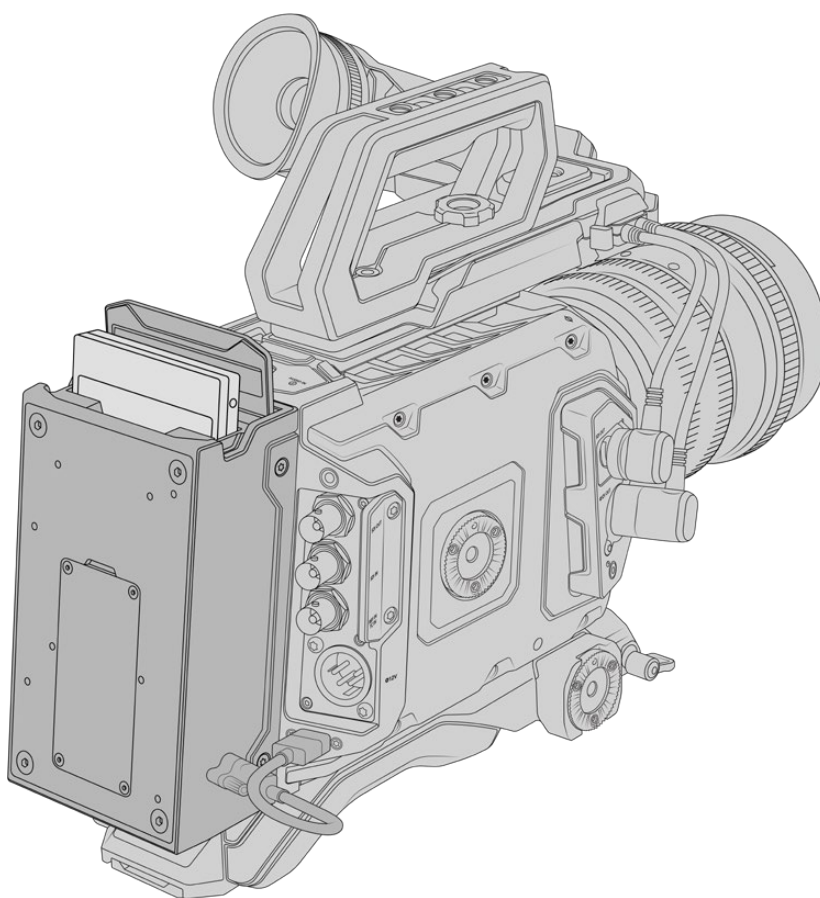

**When attaching URSA Mini Recorder, you will need the following tools:**

- 1 x phillips head screwdriver
- 1 x T10 torx screwdriver
- 1 x 2mm hex key driver



To attach the URSA Mini SSD Recorder to your URSA Mini you will need a large phillips head screwdriver , a T10 torx driver, and a 2mm hex key driver

## Mounting and connecting URSA Mini Recorder

URSA Mini Recorder mounts to the back of URSA Mini directly behind the camera body, using your camera's rear USB-C data port to pass data to and from URSA Mini Recorder.

**TIP** URSA Mini Recorder features a passthrough cable for your camera's battery power supply, so you can attach V-mount or gold mount batteries to the rear of the camera behind the recorder.

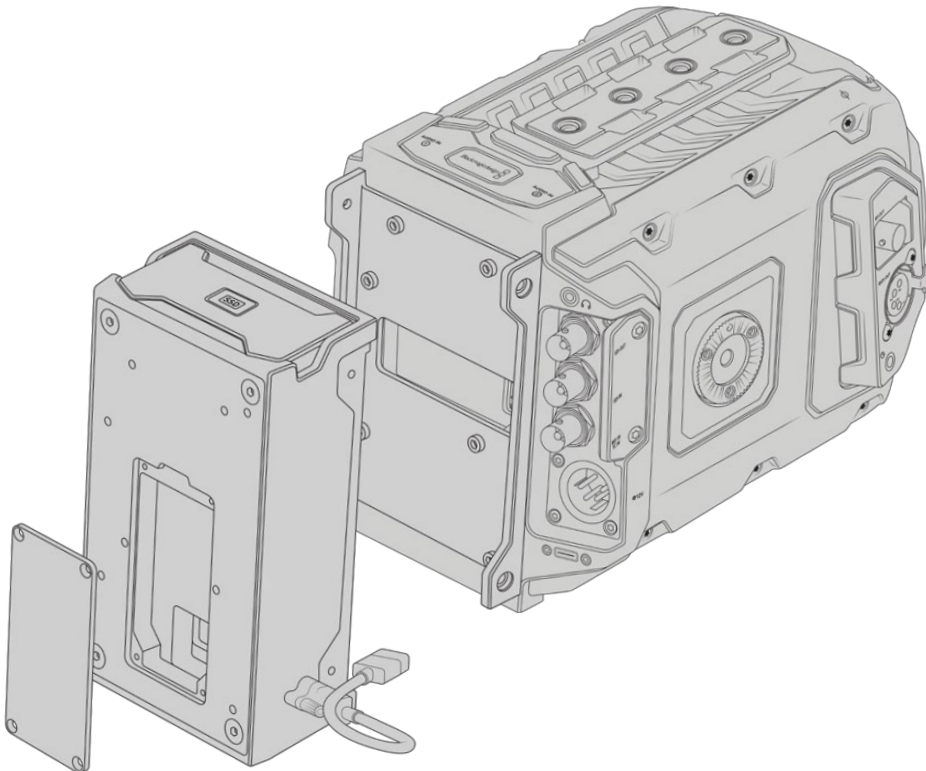

To mount and connect URSA Mini Recorder:

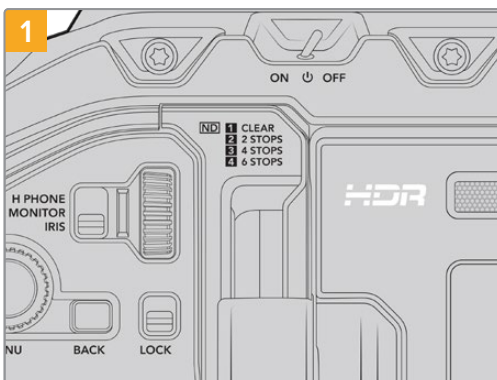

1 Power off URSA Mini Pro by moving the 'power' switch to 'off'.

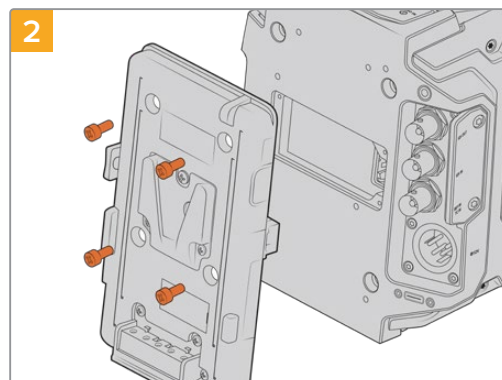

2 Unmount any battery plates currently fitted to your camera. For more information on mounting and unmounting battery plates, see the section 'mounting batteries' in this manual.



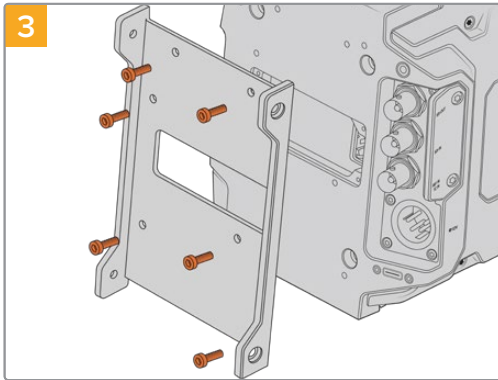

3 Attach URSA Mini Recorder's mounting bracket using 6 x T10 torx screws.

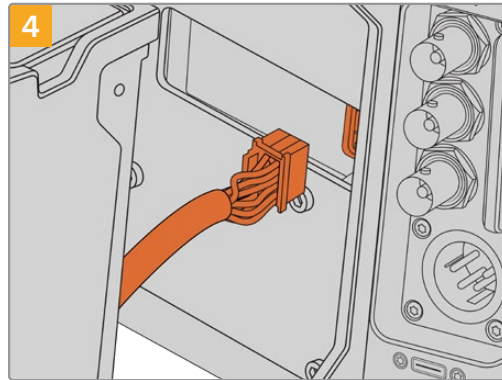

4 Plug the molex connector on URSA Mini Recorder into the molex socket on your camera's rear panel.

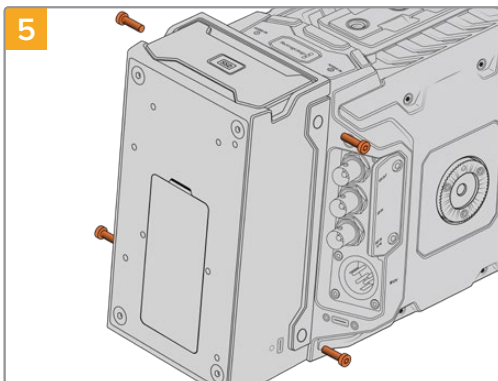

5 Attach URSA Mini Recorder to the mounting bracket using 2 x T10 torx screws on the left and right side of the brackets.

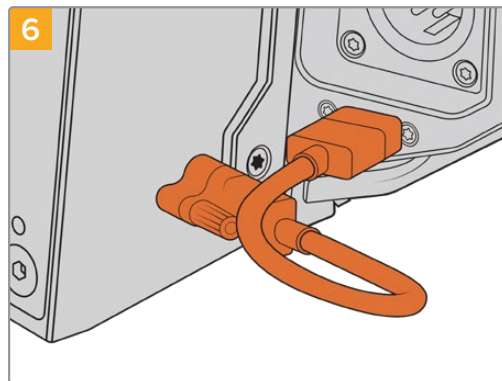

6 Connect the Mini Recorder's USB-C cable to the USB-C data port on the rear of URSA Mini Pro 12K. Tighten the locking connectors with your fingers, or use a 2mm hex key driver. To use with URSA Mini Pro 4.6K G2, use a longer USB-C cable and connect it to the USB-C port above the CFast slots.

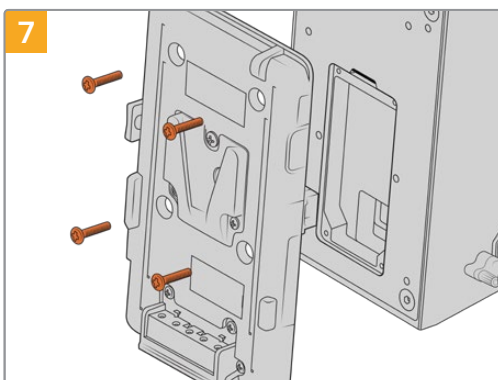

7 If you want to use a battery plate with URSA Mini Recorder, use a 2mm hex key driver to remove the four M3 screws holding the molex socket cover panel in place. Once the molex socket is uncovered, attach a battery plate using the steps outlined in the section 'mounting batteries' in this manual.

## Using URSA Mini Recorder

When URSA Mini Recorder is connected and an SSD is loaded, the recorder takes over from URSA Mini's number '2' storage slot. You'll see an 'SSD' indicator over slot 2 on your camera's storage manager when URSA Mini Recorder is in use.

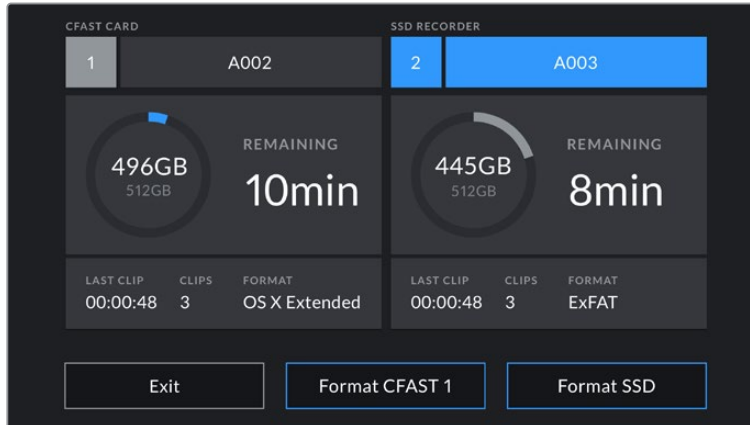

When an SSD is inserted into URSA Mini Recorder, your camera's storage manager will display 'SSD Recorder' over storage slot 2.

This means that recording, playback and storage management is exactly the same for SSDs as it is for CFast or SD cards. For general information on storage management, as well as specific instructions for choosing SSDs, see the 'storage media' section of this manual.

### Status LEDs

URSA Mini Recorder has one status light on the left side for 'SSD.' The brightness of this indicator can be set to 'low,' 'medium,' 'high' or 'off' in your camera's 'setup' menu.

### SSD

The 'SSD' indicator shows the status of the SSD currently inserted. This LED provides the following status indicators:

<b>Green</b>	Your URSA Mini Recorder will show a short green light when you insert an SSD into it. This is shown while it is verifying the SSD. When the indicator turns off your SSD Recorder is ready to record. The status light will also be green while footage is being played back from the SSD.
<b>Red</b>	Your URSA Mini Recorder will show a red light while it is recording to SSD. When the space on your SSD is running low the red light will begin to flash slowly. A fast flashing red light indicates that SSD is dropping frames. If this happens please check that you are using a disk from our recommended list of SSDs and that you are recording at a data rate that is compatible with your media.
<b>Orange</b>	If a problem has occurred while mounting the SSD the status light will go Orange. This may be the result of an improperly formatted or incompatible SSD. See the 'storage media' section in this manual for a list of compatible SSDs and formatting instructions.

**TIP** If the 'SSD' LED indicates a drive mounting error it may need to be 'initialized' on a mac or PC using disk utility or disk management.

## Updating URSA Mini Recorder's internal software

Update your URSA Mini Recorder using the Blackmagic Camera Setup Utility software. The Mini Recorder will need to be powered when updating, so we recommend keeping the Mini Recorder connected to URSA Mini Pro 12K during the update process. This also means your camera will need to supply consistent power, so be sure to plug into external power or battery pack.

Connect your computer to the Mini Recorder with a USB-C cable and launch Blackmagic Camera Setup Utility. You will be prompted to update if your computer detects that your URSA Mini Recorder is using outdated version. Follow the on screen prompts to update your URSA Mini Recorder's internal software.

**NOTE** Refer to the 'Blackmagic Camera Setup Utility' section in this manual for more information.

**TIP** We recommend updating all your Blackmagic URSA equipment at the same time for optimized performance.

# Help

The fastest way to obtain help is to go to the Blackmagic Design online support pages and check the latest support material available for your camera.

## Blackmagic Design Online Support Pages

The latest manual, software and support notes can be found at the Blackmagic Design support center at [www.blackmagicdesign.com/support](http://www.blackmagicdesign.com/support).

## Contacting Blackmagic Design Support

If you can't find the help you need in our support material, please use the 'Send us an email' button on the support page to email a support request. Alternatively, click on the 'Find your local support team' button on the support page and call your nearest Blackmagic Design support office.

## Checking the Software Version Currently Installed

To check which version of Blackmagic Camera Utility software is installed on your computer, open the About Blackmagic Camera Utility window.

- On Mac, open Blackmagic Camera Utility from the Applications folder. Select About Blackmagic Camera Utility from the application menu to reveal the version number.
- On Windows, open Blackmagic Camera Utility from your Start menu or Start Screen. Click on the Help menu and select About Blackmagic Camera Utility to reveal the version number.

## How to Get the Latest Software Updates

After checking the version of Blackmagic Camera Utility software installed on your computer, please visit the Blackmagic Design support center at [www.blackmagicdesign.com/support](http://www.blackmagicdesign.com/support) to check for the latest updates. While it is usually a good idea to run the latest updates, it is wise to avoid updating any software if you are in the middle of an important project.

# Regulatory Notices



## **Disposal of Waste of Electrical and Electronic Equipment Within the European Union.**

The symbol on the product indicates that this equipment must not be disposed of with other waste materials. In order to dispose of your waste equipment, it must be handed over to a designated collection point for recycling. The separate collection and recycling of your waste equipment at the time of disposal will help conserve natural resources and ensure that it is recycled in a manner that protects human health and the environment. For more information about where you can drop off your waste equipment for recycling, please contact your local city recycling office or the dealer from whom you purchased the product.



This equipment has been tested and found to comply with the limits for a Class A digital device, pursuant to Part 15 of the FCC rules. These limits are designed to provide reasonable protection against harmful interference when the equipment is operated in a commercial environment. This equipment generates, uses, and can radiate radio frequency energy and, if not installed and used in accordance with the instructions, may cause harmful interference to radio communications. Operation of this product in a residential area is likely to cause harmful interference, in which case the user will be required to correct the interference at personal expense.

The operation of this equipment is subject to the following two conditions:

- 1 This equipment or device may not cause harmful interference.
- 2 This equipment or device must accept any interference received, including interference that may cause undesired operation.



MSIP-REM-BMD-201511002  
MSIP-REM-BMD-201608001  
MSIP-REM-BMD-201703001  
R-R-BMD-201907006  
R-R-BMD-20200421001  
R-R-BMD-20200421002



## **ISED Canada Statement**

This device complies with Canadian standards for Class A digital apparatus.

Any modifications or use of this product outside its intended use could void compliance to these standards.

Connection to HDMI interfaces must be made with high quality shielded HDMI cables.

This equipment has been tested for compliance with the intended use in a commercial environment. If the equipment is used in a domestic environment, it may cause radio interference.

## **Bluetooth®**

The product is a Bluetooth wireless technology enabled product.

Contains transmitter module FCC ID: QOQBGM113

This equipment complies with FCC radiation exposure limits set forth for an uncontrolled environment.

Contains transmitter module IC: 5123A-BGM113

This device complies with Industry Canada's license-exempt RSS standards and exception from routine SAR evaluation limits given in RSS-102 Issue 5.

Certified for Japan, certificate number: 209-J00204. This equipment contains specified radio equipment that has been certified to the technical regulation conformity certification under the radio law.

This module has certification in South Korea, KC certification number: MSIP-CRM-BGT-BGM113

Hereby, Blackmagic Design declares that the product is using wideband transmission systems in 2.4 GHz ISM band is in compliance with directive 2014/53/EU.

The full text of the EU declaration of conformity is available from [compliance@blackmagicdesign.com](mailto:compliance@blackmagicdesign.com)

## Safety Information

The supplied AC to 12V DC power supply for Blackmagic URSA Mini, URSA Mini Pro and the IEC power cable for Blackmagic Studio Fiber Converter, must be connected to a mains socket outlet with a protective earth connection.

Blackmagic URSA Mini, URSA Mini Pro and Camera Fiber Converter are suitable for use in tropical locations with an ambient temperature of up to 40°C. Blackmagic Studio Fiber Converter is suitable for use in tropical locations with an ambient temperature of up to 50°C

Ensure that adequate ventilation is provided around the Blackmagic Studio Fiber Converter and Camera Fiber Converter so that ventilation is not restricted. When rack mounting the Studio Fiber Converter, ensure that the ventilation is not restricted by adjacent equipment.

No operator serviceable parts inside Blackmagic URSA Mini, URSA Mini Pro, Camera Fiber Converter or Studio Fiber Converter. Refer servicing to your local Blackmagic Design service center.

### State of California statement

This product can expose you to chemicals such as trace amounts of polybrominated biphenyls within plastic parts, which is known to the state of California to cause cancer and birth defects or other reproductive harm.

For more information go to [www.P65Warnings.ca.gov](http://www.P65Warnings.ca.gov).

### Blackmagic URSA Mini and URSA Mini Pro

During sunny conditions, consider shading of the camera to prevent exposure of the camera or Lithium battery to extended periods of sunlight. Keep Lithium batteries away from all sources of heat.

The 12V DC output connector is suitable to provide power to the Blackmagic URSA Viewfinder or Blackmagic URSA Studio Viewfinder. When connecting other accessories to this connector, ensure that the power consumption is less than 18W.

### Blackmagic Studio Fiber Converter



To reduce the risk of electric shock, do not expose this equipment to dripping or splashing. Use only at altitudes not more than 2000m above sea level.

### Blackmagic Camera Fiber Converter

Only use the converter when connected to the Blackmagic Studio Fiber Converter. Under normal use, the converter is designed to receive hazardous voltages from the Blackmagic Studio Fiber Converter.

# Warranty

## Limited Warranty

Blackmagic Design warrants that this product will be free from defects in materials and workmanship for a period of 12 months from the date of purchase. If a product proves to be defective during this warranty period, Blackmagic Design, at its option, either will repair the defective product without charge for parts and labor, or will provide a replacement in exchange for the defective product.

In order to obtain service under this warranty, you the Customer, must notify Blackmagic Design of the defect before the expiration of the warranty period and make suitable arrangements for the performance of service. The Customer shall be responsible for packaging and shipping the defective product to a designated service center nominated by Blackmagic Design, with shipping charges pre paid. Customer shall be responsible for paying all shipping charges, insurance, duties, taxes, and any other charges for products returned to us for any reason.

This warranty shall not apply to any defect, failure or damage caused by improper use or improper or inadequate maintenance and care. Blackmagic Design shall not be obliged under this warranty: a) to repair damage resulting from attempts by personnel other than Blackmagic Design representatives to install, repair or service the product, b) to repair damage resulting from improper use or connection to incompatible equipment, c) to repair any damage or malfunction caused by the use of non Blackmagic Design parts or supplies, or d) to service a product that has been modified or integrated with other products when the effect of such a modification or integration increases the time or difficulty of servicing the product.

Exposing URSA Viewfinder to direct sunlight could damage the viewfinder display as the viewfinder optics act as a magnifying glass. Image retention or burn-in could happen on OLED panels when static or high contrast images, such as frame guides, are displayed on the panels for extended periods. To avoid this, ensure the IR sensor for face detection is not covered deliberately and disconnect the viewfinder when not in use for prolonged periods. Image retention is not covered by this product warranty.

THIS WARRANTY IS GIVEN BY BLACKMAGIC DESIGN IN LIEU OF ANY OTHER WARRANTIES, EXPRESS OR IMPLIED. BLACKMAGIC DESIGN AND ITS VENDORS DISCLAIM ANY IMPLIED WARRANTIES OF MERCHANTABILITY OR FITNESS FOR A PARTICULAR PURPOSE. BLACKMAGIC DESIGN'S RESPONSIBILITY TO REPAIR OR REPLACE DEFECTIVE PRODUCTS DURING THE WARRANTY PERIOD IS THE WHOLE AND EXCLUSIVE REMEDY PROVIDED TO THE CUSTOMER. BLACKMAGIC DESIGN WILL NOT BE LIABLE FOR ANY INDIRECT, SPECIAL, INCIDENTAL OR CONSEQUENTIAL DAMAGES IRRESPECTIVE OF WHETHER BLACKMAGIC DESIGN OR THE VENDOR HAS ADVANCE NOTICE OF THE POSSIBILITY OF SUCH DAMAGES. BLACKMAGIC DESIGN IS NOT LIABLE FOR ANY ILLEGAL USE OF EQUIPMENT BY CUSTOMER. BLACKMAGIC IS NOT LIABLE FOR ANY DAMAGES RESULTING FROM USE OF THIS PRODUCT. USER OPERATES THIS PRODUCT AT OWN RISK.

© Copyright 2020 Blackmagic Design. All rights reserved. 'Blackmagic Design', 'URSA', 'DeckLink', 'HDLink', 'Workgroup Videohub', 'Multibrige Pro', 'Multibrige Extreme', 'Intensity' and 'Leading the creative video revolution' are registered trademarks in the US and other countries. All other company and product names may be trademarks of the respective companies with which they are associated.

The Bluetooth® word mark and logos are registered trademarks owned by Bluetooth SIG, Inc. and any use of such marks by Blackmagic Design is under license. Other trademarks and trade names are those of the respective owners.