

CHANNEL	VALUE	FUNCTION
		AUTO
	0 ↔ 40	NO FUNCTION
	41 ↔ 50	ATUO1
	51 ↔ 60	ATUO2
	61 ↔ 70	ATUO3
	71 ↔ 80	ATUO4
	81 ↔ 90	ATUO5
	91 ↔ 100	ATUO6
	101 ↔ 110	ATUO7
	111 ↔ 120	ATUO8
13	121 ↔ 130	ATUO9
	131 ↔ 140	ATUO10
	141 ↔ 150	PROGRAM1
	151 ↔ 160	PROGRAM2
	161 ↔ 170	PROGRAM3
	171 ↔ 180	PROGRAM4
	181 ↔ 190	PROGRAM5
	191 ↔ 200	PROGRAM6
	201 ↔ 210	PROGRAM7
	211 ↔ 220	PROGRAM8
	221 ↔ 230	PROGRAM9
	231 ↔ 255	PROGRAM10
14	0 ↔ 255	AUTO SPEED ADJUSTMENT
15	0 ↔ 255	ZOOM
	0 ↔ 200	NO FUNCTION
16	201 ↔ 220	ZOOM RESET
	221 ↔ 255	NO FUNCTION
		DIMMER SPEED
	0 ↔ 9	PRESET DIMMER SPEED FROM DISPLAY MENU
	10 ↔ 29	OFF
	30 ↔ 69	DIM1
17	70 ↔ 129	DIM2
	130 ↔ 189	DIM3
	190 ↔ 255	DIM4

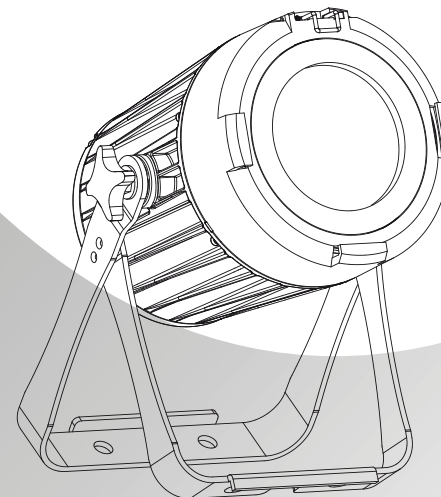

USER MANUAL



ICOLOR60Z

1 PRODUCT SPECIFICATIONS

1.1 PRODUCT SPECIFICATIONS

- ◆ Voltage: AC100~240V, 50/60Hz
- ◆ Max Power: 85W
- ◆ Operation Temperature: -20°C~45°C
- ◆ Size: 348×176×242mm
- ◆ Weight: 5.4kg

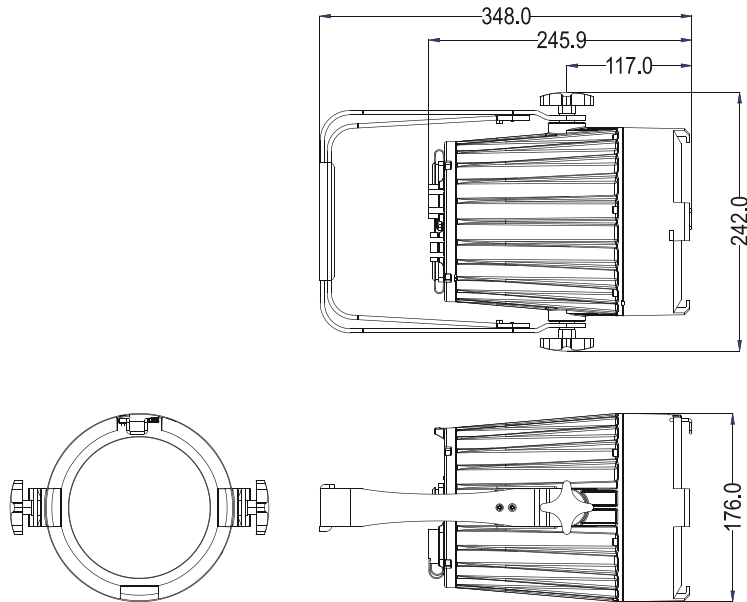

TR16		
CHANNEL	VALUE	FUNCTION
1	0 ⇄ 255	MASTER DIMMER
2	0 ⇄ 255	MASTER DIMMER FINE
3	0 ⇄ 255	RED
4	0 ⇄ 255	RED FINE
5	0 ⇄ 255	GREEN
6	0 ⇄ 255	GREEN FINE
7	0 ⇄ 255	BLUE
8	0 ⇄ 255	BLUE FINE
9	0 ⇄ 255	WHITE
10	0 ⇄ 255	WHITE FINE
		COLOR MARCOS
	0 ⇄ 10	NO FUNCTION
	11 ⇄ 30	RED 100% / GREEN UP / BLUE 0%
	31 ⇄ 50	RED DOWN / GREEN 100% / BLUE 0%
	51 ⇄ 70	RED 0% / GREEN 100% / BLUE UP
	71 ⇄ 90	RED 0% / GREEN DOWN / BLUE 100%
	91 ⇄ 110	RED UP / GREEN 0% / BLUE 100%
	111 ⇄ 130	RED 100% / GREEN 0% / BLUE DOWN
	131 ⇄ 150	RED 100% / GREEN UP / BLUE UP
	151 ⇄ 170	RED DOWN / GREEN DOWN / BLUE 100%
	171 ⇄ 195	ALL LEDS AT FULL OUTPUT
11	196 ⇄ 200	2700K
	201 ⇄ 205	3000K
	206 ⇄ 210	3200K
	211 ⇄ 215	3500K
	216 ⇄ 220	4000K
	221 ⇄ 225	4200K
	226 ⇄ 230	4500K
	231 ⇄ 235	5600K
	236 ⇄ 240	6000K
	241 ⇄ 245	6500K
	246 ⇄ 250	7200K
	251 ⇄ 255	8000K
		STROBE
	0 ⇄ 9	NO FUNCTION
12	10 ⇄ 99	STROBE FROM (SLOW TO FAST , 0-25Hz)
	100 ⇄ 109	NO FUNCTION
	110 ⇄ 179	LIGHTNING STROBE
	180 ⇄ 189	NO FUNCTION
	190 ⇄ 255	RANDOM SROBE

1.2 SAFETY WARNING

CHANNEL	VALUE	FUNCTION
8		AUTO
	0 ↔ 40	NO FUNCTION
	41 ↔ 50	ATUO1
	51 ↔ 60	ATUO2
	61 ↔ 70	ATUO3
	71 ↔ 80	ATUO4
	81 ↔ 90	ATUO5
	91 ↔ 100	ATUO6
	101 ↔ 110	ATUO7
	111 ↔ 120	ATUO8
	121 ↔ 130	ATUO9
	131 ↔ 140	ATUO10
	141 ↔ 150	PROGRAM1
	151 ↔ 160	PROGRAM2
	161 ↔ 170	PROGRAM3
	171 ↔ 180	PROGRAM4
	181 ↔ 190	PROGRAM5
	191 ↔ 200	PROGRAM6
	201 ↔ 210	PROGRAM7
	211 ↔ 220	PROGRAM8
221 ↔ 230	PROGRAM9	
231 ↔ 255	PROGRAM10	
9	0 ↔ 255	AUTO SPEED ADJUSTMENT
10	0 ↔ 255	ZOOM
11	0 ↔ 200	NO FUNCTION
	201 ↔ 220	ZOOM RESET
	221 ↔ 255	NO FUNCTION
12		DIMMER SPEED
	0 ↔ 9	PRESET DIMMER SPEED FROM DISPLAY MENU
	10 ↔ 29	OFF
	30 ↔ 69	DIM1
	70 ↔ 129	DIM2
	130 ↔ 189	DIM3
	190 ↔ 255	DIM4

IMPORTANT:

- This product must be installed by a qualified professional.
- All maintenance must be carried out by a qualified electrician.
- A minimum distance of 0.5m must be maintained between the equipment and a combustible surface.
- The product must always be operated in a well ventilated area.
- DO NOT stare directly into the LED light source.
- Always disconnect the power before carrying out any maintenance.
- The earth must always be connected to the ground.
- Ensure that all parts of the equipment are kept clean and free of dust.

2 INSTALLATION

2.1 MOUNTING

HANGING

The fixture can be mounted in a hanging position using the supporting bracket. The bracket should be secured to the mounting truss or structure using a standard mounting clamp. Please note that when hanging the unit a safety cable should also be used.

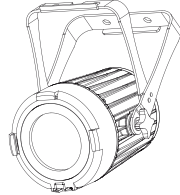

UPRIGHT

The fixture can be mounted in an upright or sitting position using the supporting brackets.

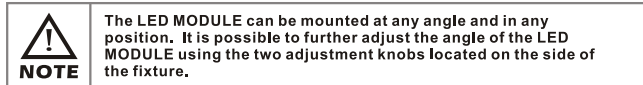
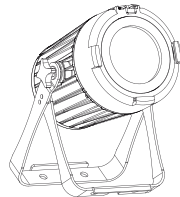

2.2 POWER CONNECTIONS

@ 220V: 20 units may be connected in series

@ 110V: 10 units may be connected in series

Note:

If the signal cable is over 60m between the DMX512 controller and fixture or between two fixtures, then a DMX signal amplifier is needed as well.

TOUR		
CHANNEL	VALUE	FUNCTION
1	0 ↔ 255	MASTER DIMMER
2	0 ↔ 255	RED
3	0 ↔ 255	GREEN
4	0 ↔ 255	BLUE
5	0 ↔ 255	WHITE
		COLOR MARCOS
	0 ↔ 10	NO FUNCTION
	11 ↔ 30	RED 100% / GREEN UP / BLUE 0%
	31 ↔ 50	RED DOWN / GREEN 100% / BLUE 0%
	51 ↔ 70	RED 0% / GREEN 100% / BLUE UP
	71 ↔ 90	RED 0% / GREEN DOWN / BLUE 100%
	91 ↔ 110	RED UP / GREEN 0% / BLUE 100%
	111 ↔ 130	RED 100% / GREEN 0% / BLUE DOWN
	131 ↔ 150	RED 100% / GREEN UP / BLUE UP
	151 ↔ 170	RED DOWN / GREEN DOWN / BLUE 100%
	171 ↔ 195	ALL LEDS AT FULL OUTPUT
6	196 ↔ 200	2700K
	201 ↔ 205	3000K
	206 ↔ 210	3200K
	211 ↔ 215	3500K
	216 ↔ 220	4000K
	221 ↔ 225	4200K
	226 ↔ 230	4500K
	231 ↔ 235	5600K
	236 ↔ 240	6000K
	241 ↔ 245	6500K
	246 ↔ 250	7200K
	251 ↔ 255	8000K
		STROBE
	0 ↔ 9	NO FUNCTION
	10 ↔ 99	STROBE FROM (SLOW TO FAST , 0-25Hz)
7	100 ↔ 109	NO FUNCTION
	110 ↔ 179	LIGHTNING STROBE
	180 ↔ 189	NO FUNCTION
	190 ↔ 255	RANDOM SROBE

SSP		
CHANNEL	VALUE	FUNCTION
1	0 ↔ 255	MASTER DIMMER
2	0 ↔ 255	RED
3	0 ↔ 255	GREEN
4	0 ↔ 255	BLUE
5	0 ↔ 255	WHITE
6		STROBE
	0 ↔ 9	NO FUNCTION
	10 ↔ 99	STROBE FROM (SLOW TO FAST , 0-25Hz)
	100 ↔ 109	NO FUNCTION
	110 ↔ 179	LIGHTNING STROBE
	180 ↔ 189	NO FUNCTION
7	190 ↔ 255	RANDOM SROBE
	0 ↔ 255	ZOOM
8	0 ↔ 200	NO FUNCTION
	201 ↔ 220	ZOOM RESET
	221 ↔ 255	NO FUNCTION
9		DIMMER SPEED
	0 ↔ 9	PRESET DIMMER SPEED FROM DISPLAY MENU
	10 ↔ 29	OFF
	30 ↔ 69	DIM1
	70 ↔ 129	DIM2
	130 ↔ 189	DIM3
	190 ↔ 255	DIM4

3 DISPLAY PANEL OPERATION

3.1 DISPLAY OPERATION

- ◆ MENU: BACK;
- ◆ ENTER: ENTER OR SAVE;
- ◆ DOWN: DOWN;
- ◆ UP: UP;

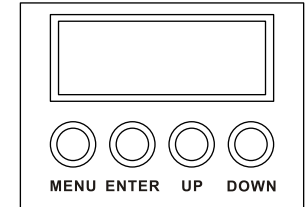

3.2 MENU MAP

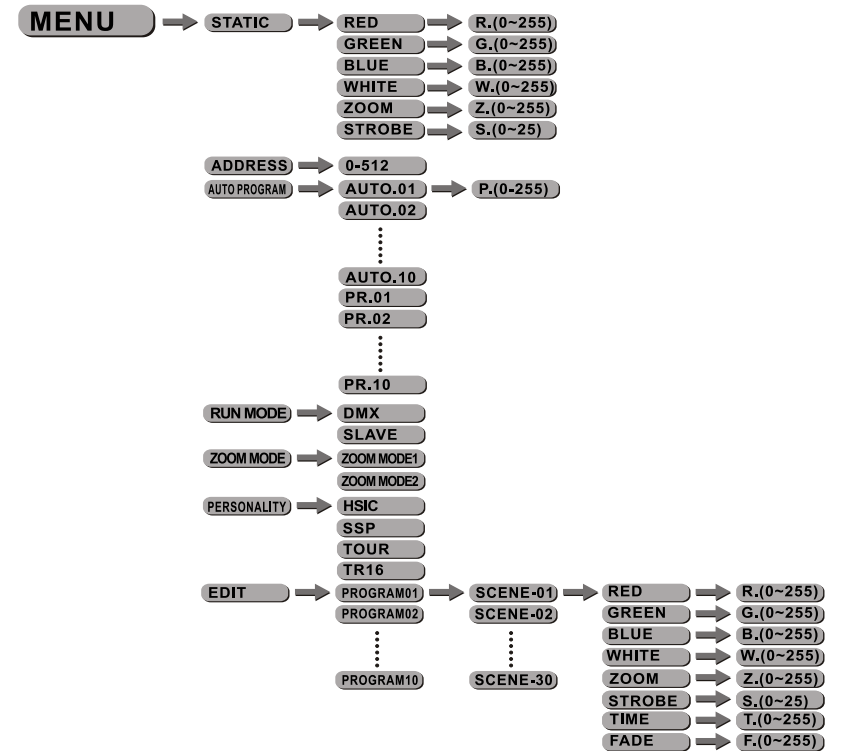

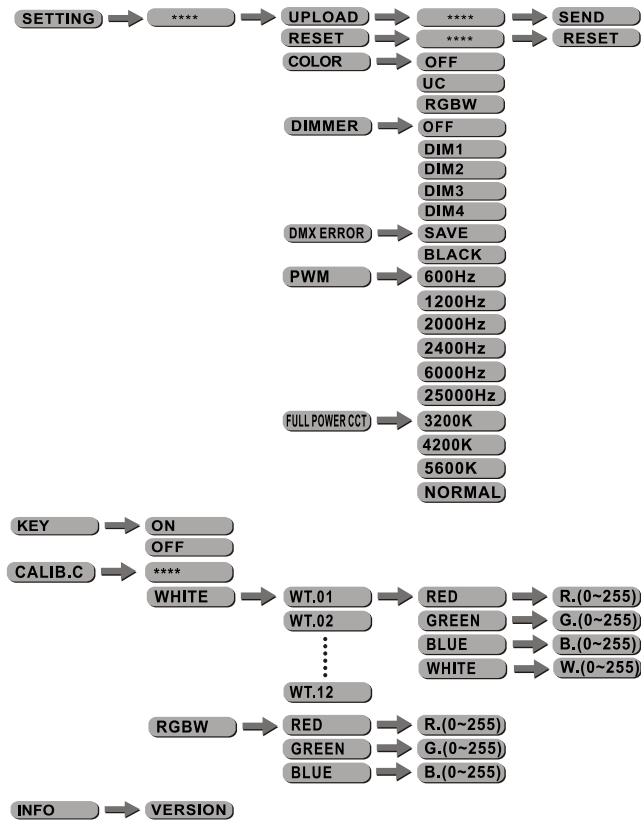

4 USING A DMX512 CONTROLLER

4.1 CHANNEL ASSIGNMENT

- Note: This product have four DMX512 channel configuration: **【HSIC】**, **【SSP】**, **【TOUR】**, **【TR16】**.

HSIC		
CHANNEL	VALUE	FUNCTION
1	0 ⇔ 255	INTENSITY
2	0 ⇔ 255	HUE
3	0 ⇔ 255	HUE FINE
4	0 ⇔ 255	SATURATION
5		CCT
	0 ⇔ 10	NO FUNCTION
	11 ⇔ 30	2700K
	31 ⇔ 50	3000K
	51 ⇔ 70	3200K
	71 ⇔ 90	3500K
	91 ⇔ 110	4000K
	111 ⇔ 130	4200K
	131 ⇔ 150	4500K
	151 ⇔ 170	5600K
	171 ⇔ 190	6000K
	191 ⇔ 210	6500K
	211 ⇔ 230	7200K
231 ⇔ 255	8000K	
6		STROBE
	0 ⇔ 9	NO FUNCTION
	10 ⇔ 99	STROBE FROM (SLOW TO FAST , 0-25Hz)
	100 ⇔ 109	NO FUNCTION
	110 ⇔ 179	LIGHTNING STROBE
	180 ⇔ 189	NO FUNCTION
	190 ⇔ 255	RANDOM SROBE
7	0 ⇔ 255	ZOOM
8	0 ⇔ 200	NO FUNCTION
	201 ⇔ 220	ZOOM RESET
	221 ⇔ 255	NO FUNCTION
9		DIMMER SPEED
	0 ⇔ 9	PRESET DIMMER SPEED FROM DISPLAY MENU
	10 ⇔ 29	OFF
	30 ⇔ 69	DIM1
	70 ⇔ 129	DIM2
9	130 ⇔ 189	DIM3
	190 ⇔ 255	DIM4

3.11 ACTIVATE THE PASSWORD



- Enter the **【KEY】** mode to select whether the access password is on or off.
- When the fixture is set as PASS **【ON】** , after 30 seconds or turn on the fixture next time, the fixture will need an access password to enter the display menu control.

Note: The factory access password is **【UP】 + 【DOWN】 + 【UP】 + 【DOWN】** , then press **【ENTER】** to confirm the access.

3.12 BALANCE PARAMETERS AND CORRECTION MENU DISPLAY

Press **【MENU】** button to enter the password confirmation, to enter the correct password < UP + DOWN + UP + DOWN >
Key, press the **【MENU】** in, the correct password will enter show submenu

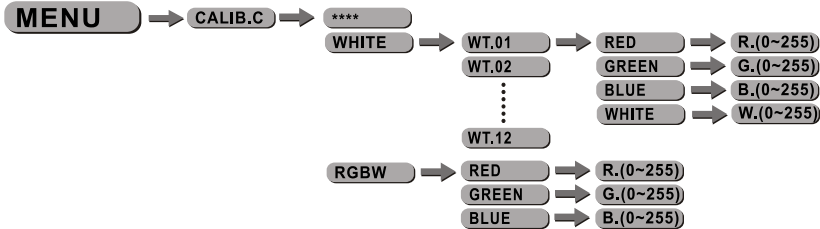

- Enter the **【CALIB.C】** to select white color of different color temperature.
 - There are 12 pre-programmed White colors can be edited by using **【RED】** , **【GREEN】** , **【BLUE】** & **【WHITE】** .
 - When DMX mode is HSIC, CH5 can play 12 white color
 - When DMX mode is TOUR, CH6 can play 12 white color
 - When DMX mode is TR16, CH11 can play 12 white color
- Note: if CCT data is changed in **【WHITE】** from WT.01 to WT.12, CCT of according channel will be changed also
- Enter the **【RGBW】** to adjust the RGB parameter to make different whites.
 - When the new setting is activated, the DMX controller choose RGB = 255,255,255 the white color will be made by the actual RGB values on the **【RGBW】** .

3.13 INFO



- Press **【ENTER】** and go to **【INFO】** ,you can check **【VERSION】** .

3.3 EDIT STATIC COLOUR

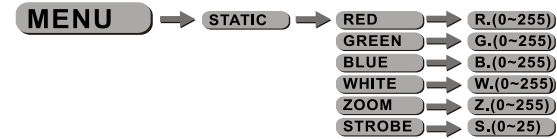

- Combine **【RED】** , **【GREEN】** , **【BLUE】** , **【WHITE】** AND **【ZOOM】** to create an infinite range of colors (0-255)
- Set the value of the **【STROBE】** (0-25Hz)

3.4 DMX512 SETTINGS



- Enter the **【ADDRESS】** mode to set the DMX ADDRESS.

3.5 ACTIVATING AUTO PROGRAMS

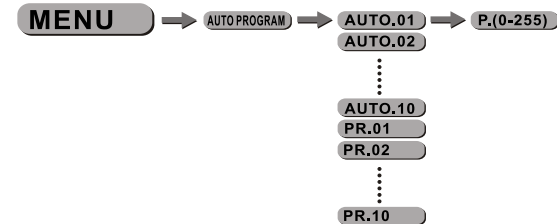

- Select the target **【AUTO PROGRAM】** program and press **【ENTER】** .
- Programs **【AUTO.01】** to **【AUTO.10】** are fully pre-programmed and will not be altered by changes in **【EDIT】** mode.
- Programs **【PR.01】** to **【PR.10】** are fully pre-programmed and can be edited in **【EDIT】** mode.

3.6 RUN MODE



- Enter the **【RUN MODE】** mode to set working mode.
- **【DMX】** mode is for using the DMX512 controller to control the fixtures.
- **【SLAVE】** mode is for Master -- Slave operation.

3.7 ZOOM MODE

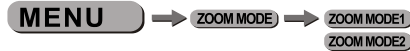

- **【ZOOM MODE 1】** is the default fast zoom speed, work in Ambient Temp. > 0°C
- **【ZOOM MODE 2】** is slow zoom speed, works in Ambient Temp. < 0°C

3.8 PERSONALITY

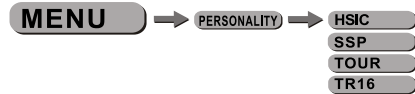

- Enter the **【PERSONALITY】** mode to select DMX mode: **【HSIC】 \ 【SSP】 \ 【TOUR】 \ 【TR16】** .

Introduction for HSIC

- **HUE**: colorful present(red, orange,yellow, green,cyan, blue, magentacolor changeable)
- **HUE FINE**: fine dimming when choose a color
- **SATURATION**: adjust saturation when choose a color
- **INTENSITY**: adjust intensity for chosen color
- **CCT**: choose needed color temperature(2700k, 3000k, 3200k, 3500k, 4000k, 4200k, 4500k, 5600k, 6000k, 6500k, 7200k, 8000k)

3.9 EDITING CUSTOM PROGRAMS

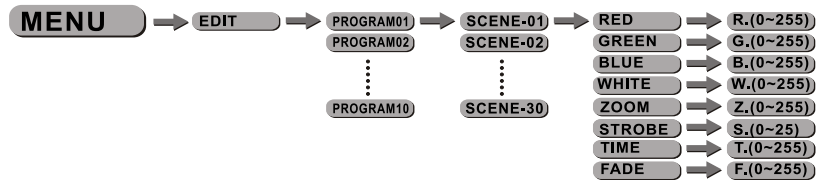

- Enter the **【EDIT】** mode to edit the custom programs **【PROGRAM01】** to **【PROGRAM10】** .
- Each custom program has 30 scenes that can be edited.
- Each step allows the creation of a scene using RED **【RED】** , GREEN **【GREEN】** , BLUE **【BLUE】** , WHITE **【WHITE】** , ZOOM **【ZOOM】** , STROBE **【STROBE】** ,TIME **【TIME】** & FADE **【FADE】** .

3.10 SPECIAL SETTINGS

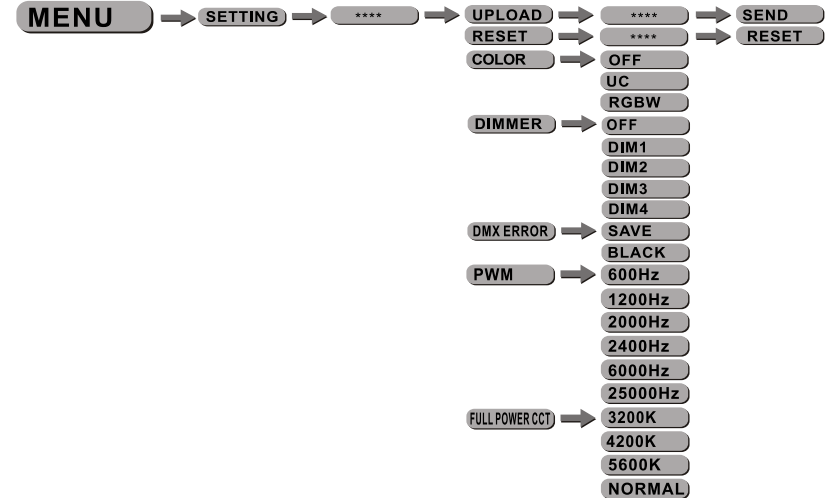

- **【SETTING】**...this menu allows the user to adjust key operation settings for this fixture.
- Select **【UPLOAD】** to upload the custom programs from the current MASTER unit to the SLAVE units.
- In order to reset custom modes to default values select **【RESET】** .
Note: **【UC】****【RGBW】****【CALIB.C】** can't reset
- **【COLOR】** is for activate/unactivate the color calibration functions. When **【RGBW】** is selected, on RGB = 255,255,255, the color is displayed as calibrated in CALIB.C -- RGBW. When **【COLOR】** is set **【OFF】** , on RGB = 255,255,255, the RGB values are not adjusted and the output is most powerful. When **【UC】** is selected, the RGB output are adjusted to a standard preset universal color which balances fixtures from different generations.
Note: **【COLOR】** work only when choose **【NORMAL】** at **【FULL POWER CCT】**
- Select **【DIM1】**, **【DIM2】**, **【DIM3】** or **【DIM4】** for different dimming speeds. (**【DIM4】** is the slowest dimming speed)
- **【DMX ERROR】** Choose **【SAVE】** in order to save the last DMX data in case of DMX signal error. Choose **【BLACK】** in order to blackout in case of DMX signal error.
- **<PWM_RATE>** is PWM refresh rate bottom, press UP/DOWN to choose **<600Hz>**、**<1200Hz>**、**<2000Hz>**、**<4000Hz>**、**<25000Hz>**
Note: with refresh rate increased, gray rate of dimmer will be reduced, (that's means high refresh rate, low gray rate), when it's **<4000Hz>**, CV3 is invalid, when it's **<25000Hz>**, CV1 CV2 CV3 are invalid, so please lower PWM rate to increase gray rate in necessary.
- **<FULL POWER CCT>** is the color temperature choose bottom, press UP/DOWN to choose, under full power, **<3200K>**、**<4200K>**、**<5600K>** can be chosen, when choose **<COLOR>**、**<3200K>**、**<4200K>**、**<5600K>** are not work, but choose **<NORMAL>** .