



## AU-DTI4-TX

Dante Transmitter with 4 Channels  
of Balanced Mono Inputs

**OPERATION MANUAL**



## **DISCLAIMERS**

The information in this manual has been carefully checked and is believed to be accurate. CYP (UK) Ltd assumes no responsibility for any infringements of patents or other rights of third parties which may result from its use.

CYP (UK) Ltd assumes no responsibility for any inaccuracies that may be contained in this document. CYP (UK) Ltd also makes no commitment to update or to keep current the information contained in this document.

CYP (UK) Ltd reserves the right to make improvements to this document and/or product at any time and without notice.

## **COPYRIGHT NOTICE**

No part of this document may be reproduced, transmitted, transcribed, stored in a retrieval system, or any of its part translated into any language or computer file, in any form or by any means—electronic, mechanical, magnetic, optical, chemical, manual, or otherwise—without express written permission and consent from CYP (UK) Ltd.

© Copyright 2021 by CYP (UK) Ltd.

All Rights Reserved.

Version 1.1

## **TRADEMARK ACKNOWLEDGMENTS**

All products or service names mentioned in this document may be trademarks of the companies with which they are associated.

---



## SAFETY PRECAUTIONS

Please read all instructions before attempting to unpack, install or operate this equipment and before connecting the power supply. Please keep the following in mind as you unpack and install this equipment:

- Always follow basic safety precautions to reduce the risk of fire, electrical shock and injury to persons.
- To prevent fire or shock hazard, do not expose the unit to rain, moisture or install this product near water.
- Never spill liquid of any kind on or into this product.
- Never push an object of any kind into this product through any openings or empty slots in the unit, as you may damage parts inside the unit.
- Do not attach the power supply cabling to building surfaces.
- Use only the supplied power supply unit (PSU). Do not use the PSU if it is damaged.
- Do not allow anything to rest on the power cabling or allow any weight to be placed upon it or any person walk on it.
- To protect the unit from overheating, do not block any vents or openings in the unit housing that provide ventilation and allow for sufficient space for air to circulate around the unit.
- Please completely disconnect the power when the unit is not in use to avoid wasting electricity.

## VERSION HISTORY

VERSION NO.	DATE	SUMMARY OF CHANGE
<b>v1.00</b>	15/02/2021	Preliminary release (RDV1)

# CONTENTS

<b>1. Introduction</b> .....	<b>1</b>
<b>2. Applications</b> .....	<b>1</b>
<b>3. Package Contents</b> .....	<b>1</b>
<b>4. System Requirements</b> .....	<b>2</b>
<b>5. Features</b> .....	<b>2</b>
<b>6. Operation Controls and Functions</b> .....	<b>3</b>
6.1 Front Panel .....	3
6.2 Rear Panel.....	3
6.3 RS-232 Pinout and Defaults .....	4
6.4 Audio Routing Control.....	4
6.5 Serial Commands (via USB) .....	5
<b>7. Connection Diagram</b> .....	<b>8</b>
<b>8. Specifications</b> .....	<b>9</b>
8.1 Technical Specifications .....	9
8.2 Audio Specifications.....	10
8.2.1 Digital Audio .....	10
8.2.2 Analogue Audio .....	10
8.3 Cable Specifications .....	10
<b>9. Acronyms</b> .....	<b>11</b>

---

## 1. INTRODUCTION

This 4-channel analogue audio to Dante output transmitter is easy to use and convenient to install. Thanks to the integrated support for Dante technology which extends and routes audio across standard Ethernet networks, this unit forms an important part of an easier and more flexible system for managing large audio systems than traditional point-to-point physical wiring. Dante does away with the bundles of heavy, expensive, multi-core analogue audio cables and replaces it with low cost, and easy to manage, Cat.5e or Cat.6 cables while maintaining the high quality expected from uncompressed digital audio. Due to the nature of packet-based Ethernet data transmission, there is no need to worry about the traditional enemies of long distance audio extension, such as analogue signal interference, crosstalk, or signal attenuation. All of this is provided with the absolute minimum of latency (typically around 1ms).

The unit is equipped with four analogue mono audio inputs and one Dante output port which can transmit up to 4 digital audio channels and is compatible with any standard Dante audio receivers that the audio might be routed to. Each audio input can optionally supply phantom power (5v or 48v) if needed by a connected audio source, such as a microphone. It is powered directly by PoE (Power over Ethernet) which allows for increased installation location flexibility. Basic device configuration is provided by serial over USB while routing and network configuration management is provided via 3rd party control software.

## 2. APPLICATIONS

- /// Home Theaters
- /// Classrooms
- /// Lecture Halls

## 3. PACKAGE CONTENTS

- /// 1× 4 Balanced In, Analogue Audio to Dante
- /// 4× 3-pin Terminal Block
- /// 1× Operation Manual

## 4. SYSTEM REQUIREMENTS

- /// An active network connection from a switch or router that supports PoE (802.3af) for extension of Dante audio and to power the unit.
- /// Analogue audio source equipment such as microphones, media players, or PCs/laptops.
- /// 3rd party control software, such as Dante Controller from Audinate, is required to configure and manage audio routes between Dante endpoints.

## 5. FEATURES

- /// One standard Dante output
- /// Four balanced analogue mono audio inputs
- /// Optional phantom power (5v or 48v) support on all inputs
- /// High quality ADC (Analogue to Digital audio Conversion) functionality with very low latency
- /// Compatible with existing Dante audio networks
- /// Powered directly by PoE (802.3af) provided by the network switch or router connected to the Dante port
- /// Simple and easy audio routing via 3rd party control software which is available for both Windows and macOS systems
- /// Basic device configuration via serial over USB

## 6. OPERATION CONTROLS AND FUNCTIONS

### 6.1 Front Panel

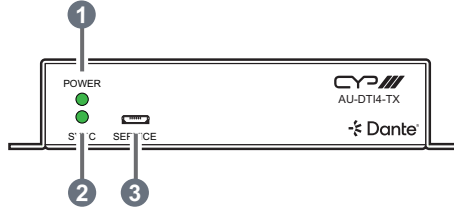

- 1 **POWER LED:** This LED will illuminate to indicate the unit is on and receiving power.
- 2 **SYNC LED:** This LED will illuminate to indicate the unit is actively connected to a valid Ethernet network.
- 3 **SERVICE Port (USB 2.0 Micro-B):** This port is used for serial control and firmware updates.

### 6.2 Rear Panel

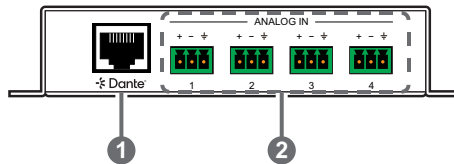

- 1 **DANTE Port:** Connect to a standard Ethernet network switch or router, which is hosting Dante audio receivers, with a single Cat.5e/6/7 cable for transmission and routing of all available audio inputs.

*Note: This unit is powered via PoE (802.3af) which must be supplied by the network switch or router connected to the Dante port.*

- 2 **Analogue IN 1~4 3-pin Terminal Blocks:** Connect to the analogue mono outputs of devices such as audio players, PCs or microphones.

*Note: Phantom power (5v or 48v) can be provided independently to each input. Control over this feature is only available via serial commands.*

## 6.3 RS-232 Pinout and Defaults

Serial Port Default Settings	
<b>Baud Rate</b>	19200
<b>Data Bits</b>	8
<b>Parity Bits</b>	None
<b>Stop Bits</b>	1
<b>Flow Control</b>	None

*Note: Serial control over this unit is available only via the USB Micro-B service port on the front of the unit. Connect the unit directly to the USB port on a PC or laptop and configure the virtual COM port to use the above settings.*

## 6.4 Audio Routing Control

Discovery of Dante hardware and control over the behavior and routing of Dante audio is managed via 3rd party control software or hardware. The simplest available option is the Dante Controller software which is freely available directly from Audinate ([www.audinate.com](http://www.audinate.com)). This is a fully software based solution for controlling multiple audio transmitters and receivers, in a variety of configurations, providing full and detailed control over the audio handling of each individual unit. The Dante Controller software is available for both Windows and macOS systems.

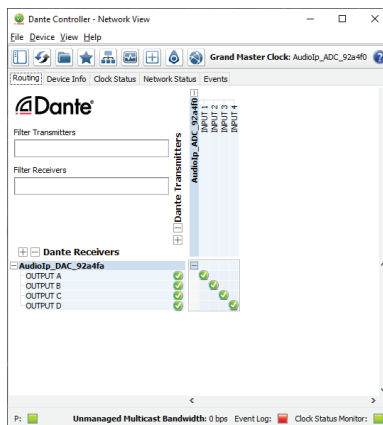

## 6.5 Serial Commands (via USB)

COMMAND
Description and Parameters
<p><b>help</b> ←</p> <p>Show the full command list.</p>
<p><b>help N1</b> ←</p> <p>Show details about the specified command.</p> <p><b>N1</b> = {Command}</p>
<p><b>? </b> ←</p> <p>Show the full command list.</p>
<p><b>? N1</b> ←</p> <p>Show details about the specified command.</p> <p><b>N1</b> = {Command}</p>
<p><b>get fw ver</b> ←</p> <p>Show the unit's current firmware version.</p>
<p><b>set factory default</b> ←</p> <p>Reset the unit to the factory defaults.</p>
<p><b>set system usb fw update</b> ←</p> <p>Trigger the unit's firmware update state and load the new firmware file via USB.</p>

**COMMAND****Description and Parameters****set audio in N1 mute N2**

Set the volume mute state for the specified audio input.

Available values for **N1**:

1	[Analogue input 1]
2	[Analogue input 2]
3	[Analogue input 3]
4	[Analogue input 4]

Available values for **N2**:

ON	[Mute]
OFF	[Unmute]

**get audio in N1 mute**

Show the current mute state of the specified output.

Available values for **N1**:

1	[Analogue input 1]
2	[Analogue input 2]
3	[Analogue input 3]
4	[Analogue input 4]

**set audio in N1 pre-gain N2**

Set the pre-gain volume level for the specified audio input type.

Available values for **N1**:

1	[Analogue input 1]
2	[Analogue input 2]
3	[Analogue input 3]
4	[Analogue input 4]

**N2** = 0-100 [Volume level]

COMMAND	
Description and Parameters	
<b>get audio in N1 pre-gain</b> ↵	
Show the current pre-gain volume level for the specified audio input.	
Available values for <b>N1</b> :	
1	[Analogue input 1]
2	[Analogue input 2]
3	[Analogue input 3]
4	[Analogue input 4]
<b>set audio in N1 power mode N2</b> ↵	
Set the phantom power voltage level for use by microphones connected to the specified audio input.	
Available values for <b>N1</b> :	
1	[Analogue input 1]
2	[Analogue input 2]
3	[Analogue input 3]
4	[Analogue input 4]
Available values for <b>N2</b> :	
0	[No phantom power]
1	[5V]
2	[48V]
<b>get audio in N1 power mode</b> ↵	
Show the current phantom power voltage level on the specified audio input.	
Available values for <b>N1</b> :	
1	[Analogue input 1]
2	[Analogue input 2]
3	[Analogue input 3]
4	[Analogue input 4]

*Note: Commands will not be executed unless followed by a carriage return. Commands are not case-sensitive.*

## 7. CONNECTION DIAGRAM

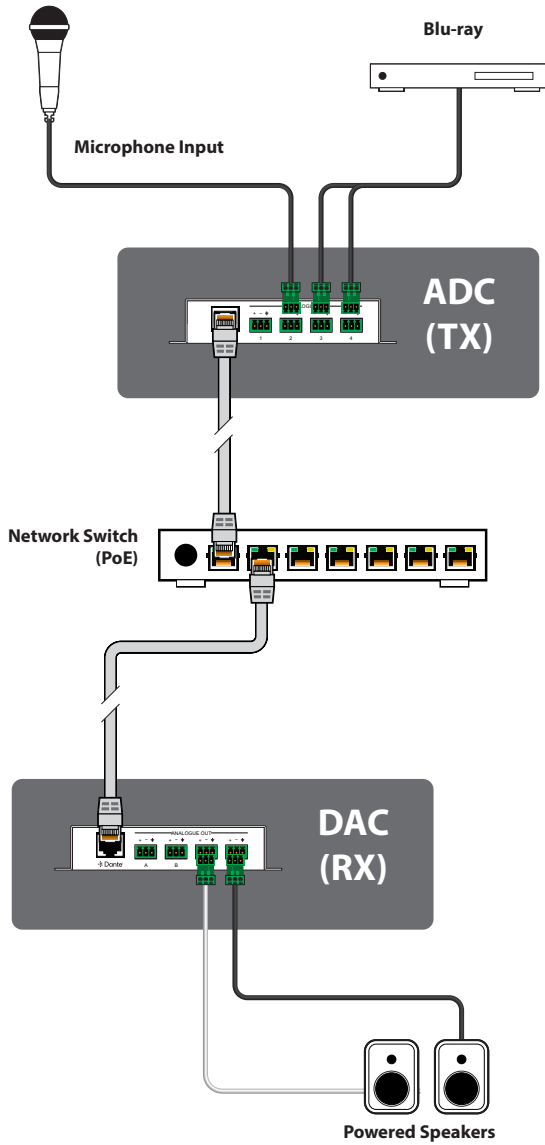

## 8. SPECIFICATIONS

### 8.1 Technical Specifications

<b>Ethernet Bandwidth</b>	100Mbps
<b>Input Ports</b>	4×Analogue Mono (3-pin Terminal Block)
<b>Output Port</b>	1×Dante (RJ-45)
<b>Service/Control Port</b>	1×USB 2.0 (Micro-B)
<b>Baud Rate</b>	19200
<b>Power Supply</b>	PoE (802.3af)
<b>ESD Protection (HBM)</b>	±8kV (Air Discharge) ±4kV (Contact Discharge)
<b>Dimensions (W×H×D)</b>	128mm×25mm×108mm [Case Only] 128mm×25mm×110mm [All Inclusive]
<b>Weight</b>	351g
<b>Chassis Material</b>	Metal (Aluminum)
<b>Chassis Colour</b>	Black
<b>Operating Temperature</b>	0°C – 40°C/32°F – 104°F
<b>Storage Temperature</b>	-20°C – 60°C/-4°F – 140°F
<b>Relative Humidity</b>	20 – 90% RH (Non-condensing)
<b>Power Consumption</b>	3.3W

## 8.2 Audio Specifications

### 8.2.1 Digital Audio

Dante Output	
LPCM	
Max Channels	4 Channels
Sampling Rate (kHz)	44.1, 48, 88.2, 96
Bitstream	
Supported Formats	None

### 8.2.2 Analog Audio

Analogue Input	
Max Audio Level	4Vrms
Impedance	42.3kΩ
Type	Balanced

## 8.3 Cable Specifications

Dante Audio Cable Length (Per network segment)	
Ethernet Cable	
Cat.5e/6	100m
Cat.6A/7	100m

## 9. ACRONYMS

ACRONYM	COMPLETE TERM
<b>ADC</b>	Analogue-to-Digital Converter
<b>Cat.5e</b>	Enhanced Category 5 cable
<b>Cat.6</b>	Category 6 cable
<b>Cat.6A</b>	Augmented Category 6 cable
<b>Cat.7</b>	Category 7 cable
<b>DAC</b>	Digital-to-Analogue Converter
<b>dB</b>	Decibel
<b>GbE</b>	Gigabit Ethernet
<b>Gbps</b>	Gigabits per second
<b>IP</b>	Internet Protocol
<b>kHz</b>	Kilohertz
<b>LAN</b>	Local Area Network
<b>LED</b>	Light-Emitting Diode
<b>LPCM</b>	Linear Pulse-Code Modulation
<b>MAC</b>	Media Access Control
<b>MHz</b>	Megahertz
<b>PD</b>	Powered Device
<b>PoE</b>	Power over Ethernet
<b>PSE</b>	Power Sourcing Equipment
<b>SNR</b>	Signal-to-Noise Ratio
<b>THD+N</b>	Total Harmonic Distortion plus Noise
<b>USB</b>	Universal Serial Bus
<b>Ω</b>	Ohm









---

CYP (UK) Ltd., Unit 7, Shepperton Business Park, Govett Avenue,  
Shepperton, Middlesex, TW17 8BA

Tel: +44 (0) 20 3137 9180 | Fax: +44 (0) 20 3137 6279

Email: [sales@cypeurope.com](mailto:sales@cypeurope.com)

[www.cypeurope.com](http://www.cypeurope.com)

v1.00