



## EL-21 PIP

2 Way HDMI Switch with Integrated Multiview  
(Picture In Picture) Technology

**OPERATION MANUAL**

**HDMI®**  
HIGH-DEFINITION MULTIMEDIA INTERFACE

The terms HDMI, HDMI High-Definition Multimedia Interface, and the HDMI Logo are trademarks or registered trademarks of HDMI licensing Administrator, Inc.

## **DISCLAIMERS**

The information in this manual has been carefully checked and is believed to be accurate. CYP (UK) Ltd assumes no responsibility for any infringements of patents or other rights of third parties which may result from its use.

CYP (UK) Ltd assumes no responsibility for any inaccuracies that may be contained in this document. CYP (UK) Ltd also makes no commitment to update or to keep current the information contained in this document.

CYP (UK) Ltd reserves the right to make improvements to this document and/or product at any time and without notice.

## **COPYRIGHT NOTICE**

No part of this document may be reproduced, transmitted, transcribed, stored in a retrieval system, or any of its part translated into any language or computer file, in any form or by any means—electronic, mechanical, magnetic, optical, chemical, manual, or otherwise—without express written permission and consent from CYP (UK) Ltd.

© Copyright 2020 by CYP (UK) Ltd.

All Rights Reserved.

Version 1.1

## **TRADEMARK ACKNOWLEDGMENTS**

All products or service names mentioned in this document may be trademarks of the companies with which they are associated.

## SAFETY PRECAUTIONS

Please read all instructions before attempting to unpack, install or operate this equipment and before connecting the power supply.

Please keep the following in mind as you unpack and install this equipment:

- Always follow basic safety precautions to reduce the risk of fire, electrical shock and injury to persons.
- To prevent fire or shock hazard, do not expose the unit to rain, moisture or install this product near water.
- Never spill liquid of any kind on or into this product.
- Never push an object of any kind into this product through any openings or empty slots in the unit, as you may damage parts inside the unit.
- Do not attach the power supply cabling to building surfaces.
- Use only the supplied power supply unit (PSU). Do not use the PSU if it is damaged.
- Do not allow anything to rest on the power cabling or allow any weight to be placed upon it or any person walk on it.
- To protect the unit from overheating, do not block any vents or openings in the unit housing that provide ventilation and allow for sufficient space for air to circulate around the unit.

## REVISION HISTORY

VERSION NO.	DATE	SUMMARY OF CHANGE
v1.00	21/06/2018	First release
V1.01	10/08/2020	Updated RS-232 Comands (HDCCP)

# CONTENTS

<b>1. Introduction .....</b>	<b>6</b>
<b>2. Applications .....</b>	<b>6</b>
<b>3. Package Contents .....</b>	<b>6</b>
<b>4. System Requirements .....</b>	<b>7</b>
<b>5. Features .....</b>	<b>7</b>
<b>6. Operation Controls and Functions .....</b>	<b>8</b>
6.1 Front Panel .....	8
6.2 Rear Panel.....	9
6.3 WebGUI Control .....	10
6.4 RS-232 Control.....	20
6.5 Telnet Control.....	20
<b>7. Connection Diagram .....</b>	<b>37</b>
<b>8. Specifications.....</b>	<b>38</b>
8.1 Technical Specifications .....	38
8.2 Video Specifications.....	39
8.3 Audio Specifications.....	40
8.4 Cable Specifications .....	41
<b>9. Acronyms.....</b>	<b>42</b>

## 1. INTRODUCTION

This HDMI Multiviewer is capable of scaling up to 2 sources and displaying both simultaneously on a single HDMI output within their own windows. This is the ideal solution for monitoring multiple sources simultaneously for use in control rooms, or for flexible display presentations in conference rooms or classrooms. Both inputs support resolutions up to 1920×1200@60Hz and LPCM audio with up to 7.1 channels at 192kHz.

The multi-window output is sent to a single HDMI output at scaled resolutions up to 1920×1200@60Hz along with the selected audio source. The HDMI output supports up to LPCM 7.1 digital audio while the analogue audio output supports up to LPCM 2.0. Each of the 2 HDMI sources may be displayed individually, full screen, or they can be displayed using a variety of dual-window modes including Picture-in-Picture, Side-by-Side, or freely positioned (with layer priority control). Each window can also be mirrored, flipped, swapped, or frozen (with live audio). Chromakeying and a custom uploadable logo/graphic are also supported.

By using an optional Windows PC application, the user can use their PC to generate images or text to be overlaid on top of a live HDMI input in real time. This unit can be controlled easily by use of the front panel controls (with OSD) as well as by WebGUI, Telnet, RS-232, IR, and 8 direct trigger inputs.

## 2. APPLICATIONS

- /// Demo Room Displays
- /// Security Monitoring
- /// Hotel Lobby Information Displays

## 3. PACKAGE CONTENTS

- /// 1×HDMI Multiviewer
- /// 1×5V/2.6A DC Power Adapter
- /// 3×5-pin Terminal Block
- /// 1×Shockproof Feet (Set of 4)
- /// 1×Operation Manual

## 4. SYSTEM REQUIREMENTS

- /// HDMI source equipment such as media players, video game consoles or set-top boxes.
- /// HDMI receiving equipment such as an HDTV, monitor, or audio amplifier.
- /// Analogue audio receiving equipment such as headphones, an audio amplifier or powered speakers.

## 5. FEATURES

- /// HDMI & HDCP 1.3 compliant
- /// 2 HDMI inputs and 1 HDMI output
- /// Inputs and output support HD resolutions up to 1080p@60Hz and PC resolutions up to WUXGA (RB)
- /// Supports audio pass-through of LPCM 2.0/5.1/7.1 sources via HDMI
- /// Balanced analogue stereo audio extraction support via 5-pin terminal block (LPCM 2.0 only)
- /// Supports PiP (Picture-in-Picture), Side-by-Side, and free positioning window modes
- /// Easy individual window size, position and layer priority adjustment
- /// Supports per-window mirror, flip, and image freeze (w/ live audio) functionality
- /// Chromakey support
- /// Uploadable logo support
- /// Support for Windows PC character generation software to simplify the process of generating text or graphics to use with keying/overlay (Optional)
- /// 8 Trigger inputs for easy remote control of the unit with optional keypad
- /// Supports front panel buttons (with OSD), WebGUI, Telnet, RS-232, IR, and Trigger controls

## 6. OPERATION CONTROLS AND FUNCTIONS

### 6.1 Front Panel

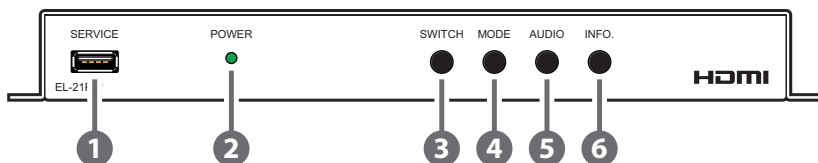

- 1 SERVICE:** This port is reserved for firmware update use only.
- 2 POWER LED:** This LED will illuminate to indicate the unit is on and receiving power.
- 3 SWITCH Button:** Press to toggle between the two HDMI inputs and output the selected source full screen.

*Note: Press and hold this button for 2 seconds to change the output resolution to 1920×1080p@60Hz.*

- 4 MODE Button:** Press to sequentially switch between the Full Screen (NONE), Picture-in-Picture (PIP), Side-by-Side (SBS), and Picture-outside-Picture (POP) windowing modes.

*Note: Press and hold this button for 2 seconds to change the output resolution to 1024×768@60Hz.*

- 5 AUDIO Button:** Press to toggle between the audio from the 2 HDMI inputs.
- 6 INFO. Button:** Short press to show the current input/output resolution status, audio selection and IP information. Long press to show the current contrast, brightness, hue, sharpness, colour format, chroma and colour temperature settings for each source channel.

## 6.2 Rear Panel

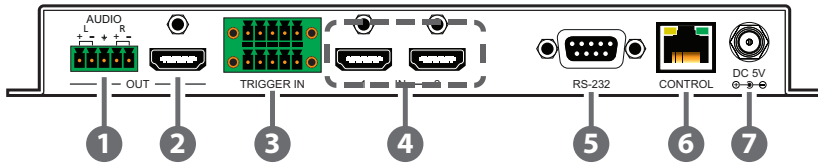

- 1 AUDIO OUT:** Connect to powered speakers or an amplifier for balanced stereo analogue audio output.
- 2 HDMI OUT:** Connect to an HDMI TV, monitor or amplifier for digital video and audio output.
- 3 TRIGGER IN:** This 10 pin terminal block provides 8 trigger pins (plus 5V & Ground) for activating pre-designated functions within the unit. Compatible with the optional Trigger Keypad unit.

Pins are numbered from left to right:

TOP ROW		BOTTOM ROW	
<b>1</b>	Vcc (5V)	<b>6</b>	GROUND
<b>2</b>	POP Windowing Mode	<b>7</b>	Image Freeze (Toggle)
<b>3</b>	SBS Windowing Mode	<b>8</b>	Display Logo (Toggle)
<b>4</b>	PIP Windowing Mode	<b>9</b>	A/V Mute (Toggle)
<b>5</b>	Full Screen Window (Toggle)	<b>10</b>	Window Source Swap (Toggle)

- 4 HDMI IN 1~2:** Connect to HDMI source equipment such as media players, game consoles or set-top boxes.
- 5 RS-232:** Connect directly to a PC, laptop or other serial control device to send RS-232 commands to control the unit.
- 6 CONTROL:** Connect directly, or through a network switch, to your PC/ laptop to control the unit via Telnet/WebGUI.
- 7 DC 5V:** Plug the 5V DC power adapter into the unit and connect it to an AC wall outlet for power.

## 6.3 WebGUI Control

### Device Discovery APP

Please obtain the “Device Discovery” software from your authorised dealer and save it in a directory where you can easily find it.

Connect the unit and your PC/Laptop to the same active network and execute the “Device Discovery” software. Click on “Find Devices on Network” and a list of devices connected to the local network will show up indicating their current IP address.

*Note: The unit’s default IP address is 192.168.1.50.*

Find Devices on Network			
Product Name	Description	IP Address	MAC Address

By clicking on one of the listed devices you will be presented with the network details of that particular device.

Product ID	
Product Name	
MAC Address	00:00:00:00:00:00
IP Address	<input type="text"/>
Subnet Mask	<input type="text"/>
Gateway IP	<input type="text"/>
DNS	<input type="text"/>
IP Mode	Static
Web GUI Port	Static
Telnet Port	DHCP
S / N	0
Firmware Version	
Hardware Version	
Description	
Web GUI	<a href="#">Web GUI</a>
<input type="button" value="Save"/> <input type="button" value="Reboot"/>	

- 1) IP Mode:** If you choose, you can alter the static IP network settings for the device, or switch the unit into DHCP mode to automatically obtain proper network settings from a local DHCP server. To switch to DHCP mode, please select DHCP from the IP mode drop-down, then click “Save” followed by “Reboot”.
- 2) WebGUI Hotkey:** Once you are satisfied with the network settings, you may use them to connect via Telnet or WebGUI. The network information window provides a convenient link to launch the WebGUI directly.

## WebGUI Overview

After connecting to the WebGUI's address in a web browser, the login screen will appear. Please enter the appropriate user name and password then click "Submit" to log in.

*Note: The default user name and password is "admin".*

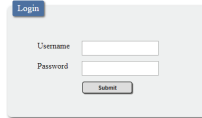
A screenshot of a web browser login form. At the top left is a blue tab labeled "Login". Below it are two input fields: "Username" and "Password". At the bottom center is a "Submit" button.

On the left side of the browser you will see the following menu tabs where all primary functions of the unit are controllable via the built in WebGUI: Adjustment, Windows Setup, OSD/LOGO Settings, Chromakey Setup, Network, and System. The individual functions will be introduced in the following sections.

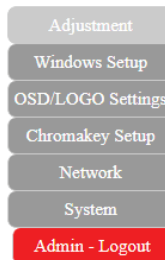

Clicking the red "Logout" tab will automatically log the currently connected user out of the WebGUI and return to login page.

## Information Bar

Across the top of the WebGUI are 5 sections that will always be displayed no matter which tab has been selected. These sections are: Information-In, Information-Out, Source, Mode, and Preset/Factory. They provide information about the state of the unit, or control the most basic functions of the unit.

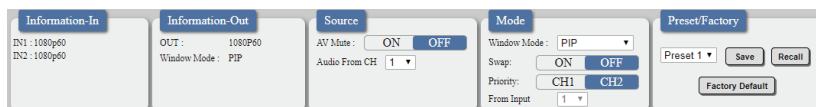

- 1) **Information-In:** Provides the detected resolution information about the source connected to each of the HDMI inputs.
- 2) **Information-Out:** Provides the unit's current output resolution as well as listing the current Window Mode.
- 3) **Source:** Provides controls for the A/V Mute function and Audio Source selection.

- **A/V Mute:** When A/V Mute is enabled, all output will be disabled on the HDMI output.
- **Audio From CH:** Select which HDMI input's audio to pass to both the HDMI and analogue outputs.

*Note: The analogue output can only support LPCM 2.0 audio. Bitstream audio will be automatically muted.*

- 4) **Mode:** Provides controls for changing the Window Mode, swapping window sources, changing window priority and selecting the input in the "NONE" window mode.

- **Window Mode:** Allows selecting the current windowing mode from 4 choices: PIP (Picture-in-Picture), SBS (Side-by-Side), POP (Picture-outside-Picture) and NONE (Full screen seamless switcher).

*Notes: The PIP, SBS, and POP modes will each recall their most recently saved window sizes and positions, not their default arrangements.*

*Changing this setting when Chromakey is enabled will automatically disable Chromakey mode.*

- **Swap:** Allows swapping the input channel between the windows in the multi-windowing modes.

*Note: Enabling Swap mode will also automatically switch the Priority setting in order to maintain the existing Window display priority.*

- **Priority:** Selects which input channel is on top in the multi-windowing modes.
- **From Input:** Selects the input to display when the unit is in the "NONE" (Full screen seamless switcher) Windowing Mode.

- 5) **Preset/Factory:** Provides controls for saving and loading Presets and

for resetting the unit.

- **Preset Save/Recall:** This unit can store and recall up to four presets. Each preset stores the settings from the Mode, Contrast, Brightness, Sharpness, Hue, image Still, Flip, and Upside-Down sections of the WebGUI for rapid, hassle-free, recall.

*Note: The output will briefly go black during the preset recall process.*

- **Factory Reset:** Click on the Factory Reset button to reset the unit to its factory default state. After the reset is complete, the unit will reboot automatically.

*Note: Network configuration details will not be reset.*

## Adjustment Tab

This tab provides controls over the general display characteristics of each input channel as well as providing a way to set the unit's output resolution.

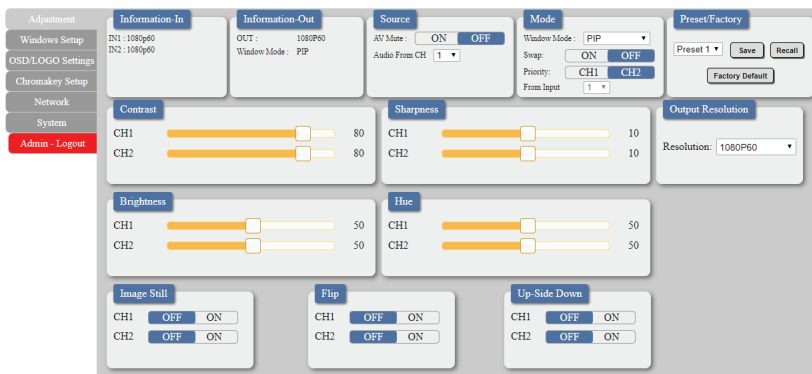

- 1) **Contrast:** Sets the contrast level for each input channel with a range of 0 to 100. Clicking on the slider will allow fine adjustments using the arrow keys. The default value is 80.
- 2) **Brightness:** Sets the brightness level for each input channel with a range of 0 to 100. Clicking on the slider will allow fine adjustments using the arrow keys. The default value is 50.
- 3) **Sharpness:** Sets the amount of sharpness processing to apply to each input channel with a range of 0 to 20. Clicking on the slider will allow fine adjustments using the arrow keys. The default value is 10.
- 4) **Hue:** Sets the hue value for each input channel with a range of 0 to

100. Clicking on the slider will allow fine adjustments using the arrow keys. The default value is 50.

- 5) **Output Resolution:** Sets the unit's output resolution. The default selection is 1080p60.
- 6) **Image Still:** Freezes and unfreezes the video from the selected input channel. This function is off by default.
- 7) **Flip:** Enabling the Flip function will cause the video in the selected input channel to be mirrored horizontally. This function is off by default.
- 8) **Up-Side Down:** Enabling the Upside-Down function will cause the video in the selected input channel to be mirrored vertically. This function is off by default.

### Windows Setup Tab

This tab provides access to controls for the individual windows in the multi-windowing modes (PIP, SBS, POP) of the unit including size and position. Both windows may be freely scaled and positioned in all 3 modes. Clicking on the bottom right corner of a window and dragging it will resize the window while clicking and dragging the center of a window will reposition it. Changes made to windows will occur immediately.

*Note: This tab will be completely disabled if Window Mode is set to "NONE".*

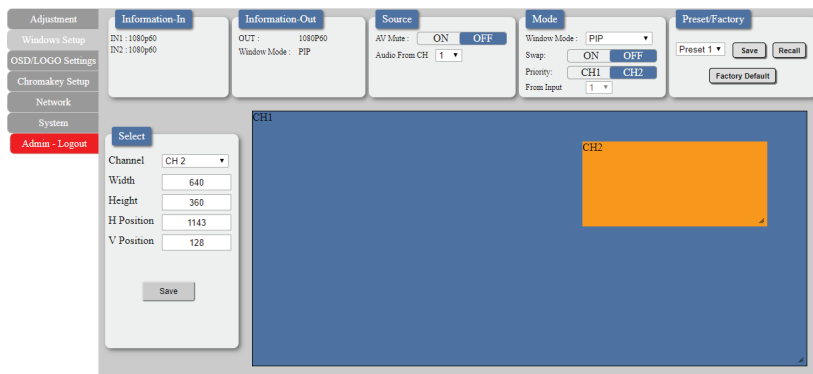

- 1) **Select:** This section provides a way to directly type exact position and size numbers for each channel window for precise alignment. After making all changes to a channel, please click the "Save" button to have the unit use the new values.

- **Channel:** Selects which channel to adjust.
- **Width:** Sets the horizontal size of the selected channel window in pixels.
- **Height:** Sets the vertical size of the selected channel window in pixels.
- **H Position:** Sets the horizontal position of the selected channel window in pixels.
- **V Position:** Sets the vertical position of the selected channel window in pixels.

*Note: Changing channels before clicking "Save" will undo any modified values.*

### OSD/LOGO Settings

This tab provides control over the informational OSD (On Screen Display) formatting as well as user uploaded logo usage and placement.

*Note: The OSD and Logo cannot be displayed simultaneously. Enabling the Logo function will automatically disable the OSD.*

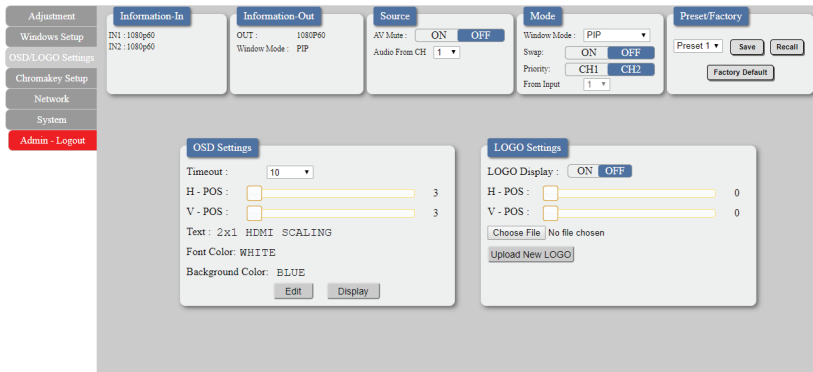

**1) OSD Settings:** This section provides control over all OSD formatting.

- **Timeout:** Sets the length of time for the OSD to remain on the screen in seconds.
- **H-Pos:** Sets the horizontal position of the OSD, set in percentage.
- **V-Pos:** Sets the vertical position of the OSD, set in percentage.
- **Text/Font Colour/Background Colour:** Displays the current values for the OSD format that are configured by clicking on the "Edit" button.

- **Edit:** Clicking this button opens the OSD Information Edit window to change the formatting of the OSD.

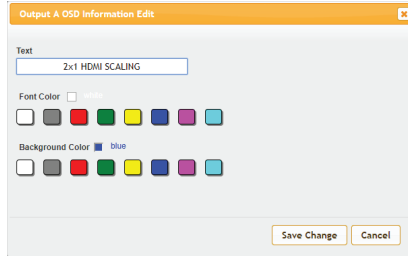

**Text:** Define a text string to display on the OSD.

**Font Colour:** Set the colour of the OSD font.

**Background Colour:** Set the background colour of the OSD's text block.

- 2) **LOGO Settings:** This section provides control over the content and position of the user uploaded logo image.
  - **Logo Display:** Clicking this button will display the customised text message on the OSD.
  - **H-Pos:** Sets the horizontal position of the user logo, set in percentage.
  - **V-Pos:** Sets the vertical position of the user logo, set in percentage.
  - **Upload New LOGO:** To upload a graphic logo, please click the "Choose File" button to open the file selection window and then select the graphic logo file (8-bit \*.bmp format, 1920×1080 max resolution) located on your local PC. After selecting the file, click the "Upload New LOGO" button to upload the logo to the unit.

## Chromakey Setup Tab

This tab allows for the activation and configuration of Chromakey mode. Enabling the Chromakey mode will automatically switch to displaying Input 1 underneath Input 2 with the selected key values applied to Input 2's source video. The unit comes with 8 pre-defined standard key definitions (White, Yellow, Cyan, Green, Magenta, Red, Blue, Black) and a User configurable definition set.

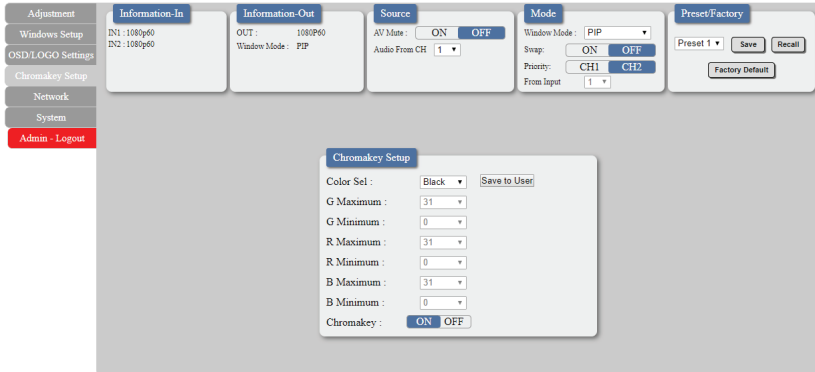

1) **Chromakey Setup:** This section provides all controls relating to the chromakeying function of the unit.

- **Colour Set:** Select from a list of pre-set chromakey ranges (White, Yellow, Cyan, Green, Magenta, Red, Blue, Black) to perform simple, hassle-free keying or select “User” to enter in custom keying value ranges. Clicking “Save to User” will copy the currently selected pre-set ranges into the “User” slot for editing.
- **G Maximum/Minimum:** When “User” is selected, sets the maximum and minimum range for the green component of the chromakey (from 0-255).
- **R Maximum/Minimum:** When “User” is selected, sets the maximum and minimum range for the red component of the chromakey (from 0-255).
- **B Maximum/Minimum:** When “User” is selected, sets the maximum and minimum range for the blue component of the chromakey (from 0-255).
- **Chromakey:** Enable or disable the chromakey function of the unit. When chromakeying is enabled, the unit will automatically switch

both windows to be full screen with Channel Window 1 in front of Channel Window 2. The keying will be applied to Channel Window 1.

*Note: Selecting any other Windowing mode will automatically disable chromakeying.*

## Network Tab

This tab provides access to control of the IP configuration and Login settings for the unit.

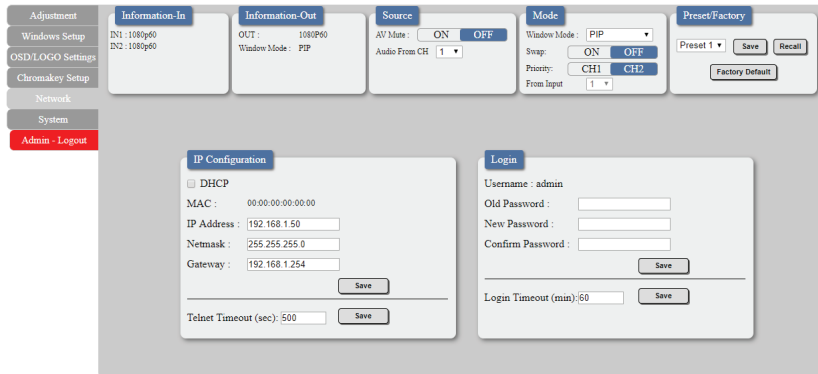

- 1) **IP Configuration:** The IP Address, Netmask and Gateway can be set manually, or DHCP can be enabled for automatic IP Configuration if your local network supports it. The Telnet Timeout can also be set, allowing control of the length of inactivity time before the unit releases its network connection with a network connected control device. Click on “Save” to confirm and activate any changes made to these settings.

*Note: If the IP address is changed then the IP address required for WebGUI or Telnet access will also change accordingly.*

- 2) **Login:** This section provides User Configuration options including changing the password for the Administrator account, and setting an idle user logout timer. Click on “Save” to confirm and activate any changes made to these settings.

## System Tab

This tab provides firmware update functionality and, system configuration backup/restore functions.

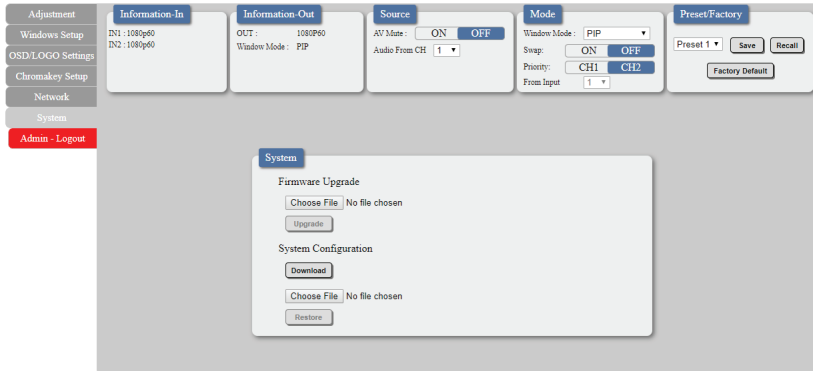

- 1) **System:** This section contains all controls relating to firmware upgrades and system configuration export.
  - **Firmware Upgrade:** To update the unit's firmware, click the "Choose File" button to open the file selection window and then select the firmware update file (\*.bin format) located on your local PC. After selecting the file, click the "Upgrade" button to begin the firmware update process. Once the process completes the unit will automatically reboot.
  - **System Configuration:** The current system configuration, including routing and presets, may be saved as an XML file to a PC. Click the "Download" button to save the current system configuration to your local PC. Previously saved system configurations may be restored from a saved XML file. Click the "Choose File" button to locate the saved XML file, then click the "Restore" button. Once the process completes the unit will automatically reboot.

## 6.4 RS-232 Control

UNIT		TERMINAL	
Pin	Pinout	Pin	Pinout
1		1	
2	TxD	2	RxD
3	RxD	3	TxD
4		4	
5	GND	5	GND
6		6	
7		7	
8		8	
9		9	

SERIAL PORT SETTINGS	
<b>Baud Rate</b>	19200
<b>Data Bits</b>	8
<b>Parity Bit</b>	None
<b>Stop Bits</b>	1
<b>Flow Control</b>	None

## 6.5 Telnet Control

Before attempting to use Telnet control, please ensure that both the unit and the PC are connected to the same active networks.

To Access the Command Line Interface (CLI)	
Windows 7	Click <b>Start</b> , type “cmd” in the search field, and press <b>Enter</b> .
Windows XP	Click <b>Start &gt; Run</b> , type “cmd”, and press <b>Enter</b> .
Mac OS X	Click <b>Go &gt; Applications &gt; Utilities &gt; Terminal</b> .

Once in the Command Line Interface (CLI) type “**telnet**” followed by the IP address of the unit (and the port number if it is non-standard) and then hit “Enter”. This will connect us to the unit we wish to control. Type “**help**” to list the available commands. See below for reference.

```
Microsoft Windows [Version 6.1.7601]
Copyright (c) 2009 Microsoft Corporation. All rights reserved.

C:\Users\Administrator>telnet 192.168.1.50 23
```

*Note: If the IP address is changed then the IP address required for Telnet access will also change accordingly.*

## 6.6 RS-232 and Telnet Commands

COMMAND
DESCRIPTION & PARAMETERS
<b>?↵</b>
Show the full command list.
<b>HELP↵</b>
Show the full command list.
<b>GET FW VER↵</b>
Show the unit's current firmware version.
<b>SET FACTORY DEFAULT↵</b>
Reset all configurations to the factory defaults.
<b>SAVE PRESET N1↵</b>
Save the current configuration as preset <b>N1</b> . <b>N1</b> = 1 ~ 4 [Preset number]
<b>RECALL PRESET N1↵</b>
Recall the saved configuration from preset <b>N1</b> . <b>N1</b> = 1 ~ 4 [Preset number]
<b>SET OUT A ROUTE N1↵</b>
Switch to full screen routing mode and show input <b>N1</b> . <b>N1</b> = 1 ~ 2 [Input port]
<b>GET OUT A ROUTE↵</b>
Show the currently set full screen routing source.
<b>SET WINDOW LAYOUT MODE N1↵</b>
Set the windowing mode to <b>N1</b> . Available values for <b>N1</b> :
1 [PIP mode]
2 [SBS mode]
4 [POP mode]
5 [Full screen routing mode]

COMMAND
DESCRIPTION & PARAMETERS
<b>GET WINDOW LAYOUT MODE</b> ←
Show the currently selected windowing mode.
<b>SET OUT A WINDOW PRIORITY N1</b> ←
Select which input window will have top display priority in the dual-windowing modes. <b>N1</b> = 1 ~ 2                      [Input port]
<b>GET OUT A WINDOW PRIORITY</b> ←
Show which input window currently has top display priority.
<b>SET WINDOW SWAP N1</b> ←
Enable or disable the input window swap function. Available values for <b>N1</b> : 0                                      [Off] 1                                      [On]
<b>GET WINDOW SWAP</b> ←
Show the current state of the window swap function.
<b>SET IN AUTO MODE N1</b> ←
Enable or disable the auto input switching mode. Available values for <b>N1</b> : 0                                      [Off] 1                                      [On]
<b>GET IN AUTO MODE</b> ←
Show the current state of the auto input mode.

COMMAND									
DESCRIPTION & PARAMETERS									
<b>SET IN N1 HDCP N2↵</b>									
<p>Enable or disable HDCP at the HDMI inputs</p> <p>Available Values for <b>N1</b>:</p> <table> <tr> <td>1</td> <td>Set for HDMI input 1</td> </tr> <tr> <td>2</td> <td>Set for HDMI input 2</td> </tr> </table> <p>Available Values for <b>N2</b>:</p> <table> <tr> <td>0</td> <td>Set HDCP to off</td> </tr> <tr> <td>1</td> <td>Set HDCP to On</td> </tr> </table>		1	Set for HDMI input 1	2	Set for HDMI input 2	0	Set HDCP to off	1	Set HDCP to On
1	Set for HDMI input 1								
2	Set for HDMI input 2								
0	Set HDCP to off								
1	Set HDCP to On								
<b>SET IN N1 EDID N2↵</b>									
<p>Set the EDID to use with input <b>N1</b>.</p> <p><b>N1</b> = 1 ~ 2                      [Input port]</p> <p>Available values for <b>N2</b>”</p> <table> <tr> <td>1</td> <td>[Internal EDID 1]</td> </tr> <tr> <td>2</td> <td>[Internal EDID 2]</td> </tr> <tr> <td>15</td> <td>[Sink]</td> </tr> </table>		1	[Internal EDID 1]	2	[Internal EDID 2]	15	[Sink]		
1	[Internal EDID 1]								
2	[Internal EDID 2]								
15	[Sink]								
<b>GET IN N1 EDID↵</b>									
<p>Show the EDID source currently used by input <b>N1</b>.</p> <p><b>N1</b> = 1 ~ 2                      [Input port]</p>									

COMMAND	
DESCRIPTION & PARAMETERS	
<b>SET OUT A TIMING N1</b> ←↵	
Set the scaled output resolution.	
Available values for <b>N1</b> :	
0	[Native]
4	[480P60]
6	[720P60]
10	[1080P60]
11	[576P50]
12	[720P50]
16	[1080P24]
17	[1080P25]
19	[1080P30]
416	[1024×768]
417	[1280×800]
419	[1280×1024]
420	[1366×768]
423	[1440×900]
424	[1600×900RB]
425	[1600×1200]
426	[1680×1050]
430	[1920×1200RB]
<b>GET OUT A TIMING</b> ←↵	
Show the currently selected output resolution.	
<b>GET OUT A TIMING STRING</b> ←↵	
Show the currently selected output resolution's timing description.	
<b>SET OUT A AUDIO SOURCE N</b> ←↵	
Select the HDMI audio source to send to the output.	
<b>N1</b> = 1 ~ 2	[Input port]

COMMAND
DESCRIPTION & PARAMETERS
<b>GET OUT A AUDIO SOURCE</b> ↵
Show the currently selected HDMI audio source.
<b>SET OUT A MUTE N1</b> ↵
Enable or disable the audio/video output mute function. Available values for <b>N1</b> :
0 [Off]
1 [On]
<b>GET OUT A MUTE</b> ↵
Show the current state of the audio/video output mute function.
<b>GET OUT A SYNC STATUS</b> ↵
Show the current sync state of the HDMI output.
<b>SET IN N1 CONTRAST N2</b> ↵
Set the contrast value for input <b>N1</b> .
<b>N1</b> = 1 ~ 2 [Input port]
<b>N2</b> = 0 ~ 100 [Contrast level]
<b>GET IN N1 CONTRAST</b> ↵
Show the current contrast value for input <b>N1</b> .
<b>N1</b> = 1 ~ 2 [Input port]
<b>SET IN N1 BRIGHTNESS N2</b> ↵
Set the brightness value for input <b>N1</b> .
<b>N1</b> = 1 ~ 2 [Input port]
<b>N2</b> = 0 ~ 100 [Brightness level]
<b>GET IN N1 BRIGHTNESS</b> ↵
Show the current brightness value for input N1.
<b>N1</b> = 1 ~ 2 [Input port]

COMMAND
DESCRIPTION & PARAMETERS
<p><b>SET IN N1 HUE N2</b> ←↵</p> <p>Set the hue shift for input <b>N1</b>.</p> <p><b>N1</b> = 1 ~ 2                      [Input port]  <b>N2</b> = 0 ~ 100                      [Hue]</p>
<p><b>GET IN N1 HUE</b> ←↵</p> <p>Show the current hue shift for input <b>N1</b>.</p> <p><b>N1</b> = 1 ~ 2                      [Input port]</p>
<p><b>SET IN N1 SHARPNESS N2</b> ←↵</p> <p>Set the sharpness value for input <b>N1</b>.</p> <p><b>N1</b> = 1 ~ 2                      [Input port]  <b>N2</b> = 0 ~ 20                      [Sharpness level]</p>
<p><b>GET IN N1 SHARPNESS</b> ←↵</p> <p>Show the current sharpness value for input <b>N1</b>.</p> <p><b>N1</b> = 1 ~ 2                      [Input port]</p>
<p><b>SET OUT A ASPECT RATIO N1</b> ←↵</p> <p>Set the output aspect ratio to use in full screen mode.</p> <p>Available values for <b>N1</b>:</p> <p>1                                      [Full]  2                                      [4:3]  3                                      [16:9]  4                                      [16:10]</p>

COMMAND
DESCRIPTION & PARAMETERS
<p><b>GET OUT A ASPECT RATIO</b> ←←</p> <p>Show the current aspect ratio setting.</p>
<p><b>SET IN N1 FORMAT N2</b> ←←</p> <p>Force input <b>N1</b> to use a specific colour format.</p> <p><b>N1</b> = 1 ~ 2                      [Input port]</p> <p>Available values for <b>N2</b>:</p> <p>1                                      [RGB]</p> <p>2                                      [YPbPr 4:2:2]</p> <p>3                                      [YPbPr 4:4:4]</p>
<p><b>GET IN N1 FORMAT</b> ←←</p> <p>Show the currently set colour space format used by input <b>N1</b>.</p> <p><b>N1</b> = 1 ~ 2                      [Input port]</p>
<p><b>SET IN N1 TEMPERATURE N2</b> ←←</p> <p>Set the colour temperature to use with input <b>N1</b>.</p> <p><b>N1</b> = 1 ~ 2                      [Input port]</p> <p>Available values for <b>N2</b>:</p> <p>1                                      [6500K]</p> <p>2                                      [9300K]</p>
<p><b>GET IN N1 TEMPERATURE</b> ←←</p> <p>Show the currently set colour temperature used by input <b>N1</b>.</p>
<p><b>SET IN N1 CHROMA N2</b> ←←</p> <p>Set the chroma value for input <b>N1</b>.</p> <p><b>N1</b> = 1 ~ 2                      [Input port]</p> <p><b>N2</b> = 0 ~ 100                    [Chroma value]</p>

COMMAND	
DESCRIPTION & PARAMETERS	
<b>GET IN N1 CHROMA</b> ←	
<p>Show the current chroma value for input <b>N1</b>.</p> <p><b>N1</b> = 1 ~ 2                      [Input port]</p>	
<b>SET CHROMAKEY ENABLE N1</b> ←	
<p>Enable or disable Chromakey mode.</p> <p>Available values for <b>N1</b>:</p> <p>0                                      [Off]</p> <p>1                                      [On]</p>	
<b>GET CHROMAKEY ENABLE</b> ←	
<p>Show the current state of the Chromakey mode.</p>	
<b>SET CHROMAKEY Colour N1</b> ←	
<p>Select the RGB chromakey preset to use when Chromakey mode is enabled.</p> <p>Available values for <b>N1</b>:</p> <p>WHITE                              [White key]</p> <p>BLACK                                [Black key]</p> <p>RED                                    [Red key]</p> <p>GREEN                                [Green key]</p> <p>YELLOW                              [Yellow key]</p> <p>BLUE                                 [Blue key]</p> <p>MAGENTA                            [Magenta key]</p> <p>CYAN                                 [Cyan key]</p> <p>USER                                 [User defined key]</p>	
<b>GET CHROMAKEY Colour</b> ←	
<p>Show the currently selected RGB chroma preset.</p>	

COMMAND	
DESCRIPTION & PARAMETERS	
<b>SET CHROMAKEY RED RANGE N1 TO N2</b> ↵	
Set the key-out range to use for the red component of the User defined key.	
<b>N1</b> = 00 ~ FF	[Red min in hex]
<b>N2</b> = 00 ~ FF	[Red max in hex]
<b>SET CHROMAKEY GREEN RANGE N1 TO N2</b> ↵	
Set the key-out range to use for the green component of the User defined key.	
<b>N1</b> = 00 ~ FF	[Green min in hex]
<b>N2</b> = 00 ~ FF	[Green max in hex]
<b>SET CHROMAKEY BLUE RANGE N1 TO N2</b> ↵	
Set the key-out range to use for the blue component of the User defined key.	
<b>N1</b> = 00 ~ FF	[Blue min in hex]
<b>N2</b> = 00 ~ FF	[Blue max in hex]
<b>GET CHROMAKEY N1 RANGE</b> ↵	
Show the current key range set for the selected colour component.	
Available values for <b>N1</b> :	
RED	[Red component]
GREEN	[Green component]
BLUE	[Blue component]

COMMAND
DESCRIPTION & PARAMETERS
<p><b>SET IN N1 HPOSITION N2</b> ←←</p> <p>Set the horizontal position of the upper-left corner of input <b>N1</b>'s window in pixels. The maximum position value is the current horizontal resolution minus 1.</p> <p><b>N1</b> = 1 ~ 2                      [Input port]  <b>N2</b> = 0 ~ {Resolution-1}      [Horizontal position]</p> <p><i>Note: Only available in dual-windowing modes.</i></p>
<p><b>GET IN N1 HPOSITION</b> ←←</p> <p>Show the current horizontal position of the upper-left corner of input <b>N1</b>'s window in pixels.</p> <p><b>N1</b> = 1 ~ 2                      [Input port]</p>
<p><b>SET IN N1 VPOSITION N2</b> ←←</p> <p>Set the vertical position of the upper-left corner of input <b>N1</b>'s window in pixels. The maximum position value is the current vertical resolution minus 1.</p> <p><b>N1</b> = 1 ~ 2                      [Input port]  <b>N2</b> = 0 ~ {Resolution-1}      [Vertical position]</p> <p><i>Note: Only available in dual-windowing modes.</i></p>
<p><b>GET IN N1 VPOSITION</b> ←←</p> <p>Show the current vertical position of the upper-left corner of input <b>N1</b>'s window in pixels.</p> <p><b>N1</b> = 1 ~ 2                      [Input port]</p>
<p><b>SET IN N1 WIDTH N2</b> ←←</p> <p>Set the horizontal size of input <b>N1</b>'s window in pixels. The maximum value is the current horizontal resolution.</p> <p><b>N1</b> = 1 ~ 2                      [Input port]  <b>N2</b> = 0 ~ {Resolution}        [Horizontal size]</p> <p><i>Note: Only available in dual-windowing modes.</i></p>

COMMAND	
DESCRIPTION & PARAMETERS	
<b>GET IN N1 WIDTH</b> ↵	
<p>Show the current horizontal size of input <b>N1</b>'s window in pixels.</p> <p><b>N1</b> = 1 ~ 2                      [Input port]</p>	
<b>SET IN N1 HEIGHT N2</b> ↵	
<p>Set the vertical size of input <b>N1</b>'s window in pixels. The maximum value is the current vertical resolution.</p> <p><b>N1</b> = 1 ~ 2                      [Input port]</p> <p><b>N2</b> = 0 ~ {Resolution}        [Vertical size]</p> <p><i>Note: Only available in dual-windowing modes.</i></p>	
<b>GET IN N1 HEIGHT</b> ↵	
<p>Show the current vertical size of input <b>N1</b>'s window in pixels.</p> <p><b>N1</b> = 1 ~ 2                      [Input port]</p>	
<b>SET IN N1 UP-SIDE DOWN N2</b> ↵	
<p>Enable or disable the vertical flip function for input <b>N1</b>.</p> <p><b>N1</b> = 1 ~ 2                      [Input port]</p> <p>Available values for <b>N2</b>:</p> <p>ON                                    [Enable]</p> <p>OFF                                   [Disable]</p>	
<b>GET IN N1 UP-SIDE DOWN</b> ↵	
<p>Show the current vertical flip state for input <b>N1</b>.</p> <p><b>N1</b> = 1 ~ 2                      [Input port]</p>	
<b>SET IN N1 FLIP N2</b> ↵	
<p>Enable or disable the horizontal flip function for input <b>N1</b>.</p> <p><b>N1</b> = 1 ~ 2                      [Input port]</p> <p>Available values for <b>N2</b>:</p> <p>ON                                    [Enable]</p> <p>OFF                                   [Disable]</p>	

COMMAND	
DESCRIPTION & PARAMETERS	
<b>GET IN N1 FLIP</b> ←	
Show the current horizontal flip state for input <b>N1</b> .	
<b>N1</b> = 1 ~ 2	[Input port]
<b>SET IN N1 IMAGE STILL N2</b> ←	
Enable or disable the video freeze function for input <b>N1</b> .	
<b>N1</b> = 1 ~ 2	[Input port]
Available values for <b>N2</b> :	
ON	[Enable]
OFF	[Disable]
<b>GET IN N1 IMAGE STILL</b> ←	
Show the current video freeze state for input <b>N1</b> .	
<b>N1</b> = 1 ~ 2	[Input port]
<b>SET IN N1 BACKDROP Colour N2</b> ←	
Set the free run colour for input <b>N1</b> .	
<b>N1</b> = 1 ~ 2	[Input port]
Available values for <b>N2</b> :	
BLACK	[Black colour]
BLUE	[Blue colour]
<b>GET IN N1 BACKDROP Colour</b> ←	
Show the currently set free run colour for input <b>N1</b> .	
<b>N1</b> = 1 ~ 2	[Input port]
<b>SET OUT A OSD INFO TIMEOUT N1</b> ←	
Set the OSD display timeout length, or disable the timeout.	
<b>N1</b> = 0 ~ 100	[Timeout in seconds]
<b>GET OUT A OSD INFO TIMEOUT</b> ←	
Show the current OSD timeout length.	

COMMAND	
DESCRIPTION & PARAMETERS	
<b>SET OUT A OSD INFO VPOSITION N1</b> ←	
Set the vertical position of the OSD.	
<b>N1</b> = 0 ~ 100	[Vertical position in %]
<b>GET OUT A OSD INFO VPOSITION</b> ←	
Show the OSD's current vertical position.	
<b>SET OUT A OSD INFO HPOSITION N1</b> ←	
Set the horizontal position of the OSD.	
<b>N1</b> = 0 ~ 100	[Horizontal position in %]
<b>GET OUT A OSD INFO HPOSITION</b> ←	
Show the OSD's current horizontal position.	
<b>SET OUT A OSD TEXT N1</b> ←	
Set the custom OSD text string.	
<b>N1</b> = {Text string}	[Custom text]
<b>GET OUT A OSD TEXT</b> ←	
Show the current custom OSD text string.	
<b>SET OUT A OSD FONT Colour N1</b> ←	
Set the colour of the OSD text.	
Available values for <b>N1</b> :	
WHITE	[White text]
GRAY	[Gray text]
RED	[Red text]
GREEN	[Green text]
YELLOW	[Yellow text]
BLUE	[Blue text]
MAGENTA	[Magenta text]
CYAN	[Cyan text]
<b>GET OUT A OSD FONT Colour</b> ←	
Show the current OSD text colour.	

COMMAND	
DESCRIPTION & PARAMETERS	
<b>SET OUT A OSD BACKDROP Colour N1</b> ←←	
Set the colour of the OSD background. Available values for <b>N1</b> :	
WHITE	[White text]
GRAY	[Gray text]
RED	[Red text]
GREEN	[Green text]
YELLOW	[Yellow text]
BLUE	[Blue text]
MAGENTA	[Magenta text]
CYAN	[Cyan text]
<b>GET OUT A OSD BACKDROP Colour</b> ←←	
Show the current OSD background colour.	
<b>SET OUT A OSD LOGO DISPLAY N1</b> ←←	
Enable or disable the OSD graphical logo. Available values for <b>N1</b> :	
ON	[Enabled]
OFF	[Disabled]
<b>GET OUT A OSD LOGO DISPLAY</b> ←←	
Show the current state of the OSD graphical logo.	
<b>SET OUT A OSD LOGO VPOSITION N1</b> ←←	
Set the vertical position of the OSD graphical logo. <b>N1</b> = 0 ~ 100 [Vertical position in %]	
<b>GET OUT A OSD LOGO VPOSITION</b> ←←	
Show the current vertical position of the OSD graphical logo.	
<b>SET OUT A OSD LOGO HPOSITION N1</b> ←←	
Set the horizontal position of the OSD graphical logo. <b>N1</b> = 0 ~ 100 [Horizontal position in %]	

COMMAND	
DESCRIPTION & PARAMETERS	
<b>GET OUT A OSD LOGO HPOSITION</b> ↵	
	Show the current horizontal position of the OSD graphical logo.
<b>GET WEBGUI USERNAME</b> ↵	
	Show the current WebGUI username.
<b>SET WEBGUI PASSWORD N1</b> ↵	
	Set the WebGUI login password to <b>N1</b> .
<b>N1</b> = {password}	[15 characters max]
<b>GET WEBGUI PASSWORD</b> ↵	
	Show the current WebGUI password.
<b>SET WEBGUI TIMEOUT N1</b> ↵	
	Set the WebGUI inactivity timeout.
<b>N1</b> = 0 ~ 6000	[Timeout in minutes]
<b>GET WEBGUI TIMEOUT</b> ↵	
	Show the current WebGUI inactivity timeout value.
<b>SET IP MODE N1</b> ↵	
	Set the IP address assignment mode.
	Available values for <b>N1</b> :
0	[Static IP mode]
1	[DHCP mode]
<b>GET IP MODE</b> ↵	
	Show the current IP mode.
<b>GET IPCONFIG</b> ↵	
	Show the current IP configuration data.
<b>SET IP ADDR N1</b> ↵	
	Set the static IP address.
<b>N1</b> = X.X.X.X	[X = 0 ~ 255]

COMMAND	
DESCRIPTION & PARAMETERS	
<b>SET NETMASK N1</b> ↵	
Set the static netmask address. <b>N1</b> = X.X.X.X                      [X = 0 ~ 255]	
<b>SET GATEWAY N1</b> ↵	
Set the static gateway address. <b>N1</b> = X.X.X.X                      [X = 0 ~ 255]	
<b>SET TELNET TIMEOUT N1</b> ↵	
Set the Telnet inactivity timeout. <b>N1</b> = 0 ~ 6000                      [Timeout in seconds]	
<b>GET TELNET TIMEOUT</b> ↵	
Show the current Telnet inactivity timeout value.	
<b>SET TELNET PORT N1</b> ↵	
Set the network port to use for Telnet communication. <b>N1</b> = 1 ~ 65535                      [Telnet port]	
<b>GET TELNET PORT</b> ↵	
Show the current Telnet port.	

*Note: Commands will not be executed unless followed by a carriage return. Commands are not case-sensitive.*

## 7. CONNECTION DIAGRAM

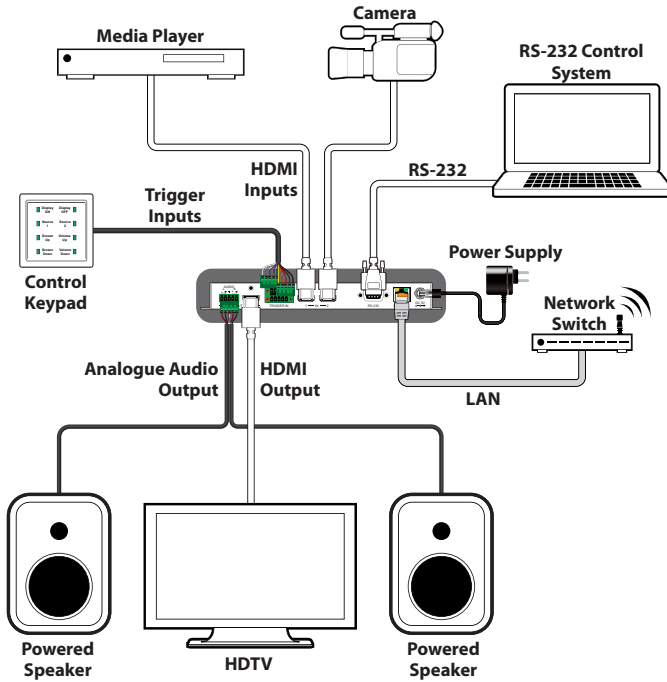

### Screen Configurations:

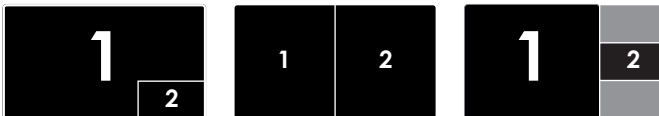

## 8. SPECIFICATIONS

### 8.1 Technical Specifications

<b>HDMI Bandwidth</b>	225MHz/6.75Gbps
<b>Input Ports</b>	2×HDMI
<b>Output Ports</b>	1×HDMI 1×Stereo (Terminal Block)
<b>Control Interfaces</b>	8×Trigger (Terminal Block) 1×RS-232 (9-pin D-sub) 1×IP Control (RJ-45)
<b>Baud Rate</b>	Up to 115200bps
<b>Power Supply</b>	5V/2.6A DC (US/EU standards, CE/FCC/UL certified)
<b>ESD Protection</b>	Human Body Model: ±8kV (Air Discharge) ±4kV (Contact Discharge)
<b>Dimensions</b>	231.5mm×25mm×108mm (W×H×D) [Case Only] 231.5mm×25mm×116mm (W×H×D) [All Inclusive]
<b>Weight</b>	652g
<b>Chassis Material</b>	Metal
<b>Silkscreen Colour</b>	Black
<b>Operating Temperature</b>	0 °C–40 °C/32 °F–104 °F
<b>Storage Temperature</b>	-20 °C–60 °C/-4 °F–140 °F
<b>Relative Humidity</b>	20–90% RH (Non-condensing)
<b>Power Consumption</b>	5.1W

## 8.2 Video Specifications

Supported PC Resolution (Hz)	HDMI Input	HDMI Output
<b>640×480@60</b>	✓	x
<b>640×480@72</b>	✓	x
<b>640×480@75</b>	✓	x
<b>640×480@85</b>	✓	x
<b>800×600@56</b>	✓	x
<b>800×600@60</b>	✓	x
<b>800×600@72</b>	✓	x
<b>800×600@75</b>	✓	x
<b>800×600@85</b>	✓	x
<b>1024×768@60</b>	✓	✓
<b>1024×768@70</b>	✓	x
<b>1024×768@75</b>	✓	x
<b>1024×768@85</b>	✓	x
<b>1280×800@60</b>	✓	✓
<b>1280×960@60</b>	✓	x
<b>1280×1024@60</b>	✓	✓
<b>1360×768@60</b>	✓	x
<b>1366×768@60</b>	✓	✓
<b>1440×900@60</b>	✓	✓
<b>1600×900@60</b>	✓	x
<b>1600×900@60 (RB)</b>	x	✓
<b>1600×1200@60</b>	✓	✓
<b>1680×1050@60</b>	✓	✓
<b>1920×1200@60 (RB)</b>	✓	x

Supported TV Resolution (Hz)	HDMI Input	HDMI Output
<b>720x480i@60</b>	✓	x
<b>720x480p@60</b>	✓	✓
<b>720x576i@50</b>	✓	x
<b>720x576p@50</b>	✓	✓
<b>1280x720p@50</b>	✓	✓
<b>1280x720p@60</b>	✓	✓
<b>1920x1080i@50</b>	✓	x
<b>1920x1080i@60</b>	✓	x
<b>1920x1080p@24</b>	✓	✓
<b>1920x1080p@25</b>	✓	✓
<b>1920x1080p@30</b>	✓	✓
<b>1920x1080p@50</b>	✓	✓
<b>1920x1080p@60</b>	✓	✓

### 8.3 Audio Specifications

Analogue Output	
<b>Max Audio Level</b>	2Vrms
<b>THD+N</b>	< -86dB@0dBFS 1kHz (A-wt)
<b>SNR</b>	> 110dB@0dBFS
<b>Frequency Response</b>	< ±3dB@20Hz~20kHz
<b>Crosstalk</b>	< -100dB@10kHz
<b>Impedance</b>	47Ω
<b>Type</b>	Balanced/Unbalanced

## 8.4 Cable Specifications

HDMI Cable Length	1080p	
	8-bit	12-bit
<b>Input</b>	10m	10m
<b>Output</b>	10m	10m

## 9. ACRONYMS

<b>ACRONYM</b>	<b>COMPLETE TERM</b>
<b>CLI</b>	Command-Line Interface
<b>EDID</b>	Extended Display Identification Data
<b>GUI</b>	Graphical User Interface
<b>HD</b>	High-Definition
<b>HDCP</b>	High-bandwidth Digital Content Protection
<b>HDMI</b>	High-Definition Multimedia Interface
<b>HDTV</b>	High-Definition Television
<b>IP</b>	Internet Protocol
<b>LPCM</b>	Linear Pulse-Code Modulation
<b>PC</b>	Personal Computer
<b>PiP</b>	Picture-in-Picture
<b>PoP</b>	Picture-outside-Picture
<b>SbS</b>	Side-by-Side
<b>SNR</b>	Signal-to-Noise Ratio
<b>THD+N</b>	Total Harmonic Distortion plus Noise
<b>WUXGA (RB)</b>	Widescreen Ultra Extended Graphics Array (Reduced Blanking)





---

CYP (UK) Ltd., Unit 7, Shepperton Business Park, Govett Avenue,  
Shepperton, Middlesex, TW17 8BA

Tel: +44 (0) 20 3137 9180 | Fax: +44 (0) 20 3137 6279

Email: [sales@cypeurope.com](mailto:sales@cypeurope.com)

[www.cypeurope.com](http://www.cypeurope.com)

v1.01