



# IP-9000RX

1G 4K60 AV over IP Receiver with USB & PoE

**OPERATION MANUAL**

 Dante®

 Audinate®

Dante Ready™

**HDMI**®  
HIGH-DEFINITION MULTIMEDIA INTERFACE

The terms HDMI, HDMI High-Definition Multimedia Interface, and the HDMI Logo are trademarks or registered trademarks of HDMI Licensing Administrator, Inc.

## **DISCLAIMERS**

The information in this manual has been carefully checked and is believed to be accurate. CYP (UK) Ltd assumes no responsibility for any infringements of patents or other rights of third parties which may result from its use.

CYP (UK) Ltd assumes no responsibility for any inaccuracies that may be contained in this document. CYP (UK) Ltd also makes no commitment to update or to keep current the information contained in this document.

CYP (UK) Ltd reserves the right to make improvements to this document and/or product at any time and without notice.

## **COPYRIGHT NOTICE**

No part of this document may be reproduced, transmitted, transcribed, stored in a retrieval system, or any of its part translated into any language or computer file, in any form or by any means—electronic, mechanical, magnetic, optical, chemical, manual, or otherwise—without express written permission and consent from CYP (UK) Ltd.

© Copyright 2024 by CYP (UK) Ltd.

All Rights Reserved.

Version 1.1

## **TRADEMARK ACKNOWLEDGMENTS**

All products or service names mentioned in this document may be trademarks of the companies with which they are associated.

---



## SAFETY PRECAUTIONS

Please read all instructions before attempting to unpack, install or operate this equipment and before connecting the power supply. Please keep the following in mind as you unpack and install this equipment:

- Always follow basic safety precautions to reduce the risk of fire, electrical shock and injury to persons.
- To prevent fire or shock hazard, do not expose the unit to rain, moisture or install this product near water.
- Never spill liquid of any kind on or into this product.
- Never push an object of any kind into this product through any openings or empty slots in the unit, as you may damage parts inside the unit.
- Do not attach the power supply cabling to building surfaces.
- Use only the supplied power supply unit (PSU). Do not use the PSU if it is damaged.
- Do not allow anything to rest on the power cabling or allow any weight to be placed upon it or any person walk on it.
- To protect the unit from overheating, do not block any vents or openings in the unit housing that provide ventilation and allow for sufficient space for air to circulate around the unit.
- Please completely disconnect the power when the unit is not in use to avoid wasting electricity.

## VERSION HISTORY

REV.	DATE	SUMMARY OF CHANGE
<b>v1.00</b>	16/09/2024	Initial Release
<b>v1.01</b>	12/11/2024	Added note about PSU
<b>v1.02</b>	25/11/2024	Updated some descriptions
<b>v1.03</b>	14/04/2025	Updated Features (Latency)

# CONTENTS

<b>1. Introduction</b> .....	<b>1</b>
<b>2. Applications</b> .....	<b>2</b>
<b>3. Package Contents</b> .....	<b>2</b>
<b>4. System Requirements</b> .....	<b>3</b>
<b>5. Features</b> .....	<b>4</b>
<b>6. Operation Controls and Functions</b> .....	<b>5</b>
6.1 Front Panel .....	5
6.2 Rear Panel.....	6
6.3 IR Cable Pinouts .....	7
6.4 Serial Defaults.....	7
6.5 WebGUI Control .....	8
6.5.1 System Tab .....	10
6.5.2 Video Wall Tab .....	13
6.5.3 Network Tab.....	17
6.5.4 Functions Tab .....	19
6.6 Telnet Control.....	23
6.7 Telnet Commands .....	23
6.8 Hotkey Control .....	38
<b>7. Dante Ready</b> .....	<b>40</b>
7.1 Dante Ready Compatibility.....	40
7.1.1 Quick Walkthrough .....	40
7.1.2 Online Activation.....	41
<b>8. Connection Diagram</b> .....	<b>45</b>
<b>9. Specifications</b> .....	<b>46</b>
9.1 Technical Specifications .....	46
9.2 Video Specifications.....	47
9.3 Audio Specifications.....	49
9.3.1 Digital Audio .....	49
9.3.2 Analogue Audio .....	49
9.3.3 AVoIP Audio Availability.....	50
9.4 Cable Specifications .....	51
<b>10. Acronyms</b> .....	<b>52</b>

---

## 1. INTRODUCTION

The IP-9000RX 1G AV over IP decoder with full 4K HDR and Dolby Vision support is the latest advancement in AV over IP technology. Supporting both Unicast and Multicast modes, enabling AV signals distribution with video wall modes and USB functionality in Multicast mode. It supports the transmission of Ultra High-Definition signals (up to 4K@60Hz 4:4:4 plus 4K HDR and Dolby Vision) with audio, IR, RS-232 and USB 2.0 up to 100m on a single cable. The USB connectivity allows for the connection of USB flash drives, webcams, keyboard, and mouse etc. The transmission distance can be further extended (up to 100m per segment) by using gigabit network switches, allowing the user to cascade the system without signal loss or introducing delay.

When the extension system's units are in multicast mode, a single transmitter's AV signal can be sent to a large number of receivers within the same local network without the additional receivers causing any bandwidth requirement increase. Additionally, that same multicast signal can be used to create large multi-display video walls with amazing simplicity. When combined with the optional IP Master Controller (IP-CS9000) the functionality of the system expands exponentially. Its centralised web-based interface greatly simplifies control and management of large, distributed video matrix or video wall systems adding to their flexibility in large residential or commercial installations.

This system also features bi-directional IR and RS-232 pass-through, analogue line level in/out, and a microphone input (on the receiver), providing the user with a variety of audio options. The USB functionality allows the system to act like a remote USB hub which, when combined with the HDMI input/output feature, provides a flexible remote platform for the seamless control of multiple PC systems. Configuration information is provided via On Screen Display (OSD) and the decoder own WebGUI plus using the IP-CS9000 IP Master Controller, and direct Telnet commands.

The IP-9000RX is Dante Ready which can transmit Dante data upon activation and is compatible with any standard Dante audio transmitters/receivers that the audio might be routed to. Dante Ready provides a flexible way to enable and expand the connectivity and interoperability of the world's de-facto AV-over-IP solution, even after the initial purchase. Upgrade your system with Dante and connect to over 4,000 products from 500 manufacturers. Dante Ready is built within the widely used

Dante Controller application for Dante audio and video subscription management. Transactions are simple and secure, and device upgrades are seamlessly actioned without the need to enter complex license keys of copy license files.

## 2. APPLICATIONS

- /// HDMI, USB, Audio, IR, and RS-232 extension
- /// Broadcasting a system over a single Cat.5e/6/7 cable
- /// Multimedia display on a large number of displays via multicast
- /// Hotel or convention center display multi-monitor broadcast
- /// Long distance data and video transmission via cascading
- /// Distributed video matrix system
- /// Distributed video wall system
- /// Seamless control of PC systems

## 3. PACKAGE CONTENTS

- /// 1× IP-9000RX AV over IP Receiver
- /// 1× IR Extender cable
- /// 1× Operation Manual
- /// 1× 3-way phoenix block

*Note: This device is generally PoE powered and as such its PSU, the PSU-12V1.25A-L is not supplied. Contact your CYP distributor to order the optional PSU*

## 4. SYSTEM REQUIREMENTS

- /// HDMI receiving equipment such as an HDTV, monitor, or audio amplifier.
- /// Audio receiving equipment such as headphones, an audio amplifier or powered speakers.
- /// A Gigabit Ethernet network switch with jumbo frame support is required for multi-unit configurations. (8K jumbo frames are strongly recommended.)
- /// A Gigabit Ethernet switch with “IGMP snooping” enabled is required for multicast support.
- /// The use of Premium High Speed HDMI cables, and industry standard Cat.6, Cat.6A, or Cat.7 Ethernet cable is highly recommended.
- /// An active network connection from a switch or router that supports PoE (802.3af) for extension of Dante audio and to power the unit.
- /// 3rd party control software, such as Dante Controller from Audinate, is required to configure and manage audio routes between Dante endpoints.

## 5. FEATURES

- /// 4K@60 1Gbps AV over IP Receiver in Unicast or Multicast mode
  - /// Full 4K60 4:4:4, HDR10, HDR10+, Dolby Vision & HLG compatible
  - /// Less than one frame of latency at 4K 60Hz.
  - /// IP interface: RJ45
  - /// Supports USB over IP (flash drive, USB web cam (isochronous/Bulk), keyboard and mouse) and seamless control of multiple PC systems
  - /// Supports PoE-PD (IEEE 802.3af)
  - /// Bi-directional IR and RS-232 pass-through
  - /// Controlled via hotkey, WebGUI, IP Master Controller, and Telnet
  - /// Supports the use of an external control system (IP Master Controller) to provide expanded functionality (Contact your authorised dealer for more information)
  - /// 7 hotkeys dedicated to routing for transmitters and receivers, 4 hotkeys provide single unctions, and 3 hotkeys for multiple functions that activates control system.
  - /// Supports independent breakaway A/V and control matrix routing
  - /// Supports extension of many audio formats including 8 channel LPCM and standard Bitstream
- Note: The Line Out only supports LPCM 2.0 sources.*
- /// The analogue Line In is automatically embedded in the streaming output and can be independently routed to any receiver
  - /// The Mic In sends audio directly to the analogue Line Out on the currently routed transmitter
- Note: Only available when the transmitter also has its Line In connected. Supported in unicast mode only.*
- /// Optional Dante Ready™ is compatible with existing Dante and AES67 audio networks
  - /// Dante Ready brings Dante functionality to products already shipping and installed in sites.
  - /// Channels and features can be added as an installation grows.

## 6. OPERATION CONTROLS AND FUNCTIONS

### 6.1 Front Panel

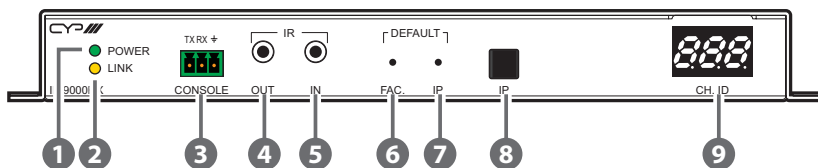

- 1 POWER LED:** This LED will flash while the unit is powering on and will illuminate solidly once it is ready to be used.
- 2 LINK LED:** If the receiver has no network connection the LINK LED will not illuminate. While the receiver is attempting to establish a connection with a transmitter the LINK LED will flash. When the receiver has established a stable connection with a transmitter the LINK LED will illuminate solidly.

- 3 CONSOLE CTL 3-pin Terminal Block:** Connect to a PC, laptop, or serial controllable device with a 3-pin adapter cable for the extension of RS-232 signals to the currently routed receiver. The baud rate is configurable, but the default baud rate is 115200.

*Note: When the transmitter is in multicast mode every connected receiver unit can send RS-232 commands to the transmitter and commands sent from the transmitter side will be sent to all associated receivers.*

- 4 IR OUT Port:** Connect to the provided IR Blaster to transmit IR signals from the associated transmitter to devices within direct line-of-sight of the IR Blaster.
- 5 IR IN Port:** Connect to the provided IR Extender to extend the IR control range of remotely located devices. Ensure that the remote being used is within direct line-of-sight of the IR Extender.
- 6 RESET FAC. Pinhole:** Press this recessed button to reboot the unit and all settings will be returned to the factory defaults (Including resetting the IP mode to auto, broadcast channel to 0, and the streaming mode to multicast). A new IP address will be assigned automatically within the 169.254.xxx.xxx address range.
- 7 RESET IP Pinhole:** Press this recessed button to reset the unit's IP settings and reboot the unit.

- 8 **IP Button:** Press this button to sequentially display the current broadcast channel and IP address.
- 9 **CH. ID Display:** Display information of current broadcast channel and IP address.

## 6.2 Rear Panel

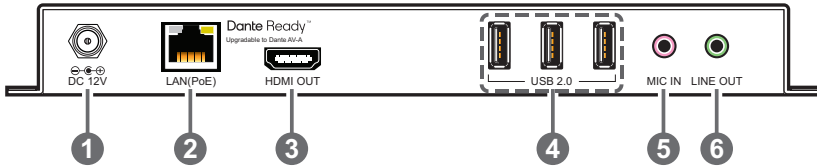

- 1 **DC 12V Port:** Plug the 12V DC power adapter into the unit and connect it to an AC wall outlet for power.  
*Note: Optional, not needed if the unit is powered via PoE.*
- 2 **LAN (PoE) Port:** Connect via a Gigabit Ethernet switch to compatible transmitters to receive video and data, or to a PC/laptop to control the unit via WebGUI.  
*Note: This unit can be powered directly by the connected Gigabit Ethernet switch if it provides PoE (802.3af).*
- 3 **HDMI OUT Port:** Connect to HDMI TVs, monitors or amplifiers for digital video and audio output.
- 4 **USB 2.0 (Type-A) Ports:** These 3 USB 2.0 slots provide connections for USB devices requiring higher transfer speeds such as thumb drives.
- 5 **MIC IN Port:** Connect to an analogue microphone using a 3.5mm plug. This audio will be sent to the analogue audio output on the currently routed transmitter. (Unicast mode ONLY)  
*Note: The Mic In audio channel back to the transmitter is only active when an analogue source is also connected to the Line In port on the transmitter.*
- 6 **LINE OUT Port:** Outputs stereo audio from the currently routed transmitter (LPCM 2.0 sources only). Connect to powered speakers or an amplifier for stereo analogue audio output.

### 6.3 IR Cable Pinouts

IR Blaster Cable

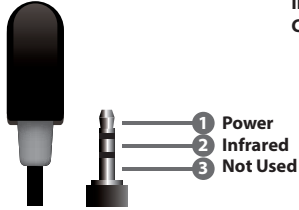

IR Extender Cable

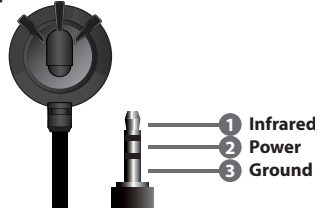

### 6.4 Serial Defaults

Serial Port Default Settings	
<b>Baud Rate</b>	115200
<b>Data Bits</b>	8
<b>Parity Bits</b>	None
<b>Stop Bits</b>	1
<b>Flow Control</b>	None

## 6.5 WebGUI Control

### Device Discovery

Please obtain the “Device Discovery” software from your authorised dealer and save it in a directory where you can easily find it.

Connect the unit and your PC/Laptop to the same active network and execute the “Device Discovery” software. Click on “Find Devices on Internet” and a list of devices connected to the local network will show up indicating their current IP address.

*Note: This unit defaults to Auto IP mode. The current IP address can be verified via the receiver’s OSD or front panel if the Device Discovery software is not available.*

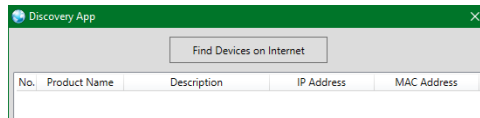

By clicking on one of the listed devices you will be presented with the network details of that particular device.

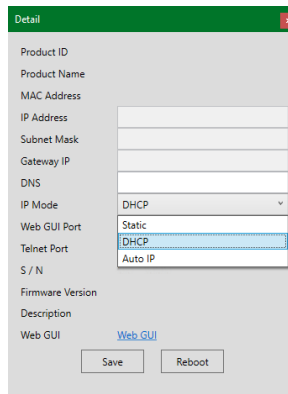

- 1) **IP Mode:** If you choose, you can alter the static IP network settings for the device, or switch the unit into DHCP mode to automatically obtain proper network settings from a local DHCP server. To switch to DHCP mode, please select DHCP from the IP mode drop-down, then click “Save” followed by “Reboot”.
- 2) **WebGUI Hotkey:** Once you are satisfied with the network settings, you may use them to connect via Telnet or WebGUI. The network

information window provides a convenient link to launch the WebGUI directly.

### WebGUI Overview

All major functions of the unit, including status, streaming method, streaming channel selection, output resolution, video wall configuration, EDID management, Ethernet settings, and reset/firmware functions are controllable via multiple tabs in the WebGUI interface allowing for reasonably intuitive operation.

Each transmitter, receiver, or transceiver is controlled by its own WebGUI interface which may be accessed by opening a standard web browser on a PC and typing in the IP address of the unit you wish to connect to.

On stand-alone transmitters/receivers you can discover the IP address by checking the status OSD that is displayed when there is no live video source or no live link, each connected receiver will output a 640×480 black screen with OSD text at the bottom identifying its own IP address (Local IP), as well as the IP address of the transmitter (Remote IP) that shares the same broadcasting channel with it (channel 0 by default).

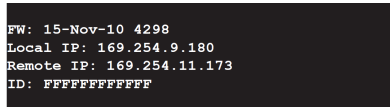

```
FW: 15-Nov-10 4298
Local IP: 169.254.9.180
Remote IP: 169.254.11.173
ID: FFFFFFFFFF
```

After connecting to a unit's WebGUI, you will find a screen containing multiple tabs for each functionality area of the unit. The individual tabs and functions will be introduced in the following sections.

*Note: AVoIP streaming uses a large amount of bandwidth (especially at higher resolutions) and a Gigabit Ethernet network switch with jumbo frame support and IGMP snooping is required. A professional managed switch with VLAN support is strongly recommended. Please note that most consumer-grade routers are not able to handle the high traffic rates generated by multicast mode, so using a router directly as your network switch is discouraged. It is strongly suggested to avoid mixing your regular network traffic with AVoIP streaming traffic and the AVoIP traffic should exist within a separate subnet, at the minimum.*

### 6.5.1 System Tab

The System tab contains 4 windows that provide access to firmware version information, a firmware update interface, utilities for rebooting and resetting the unit, Telnet command entry, and a variety of statistics and information about the operational state of the unit.

- 1) **Version Information:** This window displays detailed information about the current firmware version.

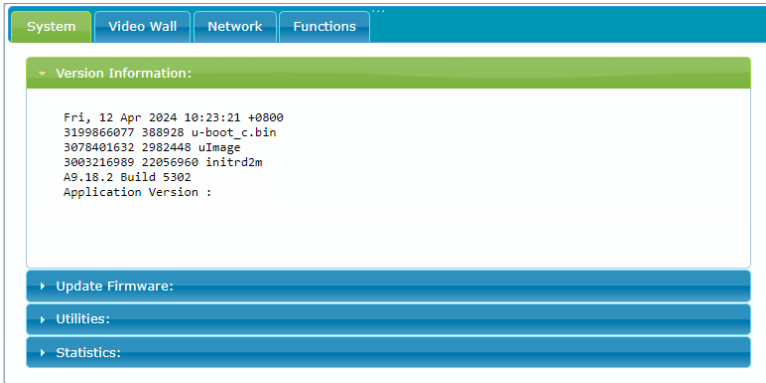

- 2) **Update Firmware:** Provides a way to update the unit's firmware. Click "Choose File" to select the firmware update file from the local PC (\*.bin format). After selecting an appropriate file, click the "Upload" button to begin the update process.

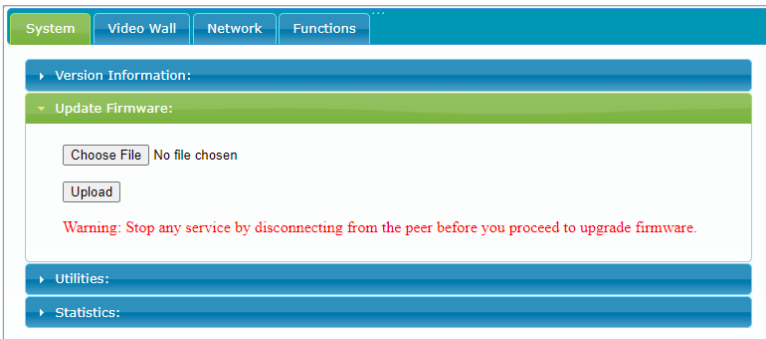

- 3) **Utilities:** The Utilities window allows users to reset the unit back to the factory defaults by clicking “Factory Default”. The unit may be rebooted (without resetting settings) by pressing the “Reboot” button.

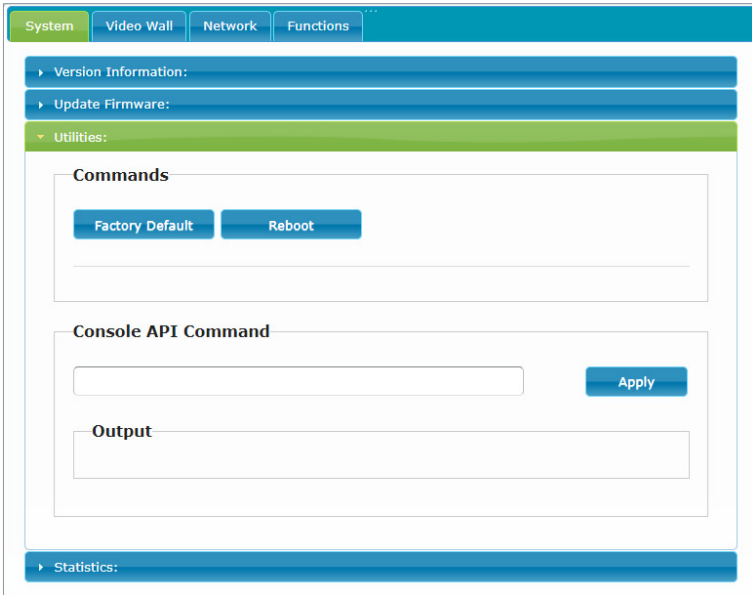

Finally, individual Telnet commands may be sent to the unit by using the “Console API Command” text entry field and pressing “Apply”. Any responses from the unit will be displayed in the “Output” field.

- 4) **Statistics:** The Statistics window shows all available information about the operational status of the unit, including current ID Channel, serial number, Ethernet information, MAC address, unicast/multicast mode, link status and mode, as well as the real-time details of the video source currently received on the unit.

The screenshot shows a web interface with the following content:

- System** | Video Wall | Network | Functions
- Version Information:
- Update Firmware:
- Utilities:
- Statistics:**
  - State Machine**

State: s\_srv\_on
  - Network**

ID (Channel): 52  
IP Address: 169.254.3.67  
Subnet Mask: 255.255.0.0  
Default Gateway: 169.254.0.254  
MAC Address:  
Casting Mode: Multicast Mode  
Link Status: on  
Link Mode: 1G  
S/N:
  - Video**

Local Video Output:  
Attached: n

Video Timing Information:

```

Output Timing convert: enabled [0x82000000]
Convert Timing Table[0x0000]: Serial Number[0x0000] [1920]x[1080] [60]Hz
Pixel Rate: 148500KHz, Htotal: 2200, Vtotal: 1125
Hbp: 148, Vbp: 36, Hsw: 44, Vsw: 5
Progressive, HPos, VPos
Src Timing Table[0x0000]: Serial Number[0x0000] [1920]x[1080] [60]Hz
Pixel Rate: 148500KHz, Htotal: 2200, Vtotal: 1125
Hbp: 148, Vbp: 36, Hsw: 44, Vsw: 5
Progressive, HPos, VPos
Src Signal Type: HDMI 16:9
Src Scan Mode: Progressive
Src Color Depth: [0]
Src Pixel Format: RGB
Src Colorimetry: RGB
Src Quantization: Full
HDR: off
TTL: SDR, 1ch
HDCP: [off]
HDCP Convert: Disable
Capture windows: [1920]x[1080] [60]Hz
Compress windows: [1920]x[1080] [60]Hz
Active windows: [1920]x[1080] [60]Hz
CRT windows: [1920]x[1080]

```

### 6.5.2 Video Wall Tab

The Video Wall tab allows user to design, edit and manipulate a video wall system created using multiple receiver units connected to identical displays. The bezel and video size of the displays being used, as well as the horizontal and vertical monitor count, is defined here. Video stretch and rotation can also be controlled on this tab.

System
Video Wall
Network
Functions

▼ Basic Setup:

#### Bezel and Gap Compensation

**OW:**

**OH:**

**VW:**

**VH:**

UNIT: 0.1mm

#### Wall Size and Position Layout

**Vertical Monitor Count:**

**Horizontal Monitor Count:**

**Row Position:**

**Column Position:**

UNIT: Panel

#### Preferences

**Stretch Type:**

**Rotate and Flip:**

**Apply To: "This" device connected by your browser**

To make changes to the unit you are currently connected to, select “This” as the target. Otherwise, select the IP address of the receiver (client) you want to apply changes to from the “Apply To:” drop down.

*Note: While it is possible to create small video walls using unicast mode, in order to more efficiently use the available network bandwidth, it is strongly recommended to only use multicast mode when creating video walls.*

- 1) Bezel and Gap Compensation:** This section of the Video Wall tab is used to define the physical dimensions of each display being used in the video wall. Accurate measurements are needed of the monitor’s outer frame (OW, OH) and the video screen (VW, VH). The measurements may be made using any unit format (inches, mm, cm, etc.) as long as ALL measurements in the same wall are made using the exact same units and the numbers are integers.

**Bezel and Gap Compensation**

OW:

OH:

VW:

VH:

UNIT: 0.1mm

- **OW (Outer Width):** This is the horizontal measurement of the display’s outer case.
- **OH (Outer Height):** This is the vertical measurement of the display’s outer case.
- **VW (Video Width):** This is the horizontal measurement of the display’s video screen.
- **VH (Video Height):** This is the vertical measurement of the display’s video screen.

*Note: Typically all monitors in a video wall are identical and have the same dimensions, but it is possible to use differently sized displays as long as the same measurement units are used to measure each display and the displays are still arranged in a normal rectangular layout with corners meeting at the same place.*

2) **Wall Size and Position Layout:** This section of the Video Wall tab is used to define the number of displays used in the video wall as well as the location of the specific display within the video wall. A typical video wall consists of an equal number of horizontal and vertical monitors (for example: 2×2 or 3×3), however it is possible to create video walls using this system with a wider variety of dimensions as long as the end result is still a rectangle (for example: 5×1 or 2×3). Both horizontal and vertical dimensions are limited to a maximum of 16 displays.

**Wall Size and Position Layout**

**Vertical Monitor Count:**

**Horizontal Monitor Count:**

**Row Position:**

**Column Position:**

UNIT: Panel

- **Vertical Monitor Count:** Define the number of displays in the video wall, measured vertically. (Maximum is 16 displays)
- **Horizontal Monitor Count:** Define the number of displays in the video wall, measured horizontally. (Maximum is 16 displays)
- **Row Position:** Set the vertical location of the currently controlled display. (Counts top to bottom, from 0 to 15)
- **Column Position:** Set the horizontal location of the currently controlled display. (Counts left to right, from 0 to 15)

- 3) **Preferences:** This section of the Video Wall tab provides additional controls over how the source video is displayed on the video wall as well as providing a drop down to determine which receiver to apply changed settings to.

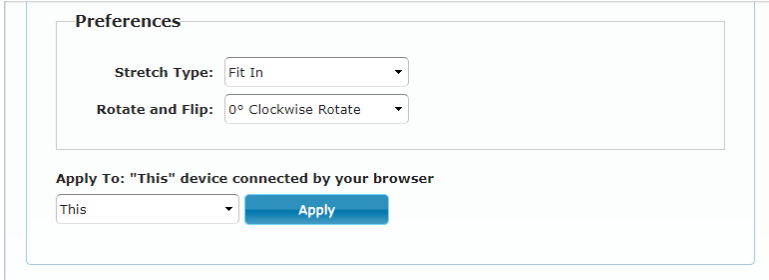

Preferences

Stretch Type: Fit In

Rotate and Flip: 0° Clockwise Rotate

Apply To: "This" device connected by your browser

This Apply

- **Stretch Type:** Set the video stretch method.
  - Selecting "Fit In" will expand the video to exactly fit the dimensions of the video wall regardless of the source's original aspect ratio.
  - Selecting "Stretch Out" will zoom the video until the video wall is filled in all 4 dimensions while maintaining the aspect ratio of the original source.
- **Rotate and Flip:** Set the video output to 0, 90, 180 or 270 degrees clockwise rotate, as well as putting it into horizontal or vertical flip.
- **Apply To:** Select which unit(s) to send updated settings to when "Apply" is pressed.
  - Selecting "This" will direct updates to the video wall settings of the unit who's WebGUI you are currently connected to.
  - Selecting an IP address from the "Clients" list will direct updates to the video wall settings of the receiver with that IP address.

### 6.5.3 Network Tab

The Network tab provides controls over the receiver's IP configuration, network broadcast mode, and broadcast reception channel. Changes made to the network settings will require a reboot of the unit. After clicking on "Apply" please follow the reboot instructions in the WebGUI.

*Note: If the IP address is changed then the IP address required for WebGUI access will also change accordingly. If the new address is assigned via "Auto IP" or "DHCP" it might temporarily disable the Video Link between the receiver and transmitter in order to display the units' new IP addresses on the receiver's HDMI output.*

The screenshot shows the Network configuration page in a web interface. At the top, there are four tabs: System, Video Wall, Network (highlighted in green), and Functions. Below the tabs, the page is divided into three main sections:

- IP Setup:** This section contains several controls:
  - IP Mode:** Three buttons: Auto IP (highlighted in green), DHCP, and Static.
  - IP Address:** A text input field containing "169.254.3.67".
  - Subnet Mask:** A text input field containing "255.255.0.0".
  - Default Gateway:** A text input field containing "169.254.0.254".
  - Find Your Device:** Two buttons: Hide Me (highlighted in green) and Show Me.
  - An **Apply** button is located at the bottom right of this section.
- Casting Mode:** This section contains two buttons: Multicast (highlighted in green) and Unicast. An **Apply** button is located at the bottom right of this section.
- ID (Channel):** This section contains a text input field with the value "0" and an **Apply** button to its right.

At the bottom center of the interface, there is a **Reboot** button.

1) **IP Setup:** This section allows for configuration of the IP acquisition mode and Ethernet settings of the unit. It also provides an easy way to find the physical unit when installed with many other similar units.

- **IP Mode & Settings:** The IP mode may be switched between “Auto IP”, “DHCP” or “Static IP”. When the unit is set to Auto IP mode it will automatically assign itself an APIPA address from the 169.254.xxx.xxx range. When the unit is set to DHCP mode it will attempt to automatically obtain an IP address from a DHCP server. When the IP mode is set to static IP, you can manually set the IP address, netmask and gateway address. Click the “Apply” button to save changes made to the IP Mode or Configuration.

*Note: The default network setting for this unit is “Auto IP”.*

- **Find Your Device:** Selecting “Show Me” will cause the unit to immediately begin flashing the LEDs on the front of the unit to make it easy to find. Selecting “Hide Me” returns the LEDs to their normal behavior. This setting is useful when troubleshooting an installation with a large number of units in a rack.

2) **Casting Mode:** Allows for the selection of the network broadcast mode supported by the receiver. Click the “Apply” button to save changes made to the broadcast mode.

*Note: Receivers must be set to the same mode as the transmitter in order to receive video.*

- **Multicast:** This mode sends a single video stream that can be viewed simultaneously by multiple receivers without increasing bandwidth usage. This mode is ideal for video wall or matrixing scenarios. Multicast mode requires a network switch with IGMP snooping enabled.
- **Unicast:** This mode uses a discrete video stream for every connected receiver and is ideal for simple, point-to-point, streaming setups. This mode uses considerably more bandwidth than Multicast Mode when multiple receivers are being used, however it does not require a network switch that supports IGMP snooping.

3) **ID (Channel):** To change the broadcast reception channel for the receiver, type the new channel in the space provided. The receiver will display the video stream from the transmitter using the selected broadcast channel. The available channel range is from 0 to 255.

### 6.5.4 Functions Tab

The Functions tab provides control over the receiver’s output resolution, video loss settings, as well as a wide variety of optional features and functions, including USB and serial control extension. Changes made to these settings typically require a reboot of the unit. After clicking on “Apply” please follow the reboot instructions in the WebGUI, if necessary.

- 1) **Video over IP:** This section allows control over functions of the receiver for controlling the behavior upon signal loss.

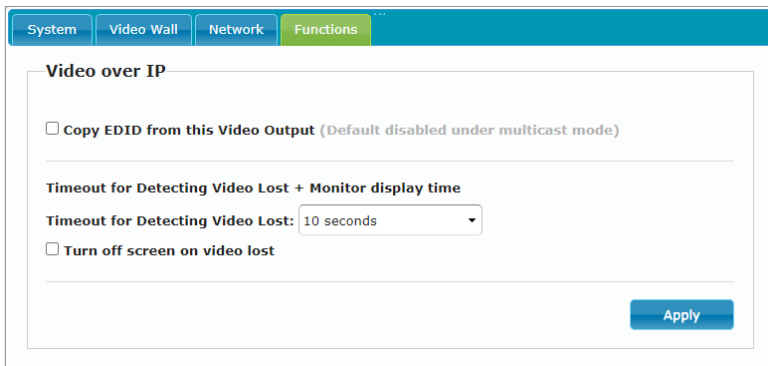

- **Copy EDID:** When multiple receivers are connected to a single transmitter in multicast mode, this check box selects which of the receivers should send its EDID to the transmitter for use with the source.

*Note: This option is only available in multicast mode. Only one receiver within the same streaming group should have this checked at a time to avoid conflicts.*

- **Video Loss Options:** Use the drop down to set the length of time to wait for a lost source to return before showing the Link Lost screen. Available options are: 3, 5, 10, 20, 30, 60 seconds, or Never Timeout. If the “Turn off screen” checkbox is checked, the HDMI output will be completely disabled, including sync, after the timeout time has passed.

- 2) **Display Setup:** This section allows control over functions of the receiver for controlling the behavior upon no video screen.

- **No-Video Screen:** Sets the display screen when there’s no live video source. Available options are Show CYP logo, No logo (black screen), and Show custom graphics. To upload a custom graphic file from your PC, click on “Choose File” to select the preferred graphic file (\*.JPEG format, 1280x720 max resolution, file size below 94.09KB) located on your local PC. After selecting the file, click the “Update” button to import the graphic.

- 3) **Scaler:** This section allows control over functions of the receiver for controlling the scaler/output resolution.

- **Scaler Output Mode:** Use the drop down list to select the preferred output resolution for the receiver’s scaler. Selecting one of the specific resolutions will output all video at that resolution. Selecting “Pass-Through” will output the source video at its original resolution with RGB colour space. Selecting “Pass-Through (Strict)” will output the source video at its original resolution. Selecting “Auto Detect (Per EDID)” will attempt to scale to the detected native resolution of the display connected to the HDMI output.

- 4) **USB over IP:** This section provides controls for the USB over IP extension functionality, including enabling/disabling USB support, changing the USB operational mode, and enabling special compatibility modes.

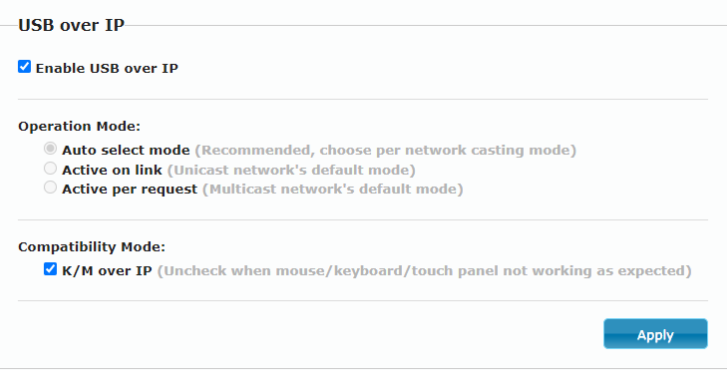

The screenshot shows a configuration window titled "USB over IP". It contains three sections: "Enable USB over IP" with a checked checkbox; "Operation Mode" with three radio button options: "Auto select mode (Recommended, choose per network casting mode)", "Active on link (Unicast network's default mode)", and "Active per request (Multicast network's default mode)"; and "Compatibility Mode" with a checked checkbox for "K/M over IP (Uncheck when mouse/keyboard/touch panel not working as expected)". An "Apply" button is located at the bottom right of the window.

- **Enable USB over IP:** Unchecking this checkbox will completely disable support for USB over this stream. This option should generally remain checked, but, if USB support is not required, disabling this feature can save some bandwidth.
- **Operation Mode:** Sets the USB extension mode. Available options are Auto, Active on link (Unicast optimised), and Active per request (Multicast optimised). Auto mode is set by default and will automatically select the correct mode depending on the broadcast mode of the unit.
- **Compatibility Mode:** These troubleshooting options enable specialised optimisations to solve issues when a mouse or touch panel is not responding properly.

- 5) **Serial over IP:** This section provides controls for the Serial over IP extension functionality, including enabling/disabling serial support and setting the RS-232 data configuration.

Serial over IP

Enable Serial over IP

---

**Baudrate Setting for Type 2:**

Baudrate:

Data bits:

Parity:

Stop bits:

---

- **Enable Serial over IP:** Unchecking this checkbox will completely disable support for sending RS-232 commands over this stream. This option should generally remain checked, but, if serial support is not required, disabling this feature can save a very small amount of bandwidth.
  - **Serial Settings:** Set the desired baud rate, data bits, parity, and stop bit for the RS-232 signal to extend.  
*Note: The transmitter and receiver must have the same serial settings.*
- 6) **Reboot:** Pressing this button will force the unit to reboot.

## 6.6 Telnet Control

Before attempting to use Telnet control, please ensure that both the unit and the PC are connected to the same active networks.

Start your preferred Telnet/Console client, or use the built in client provided by most modern computer operating systems. After starting the client, connect by using the current IP address of the unit and port 23 (if the communication port number used by the unit has not been changed previously). This will connect us to the unit we wish to control and commands may now be entered directly.

*Note 1: If the IP address of the unit is changed then the IP address required for Telnet access will also change accordingly.*

*Note 2: This unit defaults to Auto IP mode. The current IP address can be verified via the receiver's OSD if the Device Discovery software is not available. The default communication port is 23.*

## 6.7 Telnet Commands

COMMAND
Description and Parameters
<b>help</b> ↵ Show the full command list.
<b>help N1</b> ↵ Show help details about command <b>N1</b> . <b>N1</b> = {Any command name}
<b>get fw ver</b> ↵ Show the unit's current firmware version.
<b>get hw ver</b> ↵ Show the unit's current hardware version.
<b>get command ver</b> ↵ Show the unit's current command version
<b>get mac addr</b> ↵ Show the unit's MAC address.

COMMAND	
Description and Parameters	
<b>get model name</b> ←	Show the unit's model name.
<b>get model type</b> ←	Show the unit's product type.
<b>set factory default</b> ←	Reset the unit to the factory defaults.
<b>set factory ipconfig default</b> ←	Reset the unit's network settings to the factory defaults.
<b>get user config</b> ←	List the unit's current configuration information.
<b>set nickname N1</b> ←	Set the name of the unit's nickname.  Available values for <b>N1</b> : <b>N1</b> = {ASCII string}                      [Nickname]
<b>get nickname</b> ←	Show the name of the unit's nickname.
<b>set feedback broadcast N1</b> ←	Enable or disable the broadcast of console command feedback.  Available values for <b>N1</b> : ON    [Enabled] OFF    [Disabled]
<b>get feedback broadcast</b> ←	Show the current console command feedback broadcast state.
<b>set system reboot</b> ←	Reboot the unit.
<b>set uart 1 reset</b> ←	Reset the settings of the RS-232 port to the factory defaults.

COMMAND													
Description and Parameters													
<b>set uart 1 baudrate N1 ↵</b>	<p>Set the baud rate of the RS-232 port.</p> <p>Available values for <b>N1</b>:</p> <table border="0"> <tr> <td>4800</td> <td>[4800 baud]</td> </tr> <tr> <td>9600</td> <td>[9600 baud]</td> </tr> <tr> <td>19200</td> <td>[19200 baud]</td> </tr> <tr> <td>38400</td> <td>[38400 baud]</td> </tr> <tr> <td>57600</td> <td>[57600 baud]</td> </tr> <tr> <td>115200</td> <td>[115200 baud]</td> </tr> </table>	4800	[4800 baud]	9600	[9600 baud]	19200	[19200 baud]	38400	[38400 baud]	57600	[57600 baud]	115200	[115200 baud]
4800	[4800 baud]												
9600	[9600 baud]												
19200	[19200 baud]												
38400	[38400 baud]												
57600	[57600 baud]												
115200	[115200 baud]												
<b>get uart 1 baudrate ↵</b>	<p>Show the current baud rate of the RS-232 port.</p>												
<b>set uart 1 stop bit N1 ↵</b>	<p>Set the number of stop bits for the RS-232 port.</p> <p>Available values for <b>N1</b>:</p> <table border="0"> <tr> <td>1~2</td> <td>[Stop bits]</td> </tr> </table>	1~2	[Stop bits]										
1~2	[Stop bits]												
<b>get uart 1 stop bit ↵</b>	<p>Show the current number of stop bits of the RS-232 port.</p>												
<b>set uart 1 data bit N1 ↵</b>	<p>Set the data bits for the RS-232 port.</p> <p>Available values for <b>N1</b>:</p> <table border="0"> <tr> <td>5~8</td> <td>[Data bits]</td> </tr> </table>	5~8	[Data bits]										
5~8	[Data bits]												
<b>get uart 1 data bit ↵</b>	<p>Show the current number of data bits of the RS-232 port.</p>												

COMMAND	
Description and Parameters	
<b>set uart 1 parity N1</b> ↵	
Set the parity of the RS-232 port	
Available values for <b>N1</b> :	
0	[None]
1	[Odd]
2	[Even]
<b>get uart 1 parity</b> ↵	
Show the current parity setting of the RS-232 port.	
<b>set ip mode N1</b> ↵	
Set the unit's IP address assignment mode.	
Available values for <b>N1</b> :	
STATIC	[Static IP mode]
DHCP	[DHCP mode]
FORCE IP	[Auto IP mode]
<b>get ip mode</b> ↵	
Show the current IP address assignment mode.	
<b>get ipconfig</b> ↵	
Show the unit's current IP configuration information.	
<b>get ipaddr</b> ↵	
Show the unit's current IP address.	
<b>get netmask</b> ↵	
Show the unit's current netmask.	
<b>get gateway</b> ↵	
Show the unit's current gateway address.	
<b>set static ipaddr N1</b> ↵	
Set the unit's static IP address.	
<b>N1</b> = X.X.X.X	[X = 0~255, IP address]

COMMAND	
Description and Parameters	
<b>get static ipaddr</b> ↵	Show the unit's current static IP address.
<b>set static netmask N1</b> ↵	Set the unit's static netmask. <b>N1</b> = X.X.X.X [X = 0~255, Netmask]
<b>get static netmask</b> ↵	Show the unit's current static netmask.
<b>set static gateway N1</b> ↵	Set the unit's static gateway address. <b>N1</b> = X.X.X.X [X = 0~255, Gateway address]
<b>get static gateway</b> ↵	Show the unit's current static gateway address.
<b>get hostname</b> ↵	Show the unit's current hostname
<b>get out A color space</b> ↵	Show the colour space format currently used by the receiver's output. Possible response values: 0 [Unknown] 1 [RGB] 3 [YUV444] 4 [YUV422] 5 [YUV420]
<b>get out A type</b> ↵	Show the port type of the receiver's output.

**COMMAND****Description and Parameters****set out A resolution N1 ←**

Set the receiver's output resolution to use for the receiver's output.  
(For AVoIP transmitter used, it's minimum setting range are source timing/2)

Available values for **N1**:

pass-through	[pass through mode]
pass-through-strict	[pass through strict mode]
auto	[auto mode]
640x480p60	[640x480p60]
720x480p60	[720x480p60]
720x576p50	[720x576p50]
800x600p60	[800x600p60]
1024x768p60	[1024x768p60]
1280x720p50	[1280x720p50]
1280x720p60	[1280x720p60]
1280x768p60	[1280x768p60]
1280x800p60	[1280x800p60]
1280x1024p60	[1280x1024p60]
1360x768p60	[1360x768p60]
1366x768p60	[1366x768p60]
1440x900p60	[1440x900p60]
1400x1050p60	[1400x1050p60]
1600x900p60	[1600x900p60]
1600x1200p60	[1600x1200p60]
1680x1050p60	[1680x1050p60]
1920x1080p24	[1920x1080p24]
1920x1080p25	[1920x1080p25]
1920x1080p30	[1920x1080p30]
1920x1080p50	[1920x1080p50]
1920x1080p60	[1920x1080p60]
1920x1200p60	[1920x1200p60]
3840x2160p24	[3840x2160p24]
3840x2160p25	[3840x2160p25]
3840x2160p30	[3840x2160p30]
3840x2160p50	[3840x2160p50]
3840x2160p60	[3840x2160p60]
4096x2160p24	[4096x2160p24]
4096x2160p25	[4096x2160p25]
4096x2160p30	[4096x2160p30]

COMMAND	
Description and Parameters	
4096x2160p50	[4096x2160p50]
4096x2160p60	[4096x2160p60]
1280x720p25	[1280x720p25]
1280x720p30	[1280x720p30]
1280x960p60	[1280x960p60]
2560x1080p50	[2560x1080p50]
2560x1080p60	[2560x1080p60]
2560x1440p50	[2560x1440p50]
2560x1440p60	[2560x1440p60]
2560x1600p60	[2560x1600p60]
<b>get out A resolution</b> ←	
Show the output resolution string for the receiver's output.	
<b>set video wall layout N1 N2</b> ←	
Set the video wall's total horizontal and vertical display count on receiver.	
<b>N1</b> = 1~16	[Horizontal display count]
<b>N2</b> = 1~16	[Vertical display count]
<b>get video wall layout</b> ←	
Show the video wall's current total horizontal and vertical display count on receiver.	
<b>set video wall unit index N1</b> ←	
Set the video wall index number for the connected display on receiver. (Cannot exceed the video wall's horizontal and vertical display count.)	
<b>N1</b> = 0~255	[Index]
<b>get video wall unit index</b> ←	
Show the current video wall index number for the connected display on receiver.	
<b>set video wall default</b> ←	
Reset all video wall configuration values to their default settings on receiver.	

COMMAND	
Description and Parameters	
<b>set video wall project N1 N2 N3 N4</b> ↵	
Set the video wall's total horizontal (N1), vertical (N2) display count and position on receiver.	
<b>N1</b> = 1~16	[Horizontal display count]
<b>N2</b> = 1~16	[Vertical display count]
<b>N3</b> = 0~15	[Column]
<b>N4</b> = 0~15	[Row]
<b>set video wall position N1 N2</b> ↵	
Set the display's position within the video wall on receiver. (Cannot exceed the video wall's horizontal and vertical display count.)	
<b>N1</b> = 0~15	[Column]
<b>N2</b> = 0~15	[Row]
<b>get video wall position</b> ↵	
Show the display's position within the video wall on receiver.	
<b>set video wall bezel N1 N2 N3 N4</b> ↵	
Set the video wall display's bezel compensation values on receiver. (unit: 0.1mm)	
<b>N1</b> = 0~99999	[Total display width]
<b>N2</b> = 0~99999	[Video width]
<b>N3</b> = 0~99999	[Total display height]
<b>N4</b> = 0~99999	[Video height]
<b>get video wall bezel</b> ↵	
Show the video wall display's bezel compensation values on receiver. (unit: 0.1mm)	
<b>set warping keep aspect ratio N1</b> ↵	
Enable or disable the aspect ratio mode on receiver.	
Available values for <b>N1</b> :	
ON	[Fit In]
OFF	[Stretch Out]

COMMAND	
Description and Parameters	
<b>get warping keep aspect ratio</b> ←	
Show the current warping aspect ratio mode applied to a warped output on receiver.	
<b>set warping angle N1</b> ←	
Set the warping angle to apply to the receiver's output.	
Available values for <b>N1</b> :	
0	[0 Degrees]
90	[90 Degrees]
180	[180 Degrees]
270	[270 Degrees]
<b>get warping angle</b> ←	
Show the current warping angle applied to a warped output.	
<b>set audio out A mute N1</b> ←	
Enable or disable muting the receiver's audio output.	
Available values for <b>N1</b> :	
ON	[Mute]
OFF	[Unmute]
<b>get audio out A mute</b> ←	
Show the current mute state of the receiver's output.	
<b>set audio in 1 mute N1</b> ←	
Set the volume mute state for the audio input.	
Available values for <b>N1</b> :	
ON	[Mute]
OFF	[Unmute]
<b>get audio in 1 mute</b> ←	
Show the current volume mute state for the audio input.	
<b>get sink A edid data</b> ←	
Show the EDID from the display connected to the receiver's output as hex data.	

COMMAND	
Description and Parameters	
<b>set rx channel N1</b> ←	
Set the AVoIP channel to receive.	
<b>N1</b> = 0~255	[Transmission channel]
<b>get rx channel</b> ←	
Show the current AVoIP channel being received.	
<b>set rx id N1</b> ←	
Set receiver the id number for control system used.	
<b>N1</b> = 1~255	[ID Number]
<b>get rx id</b> ←	
Show the control system used id number on receiver.	
<b>set rx video channel N1</b> ←	
Set the specified AVoIP receiver's specified video channel.	
<b>N1</b> = 0~255	[Transmission channel]
<b>get rx video channel</b> ←	
Show the specified AVoIP receiver's specified video channel.	
<b>set showme N1</b> ←	
Enable or disable the unit's LEDs blinking to more easily visually identify the unit.	
Available values for <b>N1</b> :	
ON	[Enabled]
OFF	[Disabled]
<b>get showme</b> ←	
Show the current state of the showme function.	
<b>set stream cast mode N1</b> ←	
Set the AVoIP unit's network broadcast mode.	
Available values for <b>N1</b> :	
unicast	[Unicast Mode]
multicast	[Multicast Mode]

COMMAND	
Description and Parameters	
<b>get stream cast mode</b> ←←	
	Show the AVoIP unit's current network broadcast mode.
<b>set rx audio channel N1</b> ←←	
	Set the specified AVoIP receiver's specified audio channel.
<b>N1</b> = 0~255	[Transmission channel]
<b>get rx audio channel</b> ←←	
	Show the specified AVoIP receiver's specified audio channel.
<b>set rx uart channel N1</b> ←←	
	Set the specified AVoIP receiver's specified serial channel.
<b>N1</b> = 0~255	[Transmission channel]
<b>get rx uart channel</b> ←←	
	Show the specified AVoIP receiver's specified serial channel.
<b>set serial allow N1</b> ←←	
	Enable or disable the AVoIP serial route function.
	Available values for <b>N1</b> :
ON	[Enabled]
OFF	[Disabled]
<b>get serial allow</b> ←←	
	Show the serial over IP status.
<b>set rx ir channel N1</b> ←←	
	Set the specified AVoIP receiver's specified IR channel.
<b>N1</b> = 0~255	[Transmission channel]
<b>get rx ir channel</b> ←←	
	Show the specified AVoIP receiver's specified IR channel.

COMMAND					
Description and Parameters					
<b>set ir allow N1</b> ←	<p>Enable or disable the AVoIP ir route function.</p> <p>Available values for <b>N1</b>:</p> <table> <tr> <td>ON</td> <td>[Enabled]</td> </tr> <tr> <td>OFF</td> <td>[Disabled]</td> </tr> </table>	ON	[Enabled]	OFF	[Disabled]
ON	[Enabled]				
OFF	[Disabled]				
<b>get ir allow</b> ←	<p>Show the ir over IP status.</p>				
<b>set rx usb channel N1</b> ←	<p>Set the specified AVoIP receiver's specified USB channel.</p> <p><b>N1</b> = 0~255 [Transmission channel]</p>				
<b>get rx usb channel</b> ←	<p>Show the specified AVoIP receiver's specified USB channel.</p>				
<b>set tx usb use right N1</b> ←	<p>Send a request, from this receiver to the currently routed transmitter, for access rights to its USB stream.</p> <p>Available values for <b>N1</b>:</p> <table> <tr> <td>ON</td> <td>[Enabled]</td> </tr> <tr> <td>OFF</td> <td>[Disabled]</td> </tr> </table>	ON	[Enabled]	OFF	[Disabled]
ON	[Enabled]				
OFF	[Disabled]				
<b>set usb allow N1</b> ←	<p>Enable or disable the AVoIP USB route function.</p> <p>Available values for <b>N1</b>:</p> <table> <tr> <td>ON</td> <td>[Enabled]</td> </tr> <tr> <td>OFF</td> <td>[Disabled]</td> </tr> </table>	ON	[Enabled]	OFF	[Disabled]
ON	[Enabled]				
OFF	[Disabled]				
<b>get usb allow</b> ←	<p>Show the USB over IP status.</p>				

COMMAND	
Description and Parameters	
<b>set usb mode N1</b> ←	
Setting the AVoIP usb operation mode.(only setting on multicast mode)	
Available values for <b>N1</b> :	
0	[Active On Link]
1	[Active Per Request]
2	[Auto]
<b>get usb mode</b> ←	
Show the USB operation mode status.	
<b>set usb kmoip mode N1</b> ←	
Setting the AVoIP USB keyboard/mouse over IP mode.	
Available values for <b>N1</b> :	
ON	[Enabled]
OFF	[Disabled]
<b>get usb kmoip mode</b> ←	
Show the AVoIP USB keyboard/mouse over IP mode status.	
<b>set rx km roaming N1 N2 N3</b> ←	
Setting the AVoIP function of USB keyboard and mouse AV over IP to another receiver, and define the receiver's location.	
The command destination's receiver is at coordinate (0,0), other receiver's coordinate is the relative position to this receiver.	
<b>N1</b> = X.X.X.X	[X = 0~255, IP address of other receiver]
<b>N2</b> = -16~16	[Horizontal coordinates]
<b>N3</b> = -16~16	[Vertical coordinates]
<b>set video mute mode N1</b> ←	
Enable or disable the video mute function on receiver.	
Available values for <b>N1</b> :	
ON	[Enabled]
OFF	[Disabled]
<b>get video mute mode</b> ←	
Show the current state of the video mute function on receiver.	

COMMAND	
Description and Parameters	
<b>set video loss change time N1</b> ←	
Setting the timer of change to osd picture when detect video loss on transmitter.	
Available values for <b>N1</b> :	
61	[Always on]
1~60	[Seconds]
<b>get video loss change time</b> ←	
Show the setting timer for change to osd picture when detect video loss on transmitter.	
<b>set video loss screen N1</b> ←	
Enable/disable turn off screen on video lost on receiver.	
Available values for <b>N1</b> :	
ON	[Enabled]
OFF	[Disabled]
<b>get video loss screen</b> ←	
Show the setting for turn off screen on video lost on receiver.	
<b>set stop feature N1 N2</b> ←	
Enable/disable AVoIP stop feature on receiver.	
Available values for <b>N1</b> :	
video	[Video]
audio	[Audio]
ir	[IR]
usb	[USB]
serial	[Serial]
Available values for <b>N2</b> :	
ON	[Enabled]
OFF	[Disabled]

COMMAND	
Description and Parameters	
<b>get stop feature N1</b> ↵	
Show the setting for AVoIP stop feature on receiver.	
Available values for <b>N1</b> :	
video	[Video]
audio	[Audio]
ir	[IR]
usb	[USB]
serial	[Serial]
<b>set rx copy edid N1</b> ↵	
Enable/disable AVoIP the copy edid function on receiver.	
Available values for <b>N1</b> :	
ON	[Enabled]
OFF	[Disabled]
<b>get rx copy edid</b> ↵	
Show the setting for the copy edid on receiver.	
<b>set hotkey enable N1</b> ↵	
Enable/disable AVoIP Hotkey function.	
Available values for <b>N1</b> :	
ON	[Enabled]
OFF	[Disabled]
<b>get hotkey enable</b> ↵	
Show the hotkey enable status.	
<b>set control system ip N1</b> ↵	
Setting unit's control system IP address when using hotkey functions including: broadcast, video wall, and macro.	
<b>N1</b> = X.X.X.X	[X = 0~255, IP address of control system]
<b>get control system ip</b> ↵	
Show the unit's control system IP address.	

*Note: Commands will not be executed unless followed by a carriage return. Commands are case-sensitive and must be all caps.*

## 6.8 Hotkey Control

Some functions of this receiver can be controlled by using the OSD (On Screen Display) which is activated by pressing the preferred hotkey combination on USB keyboard, press it again to close the menu. Use the arrow keys, Tab key, or mouse to navigate the OSD menu. Press the ENTER key, SPACE key or mouse to confirm the selection.

*Note 1: Use command “set hotkey enable N1” (See section 6.7) to activate hotkey control.*

*Note 2: Use command “set control system ip N1” (See section 6.7) when using hotkey functions including: broadcast, video wall, and macro.*

HOTKEY LIST		
KEY COMBINATION	DESCRIPTION	KEY PRESS
Shift+Alt+L	<b>Link:</b> Route the receiver to the preferred transmitter.	Navigate: Arrow keys Confirm: Enter key
Shift+Alt+P	<b>Push:</b> Route the preferred receiver to the receiver’s current transmitter.	Navigate: Arrow keys Confirm: Enter key
Shift+Alt+G	<b>Get:</b> Route the receiver to the preferred receiver’s current transmitter.	Navigate: Arrow keys Confirm: Enter key
Shift+Alt+0~255	<b>Number:</b> Route the receiver to the preferred transmitter directly.	Confirm: Shift+Alt+End keys
Shift+Alt+B	<b>Broadcast:</b> Route the selected receiver group on the control system to the preferred transmitter.	Navigate: Arrow & Tab keys Checkbox: Enter key Tx-Name: alphabet & number keys Confirm: Space key
Shift+Alt+W	<b>Video Wall:</b> Route the selected video wall group on the control system to the preferred transmitter.	Navigate: Arrow & Tab keys Checkbox: Enter key Tx-Name: alphabet & number keys Confirm: Space key
Shift+Alt+M	<b>Macro:</b> Activate the preferred macro on the control system.	Navigate: Arrow keys Confirm: Enter key

HOTKEY LIST		
KEY COMBINATION	DESCRIPTION	KEY PRESS
Shift+Alt+S	<b>Search:</b> Refresh the hotkey menu.	
Shift+Alt+0~9	Enter the TX channel number to connect to (Press Shift+Alt+'End' for executing).	
Shift+Alt+'End'	Execute the channel switching.	

## 7. DANTE READY

### 7.1 Dante Ready Compatibility

#### Dante Overview

Dante is a network platform focusing on AV connectivity that's easy to use. It replaces all connections with a computer network, effortlessly sending video or hundreds of channels of audio over slender Ethernet cables with perfect digital fidelity. All connections are now managed with software, making routes fast, readable and reliable.

Because all devices share the same network, signals can be sent between any devices no matter where they are located on a site, with no change to the wiring at all. Dante systems are easily expanded, just connect additional devices to any available network jack and start using it.

#### Dante Ready Overview

Dante Ready provides a flexible way to enable and expand the connectivity and interoperability of the world's de-facto AV-over-IP solution, even after the initial purchase. Dante Ready is built within the widely used Dante Controller application for Dante audio and video subscription management. Transactions are simple and secure, and device upgrades are seamlessly actioned without the need to enter complex license keys of copy license files.

#### 7.1.1 Quick Walkthrough

- Step 1)** Make sure your computer and the Dante Ready device are both connected to the same network.
- Step 2)** Download and run Dante Controller (version 4.5 or later).  
Note: The latest version of Dante Controller can be download at [www.audinate.com](http://www.audinate.com).
- Step 3)** Open the Dante Activator tool from Dante Controller.
- Step 4)** Your device will be discovered, and you will see your purchase options.
- Step 5)** Add options to your cart, check out, then your device will be activated.
- Step 6)** Enjoy your additional Dante channels!

### 7.1.2 Online Activation

This section demonstrates the steps a user would follow to discover and activate their Dante Ready product. Screens are indicative and may differ from the latest version of the Dante Activator utility.

**Step 1)** Dante Activator can be found on the taskbar in Dante Controller. To launch, click the Dante Activator button . An orange notification dot is displayed when an upgrade has been detected for a device on the network.



**Step 2)** Under the “Devices” side-tab, products that have available activations, upgrades or recoverable licenses are displayed to the user. New Activations enables Dante on products where no functionality was present. The Upgrade Available list contains products where additional channels or features can be unlocked. Recoverable is a list of devices that have been identified as having previously been licenses. A device may appear here after a manufacturer’s ‘factory reset’.

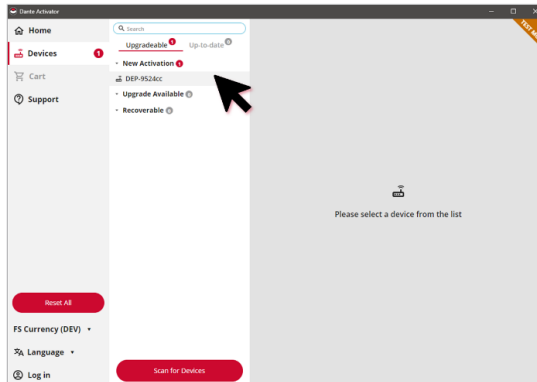

**Step 3)** Choosing a device will bring up the relevant Device Details page. The Device Details page outlines the activations and upgrades available for the device. Only one upgrade option is permitted. Prices are displayed in local currency.

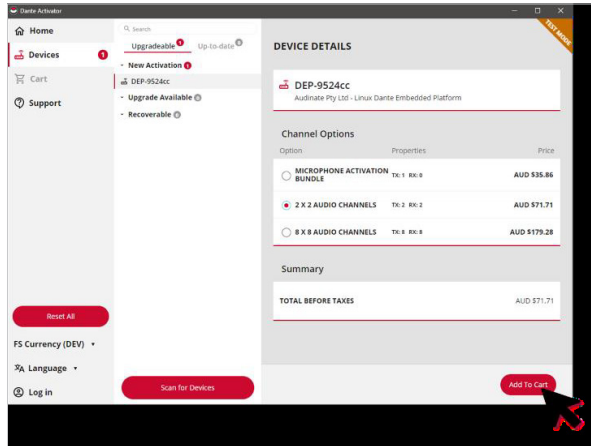

**Step 4)** Unless already logged in, users are required to log in to their audinate.com account to complete the transaction. This is the same account that used to download Dante Controller.

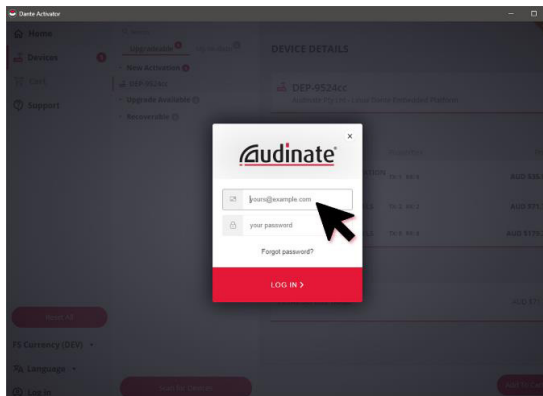

**Step 5)** A shopping cart summary is presented to allow the user to confirm the purchase. The shopping cart includes relevant local taxes.

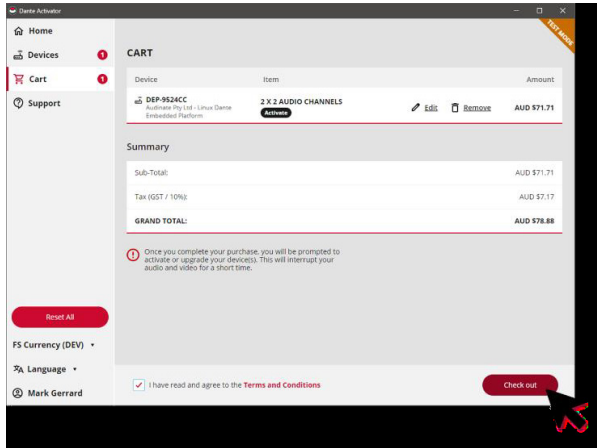

**Step 6)** Payment is via credit card or appropriate local payment method.

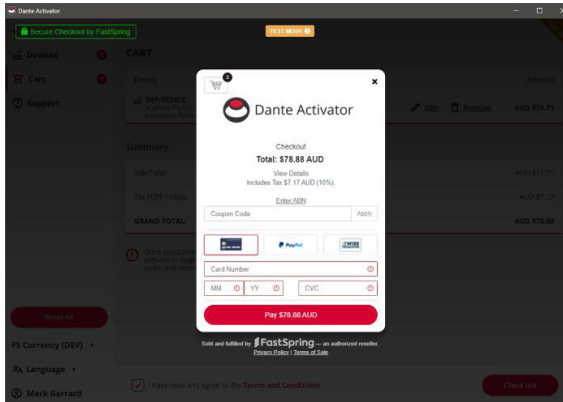

**Step 7)** Upon confirmation of the transaction, Dante Activator presents the purchased licenses and provides an option to activate the devices now. Clicking “Activate Now” will transfer the license to the local Dante device and instantly unlock the purchased features.

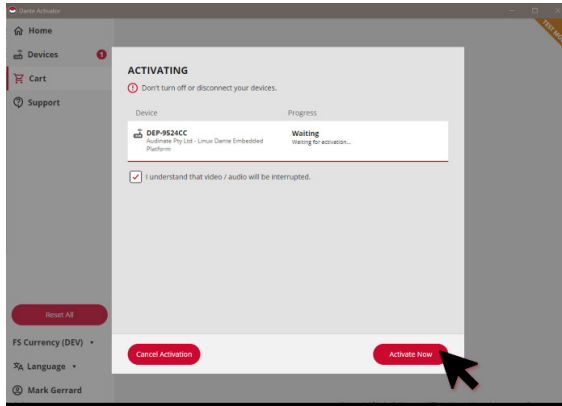

**Step 8)** Updates are shown in Dante Controller with new channels immediately available for subscriptions and routes.

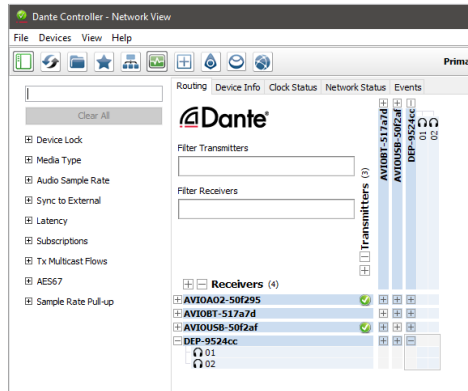

## 8. CONNECTION DIAGRAM

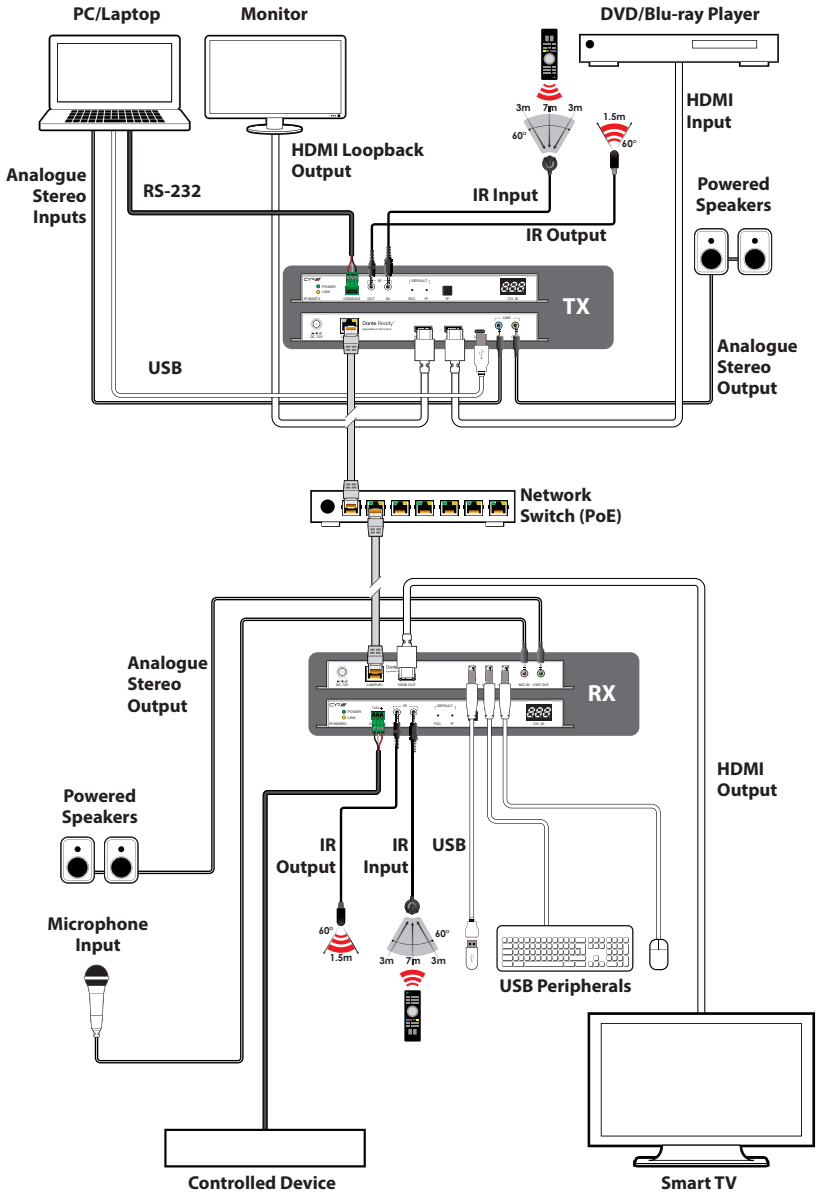

## 9. SPECIFICATIONS

### 9.1 Technical Specifications

<b>HDMI Bandwidth</b>	18Gbps
<b>Input Ports</b>	1×Mono Audio (3.5mm)
<b>Input/Control Port</b>	1×GbE LAN (RJ-45)
<b>Output Ports</b>	1×HDMI (Type-A) 1×Stereo Audio (3.5mm)
<b>Pass-through Ports</b>	1×IR Extender (3.5mm) 1×IR Blaster (3.5mm) 1×RS-232 (3-pin Terminal Block) 3×USB 2.0 (Type-A)
<b>IR Frequency</b>	30 ~ 50kHz (30 ~ 60kHz under ideal conditions)
<b>Baud Rate</b>	Up to 115200
<b>Power Supply</b>	12V/3A DC (US/EU standards, CE/FCC/UL certified)
<b>PoE Support</b>	802.3af minimum
<b>ESD Protection (HBM)</b>	±8kV (Air Discharge) ±4kV (Contact Discharge)
<b>Dimensions (W×H×D)</b>	231.5mm×25mm×108mm [Case Only] 231.5mm×25mm×120mm [All Inclusive]
<b>Weight</b>	660g
<b>Chassis Material</b>	Metal (Steel)
<b>Chassis Colour</b>	Black
<b>Operating Temperature</b>	0°C – 50°C/32°F – 122°F
<b>Storage Temperature</b>	-20°C – 60°C/-4°F – 140°F
<b>Relative Humidity</b>	20 – 90% RH (Non-condensing)
<b>Power Consumption</b>	17.68W

## 9.2 Video Specifications

Supported Resolutions (Hz)	Input	Output
	AVoIP	HDMI
<b>720×400p@70/85</b>	✓	✓
<b>640×480p@60/72/75/85</b>	✓	✓
<b>720×480i@60</b>	✓	✓
<b>720×480p@60</b>	✓	✓
<b>720×576i@50</b>	✓	✓
<b>720×576p@50</b>	✓	✓
<b>800×600p@56/60/72/75/85</b>	✓	✓
<b>848×480p@60</b>	✓	✓
<b>1024×768p@60/70/75/85</b>	✓	✓
<b>1152×864p@75</b>	✓	✓
<b>1280×720p@50/60</b>	✓	✓
<b>1280×768p@60/75/85</b>	✓	✓
<b>1280×800p@60/75/85</b>	✓	✓
<b>1280×960p@60/85</b>	✓	✓
<b>1280×1024p@60/75/85</b>	✓	✓
<b>1360×768p@60</b>	✓	✓
<b>1366×768p@60</b>	✓	✓
<b>1400×1050p@60</b>	✓	✓
<b>1440×900p@60/75</b>	✓	✓
<b>1600×900p@60RB</b>	✓	✓
<b>1600×1200p@60</b>	✓	✓
<b>1680×1050p@60</b>	✓	✓
<b>1920×1080i@50/60</b>	✓	✓
<b>1920×1080p@24/25/30</b>	✓	✓
<b>1920×1080p@50/60</b>	✓	✓
<b>1920×1200p@60RB</b>	✓	✓

Supported Resolutions (Hz)	Input	Output
	AVoIP	HDMI
<b>2560×1440p@60RB</b>	×	×
<b>2560×1600p@60RB</b>	×	×
<b>2048×1080p@24/25/30</b>	×	×
<b>2048×1080p@50/60</b>	×	×
<b>3840×2160p@24/25/30</b>	✓	✓
<b>3840×2160p@50/60 (4:2:0)</b>	✓	✓
<b>3840×2160p@24, HDR10</b>	✓	✓
<b>3840×2160p@50/60 (4:2:0),HDR10</b>	✓	✓
<b>3840×2160p@50/60</b>	✓	✓
<b>4096×2160p@24/25/30</b>	✓	✓
<b>4096×2160p@50/60 (4:2:0)</b>	✓	✓
<b>4096×2160p@24, HDR10</b>	✓	✓
<b>4096×2160p@50/60 (4:2:0),HDR10</b>	✓	✓
<b>4096×2160p@50/60</b>	✓	✓

## 9.3 Audio Specifications

### 9.3.1 Digital Audio

AV over IP Input / HDMI Output	
LPCM	
Max Channels	8 Channels
Sampling Rate (kHz)	32, 44.1, 48, 88.2, 96, 176.4, 192
Bitstream	
Supported Formats	Standard

### 9.3.2 Analogue Audio

Analogue Input	
Max Audio Level	300mVrms
Impedance	2.2k $\Omega$
Type	Unbalanced

Analogue Output	
Max Audio Level	2Vrms
THD+N	< -80dB@0dBFS 1kHz (A-wt)
SNR	> 80dB@0dBFS
Frequency Response	< $\pm 0.5$ dB@20Hz~20kHz
Crosstalk	< -80dB@10kHz
Impedance	200 $\Omega$
Type	Unbalanced

### 9.3.3 AVoIP Audio Availability

#### Unicast Data Transmission Mode:

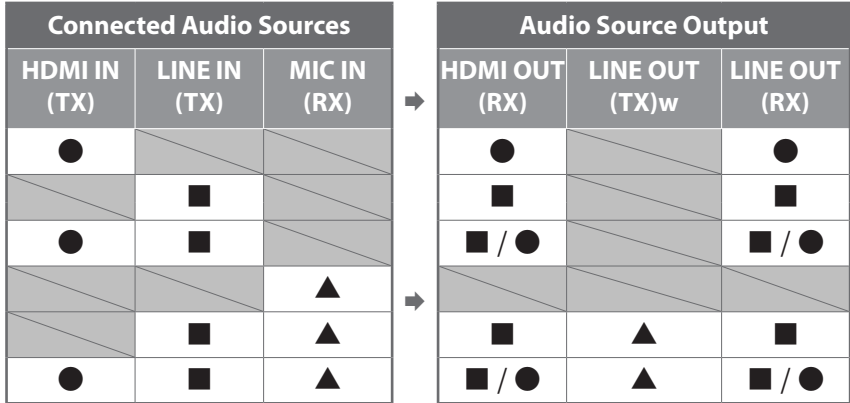

#### Multicast Data Transmission Mode:

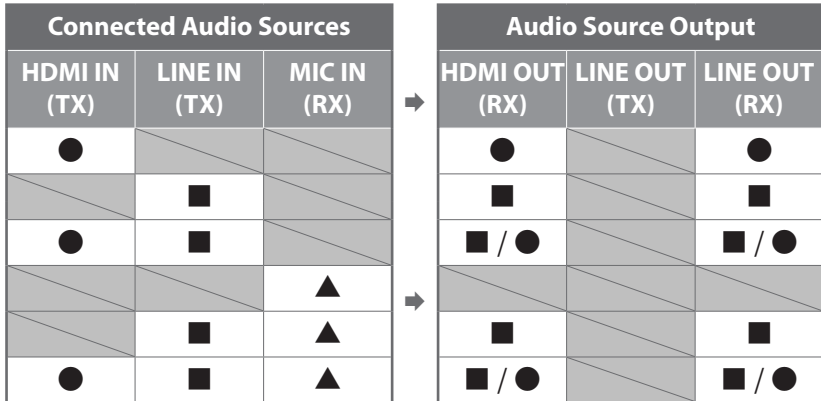

Legend:

- = HDMI audio source.
- = Line In (Transmitter) audio source.
- ▲ = Line In (Receiver) audio source.

## 9.4 Cable Specifications

Cable Length	HD	FHD	4K UHD	4K UHD <sup>+</sup>	8K UHD
<b>High Speed HDMI Cable</b>					
<b>HDMI Input</b>	15m	10m	5m	3m	×
<b>HDMI Output</b>	15m	10m	5m	3m	×
<b>Ethernet Cable</b>					
<b>Cat.5e/6</b>	100m				×
<b>Cat.6A/7</b>	100m				×

### Bandwidth Category Examples:

- **HD Video**
  - 720p@60Hz
  - HDMI transmission rates lower than 3Gbps
  - HD-SDI (SMPTE 292M, 1.485Gbps)
- **FHD Video**
  - 1080p@60Hz
  - HDMI transmission rates between 3Gbps and 5.3Gbps
  - 3G-SDI (SMPTE 424M, 2.970Gbps)
- **4K UHD Video**
  - 4K@24/25/30Hz (8-bit colour) & 4K@50/60Hz (4:2:0, 8-bit colour)
  - HDMI transmission rates between 5.3Gbps and 10.2Gbps
  - 6G-SDI (SMPTE ST 2081, 6Gbps)
- **4K UHD<sup>+</sup> Video**
  - 1080p@120Hz (10/12-bit HDR)
  - 4K@50/60Hz (4:4:4, 8-bit) & 4K@50/60Hz (4:2:0, 10/12-bit HDR)
  - HDMI transmission rates between 10.2Gbps and 18Gbps
  - 12G-SDI (SMPTE ST 2082, 12Gbps)
- **8K UHD Video**
  - 4K@120Hz (10/12-bit HDR)
  - 8K@24/25/30Hz (10/12-bit HDR) & 8K@50/60Hz (4:2:0, 8-bit colour)
  - HDMI transmission rates between 18Gbps and 48Gbps
  - 24G-SDI (SMPTE ST 2083, 24Gbps)

## 10. ACRONYMS

ACRONYM	COMPLETE TERM
<b>4K UHD</b>	4K Ultra-High-Definition (10.2Gbps max)
<b>4K UHD+</b>	4K Ultra-High-Definition (18Gbps max)
<b>ADC</b>	Analogue-to-Digital Converter
<b>ASCII</b>	American Standard Code for Information Interchange
<b>AV</b>	Audio/Video
<b>AVoIP</b>	Audio/Video over IP
<b>Cat.5e</b>	Enhanced Category 5 cable
<b>Cat.6</b>	Category 6 cable
<b>Cat.6A</b>	Augmented Category 6 cable
<b>Cat.7</b>	Category 7 cable
<b>CLI</b>	Command-Line Interface
<b>DAC</b>	Digital-to-Analogue Converter
<b>dB</b>	Decibel
<b>DHCP</b>	Dynamic Host Configuration Protocol
<b>DVI</b>	Digital Visual Interface
<b>EDID</b>	Extended Display Identification Data
<b>GbE</b>	Gigabit Ethernet
<b>Gbps</b>	Gigabits per second
<b>GUI</b>	Graphical User Interface
<b>HDCP</b>	High-bandwidth Digital Content Protection
<b>HDMI</b>	High-Definition Multimedia Interface
<b>HDR</b>	High Dynamic Range
<b>HID</b>	Human Interface Device
<b>HPD</b>	Hot Plug Detection
<b>IGMP</b>	Internet Group Management Protocol
<b>IP</b>	Internet Protocol
<b>IR</b>	Infrared

ACRONYM	COMPLETE TERM
<b>kHz</b>	Kilohertz
<b>LAN</b>	Local Area Network
<b>LED</b>	Light-Emitting Diode
<b>LPCM</b>	Linear Pulse-Code Modulation
<b>MAC</b>	Media Access Control
<b>MJPEG</b>	Motion JPEG
<b>MHz</b>	Megahertz
<b>OLED</b>	Organic Light-Emitting Diode
<b>OSD</b>	On-Screen Display
<b>PD</b>	Powered Device
<b>PoE</b>	Power over Ethernet
<b>PSE</b>	Power Sourcing Equipment
<b>SNR</b>	Signal-to-Noise Ratio
<b>TCP</b>	Transmission Control Protocol
<b>THD+N</b>	Total Harmonic Distortion plus Noise
<b>TMDS</b>	Transition-Minimised Differential Signaling
<b>UAC</b>	USB Audio Class
<b>USB</b>	Universal Serial Bus
<b>UVC</b>	USB Video Class
<b>VLAN</b>	Virtual LAN
<b>VoIP</b>	Video over IP
<b>XGA</b>	Extended Graphics Array
<b>Ω</b>	Ohm





---

CYP (UK) Ltd., Unit 7, Shepperton Business Park, Govett Avenue,  
Shepperton, Middlesex, TW17 8BA

Tel: +44 (0) 20 3137 9180 | Fax: +44 (0) 20 3137 6279

Email: [sales@cypeurope.com](mailto:sales@cypeurope.com)

[www.cypeurope.com](http://www.cypeurope.com)

v1.03