



PU-1H3HBTE

1 HDMI to 3 HDBaseT Splitter (100m) with HDMI bypass

OPERATION MANUAL



HDMI[®]
HIGH-DEFINITION MULTIMEDIA INTERFACE

The terms HDMI, HDMI High-Definition Multimedia Interface, and the HDMI Logo are trademarks or registered trademarks of HDMI Licensing Administrator, Inc.

DISCLAIMERS

The information in this manual has been carefully checked and is believed to be accurate. CYP (UK) Ltd assumes no responsibility for any infringements of patents or other rights of third parties which may result from its use.

CYP (UK) Ltd assumes no responsibility for any inaccuracies that may be contained in this document. CYP (UK) Ltd also makes no commitment to update or to keep current the information contained in this document.

CYP (UK) Ltd reserves the right to make improvements to this document and/or product at any time and without notice.

COPYRIGHT NOTICE

No part of this document may be reproduced, transmitted, transcribed, stored in a retrieval system, or any of its part translated into any language or computer file, in any form or by any means—electronic, mechanical, magnetic, optical, chemical, manual, or otherwise—without express written permission and consent from CYP (UK) Ltd.

© Copyright 2020 by CYP (UK) Ltd.

All Rights Reserved.

Version 1.1

TRADEMARK ACKNOWLEDGMENTS

All products or service names mentioned in this document may be trademarks of the companies with which they are associated.



SAFETY PRECAUTIONS

Please read all instructions before attempting to unpack, install or operate this equipment and before connecting the power supply. Please keep the following in mind as you unpack and install this equipment:

- Always follow basic safety precautions to reduce the risk of fire, electrical shock and injury to persons.
- To prevent fire or shock hazard, do not expose the unit to rain, moisture or install this product near water.
- Never spill liquid of any kind on or into this product.
- Never push an object of any kind into this product through any openings or empty slots in the unit, as you may damage parts inside the unit.
- Do not attach the power supply cabling to building surfaces.
- Use only the supplied power supply unit (PSU). Do not use the PSU if it is damaged.
- Do not allow anything to rest on the power cabling or allow any weight to be placed upon it or any person walk on it.
- To protect the unit from overheating, do not block any vents or openings in the unit housing that provide ventilation and allow for sufficient space for air to circulate around the unit.
- Please completely disconnect the power when the unit is not in use to avoid wasting electricity.

VERSION HISTORY

REV.	DATE	SUMMARY OF CHANGE
RDV1	2013/02/27	Preliminary Release
RDV2	2013/06/13	Package Contents
RDV3	2013/06/17	Dimension
RDV4	2013/06/20	Add IR Cable Pin Define
RDV5	2013/07/01	IR Power
VS1	2013/12/23	Updated Text & Diagrams

CONTENTS

1. Introduction	1
2. Applications	1
3. Package Contents	1
4. System Requirements	2
5. Features	2
6. Operation Controls and Functions	3
6.1 Front Panel	3
6.2 Rear Panel	4
6.3 IR Cable Pin Assignment	5
7. Connection Diagram	6
8. Specifications	7
8.1 Technical Specifications	7
8.2 CAT5e/6/7 Cable Specification	8
9. Acronyms	8

1. INTRODUCTION

The HDMI over HDMI and CAT5e/6/7 Splitter can split and distribute a single HDMI input, 2-way IR control and LAN serving to up to three CAT5e/6/7 outputs and includes a simultaneous HDMI bypass output. It supports resolutions up to 1080p Full HD, 4Kx2K timing, 3D and multi-channel digital audio formats (such as LPCM 7.1CH, Dolby TrueHD, Dolby Digital Plus and DTS-HD). The HDMI bypass output can be connected to an HDMI display or cascaded to another splitter. The three CAT5e/6/7 outputs can be connected to CAT5e/6/7 to HDMI receivers to extend the operating distance up to 100 metres.

Additionally, the LAN connectivity will allow a 100BaseT network to be served to smart TVs or games consoles. The Power over Ethernet (PoE) function can power compatible receivers, providing greater flexibility in installations.

2. APPLICATIONS

- /// Household entertainment sharing and control
- /// Lecture room display and control
- /// Showroom display and control
- /// Meeting room presentation and control
- /// Classroom display and control

3. PACKAGE CONTENTS

- /// HDMI over HDMI & CAT5e/6/7 with PoE and Ethernet Transmitter
- /// 1xIR Receiver
- /// 1xIR Blaster
- /// 24V DC Power Adaptor
- /// Power Cord
- /// Operation Manual

4. SYSTEM REQUIREMENTS

- /// HDMI equipped source devices, connect with HDMI cables
- /// HDMI equipped displays (TVs or monitors) or HDMI equipped AV receivers, connect with HDMI cables
- /// Certified CAT5e/6/7 cables

5. FEATURES

- /// HDMI with 4K×2K resolution and 3D support, HDCP and DVI compliant
- /// Simultaneous HDMI and CAT5e/6/7 outputs
- /// Supports data rate from 300 Mbps up to 3 Gbps
- /// Supports a wide range of PC resolutions from VGA to WUXGA (RB) and HDTV resolutions up to 4K×2K (3840×2160@30 Hz and 4096×2160@24 Hz)
- /// Supports transmission of High Definition audio: LPCM 7.1CH, Dolby TrueHD, Dolby Digital Plus and DTS-HD Master Audio (32 kHz~192 kHz sample rate)
- /// Supports distances up to 100 metres over CAT5e/6/7 cables
- /// Supports Ethernet network rates up to 100 Mbps
- /// Supports selection of Standard or TV EDID settings
- /// Supports PoE with compatible receiver units
- /// Supports control of devices via 2-way IR
- /// 3D signal display is dependent on the TV/Display's EDID settings

Note:

1. *This system was tested with CAT6/23AWG cables, results may vary with cables of a different specification.*
2. *The PoE function is designed for powering compatible Receiver units only, non-PoE Receivers will need their own power supply. Receivers of another brand may not be compatible.*
3. *For playback of 4K×2K HDMI source signals, a 4K×2K capable display and High Speed HDMI cables are required.*

6. OPERATION CONTROLS AND FUNCTIONS

6.1 Front Panel

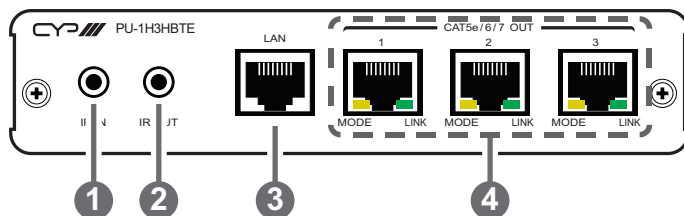

- 1 **IR IN:** Connect the supplied IR Receiver cable for IR signal reception. Ensure that remote being used is within the direct line-of-sight of the IR Extender.
- 2 **IR OUT:** Connect the supplied IR Blaster cable for IR signal transmission. Place the IR Blaster in direct line-of-sight of the equipment to be controlled.
- 3 **LAN:** Connect to an active network for LAN serving. When any compatible LAN equipped receivers are connected, this allows the network access (including internet access if available) to be shared. Connect any Ethernet equipped device e.g. a Smart TV or games console to the LAN port of a receiver for that device to share the network/internet access.

Warning: DO NOT connect the LAN connection with any of the CAT5e/6/7 outputs, doing so may trigger a power shut down and may damage the device.

- 4 **CAT5e/6/7 OUT 1~3:** Connect to CAT5e/6/7 to HDMI Receivers (with or without PoE) with a single CAT5e/6/7 cable each to extend the HDMI signal up to 100 m.

MODE LED: This LED will illuminate when the power is connected.

LINK LED: This LED will illuminate when connected to a Receiver unit that is connected to a TV/monitor that is displaying the signal.

6.2 Rear Panel

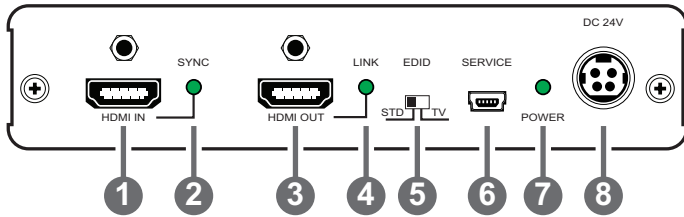

- 1 **HDMI IN:** Connect to HDMI equipped source equipment such as a DVD/Blu-ray player or games console.
- 2 **SYNC LED:** This LED will illuminate when the HDMI input is connected to a HDMI source and receiving a signal.
- 3 **HDMI OUT:** Connect to a HDMI display for local monitoring of the HDMI signal or cascade to another Splitter.
- 4 **HDMI LINK LED:** This LED will illuminate when HDMI output is connected to TV or display monitor and receiving a signal.
- 5 **EDID STD/TV:** The default setting is TV, when in this mode, the unit will detect the EDID settings of the display device connected to the CAT 5e/6/7 Output 1. If it detects a 4Kx2K capable EDID setting it will transmit the signal in that format to the output port. If no 4Kx2K capable EDID is detected then the unit will detect the EDID settings and send out the signal that all outputs can accept.

This device has a last memory function and will retain the EDID settings of the last device connected via the CAT5e/6/7 output port when it is not connected to a display after power cycling.

Switch to the STD setting to use the unit's built-in EDID if there are display problems. In this mode, the video output will be set to 1080p@60Hz and the audio at LPCM 2CH Stereo.

- 6 **SERVICE:** Reserved for manufacture use only.
- 7 **POWER LED:** The LED will illuminate when connected to an active power supply.
- 8 **DC 24V:** Connect the 24V DC power supply to the unit and plug the adaptor into an AC outlet.

6.3 IR Cable Pin Assignment

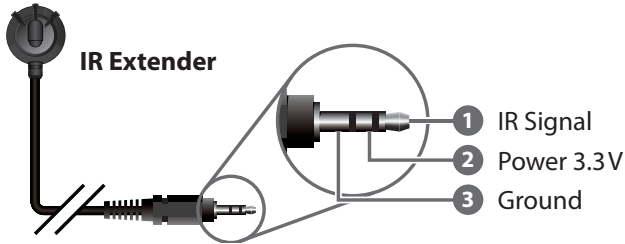
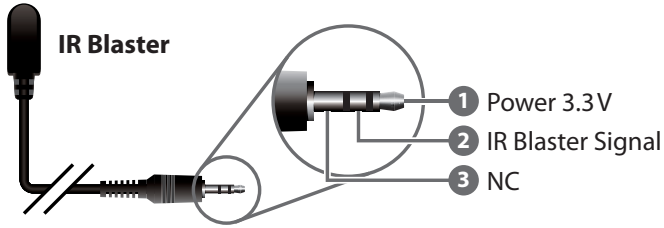

7. CONNECTION DIAGRAM

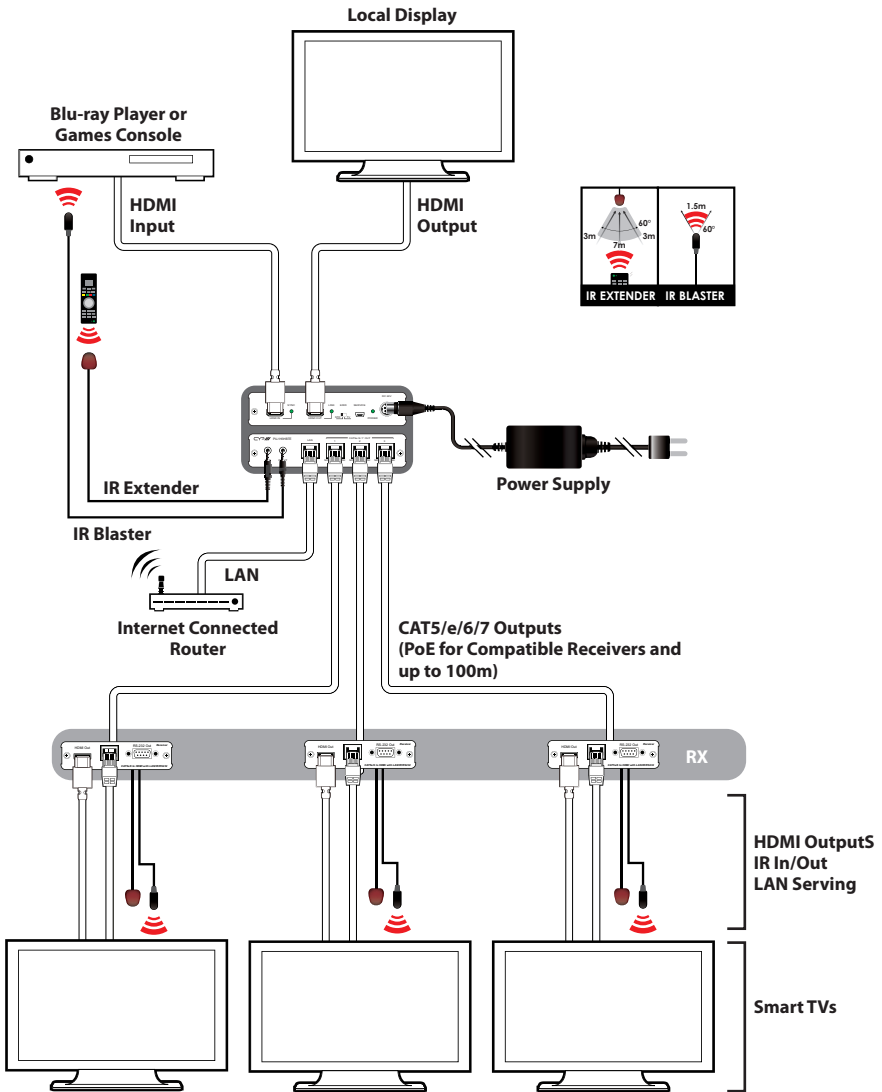

8. SPECIFICATIONS

8.1 Technical Specifications

Video Bandwidth	340 Mbps/10.2 Gbps
Input Ports	1×HDMI, 1×IR IN, 1×LAN, 1×USB (Service only)
Output Ports	1×HDMI, 3×CAT5e/6/7, 1×IR OUT
HDMI Supported Resolutions	480i~1080p@50/60 Hz, 1080p@24 Hz, 4K×2K (3840×2160@30 Hz/4096×2160@24/25Hz) & VGA~WUXGA (RB)
HDMI Input Cable Distance	10m (1080p@8/12-bit), 5m (4K×2K)
HDMI Output Cable Distance	15m (1080p@8-bit), 10m (1080p@12-bit), 10m (4K×2K)
IR Frequency	30~50 kHz
Power Supply	24V/2.7A DC (US/EU standards, CE/FCC/UL certified)
Dimensions	145 mm (W)×199 mm (D)×30 mm (H)
Weight	590 g
Chassis Material	Metal
Colour	Black
ESD Protection	Human body model: ±8kV (air-gap discharge) ±4kV (contact discharge)
Operating Temperature	0 °C ~ 40 °C
Storage Temperature	-20 °C ~ 60 °C / -4 °F ~ 140 °F
Relative Humidity	20 ~ 90 % RH (non-condensing)
Power Consumption	36 W

8.2 CAT5e/6/7 Cable Specification

CABLE TYPE	RANGE	PIXEL CLOCK RATE	VIDEO DATA RATE	SUPPORTED VIDEO
CAT5e/6/7	100 m	≤225 MHz	≤5.3 Gbps (HD Video)	Up to 1080p, 60 Hz, 36 bits, 3D (data rates lower than 5.3 Gbps or below 225MHz TMDS clock)
	70 m	>225 MHz	> 5.3 Gbps (Ultra HD Video)	4Kx2K, 30Hz video formats

9. ACRONYMS

ACRONYM	COMPLETE TERM
4Kx2K	Ultra High-Definition (3840x2160/4096x2160)
DTS	Digital Theater System
EDID	Extended Display Identification Data
HDCP	High-bandwidth Digital Content Protection
HDMI	High-Definition Multimedia Interface
HDTV	High-Definition Television



CYP (UK) Ltd., Unit 7, Shepperton Business Park, Govett Avenue,
Shepperton, Middlesex, TW17 8BA

Tel: +44 (0) 20 3137 9180 | Fax: +44 (0) 20 3137 6279

Email: sales@cypeurope.com

www.cypeurope.com

VS1