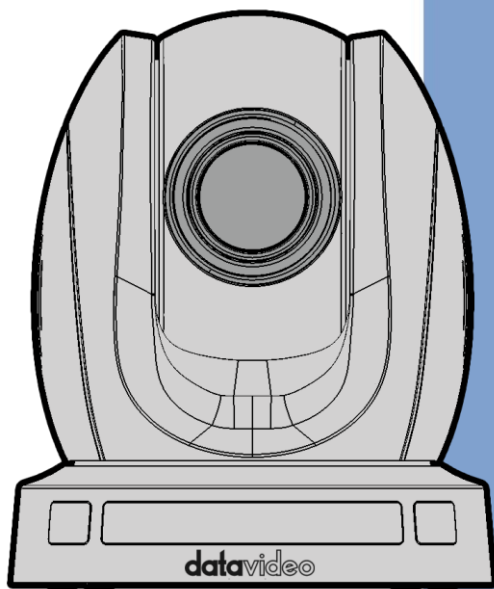


datavideo



HD TRACKING PTZ CAMERA

PTC-145

Instruction Manual

www.datavideo.com

Table of Contents

TABLE OF CONTENTS	2
FCC COMPLIANCE STATEMENT	5
WARNINGS AND PRECAUTIONS	5
WARRANTY	6
<i>STANDARD WARRANTY</i>	6
<i>THREE YEAR WARRANTY</i>	7
DISPOSAL	8
1. PRODUCT OVERVIEW	9
FEATURES	9
2. SYSTEM DIAGRAM	10
3. LOCATION AND FUNCTION OF PARTS	11
4. BASIC SETUP	15
4.1 INITIAL SETTING	15
4.2 VIDEO OUTPUT.....	15
<i>POE DVIP/LAN</i>	15
<i>HDMI Video Output</i>	16
<i>3G-SDI Video Output</i>	16
5. REMOTE CONTROL AND OSD MENU	17
5.1 REMOTE CONTROL FUNCTION	17
5.2 OSD MENU.....	22
6. HOW TO USE THE TALLY LIGHT OPTION IN THE OSD MENU	32
7. INSTALLATION INSTRUCTIONS	41
8. NETWORK CONNECTION	45
8.1 DHCP MODE.....	49
8.2 FIXED IP MODE	50
8.3 DVIP.....	51
9. PTC-145 WEB UI	55

9.1	CAMERA SETUP	55
	<i>CAMERA CONTROL</i>	56
	<i>Image Setting</i>	58
9.2	VIDEO OUTPUT.....	64
9.3	STREAM.....	64
	<i>Streaming to Facebook</i>	74
	<i>How to do the SRT Streaming by the vMix Software</i>	84
	<i>Multicast</i>	96
9.4	NETWORK.....	97
9.5	AUDIO.....	100
9.6	SYSTEM	102
9.7	AUTO TRACKING	105
10.	REMOTE CONTROL PORT PIN DEFINITIONS.....	109
11.	FIRMWARE UPDATE.....	111
	11.1 CHECK FIRMWARE VERSION	113
	11.2 BEFORE UPDATING THE FIRMWARE.....	116
	11.3 UPDATING THE MCU FIRMWARE	119
	11.4 UPDATING CAMERA AND AF FIRMWARE.....	121
12.	FREQUENTLY-ASKED QUESTIONS.....	123
13.	DIMENSIONS.....	125
14.	SPECIFICATIONS.....	126
	SERVICE AND SUPPORT	132

Disclaimer of Product and Services

The information offered in this instruction manual is intended as a guide only. At all times, Datavideo Technologies will try to give correct, complete and suitable information. However, Datavideo Technologies cannot exclude that some information in this manual, from time to time, may not be correct or may be incomplete. This manual may contain typing errors, omissions or incorrect information. Datavideo Technologies always recommend that you double check the information in this document for accuracy before making any purchase decision or using the product. Datavideo Technologies is not responsible for any omissions or errors, or for any subsequent loss or damage caused by using the information contained within this manual. Further advice on the content of this manual or on the product can be obtained by contacting your local Datavideo Office or dealer.

FCC Compliance Statement

This device complies with part 15 of the FCC rules. Operation is subject to the following two conditions:

- (1) This device may not cause harmful interference, and
- (2) This device must accept any interference received, including interference that may cause undesired operation.

Warnings and Precautions

1. Read all of these warnings and save them for later reference.
2. Follow all warnings and instructions marked on this unit.
3. Unplug this unit from the wall outlet before cleaning. Do not use liquid or aerosol cleaners. Use a damp cloth for cleaning.
4. Do not use this unit in or near water.
5. Do not place this unit on an unstable cart, stand, or table. The unit may fall, causing serious damage.
6. Slots and openings on the cabinet top, back, and bottom are provided for ventilation. To ensure safe and reliable operation of this unit, and to protect it from overheating, do not block or cover these openings. Do not place this unit on a bed, sofa, rug, or similar surface, as the ventilation openings on the bottom of the cabinet will be blocked. This unit should never be placed near or over a heat register or radiator. This unit should not be placed in a built-in installation unless proper ventilation is provided.
7. This product should only be operated from the type of power source indicated on the marking label of the AC adapter. If you are not sure of the type of power available, consult your Datavideo dealer or your local power company.
8. Do not allow anything to rest on the power cord. Do not locate this unit where the power cord will be walked on, rolled over, or otherwise stressed.
9. If an extension cord must be used with this unit, make sure that the total of the ampere ratings on the products plugged into the extension cord do not exceed the extension cord's rating.

10. Make sure that the total amperes of all the units that are plugged into a single wall outlet do not exceed 15 amperes.
11. Never push objects of any kind into this unit through the cabinet ventilation slots, as they may touch dangerous voltage points or short out parts that could result in risk of fire or electric shock. Never spill liquid of any kind onto or into this unit.
12. Except as specifically explained elsewhere in this manual, do not attempt to service this product yourself. Opening or removing covers that are marked “Do Not Remove” may expose you to dangerous voltage points or other risks, and will void your warranty. Refer all service issues to qualified service personnel.
13. Unplug this product from the wall outlet and refer to qualified service personnel under the following conditions:
 - a. When the power cord is damaged or frayed;
 - b. When liquid has spilled into the unit;
 - c. When the product has been exposed to rain or water;
 - d. When the product does not operate normally under normal operating conditions. Adjust only those controls that are covered by the operating instructions in this manual; improper adjustment of other controls may result in damage to the unit and may often require extensive work by a qualified technician to restore the unit to normal operation;
 - e. When the product has been dropped or the cabinet has been damaged;
 - f. When the product exhibits a distinct change in performance, indicating a need for service.

Warranty

Standard Warranty

- Datavideo equipment are guaranteed against any manufacturing defects for one year from the date of purchase.
- The original purchase invoice or other documentary evidence should be supplied at the time of any request for repair under warranty.

- The product warranty period begins on the purchase date. If the purchase date is unknown, the product warranty period begins on the thirtieth day after shipment from a Datavideo office.
- All non-Datavideo manufactured products (product without Datavideo logo) have only one year warranty from the date of purchase.
- Damage caused by accident, misuse, unauthorized repairs, sand, grit or water is not covered under warranty.
- Viruses and malware infections on the computer systems are not covered under warranty.
- Any errors that are caused by unauthorized third-party software installations, which are not required by our computer systems, are not covered under warranty.
- All mail or transportation costs including insurance are at the expense of the owner.
- All other claims of any nature are not covered.
- All accessories including headphones, cables, and batteries are not covered under warranty.
- Warranty only valid in the country or region of purchase.
- Your statutory rights are not affected.

Three Year Warranty

- All Datavideo products purchased after July 1st, 2017 are qualified for a free two years extension to the standard warranty, providing the product is registered with Datavideo within 30 days of purchase.
- Certain parts with limited lifetime expectancy such as LCD panels, DVD drives, Hard Drive, Solid State Drive, SD Card, USB Thumb Drive, Lighting, Camera module, PCIe Card are covered for 1 year.
- The three-year warranty must be registered on Datavideo's official website or with your local Datavideo office or one of its authorized distributors within 30 days of purchase.



Disposal



For EU Customers only - WEEE Marking

This symbol on the product or on its packaging indicates that this product must not be disposed of with your other household waste. Instead, it is your responsibility to dispose of your waste equipment by handing it over to a designated collection point for the recycling of waste electrical and electronic equipment. The separate collection and recycling of your waste equipment at the time of disposal will help to conserve natural resources and ensure that it is recycled in a manner that protects human health and the environment. For more information about where you can drop off your waste equipment for recycling, please contact your local city office, your household waste disposal service or the shop where you purchased the product.

1. Product Overview

The PTC-145 series is the continuation of the PTC-140 series and continues its high quality output specification with 20x optical zoom, which is suitable for auditoriums, classrooms, conference halls and other application scenarios. The built-in AI Tracking object tracking, which can be turned on instantly by the camera controller or the infrared remote control, operates the camera smoothly, and the push-pull-shift is natural without lagging.

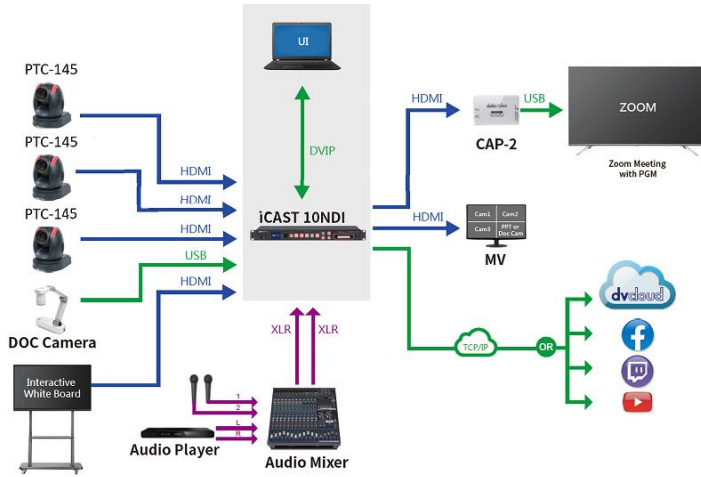
One time simultaneous output HDMI, 3G-SDI, streaming can be pushed to two platforms, encoding format support H.264, H.265, Motion JPEG, audio input support 3.5mm line in by the Web GUI direct switching. The PTC-145 can be integrated with on-site audio devices, and the standard PoE (IEEE802.3af) configuration makes power wiring simpler.

The PTC-145 is a series of products for different workflow requirements, and extensions such as the PTC-145T HDBaseT model and the NDI model are expected to be released from the end of 2022 to 2023.


Features

- HDMI/3G-SDI/Streaming Outputs
- PTZ camera with line in input
- One-touch activation of AI Tracking, smooth lens operation, no need for cameraman operation
- Streaming to two streaming platforms at a time
- 1/2.8" CMOS, 20x optical zoom, 8x digital zoom.
- Also available in white color to match interior design and decor

2. System Diagram



3. Location and Function of Parts

Front of Camera	
	
1	Lens HD color camera with built-in 1/2.8" 2.07 megapixel CMOS sensor with white balance control, backlight compensation setting, auto gain setting and other functions.
2	Tally LED When the tally signal is received, the tally lamp will light up.
3	Remote Control Sensor Infrared receiver for remote control.

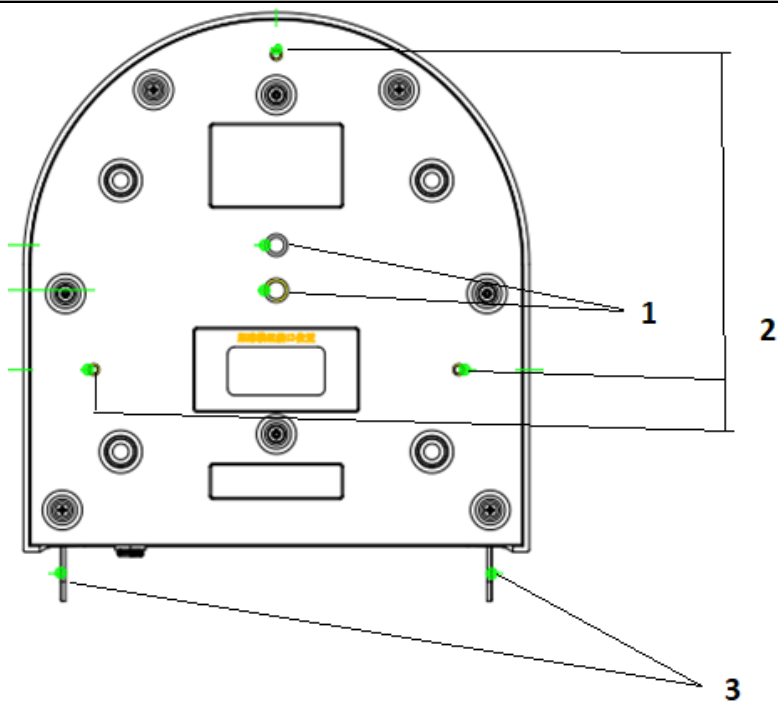
Rear of Camera



1	Power Input Port Connect the 12V power cord supplied with the product to the DC power port. The DC power adapter cable can be locked to the port using the outer ring locking mechanism.
2	POE DVIP/LAN Port The POE DVIP/LAN Port is a bi-directional port that allows you to connect the camera over a network. The POE DVIP/LAN port connects the camera to your computer over an Ethernet cable to monitor the camera images on the web user interface, and it also allows you to stream your camera images over a variety of streaming protocols.
3	HDMI OUT Port Connects an HDMI monitor externally via an HDMI cable.

4	<p>3G-SDI OUT Port Connects to an external SDI display via an SDI cable.</p>
5	<p>Audio Input 3.5mm audio input connector for external sound reception.</p>
6	<p>RS-422/RS-485 Interface (RJ-45) The RS-422/RS-485 interface connects to an external RS-422/RS-485 device. Use an Ethernet cable to connect to an external RS-422/RS-485 controller and refer to "Chapter 10 Remote Control Port Pin Definitions" for making the connection cable.</p>
7	<p>RS-232 Interface (RJ-45) The PTC-145 can be connected to a remote controller or computer via the RS-232 interface. Use an Ethernet cable to connect to an external RS-232 controller and refer to "Chapter 10 Remote Control Port Pin Definitions" for making the connection cable.</p>

Bottom of Camera



1

Tripod screw holes

Allows the user to mount the camera on a tripod.

2

Screw Holes

Screw holes for ceiling bracket installation.

3

For Safety Rope

Ties safety rope for fixing the camera to the ceiling.

4. Basic setup

4.1 Initial Setting

Insert the power cord into the power connection hole as shown in the following figure, and the Tally light in the front will start blinking red. The Tally lamp will stop blinking after the initialization is completed, and the camera head should be in the Home position with the lens facing forward. However, if you have set Preset 0, the camera head should return to the Preset 0 position.



Connects to a DC 12 V power adapter

4.2 Video Output

You can view camera images through the Ethernet port, HDMI video output port, and 3G-SDI video output port.

POE DVIP/LAN



Perform the following steps to view the camera image in the web user interface.

1. Connect the PTC-145 to a PC or laptop via an Ethernet cable.

2. Open a web browser on the connected PC or laptop and enter the camera's default IP address into the address bar.
Note: The default setting of PTC-145 is DHCP, if the camera is not assigned to an IP address, it will jump back to 192.168.100.100.
3. The login page of the Web UI will be opened and then please enter the user name and password (the default user name and password is admin/admin).
4. Open the preview window to preview the image frames taken by the camera.

HDMI Video Output



Connect the HDMI video output port to an external monitor via an HDMI cable.

3G-SDI Video Output

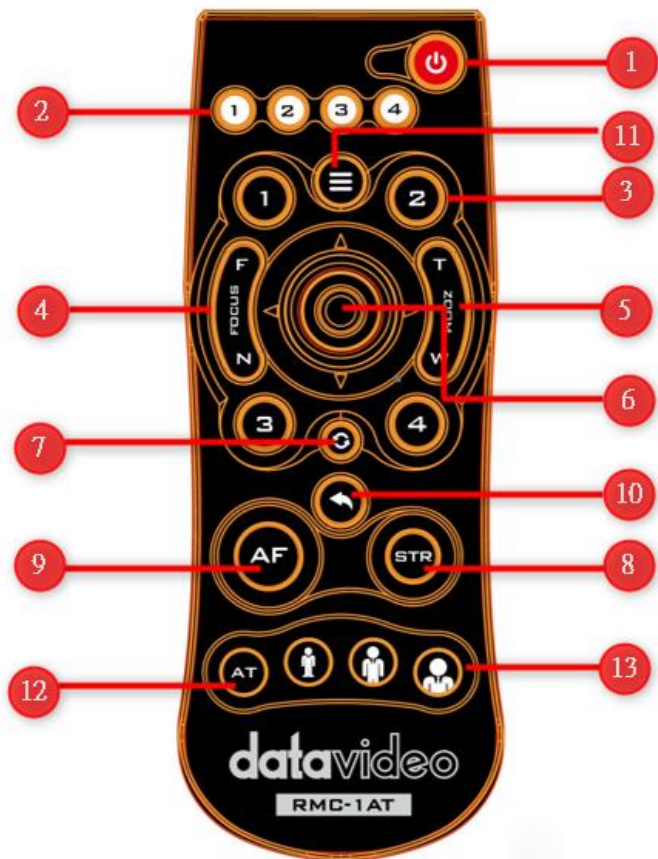





Connect the SDI video output port to the external monitor via the SDI cable.





5. Remote Control and OSD Menu






Chapter 5 introduces the remote control functions and OSD menus.


5.1 Remote Control Function



NO.	Function Keys	Descriptions
1	<p>Power Button</p> 	<p>Power button Tap this button once to enter standby mode. Tap it again to enter normal mode. Note: The power consumption in standby mode is about half of that in normal mode.</p>
2	<p>Camera 1-4</p> 	<p>Camera 1-4 The Camera 1~ Camera 4 buttons allow you to set your PTC-145 camera to be numbered 1-4.</p> <ul style="list-style-type: none"> ● A short press on the 1~4 button means selecting Camera 1, Camera 2, Camera 3 or Camera 4. ● After long press any key from Camera 1 to Camera 4, the four buttons will light up, then short press the numbering 1~4 buttons to complete the numbering setting of your camera.
3	<p>Prese1-4 Preset Keys</p> 	<p>The Preset 1, 2, 3, 4 preset buttons allow you to set up to 4 sets of camera presets.</p> <p>How to set Preset: After you have finished adjusting the camera parameters and lens position you want, press the "STR" button on the remote control, and then press the Preset number button (Preset 1-4) you want to save your settings as Preset settings.</p> <p>How to call out the preset setting: Please directly press the Preset number key (Preset 1-4) you want to call out, then you can call out the preset setting stored in advance.</p>

NO.	Function Keys	Descriptions
4	<p>Focus Far/ Focus Near</p> 	<p>Focus Far/Focus Near Press the "Focus Far" or "Focus Near" button to change the PTC-145 camera to Manual Focus mode. Focus Far allows you to focus far away and Focus Near allows you to focus close.</p>
5	<p>Zoom Tele/Zoom Wide</p> 	<p>Zoom Tele/Zoom Wide The Zoom Tele/Zoom Wide button allows you to manually zoom in and out of the subject. "Zoom Tele" allows you to zoom in on the subject and "Zoom Wide" allows you to zoom out.</p>
6	<p>Micro Joystick</p> 	<p>Micro Joystick: Up/Down/Left/Right/OK Move the Micro Joystick up/down/left/right to turn the camera lens up/down/left/right. When the OSD menu is open, move the Micro Joystick up/down to select different options. Move left/right to select different settings and press the Micro Joystick to confirm your selection.</p>
7	<p>Reset IP Key</p> 	<p>Reset IP Key The default setting of PTC-145 is DHCP, if the camera is not assigned to an IP, it will jump back to 192.168.100.100.</p>

NO.	Function Keys	Descriptions
8	<p>STR Button</p> 	<p>STR Button Pressing this button together with the Preset 1-4 button allows you to save your desired preset settings. After you have set the desired settings and camera lens position, press the "STR" button and then press the Preset 1-4 number you want to save to save the preset successfully.</p>
9	<p>AF Auto Focus button</p> 	<p>AF Auto Focus button Press this button to activate the AF autofocus function.</p>
10	<p>Back Button</p> 	<p>Back Button Pressing the Back button allows you to turn the camera lens back to the initial "Home" position. With the OSD open, pressing the Back button will take you back to the previous OSD menu.</p>
11	<p>Menu Button</p> 	<p>Menu Button Press the "Menu" button to open the OSD menu of the PTC-145 camera on an external screen.</p>
12	<p>AT Auto Tracking Button</p> 	<p>AT Auto Tracking Button Pressing this AT Auto Tracking button allows you to turn the camera's Auto Tracking feature on or off.</p>

NO.	Function Keys	Descriptions
13	<p data-bbox="250 161 389 209">Auto-tracking mode selector</p>  The image shows three circular icons on a black background, each with a white silhouette of a person. The first icon shows the full body, the second shows the waist up, and the third shows the head and shoulders. Each icon is highlighted with a yellow glow.	<p data-bbox="449 161 732 181">Auto-tracking mode selector</p> <p data-bbox="449 188 1020 272">These three buttons allow you to select the auto-tracking mode you want. From left to right, the three auto-tracking modes are "full body", "half body" and "close shot".</p>

5.2 OSD Menu

The OSD menu allows the user to change many of the camera's settings. Press the [MENU] button on the remote control to enter the OSD menu as shown below.

MENU
Language
Tracking
Setup
Camera
P/T/Z
Video Format
Network Settings
Version
Restore Default

[↑↓] (Select) [← →] (Change value)

[Menu] (Back) [Home] OK

The following table lists the options of the main menu and its sub-menu.

Main Options									
Language	Tracking	Setup	Camera	P/T/Z	Video Format	Network Settings	Version	Restore Default	
Sub-Options	English	Tracking	Protocol	Exposure	Spped by zoom	1080P60	DHCP	ARM	Restore Default
	Traditional Chinese		VISCA Address	Color	Zoom speed	1080P50	IP Addr	SOC	
	Simplified Chinese		VISCA Address Fix	Image	Image Freezing	1080I60		AF	
			PELCO-P Address	Focus	Acc Curve	1080I50			
			PELCO-D Address	Noise Reduction	Preset Speed	1080P30			
			Baudrate	Style	Joystick Pan Dir	1080P25			
			Auto Flip		Joystick Tilt Dir	720P60			
			TallyLight			720P50			
						1080P 59.94			
						1080I 59.94			
						1080P 29.97			
					720P 59.94				

The OSD menu options are listed below.

Main Menu	Sub Menu	Options	Options	
Language	English Traditional Chinese Simplified Chinese			
		Tracking	ON	
			OFF	
Tracking Mode	Presenter Tracking			
Tracking	Figure Size	Full		
		Customized		
		Half-Body		
		Close up		
	Full Presetting	1		
		2		
		3		
	Customized Presetting	1		
		2		
		3		
		4		
		5		
		6		
		7		
	8			
9				
Half-Body Presetting	1			
	2			
	3			
Near Body Presetting	1			
	2			
	3			
Track Speed	Slow			
	Fast			
	Middle			
Character Position	Center			
	Right Half			
	Left Half			
Setup	Protocol	Auto		
		VISCA		

		PELCOO-D	
		PELCCO-P	
	VISCA Address	1-7	
	VISCA Address Fix	ON/OFF	
	PELCO-P Address	1-255	
	PELCO-D Address	1-255	
	Baudrate	2400	
		4800	
		9600	
		38400	
		115200	
	Auto Flip	ON	
		OFF	
	Tally Light	RED/GREEN	
RED			
GREEN			
OFF			
Camera	Exposure	Mode	Auto
			Manual
			SAE
			AAE
			Bright
		EV	ON
			OFF
		EV Level	0
			1
			2
			3
			4
			5
			6
			7
			-7
			-6
			-5
		BLC	ON
			OFF
Flicker	OFF		
	50Hz		
	60Hz		

	G.Limit	0~15
	DRC	OFF
		1
		2
		3
		4
		5
		6
		7
	Iris	F1.8
		F2.0
		F2.4
		F2.8
		F3.4
		F4.0
		F4.8
		F5.6
		F6.8
		F8.0
		F9.6
		F11
	OFF	
	Shutter	1/60
		1/90
		1/100
		1/125
		1/180
		1/250
		1/350
		1/500
		1/725
		1/1000
		1/1500
		1/2000
		1/3000
		1/4000
		1/6000
	1/10000	
	Gain	0~36
	Bright	0~14
Color	WB Mode	Auto
		Manual
		Indoor
		Outdoor
		OnePush
		VAR
		2400K
		2500K

		2600K
		2700K
		2800K
		2900K
		3000K
		3100K
		3200K
		3300K
		3400K
		3500K
		3600K
		3700K
		3800K
		3900K
		4000K
		4100K
		4200K
		4300K
		4400K
		4500K
		4600K
		4700K
		4800K
		4900K
		5000K
		5100K
		5200K
		5300K
		5400K
		5500K
		5600K
		5700K
		5800K
		5900K
		6000K
		6100K
		6200K
		6300K
		6400K
		6500K
		6600K
		6700K
		6800K
		6900K
		7000K
		7100K
		0
		1
		2
		3
		4
	RG Tuning	

		180%
		190%
		200%
	Hue	0
		1
		2
		3
		4
		5
		6
		7
		8
		9
		10
		11
		12
		13
		14
		15
		-15
		-14
		-13
		-12
		-11
	-10	
	-9	
	-8	
	-7	
	-6	
	-5	
	-4	
	-3	
	-2	
	-1	
Image	Brightness	0~32
	Contrast	0~14
	Sharpness	0
		1
		2
		3
		4
		5
		6
7		
8		

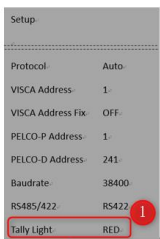
			9
			10
			11
		B&W-Mode	Color
			B&W
		DZoom	ON
		OFF	
	Focus	Focus Mode	Auto
			Manual
			OnePush
		AF-Zone	All
			Top
			Center
		Bottom	
	AF-Sensitivity	Low	
		Middle	
		High	
	Noise Reduction	NR-3D	OFF
			1
			2
3			
4			
5			
6			
7			
8			
9			
10			
11			
Style	Default		
	Meeting		
	Clarity		
	Bright		
	Soft		
P/T/Z	Speed by Zoom	ON	When turned on, Zoom will gradually accelerate and decelerate.
		OFF	
	Zoom Speed	1	
		2	
		3	
		4	
		5	
		6	
	7		
	8		
Image Freezing	ON		
	OFF		
Acc Curve	Standard		

		Slow		
		Fast		
	Preset Speed		Fast	
			Slow	
			Middle	
	Joystick Pan Dir		Positive	
		Negative		
Joystick Tilt Dir		Positive		
		Negative		
Video Format	1080P60			
	1080P50			
	1080I60			
	1080I50			
	1080P30			
	1080P25			
	720P60			
	720P50			
	1080P59.94			
	1080I59.94			
	1080P29.97			
	720P59.94			
Network Settings	DHCP	ON		
		OFF		
	IP Addr	192.168.100.100 (If DHCP is OFF)		
Version	ARM			
	SOC			
	AF			
Restore Default	Restore Default (YES/NO)			

6. How to use the Tally Light option in the OSD menu

The "Tally Light" option in the PTC-145 OSD menu allows you to determine whether the camera's Tally light will illuminate in red or green depending on the settings of the "PVW (green when pressed)" and "PGM (red when pressed)" buttons on the PTC-145 camera when it is connected to the a switcher (take the SHOWCASE 100 as an example.) First of all, please press the "MENU" button on the PTC-145 remote control to open the OSD menu, then go to "Setup>Tally Light" option to select your desired Tally light setting. There are 4 options for you to choose, including "RED", "GREEN", "RED/GREEN" and "OFF".

- **When the "Tally Light" option on the OSD menu is set to "RED"**
 - The "PVW" and "PGM" (channel 1 for example) of the switcher are not selected, that is, they are both set to "OFF", and the Tally lamp of the camera will not be lit at this time. The following is a schematic diagram



Please select "RED" for the Tally Light option.



Please set the "PGM" and "PVW" to "OFF".



The Tally light of the camera will not be lit.

- Switcher's "PVW" is set to "ON" and the "PGM" is set to "OFF" (take channel 1 as an example). At this time, the tally light of the camera will not be lit. The diagram below is a schematic diagram.



- Switcher's "PGM" is set to "ON" and the "PVW" is set to "OFF" (take channel 1 as an example). At this time, the tally light of the camera will be lit in red. The diagram below is a schematic diagram.



- Switcher's "PGM" is set to "ON" and the "PVW" is set to "ON" (take channel 1 as an example). At this time, the tally light of the camera will be lit in red. The diagram below is a schematic diagram.



- **When OSD Menu's "Tally Light" option is set in "GREEN"**

- No input source is selected by the switcher's "PVW" and "PGM" (take channel 1 as an example), which means that the "PVW" and "PGM" channels are "OFF". At this time, the camera's tally light will not be lit. The diagram below is a schematic diagram.



- Switcher's "PGM" is set to "OFF" and the "PVW" is set to "ON" (take channel 1 as an example). At this time, the tally light of the camera will be lit in green. The diagram below is a schematic diagram.



- Switcher's "PGM" is set to "ON" and the "PVW" is set to "OFF" (take channel 1 as an example). At this time, the tally light of the camera will not be lit. The diagram below is a schematic diagram.



- Switcher's "PGM" is set to "ON" and the "PVW" is set to "ON" (take channel 1 as an example). At this time, the tally light of the camera will be lit in green. The diagram below is a schematic diagram.



- **When OSD Menu's "Tally Light" option is set in "RED" / "GREEN"**

- No input source is selected by the switcher's "PVW" and "PGM" (take channel 1 as an example), which means that the "PVW" and "PGM" channels are "OFF". At this time, the camera's tally light will not be lit. The diagram below is a schematic diagram.



- Switcher's "PGM" is set to "OFF" and the "PVW" is set to "ON" (take channel 1 as an example). At this time, the tally light of the camera will be lit in green. The diagram below is a schematic diagram.



- Switcher's "PGM" is set to "ON" and the "PVW" is set to "OFF" (take channel 1 as an example). At this time, the tally light of the camera will be lit in red. The diagram below is a schematic diagram.



- Switcher's "PGM" is set to "ON" and the "PVW" is set to "ON" (take channel 1 as an example). At this time, the tally light of the camera will be lit in red. The diagram below is a schematic diagram.

SETUP	
Protocol	Auto
Visca Address	1
Visca Address Fix	OFF
PELCO-P Address	1
PELCO-D Address	241
Baudrate	38400
RS-485/RS-422	RS422
Tally Light	RED/GREEN



Please select "RED/GREEN" for the Tally Light option.

Please select the "PGM" to "ON" and "PVW" to "ON"

The Tally light of the camera will be lit in red

- **When OSD Menu's "Tally Light" option is set in "OFF"**

- No input source is selected by the switcher's "PVW" and "PGM" (take channel 1 as an example), which means that the "PVW" and "PGM" channels are "OFF". At this time, the camera's tally light will not be lit. The diagram below is a schematic diagram.

SETUP	
Protocol	Auto
Visca Address	1
Visca Address Fix	OFF
PELCO-P Address	1
PELCO-D Address	241
Baudrate	38400
RS-485/RS-422	RS422
Tally Light	OFF



Please select "OFF" for the Tally Light option

Please select the "PGM" to "OFF" and "PVW" to "OFF"

The Tally light of the camera will not be lit.

- Switcher's "PGM" is set to "OFF" and the "PVW" is set to "ON" (take channel 1 as an example). At this time, the tally light of the camera will not be lit. The diagram below is a schematic diagram.



- Switcher's "PGM" is set to "ON" and the "PVW" is set to "OFF" (take channel 1 as an example). At this time, the tally light of the camera will not be lit. The diagram below is a schematic diagram.



- Switcher's "PGM" is set to "ON" and the "PVW" is set to "ON" (take channel 1 as an example). At this time, the tally light of the camera will not be lit. The diagram below is a schematic diagram.

SETUP	
Protocol	Auto
Visca Address	1
Visca Address Fix	OFF
PELCO-P Address	1
PELCO-D Address	241
Baudrate	38400
RS-485/RS-422	RS422
Tally Light	OFF

Please select "OFF" for the Tally Light option



Please select the "PGM" to "ON" and "PVW" to "ON"



The Tally light of the camera will not be lit.

7. Installation Instructions

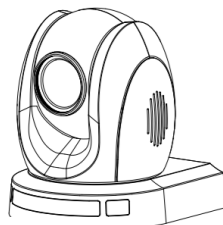
Note: Only mount the bracket on formwork or concrete surface. Do NOT mount the bracket on plasterboard.

In your product package, you should find

- PM3*5 screw x 6
- Ceiling bracket (upper and lower plates) x 1
- PTC-145 camera x 1



Ceiling Bracket (Upper and Lower Plates)



PM3*5 Screw x 6

Additionally, you will also need the following to secure the ceiling bracket to the ceiling:

- PA4*30 self-tapping screw x 4
- PA4 plastic screw stopper x 4



PA4*30 Self-tapping Screw x 4



PA4 Plastic Screw Stopper x 4

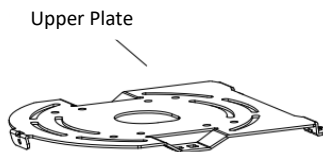
Step 1: The Ceiling Bracket

Separate the ceiling bracket into two parts (upper and lower plates) as depicted in the diagram below.

STEP 1



Ceiling Bracket



Upper Plate



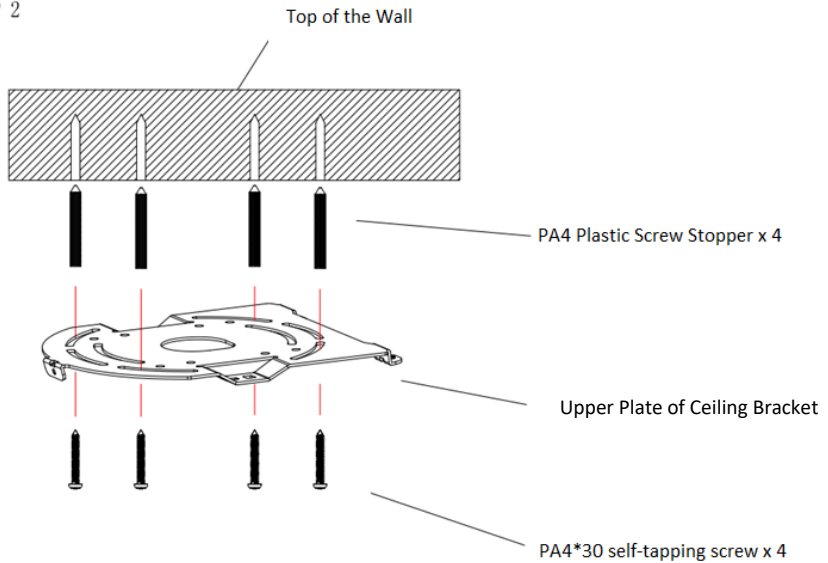
Lower Plate

Step 2: Mount the bracket's upper plate to the ceiling

Insert the four PA4 plastic screw stoppers into the ceiling as shown in the diagram below.

Using four PA4*30 self-tapping screws, affix the bracket's upper plate to the ceiling.

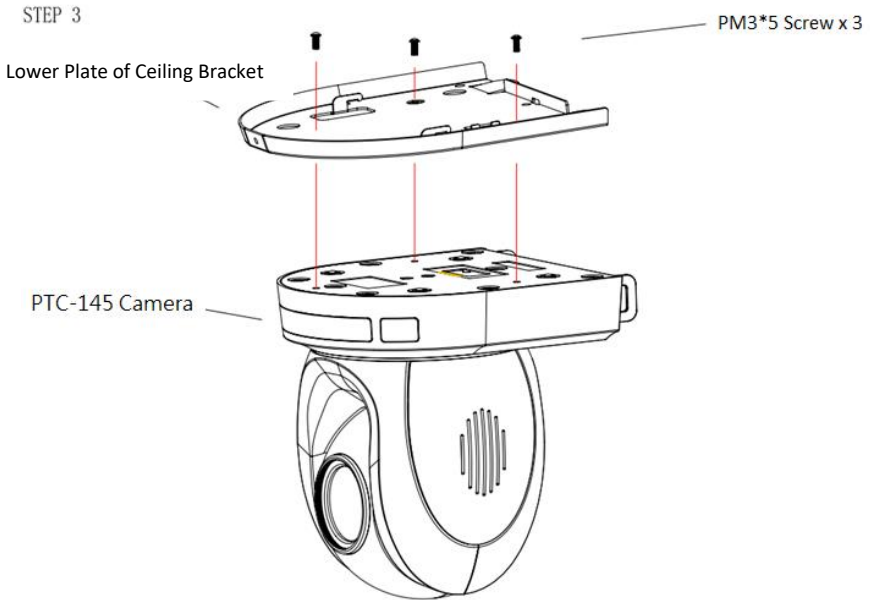
STEP 2



Step 3: Affix the bracket's lower plate to the bottom of PTC-145

As depicted in the diagram below, use three PM3*5 screws to affix the bracket's lower plate to the bottom of PTC-145.

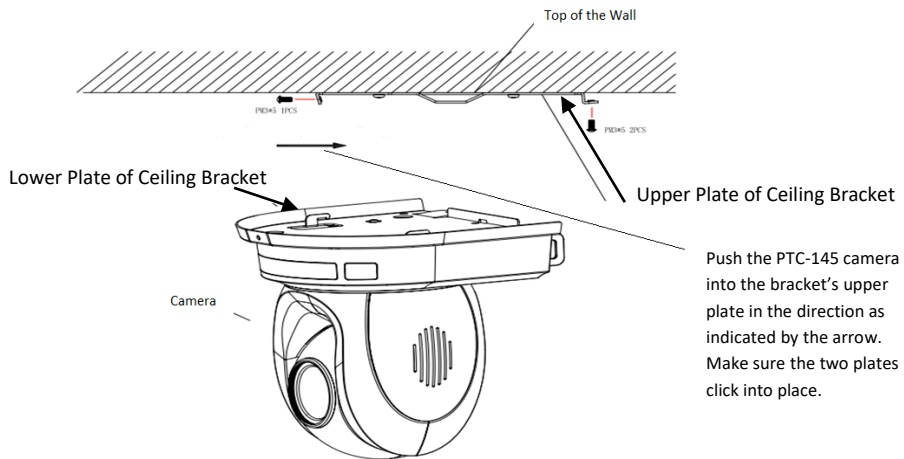
STEP 3



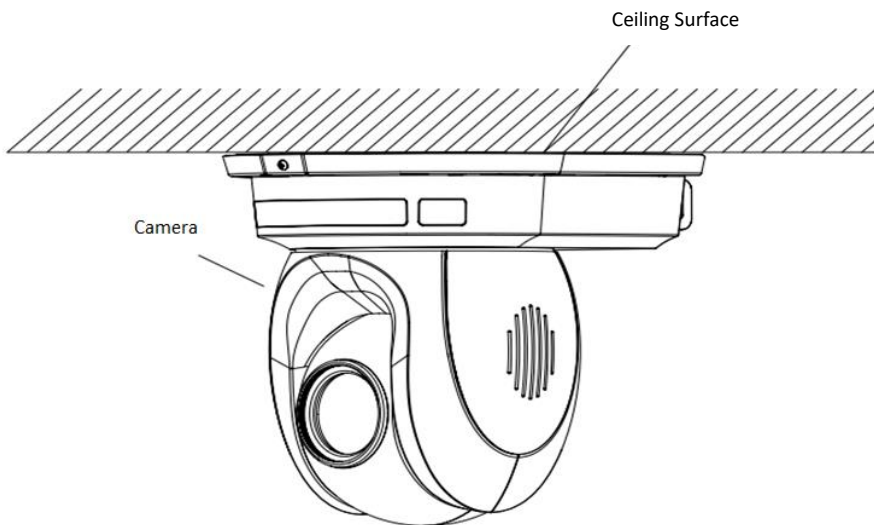
Step 4: Mount the PTC-145 Camera to the ceiling

Now push the PTC-145 camera into the bracket's upper plate in the direction as indicated by the arrow in the diagram below. Make sure the two plates click into place.

Finally, secure the PTC-145 camera to the upper plate with three PM3*5 screws.



Step 5: Final



8. Network Connection

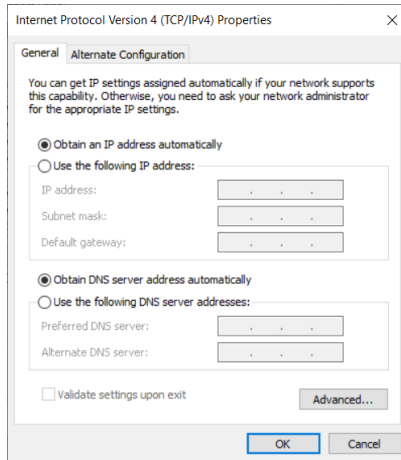
The Ethernet port on the back of the PTC-145 allows you to connect your computer to the camera via a fixed IP or DHCP connection. The PTC-145 is factory defaulted to DHCP mode. To access and modify network settings, you must first log in to the camera's web user interface.

If this is your first time using the camera, the default fixed IP address should be 192.168.100.100.

As shown in the figure below, please connect your PTC-145 camera and laptop to a router with an RJ-45 Ethernet cable.

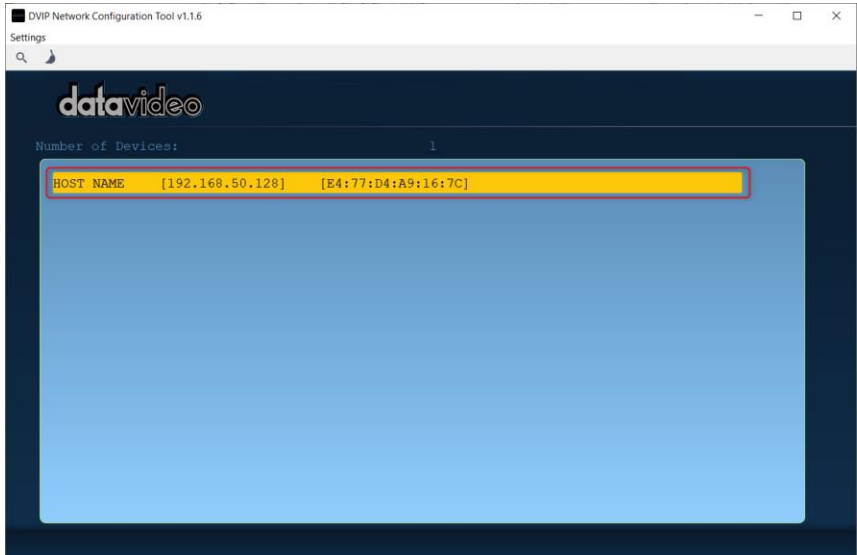


Please go to the PTC-145 product page on Davideo's website <https://www.datavideo.com/product/PTC-145> to download and install the DVIP Network Configuration Tool. Make sure your laptop or computer is also set to DHCP mode.

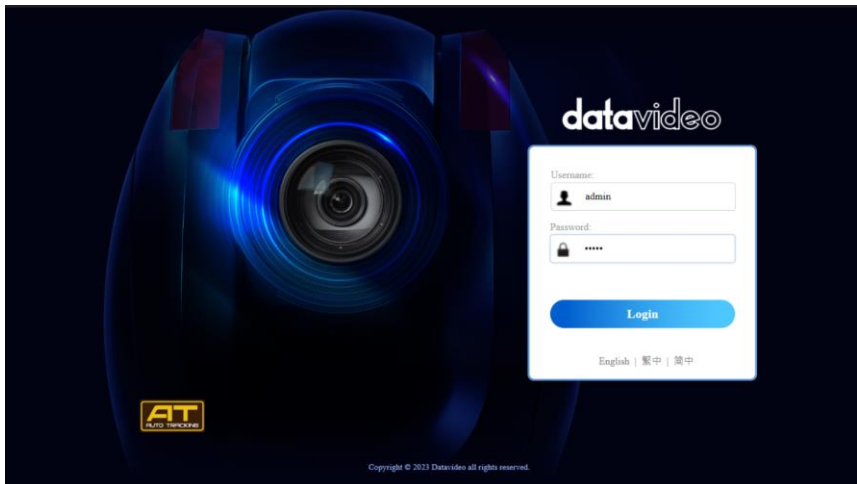


Please use DVIP Network Configuration Tool to find out the IP address of PTC-145.





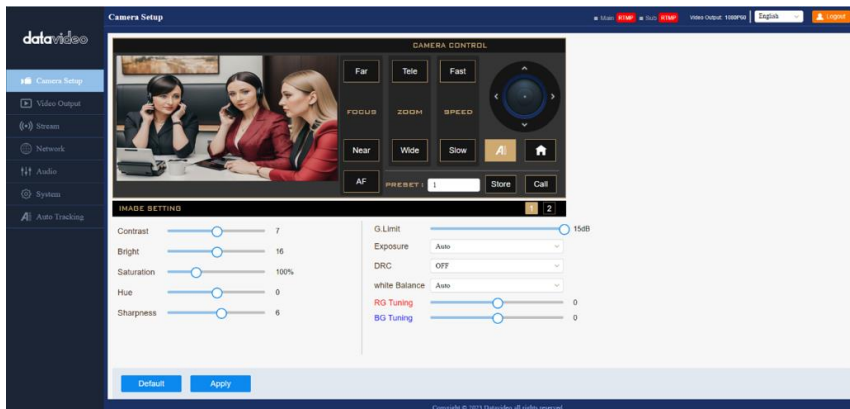
Open a web browser on your computer and enter the PTC-145's DHCP dynamic IP address, in this case 192.168.50.128, into the address bar, then press the Enter key on your keyboard to open the web user interface's login page.



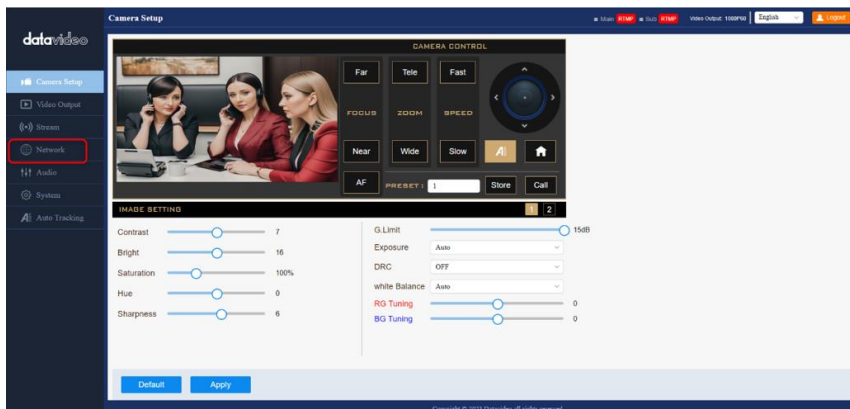
The following are the default login username and password :

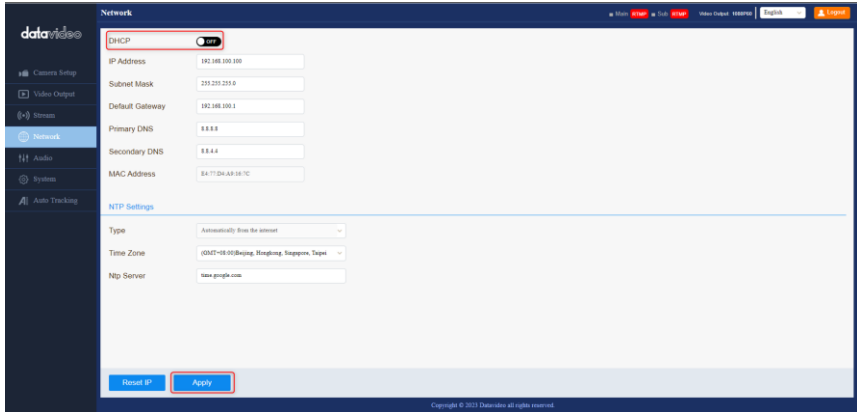
- Username: admin
- Password: admin

After successfully logging in to the web user interface, you should see the following camera screen.



Click the "Network" option on the left side of the web user interface to enter the "Network" interface. You can utilize the "DHCP" ON/OFF switch and click the "Apply" button to set your camera's connection mode to DHCP mode or Fixed IP mode. To reset the IP mode of the PTC-145 to the factory default setting, press the "Default" button. The PTC-145 is factory defaulted to DHCP mode.





In the next two chapters, we will introduce how to turn on DHCP for the camera and the Fixed IP Connection mode separately.

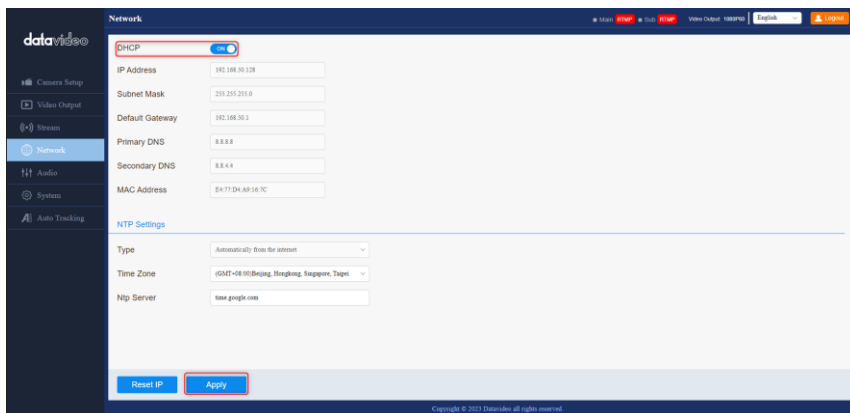
Note: To log out of the web user interface, click "Logout" at the top right of the page. 

8.1 DHCP Mode

DHCP, or Dynamic Host Configuration Protocol, is a network protocol that enables a server to automatically assign IP addresses within a domain to all devices connected to the network. The following is an example of a DHCP network connection.

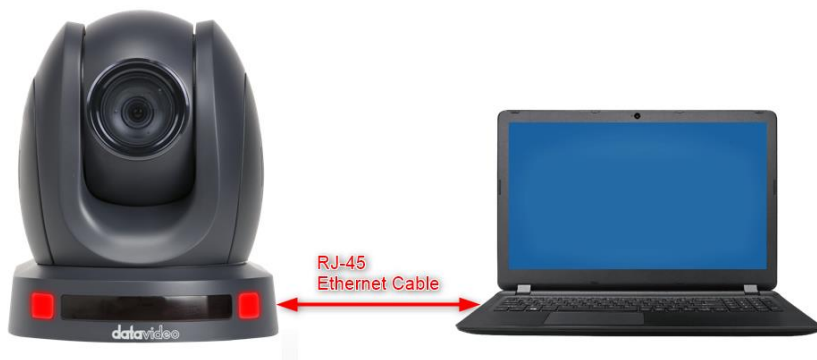


To turn on the DHCP mode of the camera, log in to the Web UI, click the "Network" option on the left side of the Web UI to enter the "Network" interface, and then click the "DHCP" ON/OFF switch to set it as "DHCP ON", and then press the "Apply" button, the PTC-145 will reboot itself automatically and set your PTC-145 to DHCP mode.



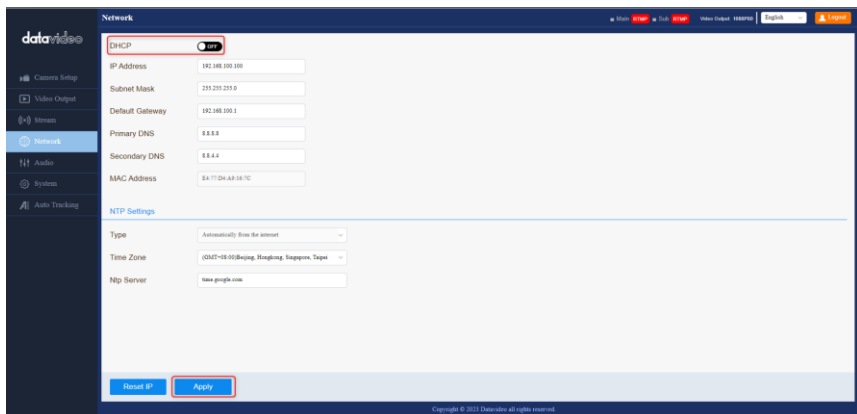
8.2 Fixed IP Mode

To enable Fixed IP Mode for the camera, connect your computer or laptop directly using an RJ-45 Ethernet cable and set it to the same domain.



Since the PTC-145 is defaulted to DHCP mode, please log in to the Web UI in DHCP mode, click the "Network" option on the left side of the Web UI to enter the "Network" interface, and then click the "DHCP" ON/OFF switch to set it as

"DHCP OFF", and set up your desired fixed IP address and information in the options of "IP Address", "Subnet Mask", "Default Gateway", "Primary DNS" and "Secondary DNS", and click the "Apply" button to reboot the PTC-145. And then the PTC-145 will then set your PTC-145 to the Fixed IP Mode. Then you can connect your PTC-145 to a computer or laptop on the same domain and enter the fixed IP address into the web browser address bar to open the PTC-145 Web UI, taking the fixed IP address "192.168.100.100" as an example.



Note: When assigning an IP address, avoid trailing .0 or .255 because .0 or .255 is usually reserved for network protocols, and the first IP address in the IP range is not recommended because the first IP address is usually reserved for the router.

8.3 DVIP

DVIP is a network setup utility that searches for DVIP devices connected to the same domain. Network items that can be configured include Device Name, DHCP mode, IP address, Submask, Gateway IP, and Primary and Secondary DNS.

You can select the DVIP download point and install it according to the operating system you are using.

PC: <https://www.microsoft.com/en-us/p/dvip-network-config/9p6gtz839k6s?activetab=pivot%3Aoverviewtab>

Android:

https://play.google.com/store/apps/details?id=com.datavideo.dvipnetconfig&hl=en_US

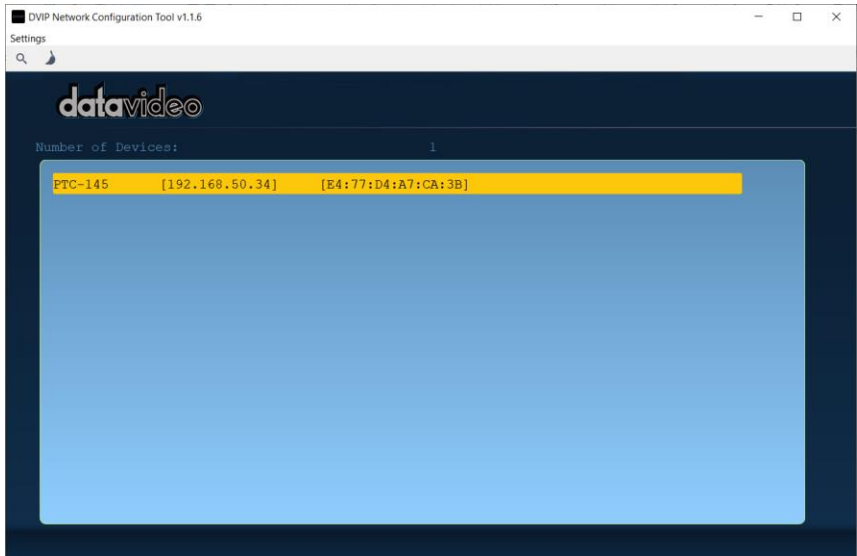
iOS: <https://itunes.apple.com/tw/app/dvip-network-config/id1177895983?mt=8>

After installing the DVIP Network Configuration Tool, follow the steps below to search for connected DVIP devices and enter the relevant settings.

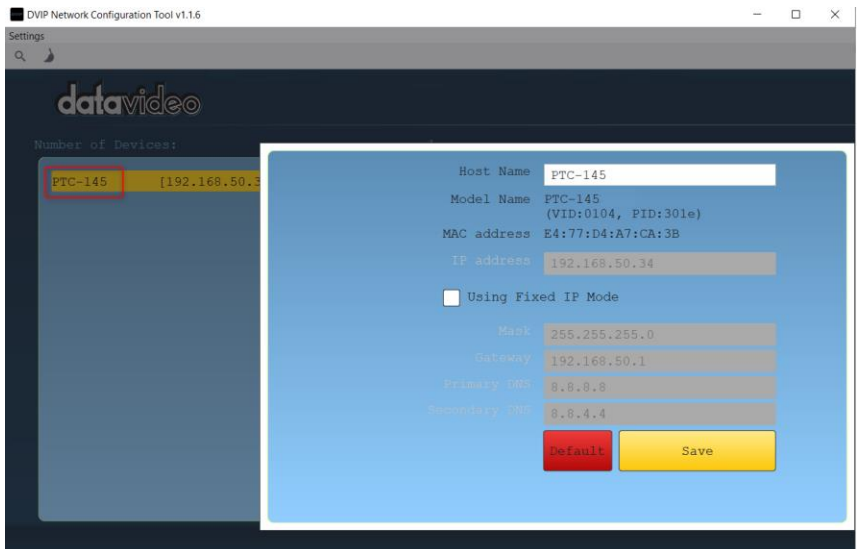
Step 1: Open the DVIP Network Configuration Tool and select the Ethernet option you are connecting to from the "Network Interface" pop-up window and click the "OK" button.



Step 2: After selecting your network interface, the DVIP Network Configuration Tool interface will be displayed as shown below.



Step 3: Click "PTC-145" to display the Network Setup pop-up window



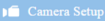
Step 4: User can click "Host Name" to change the device name. If necessary, users can also click on the settings to change the value, then click "Save" to save the settings, and click "Default" to restore the default value.

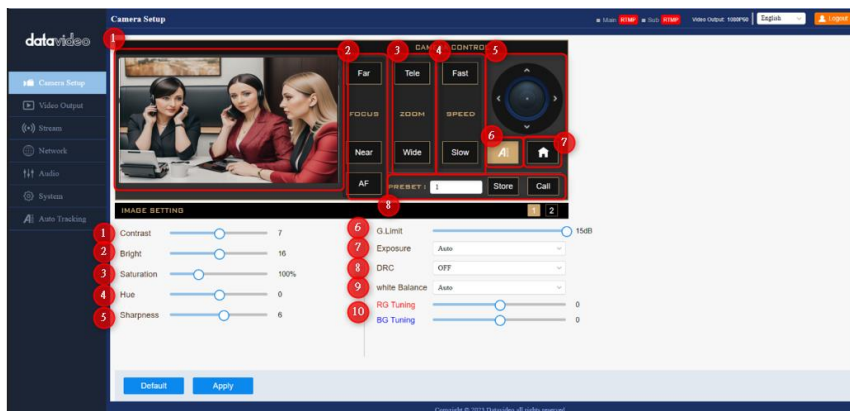
Host Name	PTC-145
Model Name	PTC-145NDI (VID:0104, PID:301e)
MAC address	E4:77:D4:A7:CA:3B
IP address	192.168.50.34
<input type="checkbox"/> Using Fixed IP Mode	
Mask	255.255.255.0
Gateway	192.168.50.1
Primary DNS	8.8.8.8
Secondary DNS	8.8.4.4
Default	Save

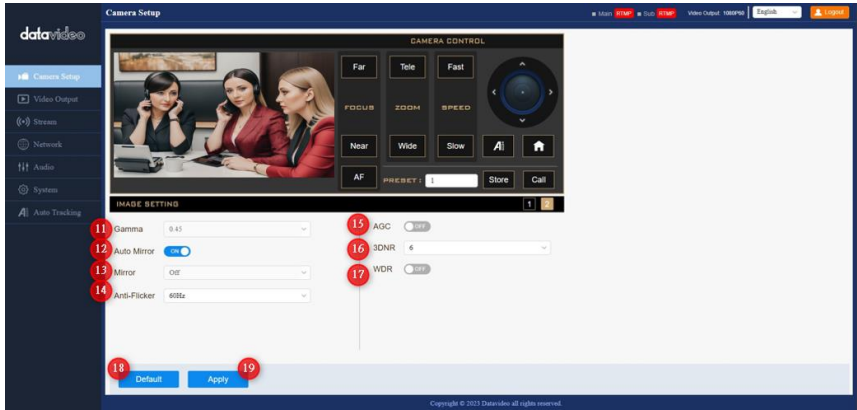
9. PTC-145 Web UI

A web-based user interface allows you to configure and operate the PTC-145 unit.

9.1 Camera Setup


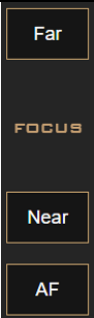


The "Camera Setup" option  allows users to see a preview of what the camera will capture on the Web UI. In addition, it also allows users to control camera control parameters such as "Focus", "Zoom", "Speed (Pan/Tilt speed)", "Enable/Disable AI auto-tracking", "Return camera lens to home position", "Save/Retrieve presets", and so on. In addition, there are camera control parameters including "Contrast", "Brightness", "Saturation", "Hue", "Sharpness", "G.Limit", "Exposure", "DRC", "White Balance", "RG Tuning", "BG Tuning", "Gamma", "Auto Mirror ON/OFF Switch", "Mirror", "Anti-flicker", "AGC" ON/OFF Switch, "3DNR" and "WDR" ON/OFF switches are available for users to adjust. The "Camera Settings" interface is shown below.



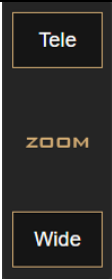










CAMERA CONTROL

For "Camera Control" related functions, see the table below.

	Function Keys	Descriptions
1		<p>Live Image Preview Window</p> <p>This live image preview window allows you to preview the live images taken by the camera.</p>
2		<p>Focus</p> <p>The Focus option allows the user to adjust the focus point.</p> <ul style="list-style-type: none">  AF: Press the "AF" button to apply the "AF AUTO FOCUS" setting.  MF: When the camera is in AF mode, press the "AF" button to switch to MF manual focus mode

	Function Keys	Descriptions
		<p>and use the "Focus Far"  and "Focus Near"  buttons to adjust the focus manually.</p>
3		<p>Zoom The Zoom option allows users to adjust the Zoom Tele and Zoom Wide of the camera lens. You can press the Tele button  and Wide button  to zoom the camera lens in and out respectively.</p>
4		<p>Speed The Speed option allows the user to adjust the Pan, Tilt, Focus and Zoom speed of the camera lens. Pressing the Fast button  increases the speed and pressing the Slow button  decreases the speed.</p>
5		<p>Virtual joystick (up/down/left/right) Users can use this virtual joystick to control the Panning and Tilting of the camera lens, push the virtual joystick up/down/left/right to control the Pan, Tilt direction of the camera lens.</p>







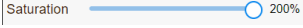
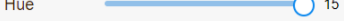


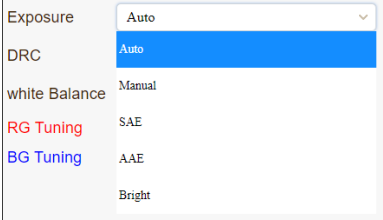
	Function Keys	Descriptions
6		<p>AI auto-tracking function on/off key</p> <p>Press the "AI" button  to toggle between turning the AI auto-tracking feature on or off.</p>
7		<p>Home</p> <p>Pressing this "Home" button returns the camera lens to its starting position.</p>
8		<p>Preset storage and call keys</p> <p>The PTC-145 has 255 presets (0 - 254). Enter the preset number you wish to save into the "PRESET" field and press the "SAVE" button to save the preset. Enter the preset number you want to recall into the "PRESET" field and press the "CALL" button to recall the preset you want.</p>


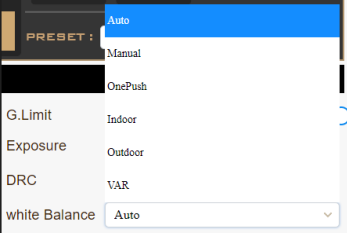
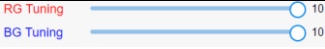

Image Setting

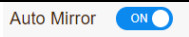
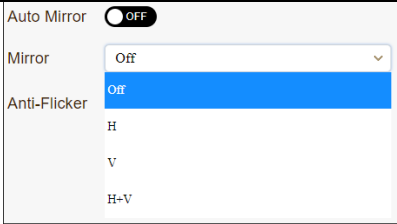
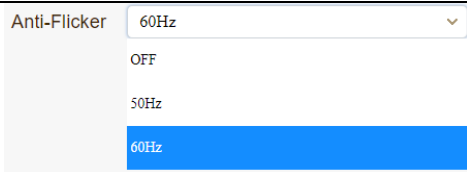
Please refer to the following table for "Image Settings" related functions.


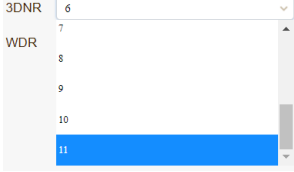

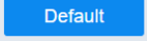
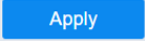
	Function Keys	Descriptions
1.	<p>Contrast </p>	<p>Contrast</p> <p>It allows the user to adjust the contrast. Use the slider to adjust the contrast, and press the "Apply" button to complete the setting.</p>

	Function Keys	Descriptions
2.		<p>Bright</p> <p>It allows the user to adjust the brightness. Please use the slider to adjust the brightness. After adjustment, press the "Apply" button to complete the setting.</p>
3		<p>Saturation</p> <p>It allows the user to adjust the saturation level. Use the slider to adjust the saturation, and press the "Apply" button after adjustment to complete the setting.</p>
4		<p>Hue</p> <p>It allows the user to adjust the color tone. Please use the slider to adjust the hue, and press the "Apply" button after adjustment to complete the setting.</p>
5		<p>Sharpness</p> <p>It allows the user to adjust the sharpness. Please use the slider to adjust the sharpness, after adjustment, press the "Apply" button to complete the setting.</p>
6		<p>G.Limit</p> <p>It allows the user to adjust the gain limit. Please use the slider to adjust the gain limit, after adjustment, press the "Apply" button to complete the setting.</p>


Function Keys		Descriptions
7		<p>Exposure</p> <p>The exposure drop-down menu allows the user to select the desired exposure mode. There are "Auto", "Manual", "Shutter Priority", "Aperture Priority" and "Brightness Priority" modes to choose from.</p> <ul style="list-style-type: none"> ● Auto: Fully automatic shutter speed and aperture settings with automatic adjustments for gain, dynamic range, backlight compensation, and anti-flicker. ● Manual: Manually control the aperture and shutter speed. ● SAE: The camera measures the light intensity and automatically adjusts the aperture according to the shutter speed you set. ● AAE: The camera measures the light intensity and adjusts the shutter speed according to the aperture size you set. ● Bright: The camera measures the

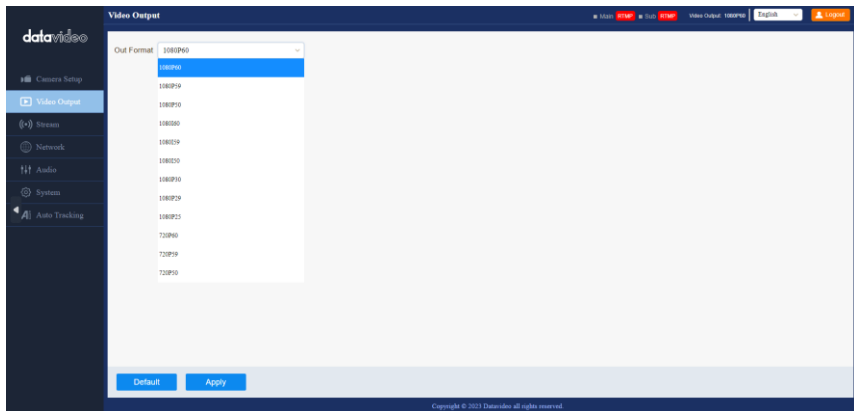
Function Keys		Descriptions
		<p>brightness and adjusts the appropriate exposure value.</p> <p>Press the "Apply" button to complete the setting.</p>
8		<p>Dynamic Range</p> <p>The Dynamic Range drop-down menu allows you to set the dynamic range or turn off the dynamic range function. Press the "Apply" button to complete the setting.</p>
9		<p>White Balance</p> <p>The white balance drop-down menu allows you to select the white balance mode you want. There are four white balance modes to choose from: Auto, Manual, One-Touch White Balance and Specified Color Temperature. Press the "Apply" button to complete the setting.</p>
10		<p>R Gain Adjustment/B Gain Adjustment</p> <p>Users can use the "R Gain Adjustment" slider and "B Gain Adjustment Slider" to adjust the Red Gain and Blue Gain. Press the "Apply" button to complete the setting.</p>
11		<p>Gamma</p> <p>This drop-down menu allows the user to adjust the Gamma value. This</p>

	Function Keys	Descriptions
		feature is currently not available.
12		<p>Auto Mirror</p> <p>The "Auto Mirror ON/OFF" switch allows the user to turn the auto mirror function on/off. When Auto Mirror is set to "ON", the screen will be displayed when a person is detected on the screen, regardless of whether the camera is in the upright position or hanging.</p>
13		<p>Mirroring</p> <p>When the "Auto Mirror ON/OFF" switch is set to "OFF", users can manually set the desired mirror style from the drop-down menu, with three options: "Horizontal Flip", "Vertical Flip" and "Horizontal and Vertical Flip". If you select "Off", the mirror function will be turned off. After adjustment, press the "Apply" button to complete the setting.</p>
14		<p>Anti-flicker</p> <p>To avoid image flicker, you can set the camera's flicker frequency to 50Hz or 60Hz, and if you select "Off", the anti-flicker</p>

	Function Keys	Descriptions
		function will be disabled. After adjustment, press the "Apply" button to complete the setting.
15		AGC Automatic Gain Control This is the AGC automatic gain control function. This function is not available yet.
16		3DNR This is a 3D Noise Reduction function that allows you to select the level of 3D Noise Reduction from a drop-down menu. After adjustment, press the "Apply" button to complete the setting.
17		WDR WDR is wide dynamic range. This feature is not yet available.
18		Default Pressing this button restores the relevant parameters in the Camera Settings option to the factory default settings.
19		Apply After you have set the relevant settings, click the "Apply" button to apply the selected settings.

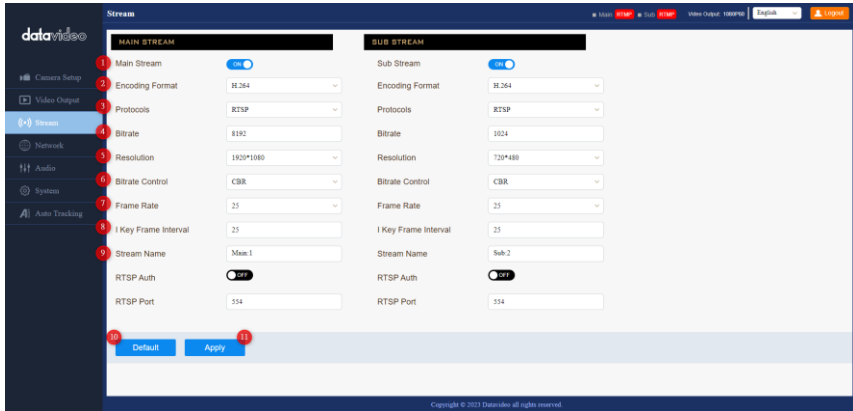
9.2 Video Output

The "Video Output" option  allows users to select the desired video output resolution from a drop-down menu. The image output interface is shown below. After selecting your desired video output resolution, press the "Apply" button to complete the setting. In the upper right corner of the "Video Output" interface, the output resolution you selected will be displayed. If you press the "Default" button, the default value can be restored.



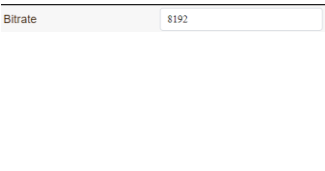


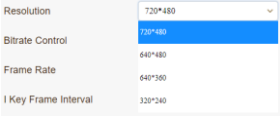
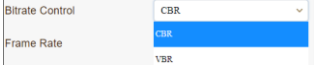
9.3 Stream

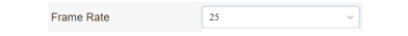

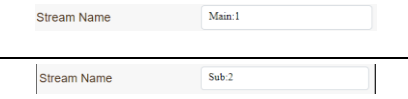
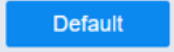
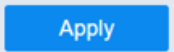

The "Stream" option allows you to set the main stream and sub-streams including "Stream ON/OFF" switch, "Encoding Format", "Protocols", "Bitrate", "Resolution", "Bitrate Control", "Frame Rate", "I Key Frame Interval", "Stream Name", "RTSP Authorization ON/OFF" switch, and "RTSP Port" and other related parameters. After setting, click "Apply" button to complete the setting. If you press the "Default" button, the options of "Streaming" interface can be restored to the factory default settings. "The main interface of the "Stream" option is shown below.



For "Streaming" related functions, please refer to the following table.

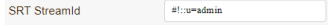
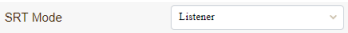
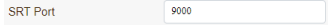
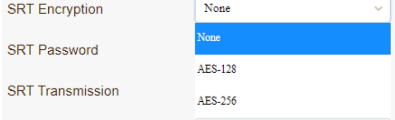
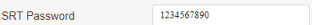

Function Keys		Descriptions
1.		<p>Streaming ON/OFF Switch</p> <p>You can press this ON/OFF switch to turn on or off the streaming function of "Main Stream" or "Sub Stream".</p>
2		<p>Encoding Format</p> <p>This option allows you to select the encoding format for streaming video. There are 3 encoding formats to choose from: "H.264", "H.265" and "MJPEG".</p>
3		<p>Protocols: Multicast, RTSP, RTMP(S), SRT and ONVIF</p> <p>There are five streaming protocols to choose from: Multicast, RTSP, RTMP(S), SRT and ONVIF.</p>

	Function Keys	Descriptions
4	 	<p>Bit Rate</p> <p>The bit rate is the amount of data required to encode an image in one second. From the streaming point of view, the higher the bit rate, the higher the quality, but it also requires more bandwidth. The default bit rate for the main stream is "8192 Kb/s". The default bit rate for sub-streams is "1024 Kb/s".</p>
5	 	<p>Resolution</p> <p>The following resolutions are supported for the main stream and sub-streams respectively.</p> <p>Main Stream</p> <ul style="list-style-type: none"> 1920 x 1080 1080 x 720 <p>Sub Stream</p> <ul style="list-style-type: none"> 720 x 480 640 x 480 640 x 360 320 x 240
6		<p>Bit Rate Control</p> <p>You can select either a fixed bit rate or a variable bit rate. Fixed bit rate encoding does not optimize image quality, but it saves your storage space. Variable bit rate encoding takes longer but produces more satisfactory results because it optimizes the quality of your media files.</p>

	Function Keys	Descriptions
7		<p>Frame rate</p> <p>A high frame rate for a smoother viewing experience, the default frame rate is 25.</p>
8		<p>I Frame Interval</p> <p>The shorter the I Frame interval, the higher the image quality. However, a larger bandwidth is required. Selecting a longer I Frame interval requires less bandwidth but results in a lower quality image. The default I Frame interval is 25.</p>
9		<p>Stream Name</p> <p>This option allows you to set the stream name of the main stream or sub-stream.</p>
10		<p>Default</p> <p>Pressing this button restores the relevant parameters in the Streaming option to their factory default settings.</p>
11		<p>Apply</p> <p>After you have set the relevant settings, click the "Apply" button to apply the selected settings.</p>
12		<p>Streaming Status Alert Icon</p> <p>This icon shows the current streaming status of the master stream and sub-streams. If the main stream or sub-streams are streaming, the icon will be white on red. If it is not streaming, the icon will be grayed out.</p>

Function Keys	Descriptions
RTSP streaming	
<div style="border: 1px solid #ccc; padding: 5px; display: flex; align-items: center;"> RTSP Auth <div style="border: 1px solid #ccc; border-radius: 10px; padding: 2px 10px; display: flex; align-items: center;"> <input type="checkbox"/> OFF </div> </div>	<p>RTSP Authorization</p> <p>If the "RTSP Authorization" option is set to "ON", when you want to stream RTSP, you need to enter your PTC-145 Web UI login password, which is defaulted to "admin", in the RTSP streaming video player to view your RTSP streaming video.</p>
<div style="border: 1px solid #ccc; padding: 5px; display: flex; align-items: center;"> RTSP Port <div style="border: 1px solid #ccc; padding: 2px 10px; width: 150px; text-align: center;">554</div> </div>	<p>RTSP Port</p> <p>This is the RTSP port number, which is 554 by default.</p>
RTMPS streaming	
<div style="border: 1px solid #ccc; padding: 5px; display: flex; align-items: center;"> MRL <div style="border: 1px solid #ccc; padding: 2px 10px; flex-grow: 1;">rtmp://192.168.5.11/live/av0</div> </div>	<p>MRL</p> <p>When you choose RTMPS streaming, you need to fill in the MRL field with the streaming server address and streaming key in the format of "Streaming Server URL / Streaming Key" obtained from RTMPS streaming platforms such as Youtube, Facebook, and so on. In the case of the Facebook platform, the MRL is: rtmps://live-api-s.facebook.com:443/rtmp/FB-10211107991653400-0-Abzq_4uxzlu2C7k3</p>
SRT Streaming (SRT Caller Mode)	

Function Keys	Descriptions
<p>SRT Mode <input type="text" value="Caller"/></p>	<p>SRT Mode When SRT streaming is selected, you can choose either "Caller" or "Listener" mode from this drop-down menu. This is the SRT Caller mode.</p>
<p>SRT 伺服器地址 <input type="text" value="192.168.100.1"/></p>	<p>SRT Server Address If your PTC-145 is set to SRT Caller mode, you need to fill in the "SRT Server Address" field with the SRT server address you obtained from your SRT streaming platform.</p>
<p>SRT Address <input type="text" value="192.168.5.50"/></p>	<p>SRT Port If your PTC-145 is set to SRT Caller mode, you need to fill in the "SRT Port" field with the SRT port number you obtained from your SRT streaming platform. SRT port number you obtained from your SRT streaming platform into this "SRT Port" field.</p>
<p>SRT Encryption <input type="text" value="None"/> SRT Password <input type="text" value="None"/> SRT Transmission <input type="text" value="AES-128"/></p>	<p>SRT Encryption Method When you select the SRT streaming protocol, this option allows you to choose the SRT encryption method you want to use, with three options including None, AES128 and AES-256.</p>
<p>SRT Password <input type="text" value="1234567890"/></p>	<p>SRT Password After setting SRT encryption method, you need to use this SRT password, the default value is 1234567890, which can be changed by user.</p>
<p>SRT Transmission <input type="text" value="120"/></p>	<p>SRT Transmission This field allows you to set</p>

Function Keys	Descriptions
	the transmission delay time for SRT streams. The setting range is 20-8000.
	SRT Stream ID This is where you fill in the SRT Stream ID, which is usually provided by your CDN or cloud service platform.
SRT streaming (SRT Listener mode)	
	SRT Mode When SRT streaming is selected, you can choose either "Caller" or "Listener" mode from this drop-down menu. This is the SRT Listener mode.
	SRT Port This is the SRT port and the default value is 9000.
	SRT Encryption Method When you select the SRT streaming protocol, this option allows you to choose the SRT encryption method you want to use, with three options including None, AES128 and AES-256.
	SRT Password After setting SRT encryption method, you need to use this SRT password, the default value is 1234567890, which can be changed by user.
	SRT Transmission This field allows you to set the transmission delay time for SRT streams. The setting range is 20-8000.
MultiCast	

Function Keys	Descriptions
<p>Address <input data-bbox="389 124 572 151" type="text" value="224.1.2.3"/></p>	<p>Address This address is the location of the multicast, the default value is 224.1.2.3</p>
<p>Port <input data-bbox="389 258 572 285" type="text" value="4000"/></p>	<p>Port This is the port number for the multicast function and the default value is 4000.</p>
<p>ONVIF</p>	
<p>ONVIF authorization <input data-bbox="497 501 561 528" type="checkbox" value="OFF"/></p>	<p>ONVIF Authorization This is the ON/OFF switch for ONVIF authorization.</p>

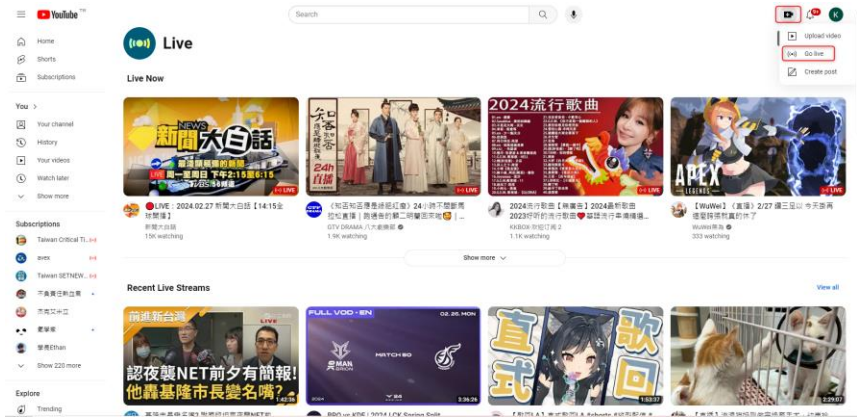
Notes.

1. SRT Caller and RTSP Publish can only work on the "Main Stream".
2. When SRT Caller and RTSP Publish are working on the "Main Stream", the "Sub Streams" will have no function.

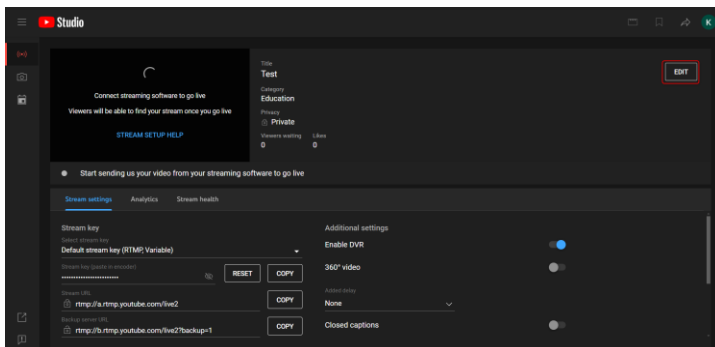
Streaming to Youtube

Please see the following steps to learn how to stream to Youtube.

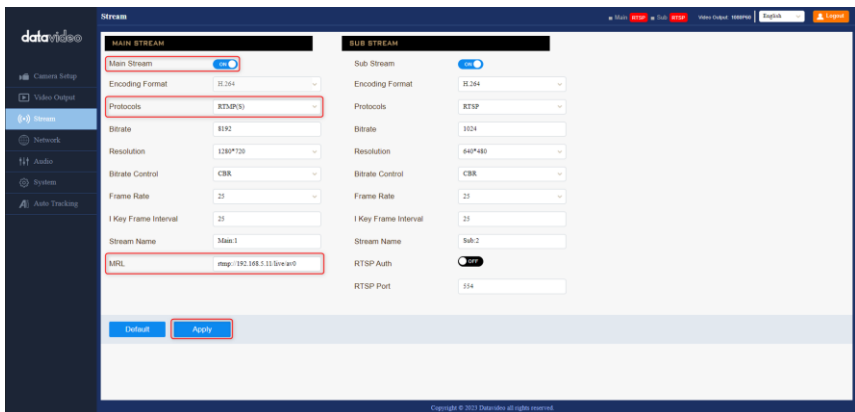
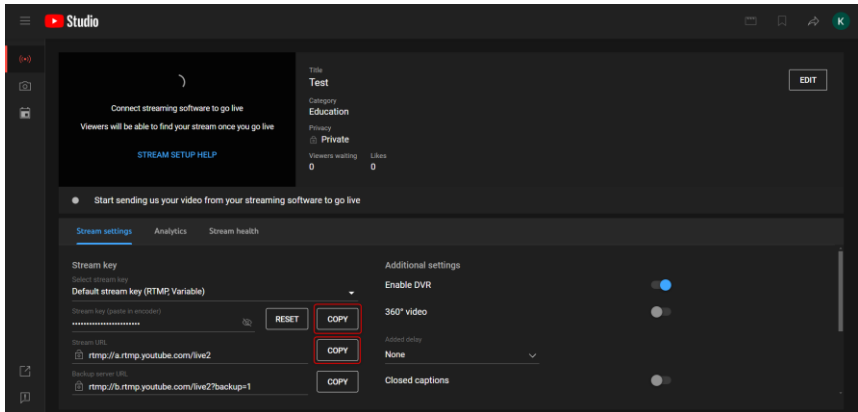
1. Please connect to the Youtube website www.youtube.com and click the "Create" button, and then click "Go Live".



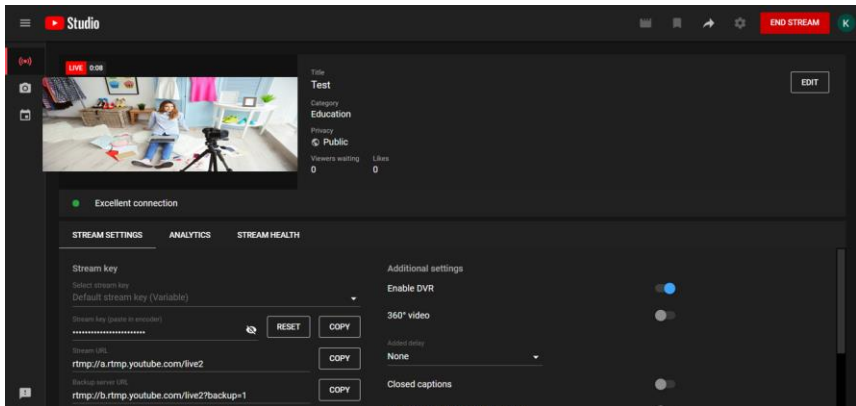
2. You will see the main page of "Youtube Studio". Please click the "Edit" button to set the details of your live event, and click the "Save" button when you are done.



3. You will see the streaming key and streaming URL provided by Youtube streaming platform. Take the main stream as an example, please set the "Stream" > "Main Streaming ON/OFF" switch of PTC-145 Web UI to "ON" and select "RTMP(S)" in the "Protocol" drop-down menu, then please copy the "Stream URL" and "Stream Key" separately and paste them into the "Stream>MRL" of the PTC-145 Web UI according to the format of "Stream URL/Stream Key". Finally, click the "Apply" button.



4. Please restart the PTC-145 camera and you will see the start screen on the Youtube live stream page. Click the "END STREAM" button to end the live stream.

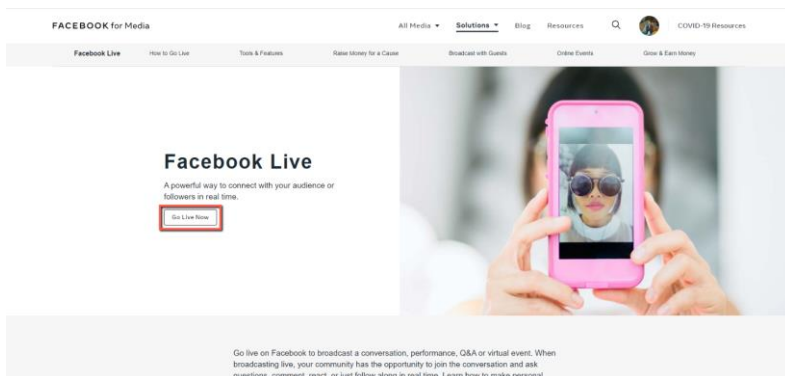


Streaming to Facebook

Below are the steps to set up a live streaming on Facebook Live Producer using RTMP:

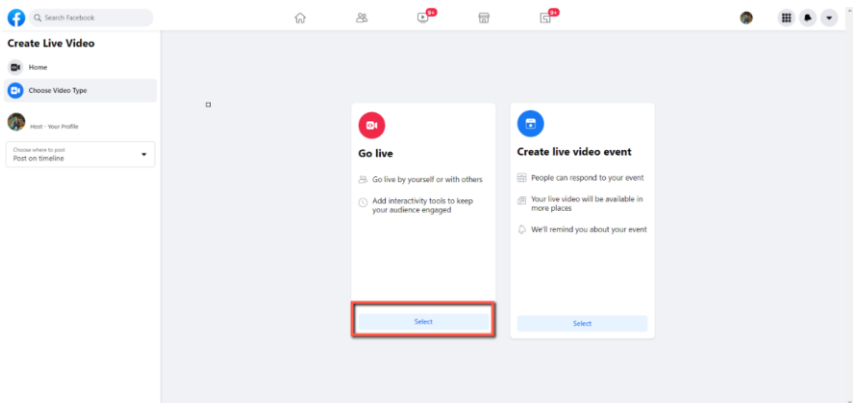
Live Streaming with Facebook Live Producer

1. Open the Facebook Live website.
<https://www.facebook.com/formedia/solutions/facebook-live> and click the "Go Live Now" button as shown below.

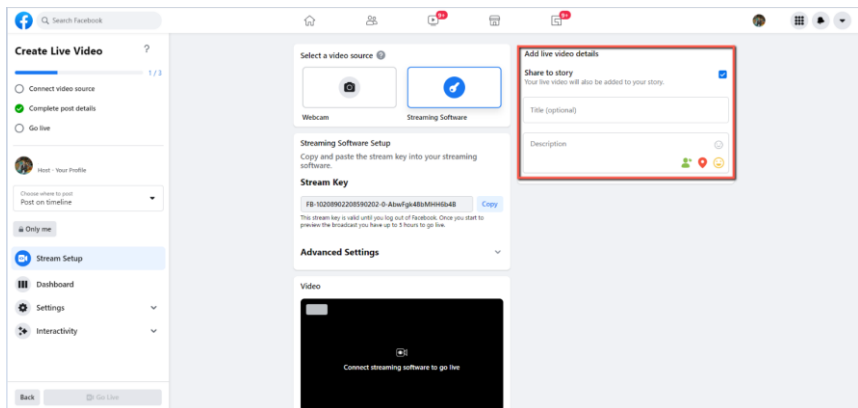


Note: A single live stream on Facebook platform cannot exceed 8 hours.

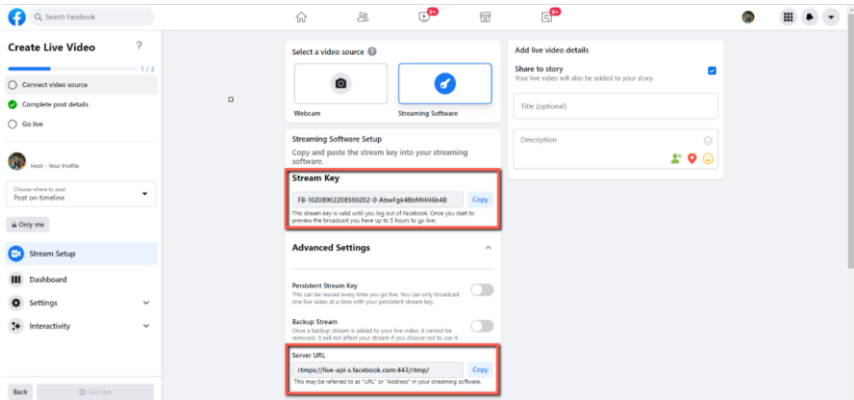
2. Please click the "Select" button on the "Go Live" option as shown below.



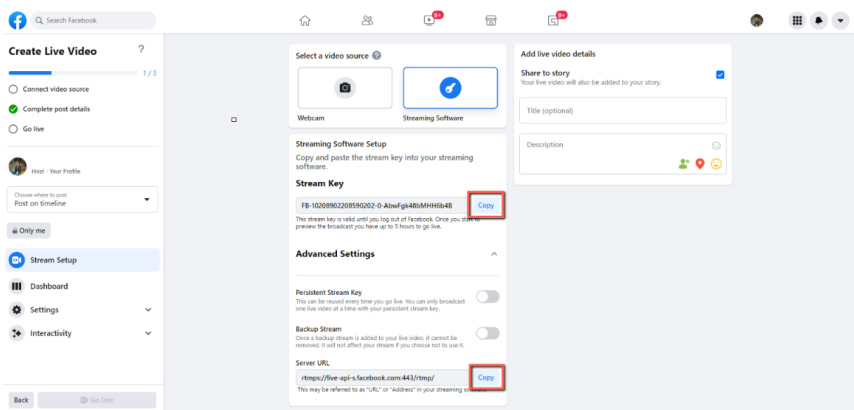
3. Select the "Streaming Software" option and enter the title and description of your live video in the "Title" and "Description" fields. You can also choose whether or not to share the live stream to your Facebook story.

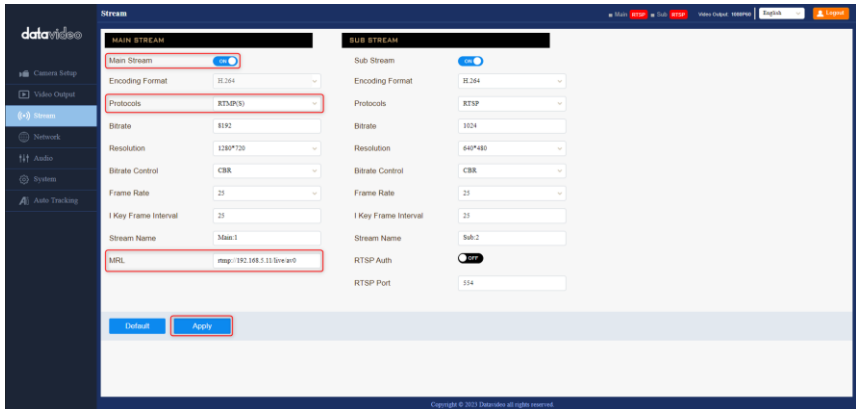


4. Please click "Advanced Settings" and you will be able to see the "Server URL" required for live streaming, to match with the "Stream Key" on the page for live streaming.

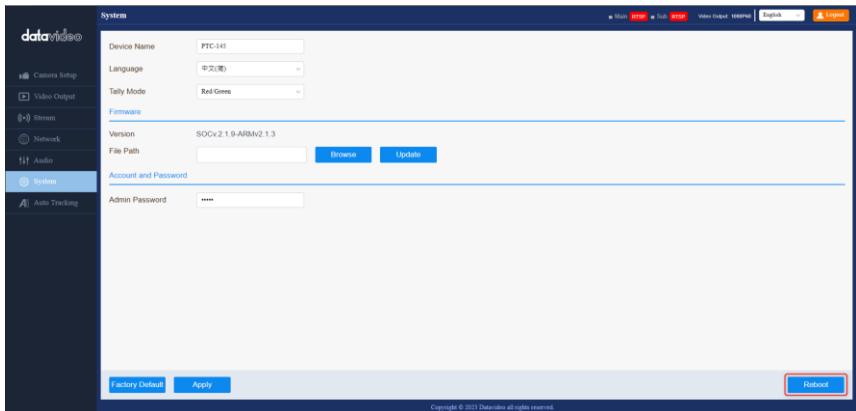


5. Take the main stream as an example, please set the "Streaming" > "Main Streaming ON/OFF" switch of the PTC-145 Web UI to "ON" and select "RTMP(S)" from the "Protocol" drop-down menu, then please copy the "Server URL" and "Stream Key" separately and paste them into the "Streaming > MRL" field of the PTC-145 Web UI according to the format of "Stream URL/Stream Key". Finally, click the "Apply" button.

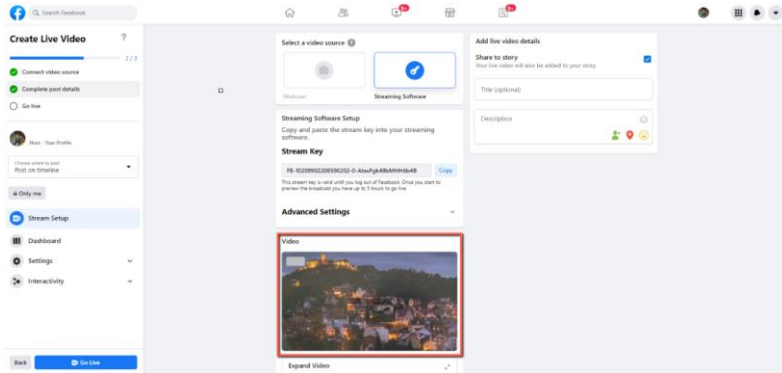




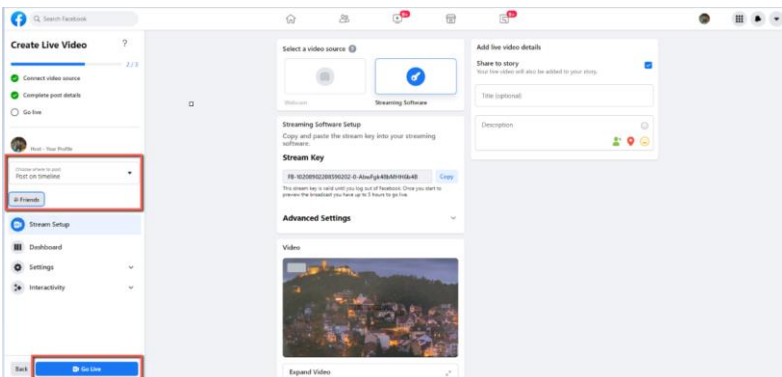
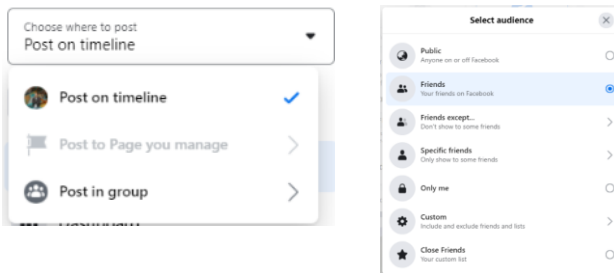
6. Please go to the "System" option and click the "Reboot" button to reboot the PTC-145.



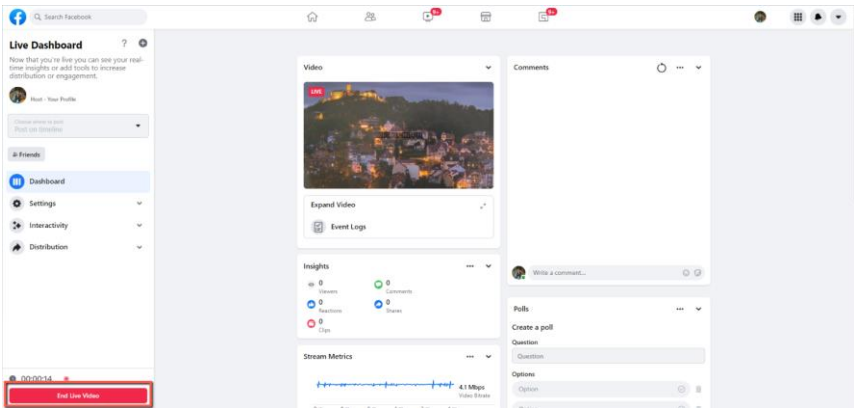
7. After the reboot is complete, you can see a preview of the live screen captured by the PTC-145 camera in the "Video" option on the Facebook Live page.



8. Please set the relevant settings, including "Choose where to post" and "Select audience", and then click the "Start Live Streaming" button to live stream the footage captured by the PTC-145 immediately.

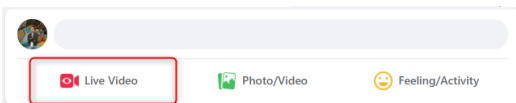


9. You will see the screen of the live stream that has been successfully carried out. If you want to end the live stream, please click the "End Live Video" button to end the live stream immediately.

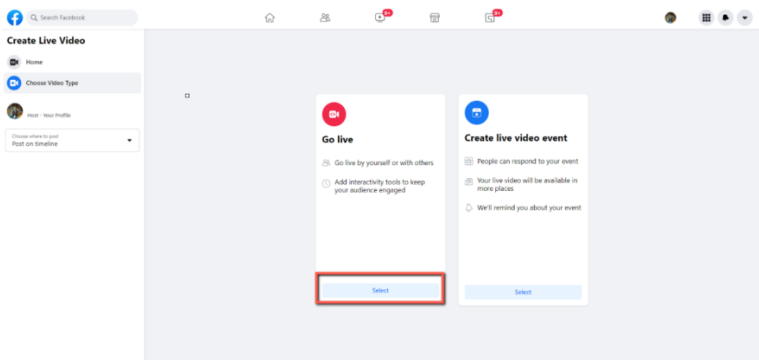


Live streaming using your personal Facebook page or fan page

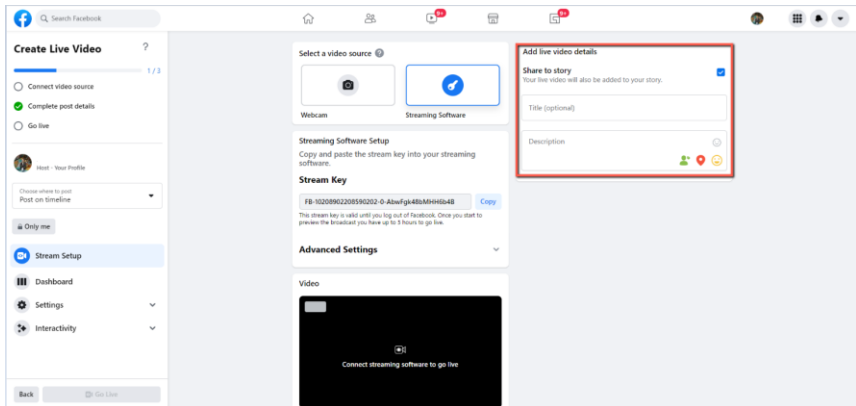
1. Please click the "Live Video" button from your Facebook page or fan page.



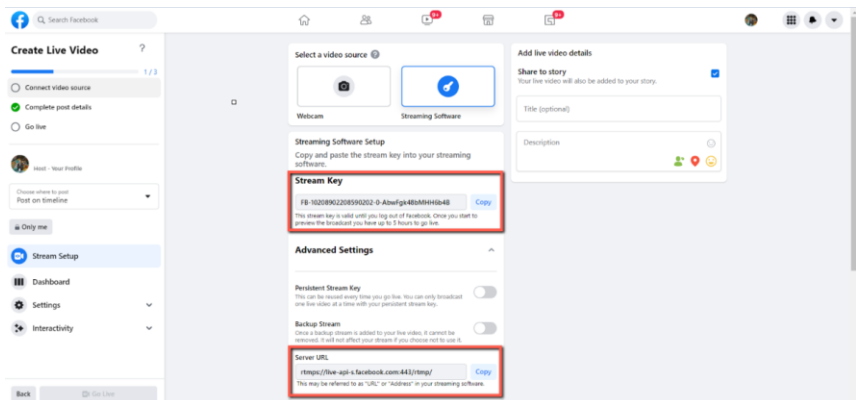
2. Please click the "Go Live" button from the "Go live" option which is shown in the following diagram.



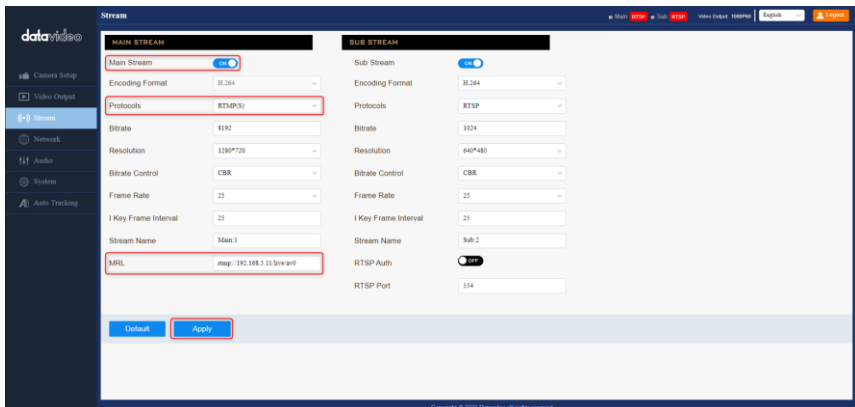
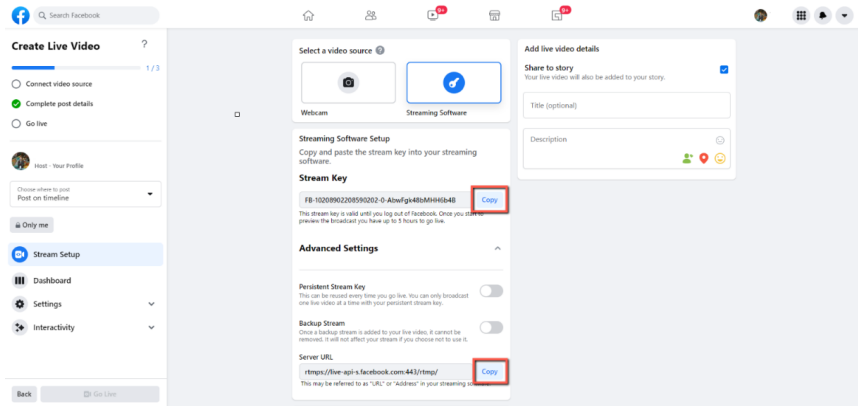
3. Select the "Streaming Software" option and enter the title and description of your live video in the "Title" and "Description" fields. You can also choose whether or not to share the live stream to your Facebook story.



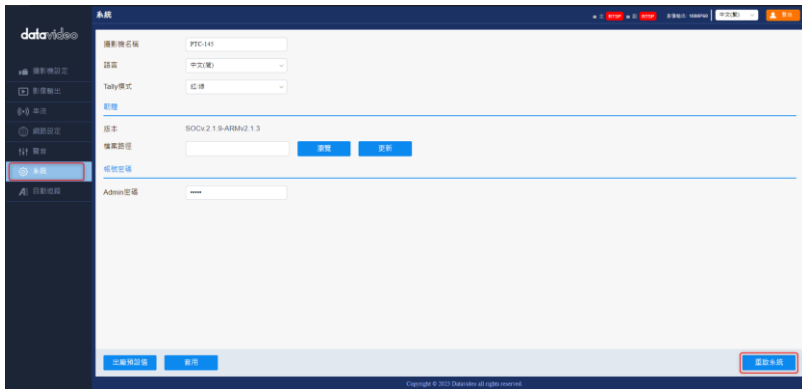
4. Please click "Advanced Settings" and you will be able to see the "Server URL" required for live streaming, to match with the "Stream Key" on the page for live streaming.



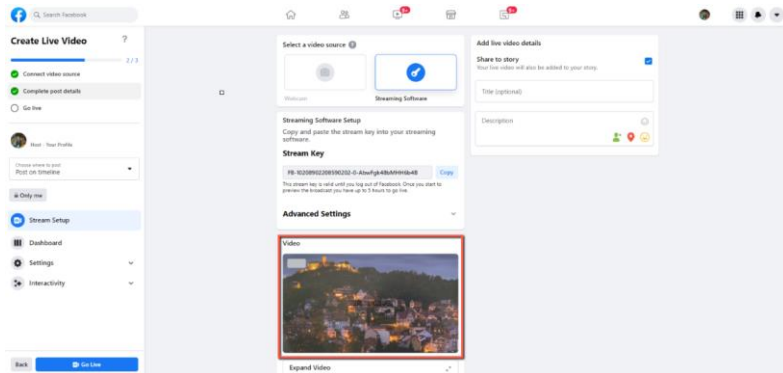
5. Take the main stream as an example, please set the "Streaming" > "Main Streaming ON/OFF" switch of the PTC-145 Web UI to "ON" and select "RTMP(S)" from the "Protocol" drop-down menu, then please copy the "Server URL" and "Stream Key" separately and paste them into the "Streaming > MRL" field of the PTC-145 Web UI according to the format of "Stream URL/Stream Key". Finally, click the "Apply" button.



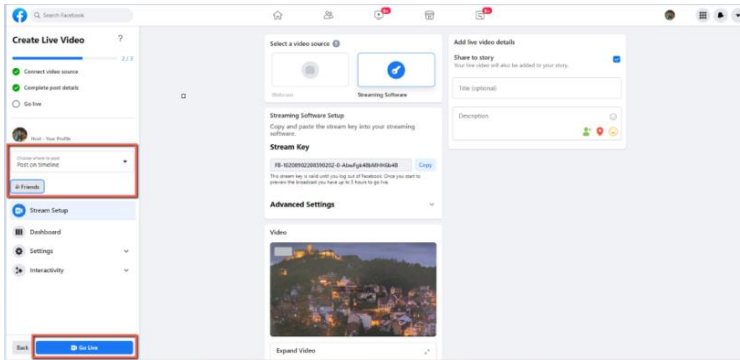
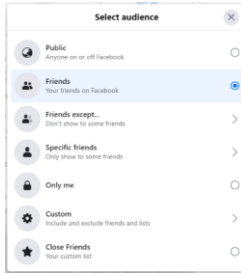
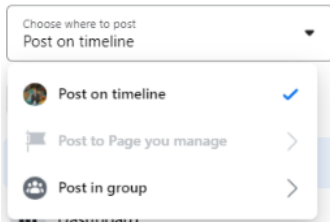
6. Please go to the "System" option and click the "Reboot" button to reboot the PTC-145.



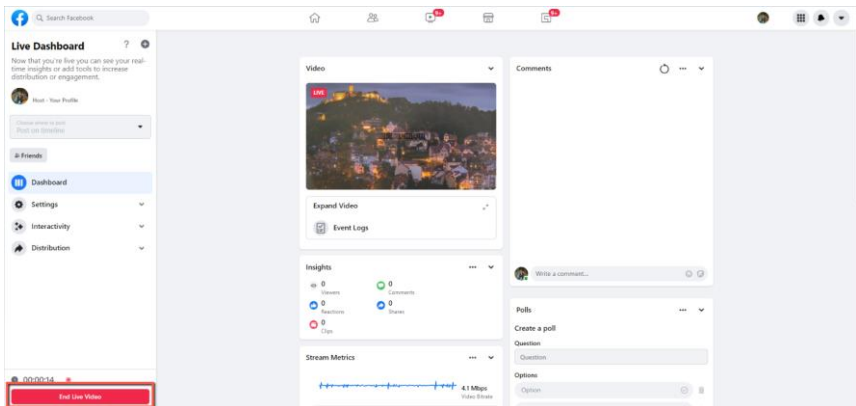
7. After the reboot is complete, you can see a preview of the live screen captured by the PTC-145 camera in the "Video" option on the Facebook Live page.



8. Please set the relevant settings, including "Choose where to post" and "Select audience", and then click the "Start Live Streaming" button to live stream the footage captured by the PTC-145 immediately.



9. You will see the screen of the live stream that has been successfully carried out. If you want to end the live stream, please click the "End Live Video" button to end the live stream immediately.




How to do the SRT Streaming by the vMix Software

How to install the Vmix Software

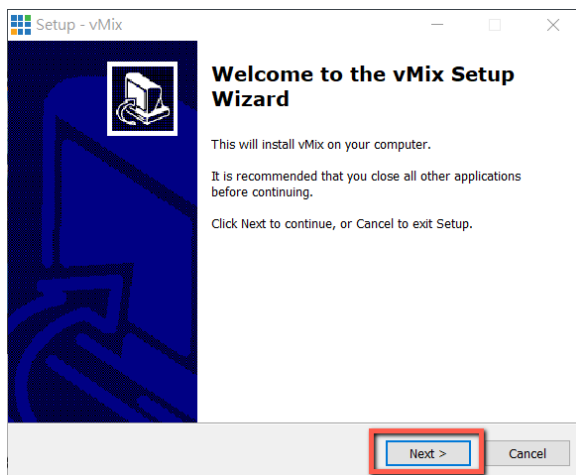
Please install the vMix software according to following steps.

1. At first, please go to vMix official website and then download the vMix 60-day free-trial. This section will use vMix free-trial as an example to demonstrate the operation steps. Please click the “DOWNLOAD FREE TRIAL” button for downloading.

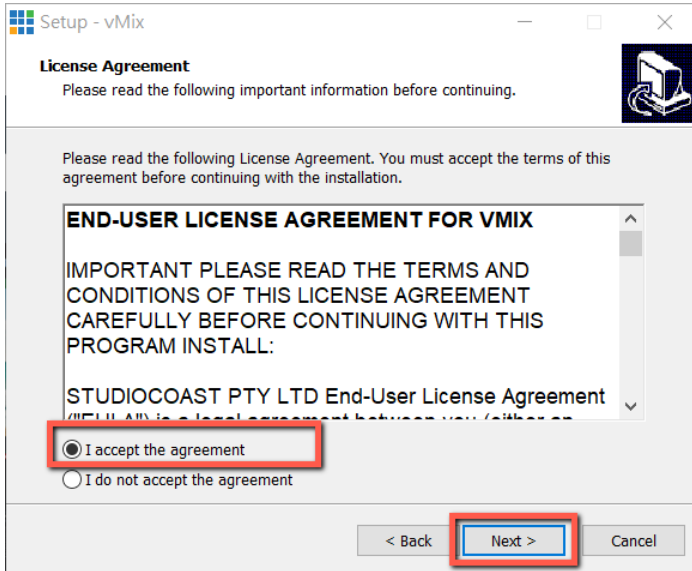


2. Please double-click the vmix23.exe  vmix23 .

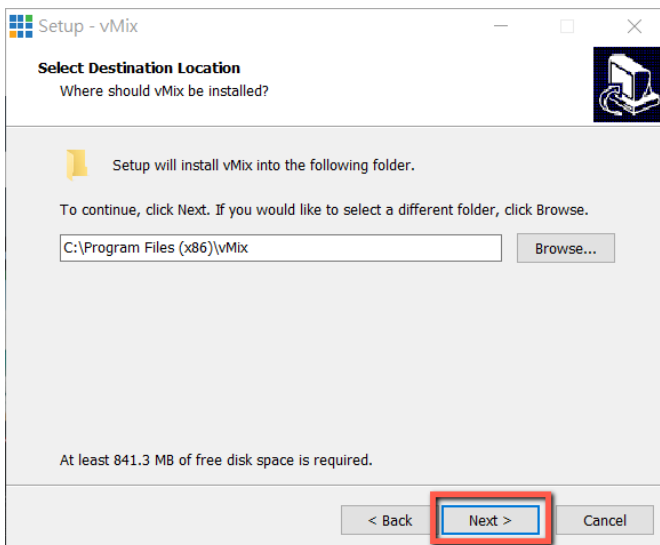
3. Please click the “Next” button.



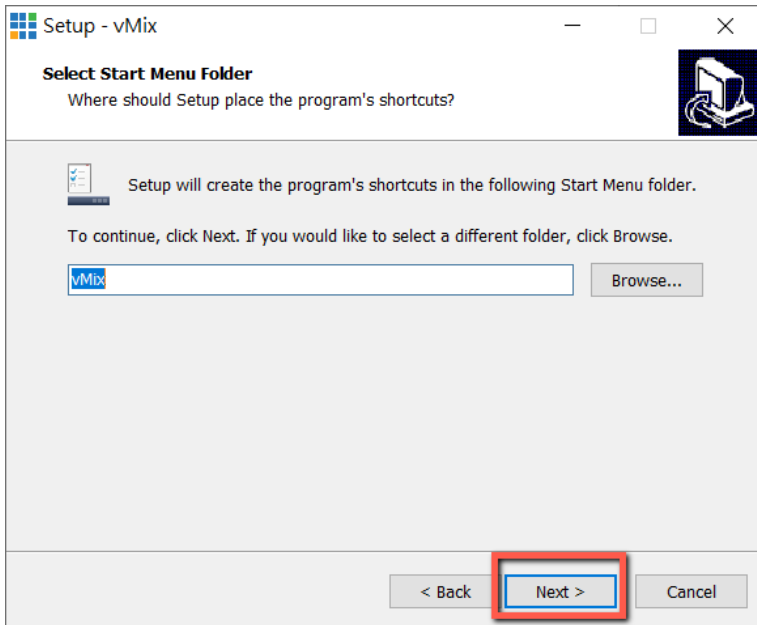
4. Please click “I accept the agreement” and then click the “Next” button.



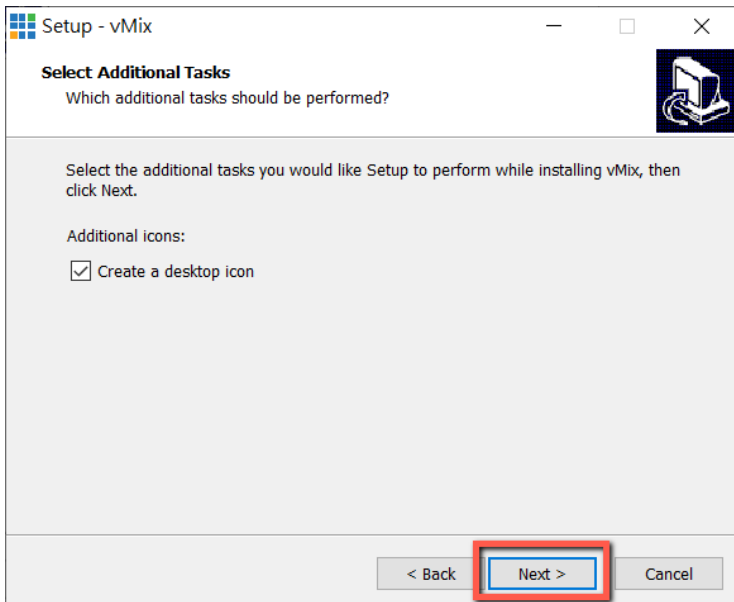
5. Please click the “Next” button.



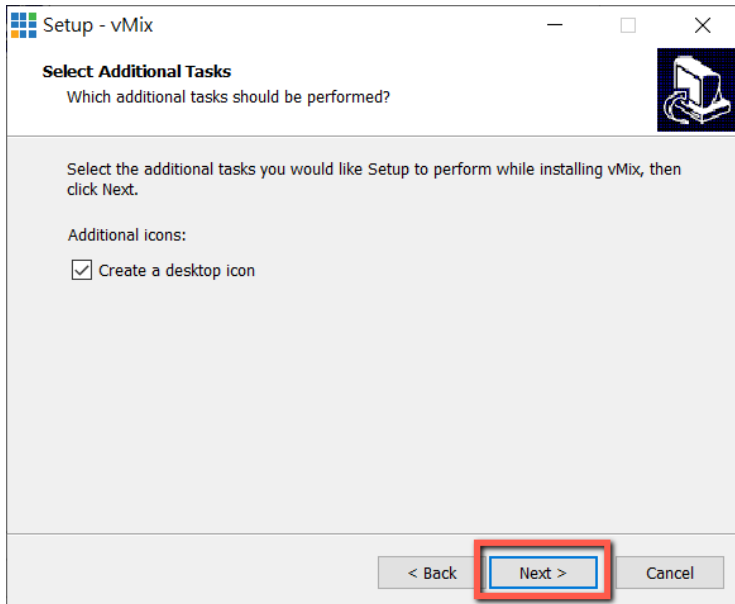
6. Please click the “Next” button.



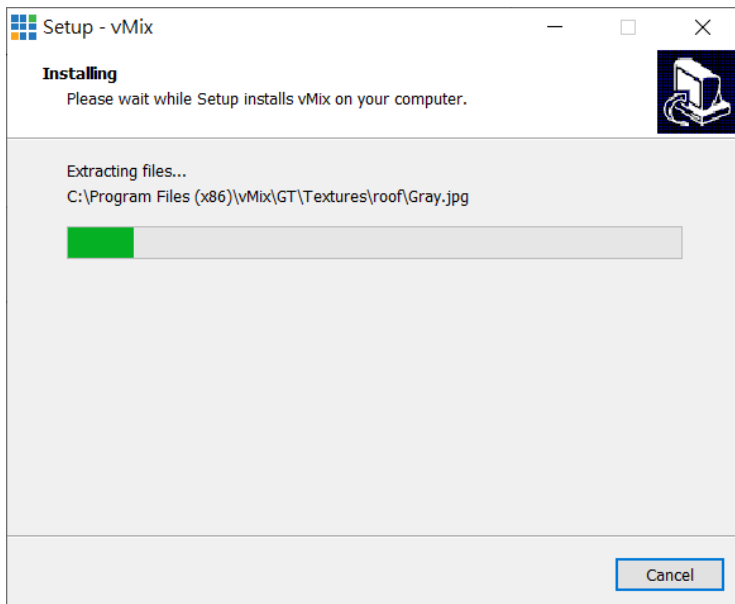
7. Please click the “Next” button.



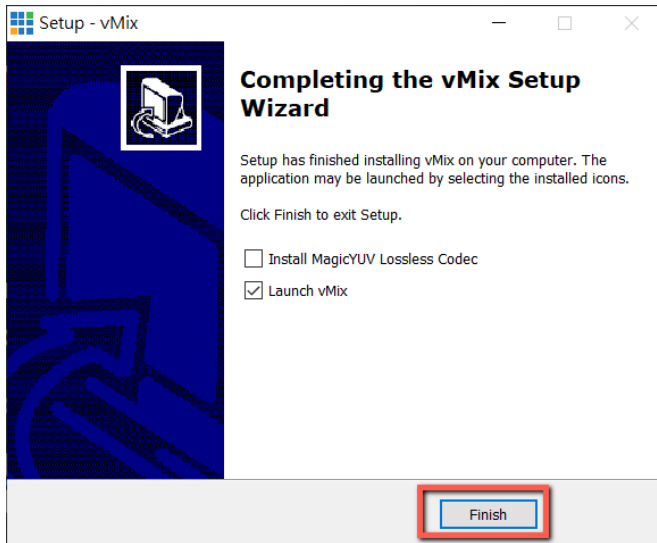
8. Please click the “Install” button.



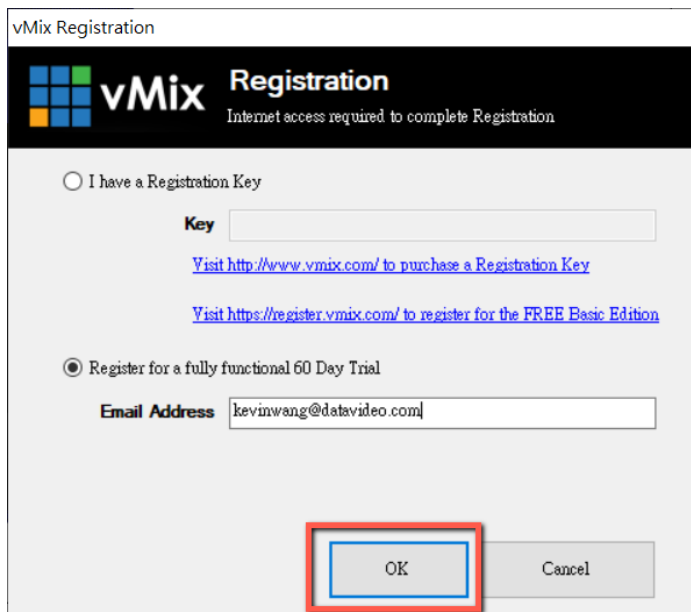
9. The installation will be started.



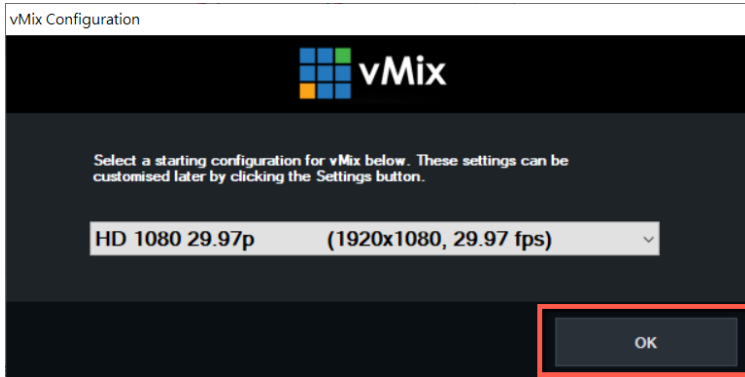
10. Please click the “Finish” button to finish the installation.



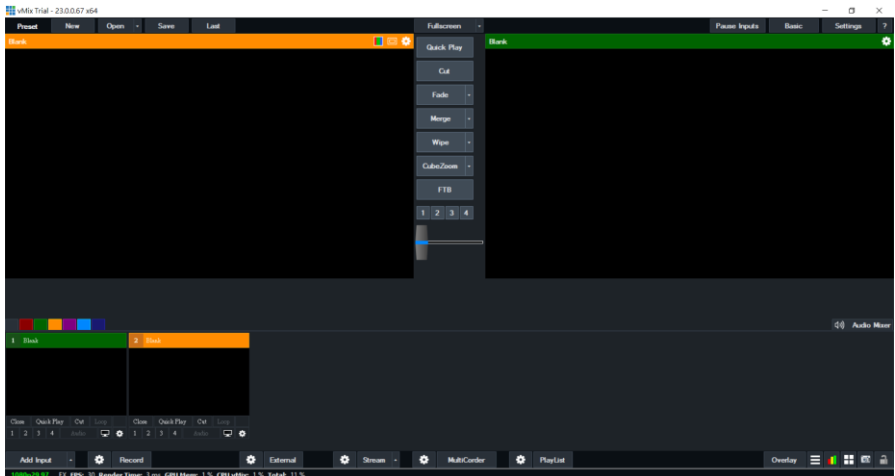
11. Please select “Register for a fully functional 60 Day Trial” to fill out your Email Address. After that, please click the “OK” button to open the vMix software.



12. Please select the initial resolution and frame rate that you want to use and then please click the “OK” button.



13. After opening vMix, the software interface is shown as following diagram.



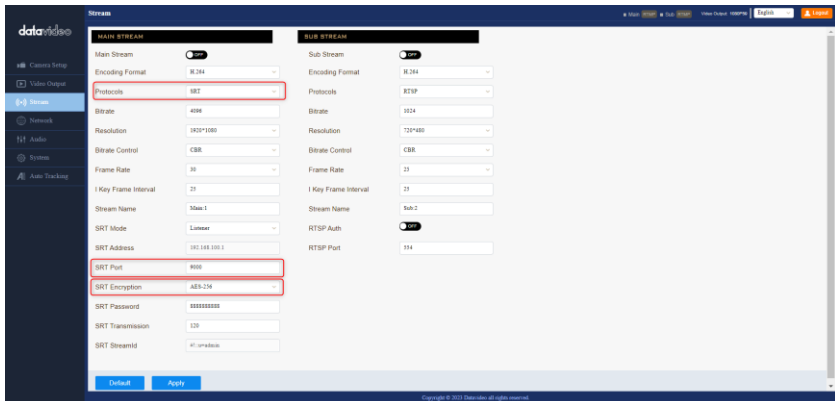
SRT Streaming with PTC-145 Camera and vMix Software

SRT streaming is divided into Caller Mode and Listener Mode, the following steps will help you understand how to operate.

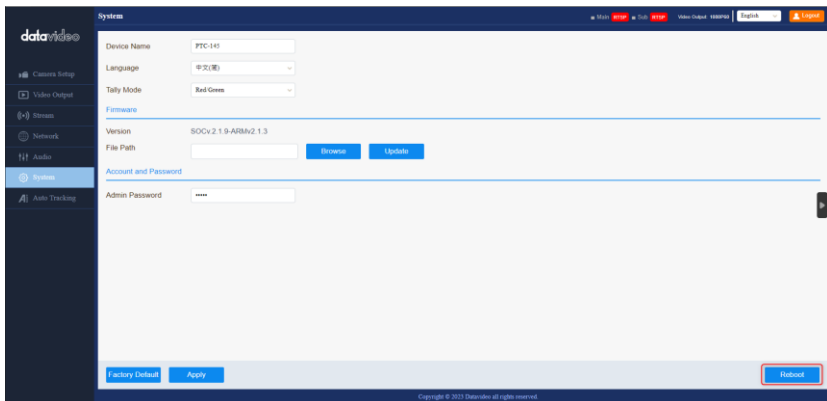
Note: If vMix is set to Caller mode, then PTC-145 should be set to Listener mode. If vMix is set to Listener mode, the PTC-145 needs to be set to Caller mode.

Setting PTC-145 to Listener Mode

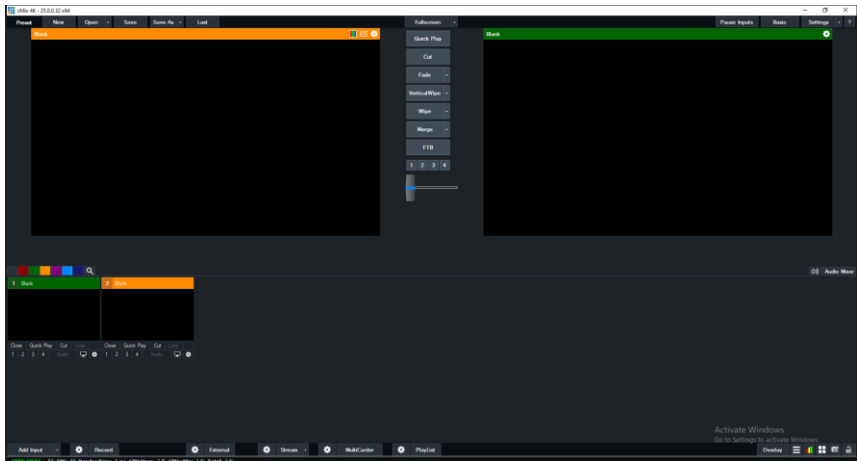
Open the PTC-145 Web UI interface, click the "Stream" option → select the "SRT" option from the "Protocols" drop-down menu. The "SRT Port" option is set to 9000 by default, and the "SRT Password" and "SRT Encryption" in this example are set to 888888888888 and AES-256 respectively. Click the "Apply" button when you are done with the setup.



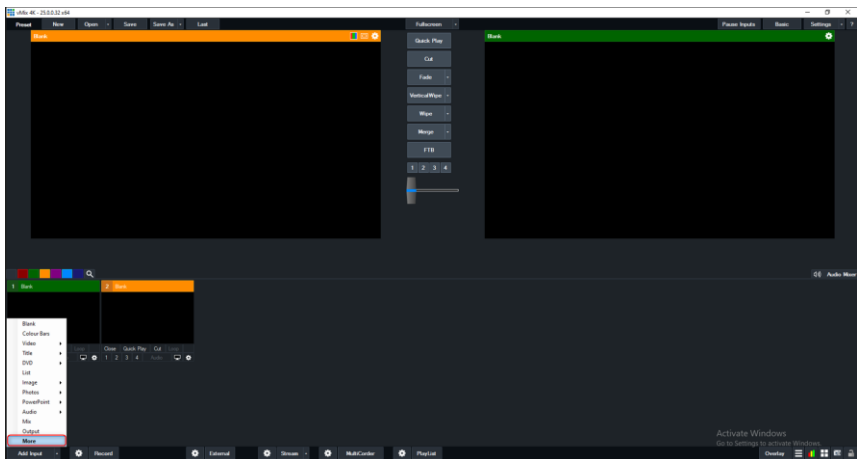
Please click "System" > "Reboot" button to reboot the PTC-145 to make the new settings take effect.



On your computer, after opening the Start Menu, click vMix(x64) to open the Vmix software and you will see the vMix main interface as shown below.



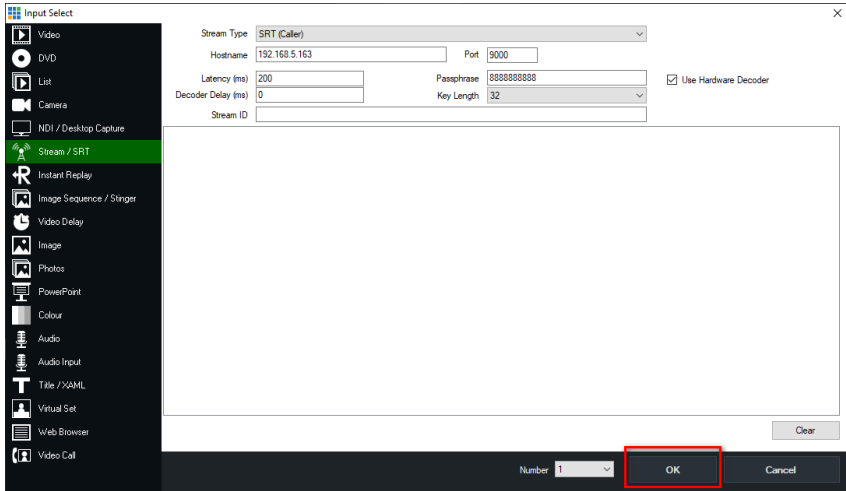
Click "Add Input" and select "More" from the pull-up menu.



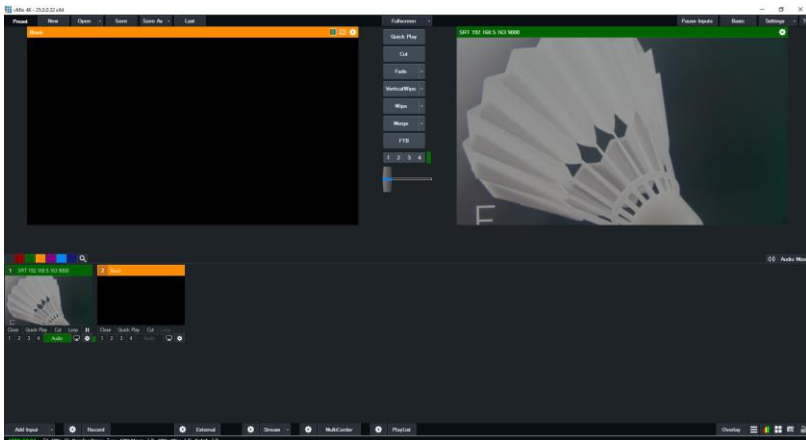
Click the “Stream/SRT” option in the “Input Select” interface that opens, select SRT Caller in the Stream Type drop-down menu, and then enter the following field information:

- Enter the IP address of the connected device in the "Hostname" field, for example, 192.168.5.163 for PTC-145.

- The "Port" field is entered by the SRT port number 9000 in "Streaming->SRT Port" in the PTC-145 web UI.
- Enter the password 8888888888 set by the PTC-145 Web UI in the "Passphrase" field.
- The "Key Length" drop-down menu can be unselected.
- Finally, click the "OK" button.



The images captured by the PTC-145 should be successfully streamed to the vMix software in SRT Listener mode.



Setting the PTC-145 to Caller Mode

Go to the PTC-145 Web UI interface, click the "Stream" option, and then enter the information in the following fields:

- Click on the "Protocols" drop-down menu and select SRT.
- The "SRT Address" field enters the IP address of the device on which the Vmix software is installed. In this example, it is a laptop computer and its IP address is 192.168.5.50.
- The "SRT Port" is the default value of 9000 for PTC-145.
- The SRT password is entered into the "SRT Password" field, in this case 888888888888.

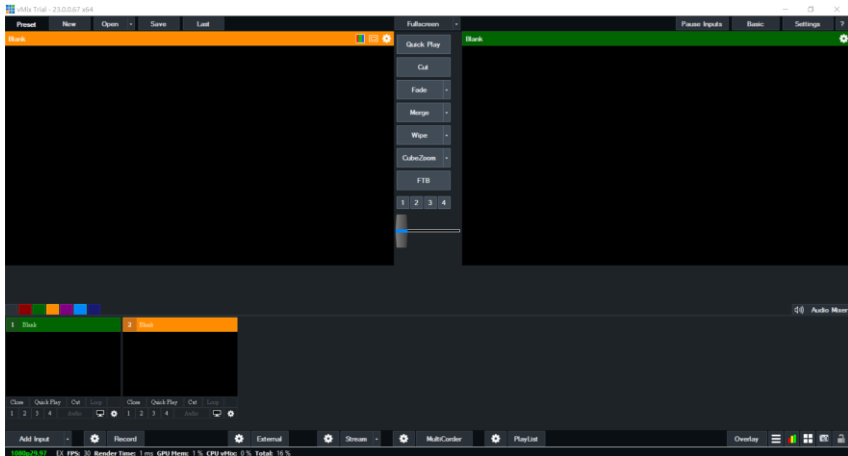
Click the "Apply" button to save the SRT Caller settings.

MAIN STREAM	SUB STREAM
Main Stream: ON	Sub Stream: OFF
Encoding Format: H.264	Encoding Format: H.264
Protocols: SRT	Protocols: RTSP
Bitrate: 4096	Bitrate: 1024
Resolution: 1024*1024	Resolution: 720*480
Bitrate Control: CBR	Bitrate Control: CBR
Frame Rate: 30	Frame Rate: 25
I Key Frame Interval: 25	I Key Frame Interval: 25
Stream Name: Main 1	Stream Name: Sub 2
SRT Mode: Caller	RTSP Auth: SRT
SRT Address: 192.168.5.50	RTSP Port: 344
SRT Port: 9000	
SRT Encryption: AES-256	
SRT Password: 88888888	
SRT Transmission: 120	
SRT Streamid: #1-urldata	

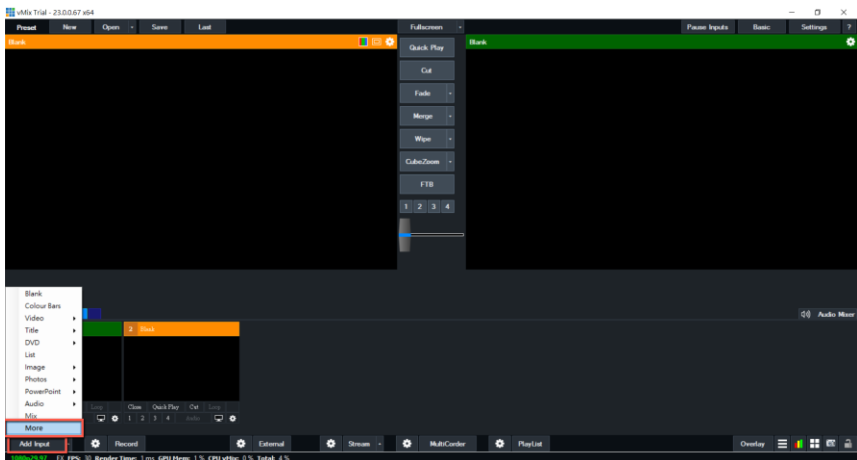
Click the "Reboot" button in the "System" option to reboot the PTC-145.

Device Name	PTC-145
Language	中文
Tally Mode	Red Green
Firmware	
Version	SOCv2.1.0-ARMv2.1.3
File Path	
Account and Password	
Admin Password	****

On your computer, after opening the Start Menu, click vMix(x64) to open the Vmix software and you will see the vMix main interface as shown below.



Click "Add Input" and select "More" from the pull-up menu.

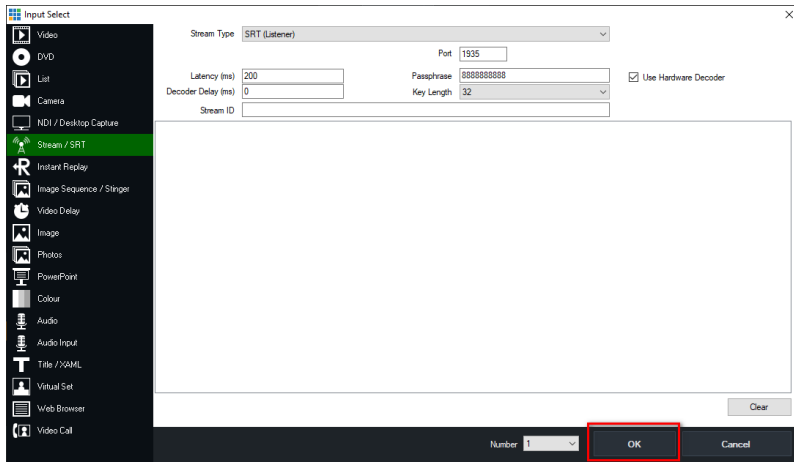


Click the "Stream/SRT" option in the open Input Selection interface, select SRT Listener in the Stream Type drop-down menu, and then enter the following field information:

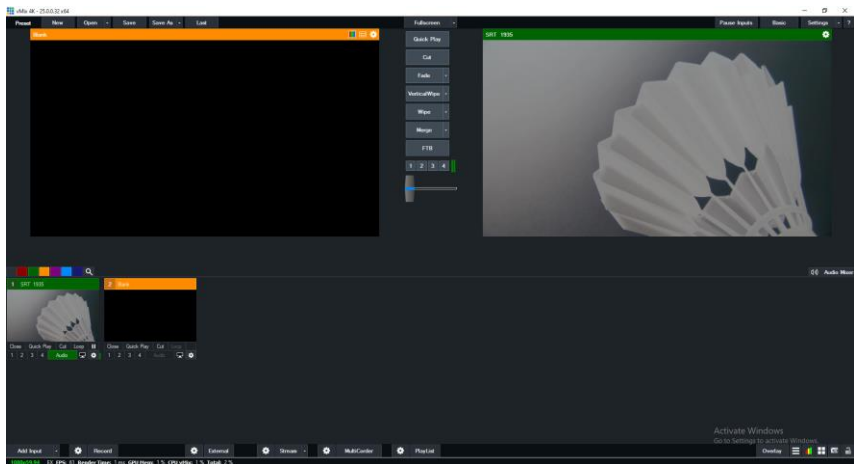
- Enter 1935 into the "Port" field (the "Host Port" value of the PTC-145 Web UI).
- Enter 8888888888 in the "Passphrase" field to match the SRT password set in the PTC-145 Web UI.

- The "Key Length" drop-down menu selects a key length of 32, which is consistent with the "SRT Key Length" setting in the PTC-145 Web UI.

Finally, press the "OK" button.

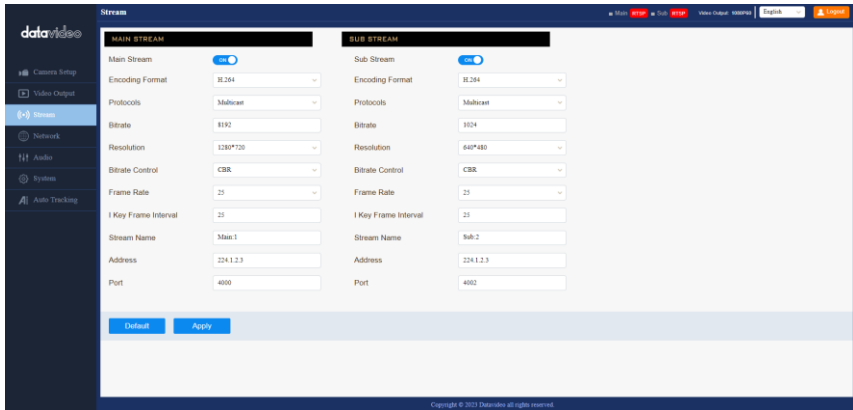


The images captured by the PTC-145 should be successfully streamed to the vMix software in SRT Caller mode.



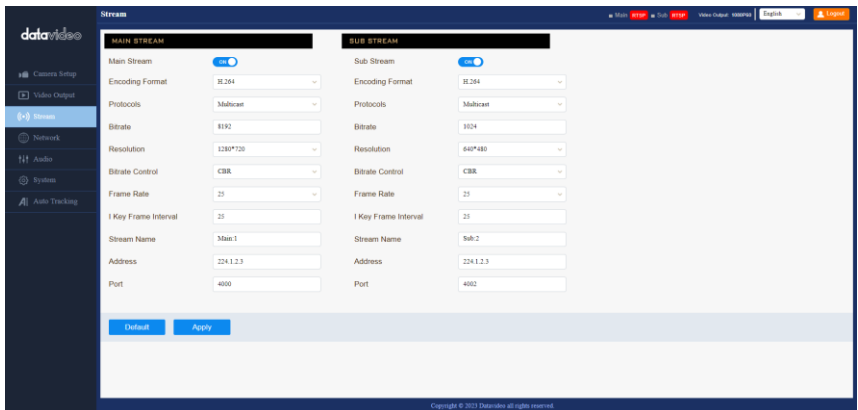
Multicast

Multicast allows you to view camcorder images remotely through a specific video player, such as VLC media player.



You can stream camera images via Multicast (multicast setting). Perform the following steps to stream TS on VLC media player.

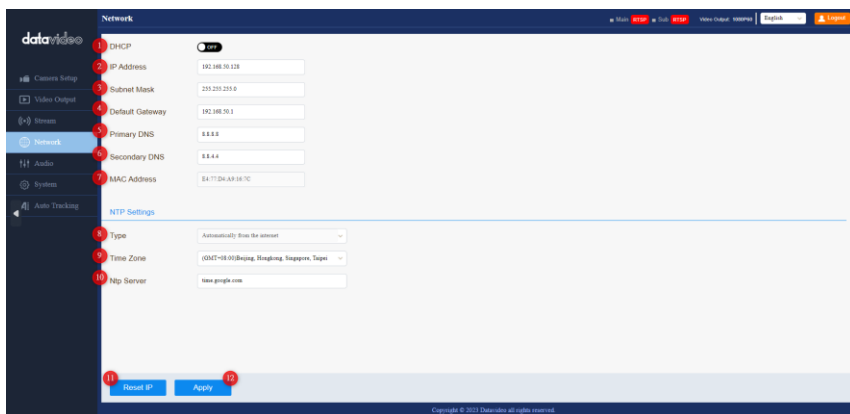
1. On the "Stream" page of the PTC-145 Web UI, select "Multicast" from the "Protocol" drop-down menu.



2. Turn on VLC, click "Media" → "Open Network Stream" and enter **udp://224.1.2.3:4000** to view the main streaming image and **udp://224.1.2.3:4002** to view the sub-streaming image.
3. Click the "Play" button to start your video stream.

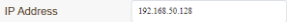
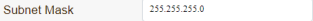

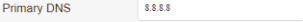
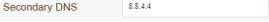
9.4 Network



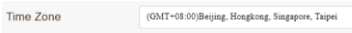
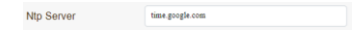
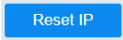
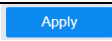
The "Network Settings" option allows you to set the PTC-145's network-related settings including "DHCP ON/OFF" switch, "IP Address", "Subnet Mask", "Default Gateway", "Primary DNS", "Secondary DNS", etc. In addition, the "Network Settings" option also allows you to set the NTP-related settings including "Type", "Time Zone", and "NTP Server". When you are done with the settings, click the "Apply" button to complete the setup. The main interface of the Network Settings option is shown below.



For the functions related to "Network Settings", please refer to the following table.

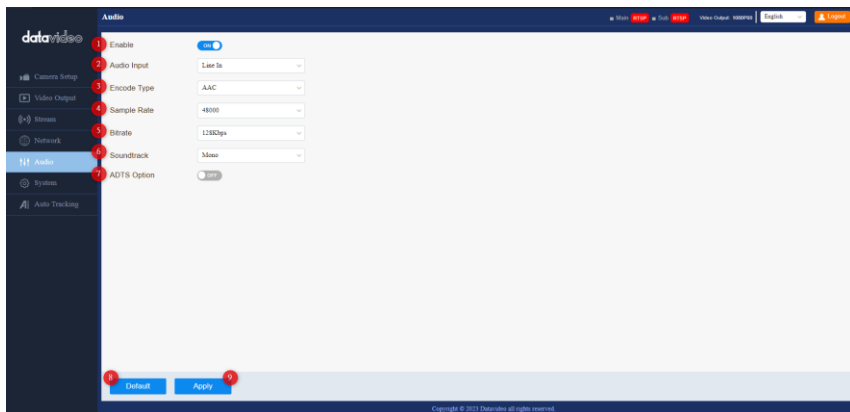
Function Keys		Descriptions
1.	DHCP <input checked="" type="checkbox"/>	DHCP ON/OFF Switch You can press this DHCP ON/OFF switch to set your camera to DHCP mode or Fixed IP mode. If it is set to "ON", it is DHCP mode, if it is set to "OFF", it is Fixed IP mode.

	Function Keys	Descriptions
2		<p>IP Address</p> <p>If your camera is set to "DHCP ON", this IP address will be automatically assigned by the router. If your camera is set to "DHCP OFF", then you need to manually fill in the fixed IP address you want. The PTC-145 is factory defaulted to DHCP mode.</p>
3		<p>Subnet Mask</p> <p>If your camera is set to Fixed IP Mode, this field allows you to manually enter the Subnet Mask value.</p>
4		<p>Default Gateway</p> <p>If your camera is set to Fixed IP Mode, this field allows you to manually enter the Gateway value.</p>
5		<p>Primary DNS</p> <p>This field allows you to manually enter the "Primary DNS" value.</p>
6		<p>Secondary DNS</p> <p>This field allows you to manually enter the "Other DNS Server" value.</p>

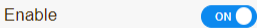

Function Keys		Descriptions
7		<p>MAC Address</p> <p>This is the MAC Address and cannot be changed.</p>
8		<p>Type</p> <p>This is the NTP (Network Time Protocol) setting type, and the default value is "Synchronize automatically from the network".</p>
9		<p>Time zone</p> <p>You can select your desired time zone from the drop-down menu.</p>
10		<p>NTP Server</p> <p>This option provides you with a Google NTP server for time correction purposes.</p>
11		<p>Reset IP</p> <p>Pressing this button resets the relevant parameters in the Network Settings option to the factory default settings.</p>
12		<p>Apply</p> <p>After you have set the relevant settings, click the "Apply" button to apply the selected settings.</p>

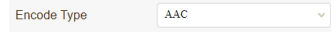
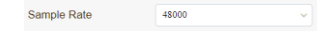

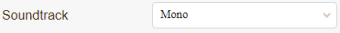

9.5 Audio

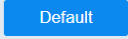
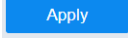
The "Audio" option allows you to set the PTC-145's settings including the "Audio Enable ON/OFF" switch, "Audio Input", "Encode Type", "Sample Rate", "Bit Rate", "Soundtrack" and "ADTS" options. The main interface of "Audio" option is shown below.



For "Audio" related functions, see the table below.

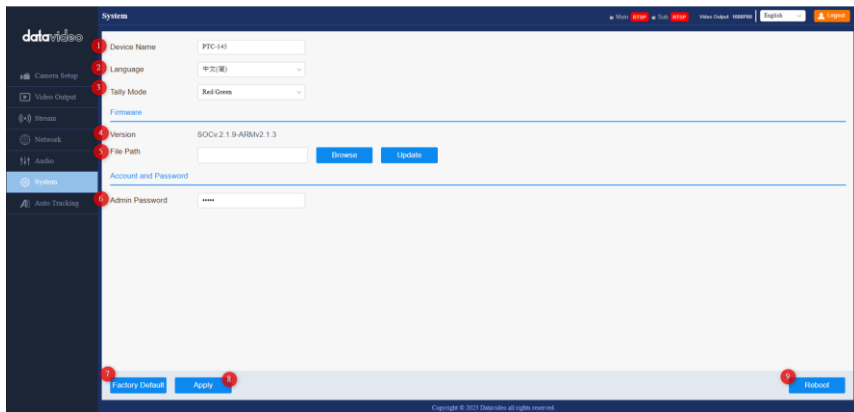
	Function Keys	Descriptions
1.		<p>Audio Enable ON/OFF Switch This option allows the user to turn the sound input on or off.</p>
2		<p>Audio Input This is the external audio input method, and the default value is Line in.</p>

	Function Keys	Descriptions
3		<p>Encode Type</p> <p>This is the encoding format of the input sound, which is AAC format by default.</p>
4		<p>Sample Rate</p> <p>This drop-down menu allows the user to select the desired sample rate for the input audio. The default value is 48K.</p>
5		<p>Bit Rate</p> <p>This drop-down menu allows the user to select the bit rate.</p>
6		<p>Soundtrack</p> <p>This option allows you to select "Mono" or "Stereo".</p>
7		<p>ADTS Option</p> <p>This ADTS ON/OFF switch allows the user to turn the ADTS function on or off. This feature is currently not available.</p>

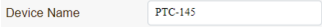

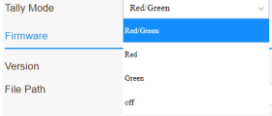
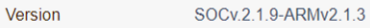
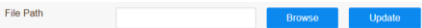
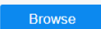
Function Keys		Descriptions
8		Default Pressing this button restores the relevant parameter in the “Audio” option to the factory default setting.
9		Apply After you have set the relevant settings, click the "Apply" button to apply the selected settings.

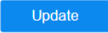
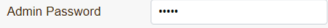
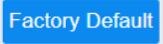
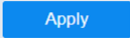
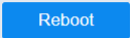
9.6 System

The "System" option allows you to set the PTC-145's “Camera Name”, “Language”, “Tally Mode”, and “Admin Password”. In addition, you can also see the current firmware version from the "Version" option. You can also click the "Browse" button to select the latest downloaded firmware file from your computer, and click the "Update" button to perform a firmware update. The main interface of the "System" option is shown below.



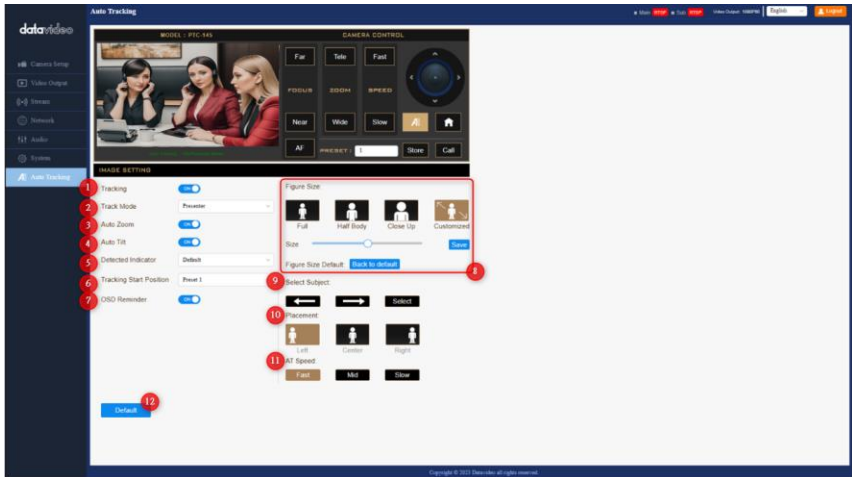
Please refer to the following table for "System" related functions.

	Function Keys	Descriptions
1.		<p>Device Name You can enter your desired camera name in this field.</p>
2		<p>Language You can use this drop-down menu to select the display language of the Web UI.</p>
3		<p>Tally Mode You can set your camera's Tally Mode from this drop-down menu, which has three modes: "Red/Green", "Red" and "Green". Selecting "Off" will disable the Tally Mode function.</p>
4		<p>Version This option displays the current firmware version.</p>
5		<p>This option allows you to select the latest firmware file for firmware update. Please click the "Browse" button  to select the latest downloaded firmware file from your computer, and</p>

Function Keys		Descriptions
		then click the "Update" button  to perform the firmware update.
6		Admin Password This option allows you to set your Admin password, which is the password you need to log in to the PTC-145 Web UI. The factory default password is "admin". When you have finished setting the password, press the "Apply" button to take effect.
7		Factory Default Pressing this button restores the relevant parameters in the "System" option to the factory default settings.
8		Apply After you have set the relevant settings, click the "Apply" button to apply the selected settings.
9		Reboot Press this button to reboot your PTC-145 camera.


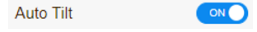
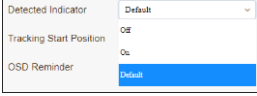
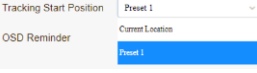
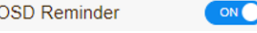
9.7 Auto Tracking

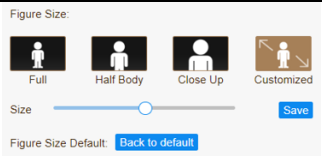

The "Auto Tracking" option allows you to set the PTC-145's "Auto Track Mode ON/OFF", "Auto Track Mode" selection, "Auto Zoom ON/OFF" switch, "Auto Tilt ON/OFF" switch, "Detect Indicator", "Tracking Start Position", "Tracking Tip", "Figure Size", "Select Object", "Placement", "AT Speed", etc. The main interface of the "Auto Track" option is shown below.

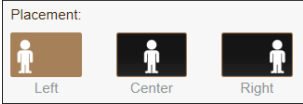

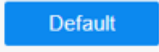


Please refer to the following table for "Auto Track" related functions.

	Function Keys	Descriptions
1.	Tracking <input checked="" type="checkbox"/> ON	Auto Track ON/OFF Switch You can use this switch to turn the camera's auto-tracking function on or off.
2	Track Mode <input type="text" value="Presenter"/>	Track Mode This is the auto-tracking mode, which is defaulted to Presenter mode.

	Function Keys	Descriptions
3		<p>Auto Zoom ON/OFF Switch</p> <p>This is the Auto Zoom ON/OFF switch, which allows you to turn the camera's auto zoom function on or off.</p>
4		<p>Auto Tilt ON/OFF Switch</p> <p>This is the Auto Tilt ON/OFF switch that allows you to turn the camera's auto pan/tilt function on and off.</p>
5		<p>Detected Indicator</p> <p>This option allows you to set whether or not to turn on the detected indicator when the camera detects a person being photographed when the camera's auto-tracking function is turned on. There are three modes to choose from: Default, On and Off. The Default value of the detected indicator is On.</p>
6		<p>Tracking Start Position</p> <p>This option allows you to set the start position of the camera's auto-tracking. There are Current Location and Preset 1 to choose from.</p>
7		<p>OSD Reminder</p> <p>This is the OSD Reminder ON/OFF switch. When set to "ON", a prompt will appear on the screen of the monitor connected to the camera when you turn on the auto tracking</p>

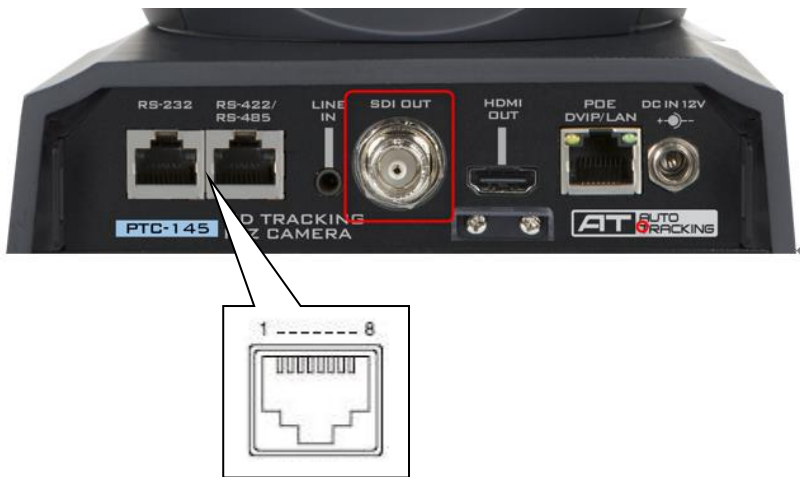
	Function Keys	Descriptions
		<p>function. If it is set to "OFF", the prompt is turned off.</p>
8		<p>Figure Size</p> <p>The Figure Size option provides four preset settings, including "Full Body", "Half Body", "Close-up" and "Customized", which allow users to adjust the angle of the people that the camera wants to capture when in auto-tracking mode. You can also use the "Size" slider to adjust the auto-tracking camera angle you want, and then press the "Save" button after adjustment to complete the setting. If you press the "Back to Default" button, you can restore the default settings of this "Figure Size" related option.</p>
9		<p>Select Subject</p> <p>When the camera's auto-tracking function is turned on, you can use the left or right arrow buttons of the "Select Subject" option to select the character you want to track. Once you have selected the character you want to track, press the "Select" button again to complete the selection.</p>

	Function Keys	Descriptions
10	 <p>The image shows a 'Placement' control panel with three buttons: 'Left' (orange), 'Center' (black), and 'Right' (black). Each button has a white person icon above it.</p>	<p>Placement</p> <p>This option allows you to set the position of the person you want to follow to be on the left, center, or right side of the screen when the camera captures the person you want to follow. There are three options for you to choose from: "Left", "Center" and "Right". Click the "Left", "Center" or "Right" button directly to complete the setting.</p>
11	 <p>The image shows an 'AT Speed' control panel with three buttons: 'Fast' (orange), 'Mid' (black), and 'Slow' (black).</p>	<p>AT Speed</p> <p>This option allows you to set your desired auto-tracking speed. There are three options for you to choose from: "Fast", "Mid", and "Slow".</p>
12	 <p>The image shows a single blue button labeled 'Default'.</p>	<p>Default</p> <p>Click this button to restore all the relevant settings of the Auto Track interface to the factory default settings.</p>

10. Remote Control Port Pin Definitions

In addition to operating the PTC-145 remotely over Ethernet, you can also operate the PTC-145 by connecting it to a computer or any external controller via an RS-232 or RS-422/RS-485 remote port. You can connect an external RS-232 or RS-422/RS-485 controller to the PTC-145 using an Ethernet cable and make your own connection cable according to the pinout definitions provided in this section.

Remote Control Port



The following are the pin definitions for the RS-232 control port.

No.	RJ-45 connector	Camera RS-232 Control Port
1	White/Orange	GND
2	Orange	NC
3	White/Green	NC
4	Blue	Transmit IN
5	White/Blue	NC
6	Green	Receive IN
7	White/Brown	Transmit OUT
8	Brown	Receive OUT

The following are the pin definitions for the RS-422/RS-485 control port.

No.	RJ-45 connector	Camera RS-422/485 Control Port
1	White/Orange	GND
2	Orange	NC
3	White/Green	RX-
4	Blue	TX-
5	White/Blue	TX+
6	Green	RX+
7	White/Brown	NC
8	Brown	NC

How to connect the PTC-145 to a 2-wire RS-485 interface

No.	RJ-45 connector	Camera RS-485 Control Port
1	White/Orange	GND
2	Orange	NC
3	White/Green	(RX-/TX-)
4	Blue	NC
5	White/Blue	NC
6	Green	(RX+/TX+)
7	White/Brown	NC
8	Brown	NC

11. Firmware Update

Firmware Update Procedure

PTC-145

This file provides procedures for updating the PTC-145 HD Tracking PTZ Camera.

Updating the PTC-145 Camera Firmware (ARM V2.1.3 2024-01-05/ SOC V2.1.9 2024-01-07/ AF Version V1.0.4 2023-10-27)

What to Prepare Before Firmware Upgrade

- The latest PTC-145 firmware update zip file x1.

The latest firmware zip file can be downloaded from the PTC-145 product page on Datavideo's official website at <https://www.datavideo.com/product/PTC-145>. After unzipping the downloaded firmware zip file, you can see two firmware files.

- **Camera & AF firmware files:** D-PTC145_NDI_SY20X_V2.1.9_R_20240107.mrg
- **MCU firmware:** PTC145_ARM_V2.1.3_20240105.mrg

- PTC-145 Camerax 1
- 12V Power Adaptor x 1
- Laptop or PC x 1
- Ethernet cable x 1

This document describes how to perform a firmware update on a Windows computer.

System Connection Diagram



[Check Firmware Version](#)

Page 115

[Before Updating the Firmware](#)

Page 118

[Updating the MCU Firmware](#)

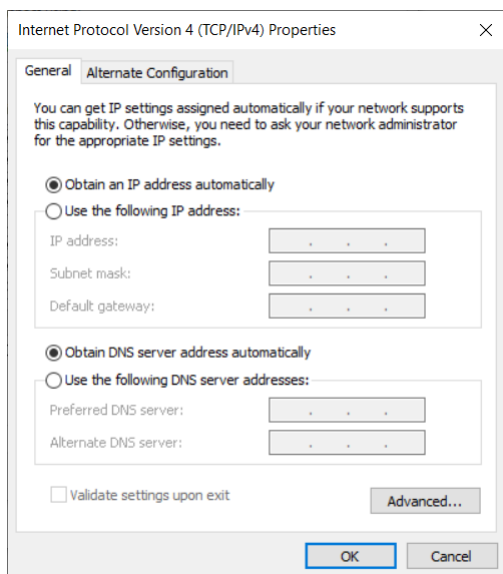
Page 121

[Updating camera and AF firmware](#)

Page 123

11.1 Check Firmware Version

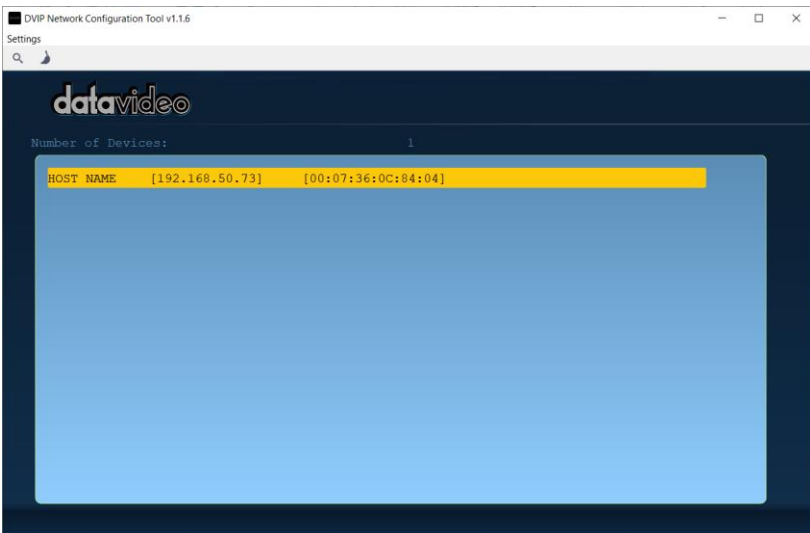
1. Connect the RJ-45 Ethernet cable from the RJ-45 Ethernet interface of your PC or laptop to one of the LAN interfaces of the router.
2. Connect the RJ-45 Ethernet cable from the "LAN" interface on the rear panel of the PTC-145 to the other LAN interface of the router.
3. Connect the DC 12V power adapter to the PTC-145 camera.
4. The factory default setting of the PTC-145 is DHCP mode. Make sure your laptop or PC is set to DHCP mode.



5. Please download the "Datavideo Network Configuration Tool" from the PTC-145 product page on Datavideo's official website <https://www.datavideo.com/product/PTC-145>
6. Double-click the DVIP Network Configuration Tool to select the Ethernet card, and then click "OK".



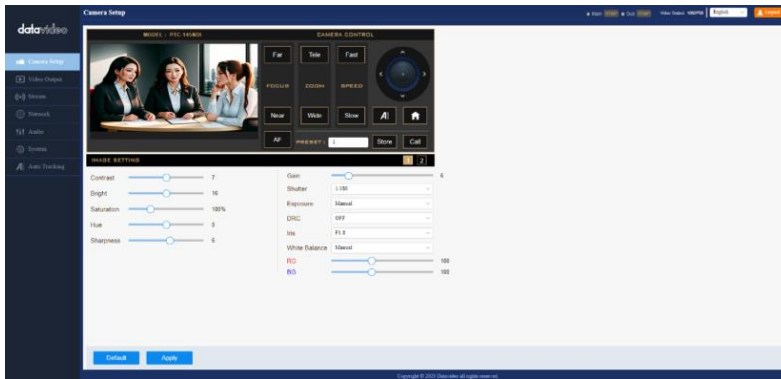
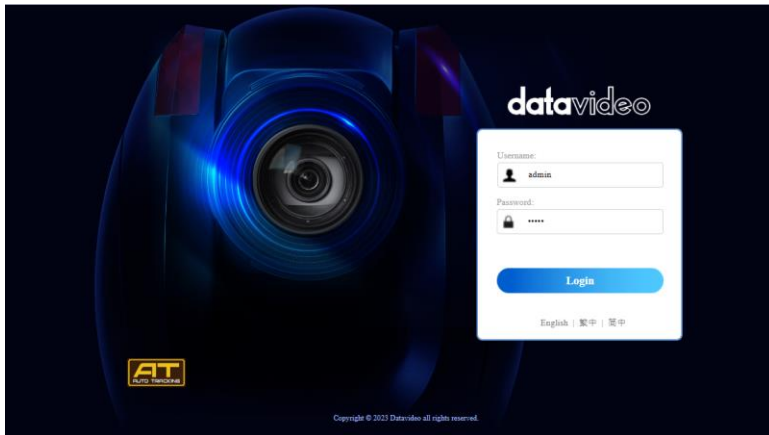
7 You can see the DHCP IP address of the PTC-145. In this example, it is "192.168.50.73".



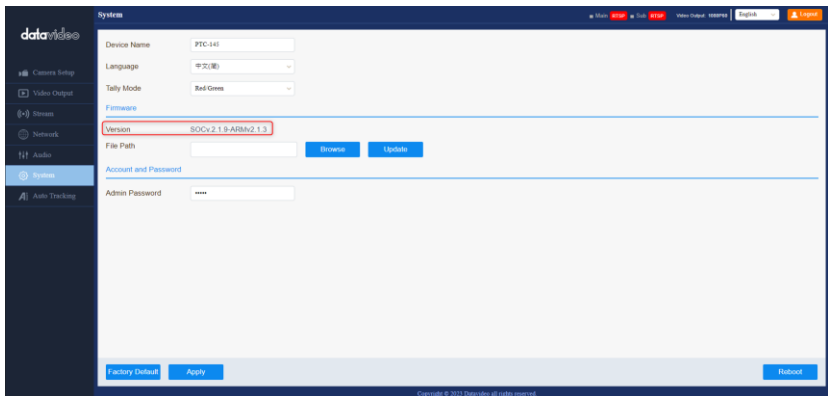
8. After obtaining the IP address of the PTC-145, enter the IP address in the browser address bar. After that, you will see the login page of PTC-145 Web UI. Please enter the default username and password for logging in to the Web UI.

Default User Name: admin

Default Password: admin

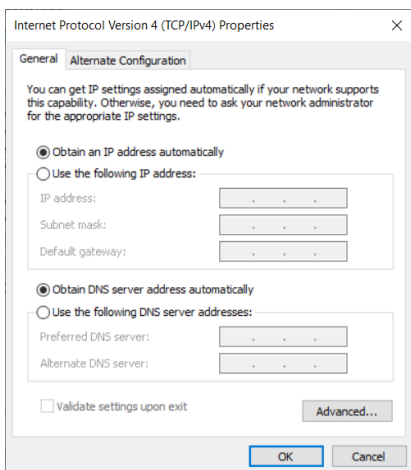


9. Click the “**System**” option to open the Firmware Update page. You will then see the current firmware version of the PTC-145 camera.



11.2 Before Updating the Firmware

1. Connect the RJ-45 Ethernet cable from the RJ-45 Ethernet interface of your PC or laptop to one of the LAN interfaces of the router.
2. Connect the RJ-45 Ethernet cable from the LAN connector on the rear panel of your PTC-145 to another LAN interface on the router.
3. Connect the DC 12V power adapter to the PTC-145 camera.
4. The factory default setting of the PTC-145 is DHCP mode. Make sure your laptop or PC is set to DHCP mode.



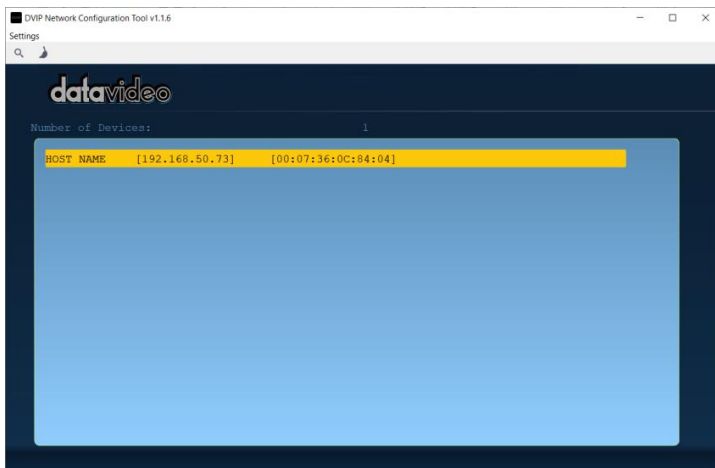
5. Please download the "Datavideo Network Configuration Tool" from the PTC-145 product page on Datavideo's official website

<https://www.datavideo.com/product/PTC-145>

6. Double-click the DVIP Network Configuration Tool to select the Ethernet card, and then click OK.



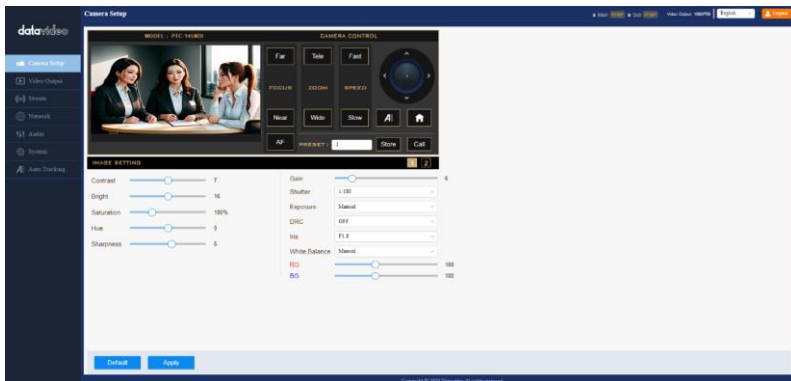
7 You can see the DHCP IP address of the PTC-145. In this example, it is "192.168.50.73".



8. After obtaining the IP address of the PTC-145, enter the IP address in the browser address bar. After that, you will see the login page of PTC-145 Web UI. Please enter the default username and password for logging into the Web UI.

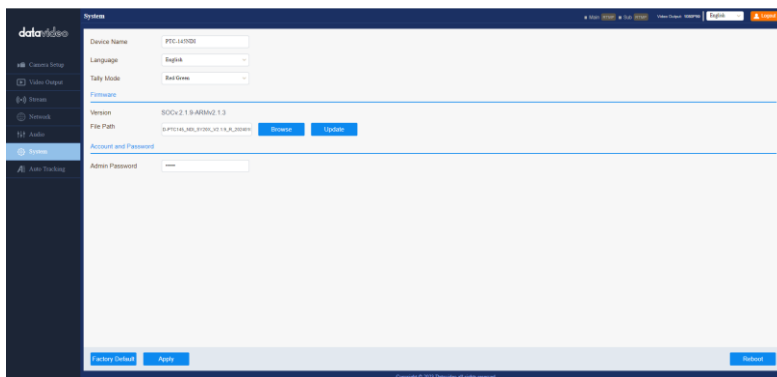
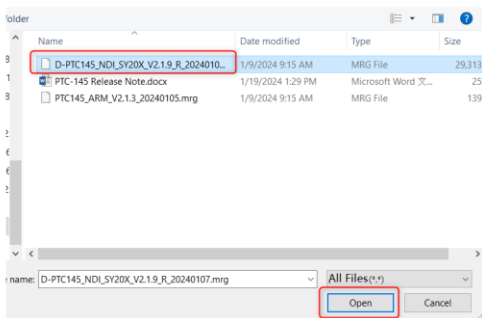
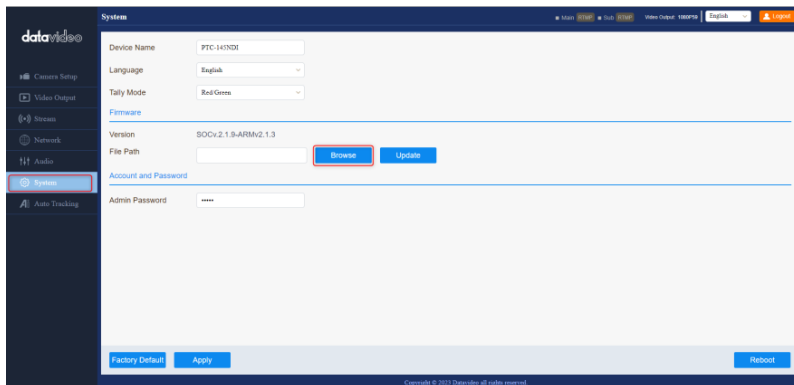
Default User Name: admin

Default Password: admin

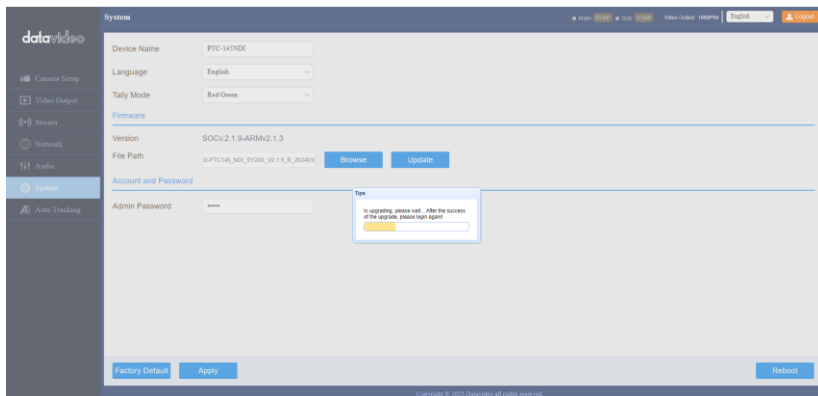


11.3 Updating the MCU Firmware

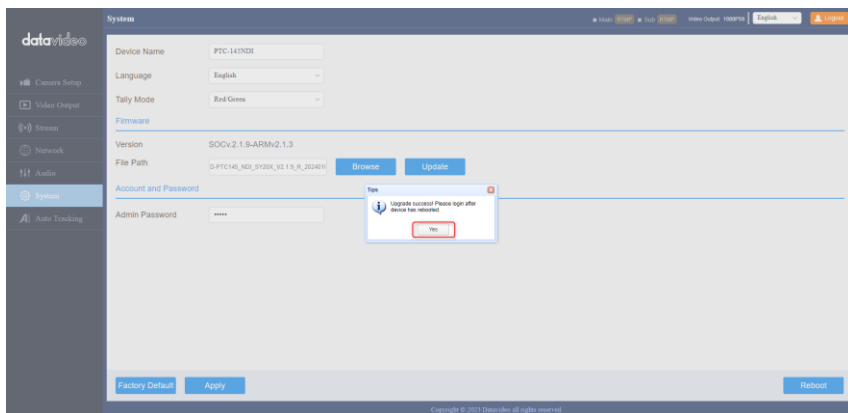
1. Please make sure that you have unzipped the downloaded firmware. Then, press **System->Browse** to select the MCU firmware file "PTC145_ARM_V2.1.3_20240105.mrg".



2. Please press the "Update" button, then the firmware update process of MCU will start automatically.

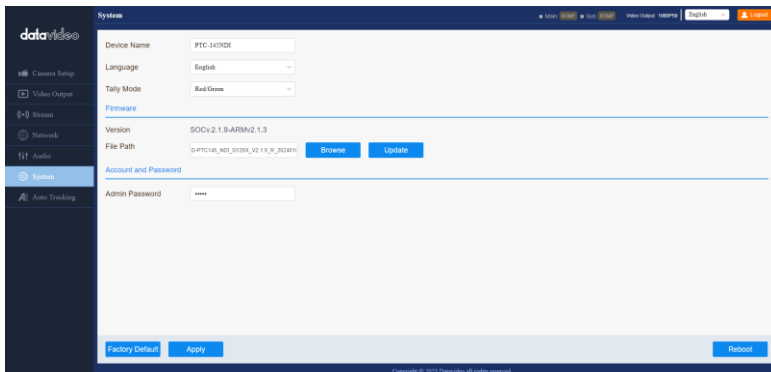
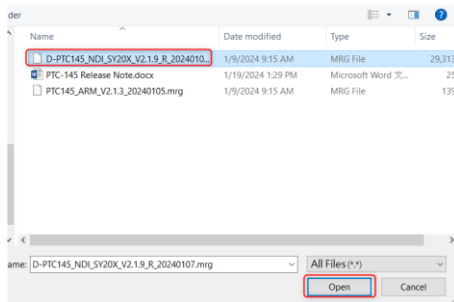
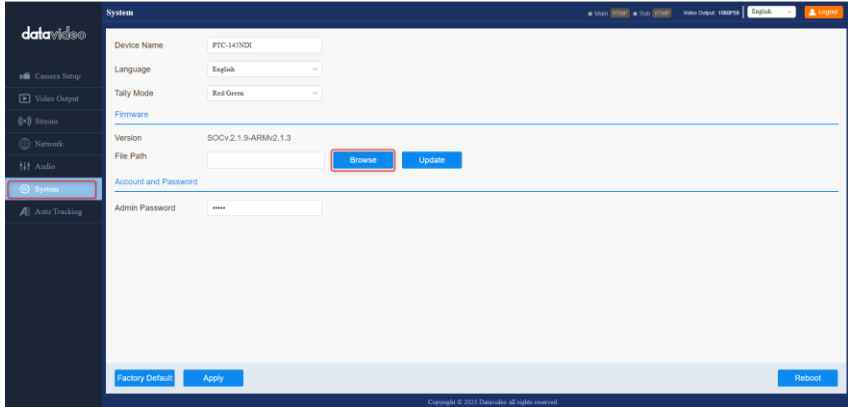


3. After the MCU firmware is updated successfully, the PTC-145 will reboot automatically. After the reboot is completed, please press the "Yes" button and log in to the PTC-145 Web UI again, then the whole MCU firmware update process is completed successfully.

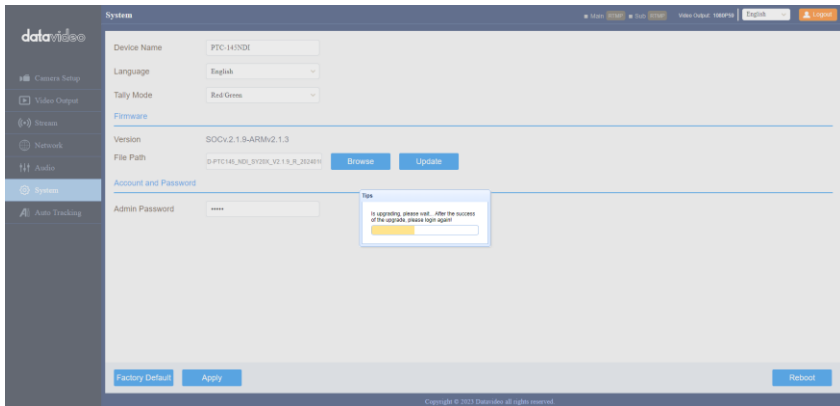


11.4 Updating camera and AF firmware

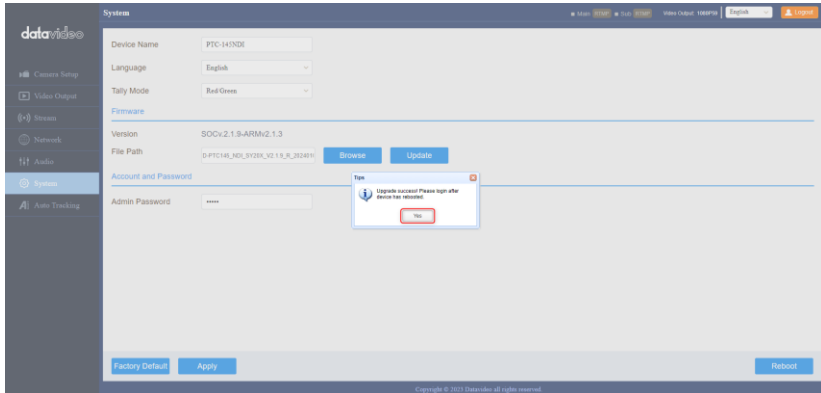
1. Make sure you have unzipped the downloaded firmware. Then, please click System->Browse to select the Camera and AF firmware files. "D-PTC145_NDI_SY20X_V2.1.9_R_20240107.mrg".



2. Press the “Update” button and the firmware update process for the camera and AF autofocus will start automatically.



3. After the camera and AF firmware have been successfully updated, the PTC-145 will automatically reboot. After the reboot is complete, press the "Yes" button and log in to the PTC-145 Web UI again. After that, the entire camera and AF firmware update process will be completed successfully.



12. Frequently-Asked Questions

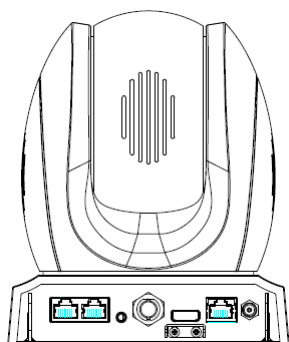
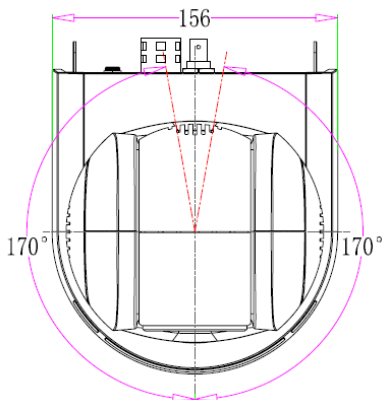
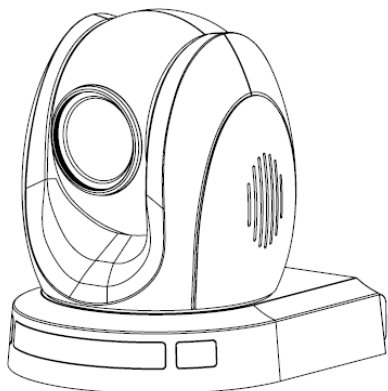
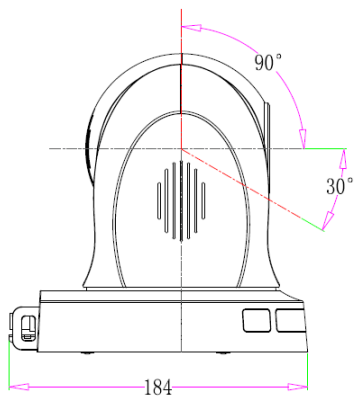
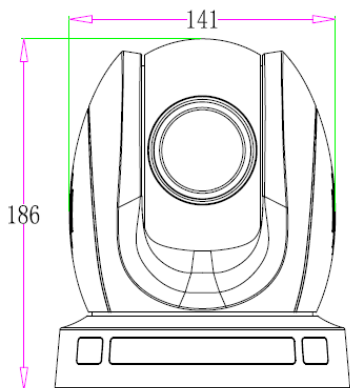
This section describes the problems you may encounter when using this product. If you have any problems, please refer to the relevant section and try the suggested solutions. If the problem persists, please contact your local dealer or service center.

No.	Problems	Solutions
1.	Important Points for Product Maintenance	<ol style="list-style-type: none">1. If the camera is not used for a long time, unplug the 12V DC power plug and disconnect the AC adapter from the AC outlet.2. Use a soft cloth or paper towel to wipe the dust off the camera case.3. If the lens of the camera has been cleaned, wipe it with a soft and dry cloth. Wipe the camera with a neutral detergent, not a strong, corrosive detergent, to avoid damage to the camera lens.
2.	No output screen	<ol style="list-style-type: none">1. Make sure that the transformer and power plug are properly connected and that the power LED is on.2. Make sure the device can self-test properly after powering off and restarting.3. Make sure the camera is properly connected to the external monitor.
3.	Image shake occurs when the camera lens is zoomed.	<ol style="list-style-type: none">1. Make sure the camera is properly installed. .2. Make sure there is no vibrating machinery or objects around the camera.
4.	The remote control does not work.	<ol style="list-style-type: none">1. Set the CAM ID to 1 and test the remote control to see if it works (the CAM ID will be set to 1 when the camera is restored to the factory default settings).2. Make sure that the battery of the remote control is properly installed and that the battery is sufficiently charged.3. Make sure the operating mode of the

		<p>device is normal.</p> <p>4. Make sure the OSD menu is closed. The remote control can only be used when the OSD is closed.</p>
5.	The camera cannot be controlled through the serial port.	<p>1. Please make sure the cables are the standard connection cables provided by our company.</p> <p>2. Make sure that the protocols, baudrates and addresses of the connected devices are the same.</p> <p>3. Make sure the cables are connected correctly.</p> <p>4. Make sure the operating mode of the device is normal.</p>
6.	You cannot log in to the Web Control Panel.	<p>1. Please check your Ethernet connection.</p> <p>2. Please check your network settings such as IP address.</p>
7.	The camera screen cannot be viewed on the preview screen.	<p>1. If you are using Microsoft Internet Explorer, the preview screen will not be displayed normally. If you are using Google Chrome, Firefox or Microsoft Edge, the preview screen will be displayed normally.</p> <p>2. If your browser is idle for a long time, the preview screen may stop responding. Try refreshing the page or logging into the Web UI again to resume normal playback.</p>

13. Dimensions

Unit: mm



14. Specifications

Product Model	PTC-145
Product Name	HD Tracking PTZ Camera
Video format/Resolution	1080p 60/59.94/50/30/29.97/25 1080i 60/59.94/50 720p 60/59.94/50
Image Sensor	1/2.8 inch high quality HD CMOS sensor
Effective Pixels (approx.)	2.07 Mega pixels
S/N Ratio	≥50dB
Min. Illumination	0.5Lux (F1.8, AGC ON)
Electronic Shutter	1/30s ~ 1/10000s
Zoom Ratio	20x Optical Zoom, 8x Digital Zoom
Gamma Control	N/A
Iris Control	Auto / Manual
Digital Noise Reductions	3D
On-Screen Display (OSD)	English, Traditional Chinese, Simplified Chinese
White Balance	Auto/Indoor/Outdoor/Manual/One Push
AGC / Gain Control	Yes
HDR/WDR	N/A
Mirror / Flip Image	Yes
Focus Mode	Auto / Manual
Panning / Tilting Range	Pan: 340° , Tilt: +90° to -30°
Panning / Tilting Speed	Pan: 0.1~60°/sec Tilt: 0.1~30°/sec
Preset	255 Position
Focal Length	f = 5.05mm (wide) to 91.49 mm (tele) F1.8(Wide) ~ F2.9(Tele)
Field of View (Horizontal, Wide)	60°

Image Compensation	Backlight Compensation
Video Output	HDMI x 1 3G-SDI x 1 RJ-45 PoE x1
Audio Input	3.5mm Line in
Tally LED	Dual color (Red, Green)
Lens Filter	M52.0 x 0.75 Thread with UV Protection
Control Protocol	Pelco-D, Peldo-P, VISCA, VISCA over IP, DVIP, ONVIF
Remote Control Interface	IR Web GUI RS-422 /RS-232/RS-485 (RJ45)
Video Compression Format	H.264/H.265/MJPEG
Audio Compression Format	AAC, G711
Audio Bitrate	96Kbps, 128Kbps, 256Kbps
HD IP Interface	10/100/1000M (RJ45)
Streaming Protocols	RTSP, RTMP(S), ONVIF, SRT(caller & listener), Multicast
First Stream Supported Resolution	1920x1080 1280x720 1024x576 960x540 640x480 640x360
Second Stream Supported Resolution	720x480 640x480 640x360 320x240
Video Bitrate	32Kbps ~ 50Mbps (Single Stream)
Video Bitrate Mode	VBR, CBR
Encoding Frame rate	50Hz: 1-50fps 60Hz: 1-60fps
POE	IEEE 802.3af

F/W Update	Via Web UI
IR Control	Yes
Camera Control Unit	RMC-180 series/ RMC-300 series/ PTZ View Assist APP
Tripod Mount	1/4-20 UNC
Optional Accessories	WM-1/ WM-10/ WM-11
Color	Dark Blue/White
Dimension (LxWxH)	156 x 184 x 186 mm
Weight	1.6Kg
Operating Temp. Range	0~40 °C
Storage Temp. Range	-10~60 °C
Power	DC 12V

Note

Note

Note

Service & Support

It is our goal to make your products ownership a satisfying experience. Our supporting staff is available to assist you in setting up and operating your system. Please refer to our web site www.datavideo.com for answers to common questions, support requests or contact your local office below.

Please visit our website for latest manual update.

www.datavideo.com/tw/product/PTC-145

datavideo
www.datavideo.com



@DatavideoUSA @DatavideoIndia2016
@DatavideoEMEA @Datavideojapan
@DatavideoTaiwan @DatavideoLatam
@DatavideoAsia @DatavideoBrasil



@Datavideo
@Datavideo_EMEA
@Datavideo_Taiwan



@DatavideoUSA
@DVTWDVCN



@DatavideoUSA
@DatavideoEurope

All the trademarks are the properties of their respective owners.