

datavideo

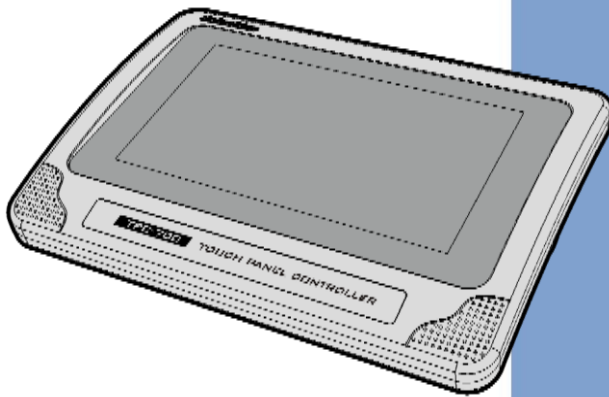

**TOUCH PANEL CONTROLLER &
TOUCH PANEL CONTROLLER
WITH PoE**

TPC-700&TPC-700P

Instruction Manual

www.datavideo.com

Table of Contents

TABLE OF CONTENTS	2
WARNINGS AND PRECAUTIONS	6
WARRANTY	7
<i>STANDARD WARRANTY</i>	7
<i>THREE YEAR WARRANTY</i>	8
DISPOSAL	9
CHAPTER 1 INTRODUCTION	10
1.1 FEATURES	10
CHAPTER 2 SYSTEM DIAGRAM	11
CHAPTER 3 CONNECTIONS	12
3.1 FRONT VIEW	12
3.2 REAR VIEW	13
3.3 LEFT VIEW	14
3.4 RIGHT VIEW	15
CHAPTER 4 HOW TO TURN ON AND TURN OFF THE POWER OF THE TPC-700/TPC-700P	16
CHAPTER 5 TPC-700 & TPC-700P'S SETTINGS OPTION	17
CHAPTER 6 BASIC SETUP	24
6.1 CONNECT BY STATIC IP ADDRESS.....	24
6.2 CONNECT BY DHCP	24
CHAPTER 7 NETWORK SETTINGS	25
7.1 CONNECT BY STATIC IP ADDRESS.....	25
7.2 CONNECT BY DHCP	30
CHAPTER 8 THE 8 PRE- SAVED VIRTUAL SCENES FOR THE SE-3200 & TPC-700/TPC-700P COMBINATION	33
8.1 THE INPUT INTERFACE SETTINGS FOR THE SE-3200 & TPC-700/TPC-700P COMBINATION.....	34

8.2 THE 8 PRE-MADE VIRTUAL SCENES FOR THE SE-3200 AND TPC-700/TPC-700P COMBINATION.....	37
CHAPTER 9. HOW TO SET THE CHROMAKEY, SAVE A STILL TO MEMORY, P-IP AND STILL FUNCTIONS.....	40
CHAPTER 10 INTRODUCTION OF THE SE-3200 APP INTERFACE FOR THE TPC-700/TPC-700P.....	41
10.1 VIRTUAL SCENES	42
10.1.1 HOW TO RECALL THE PRE-MADE VIRTUAL SCENES BY THE TPC-700/TPC-700P	46
10.2 AUX.....	47
10.2.1 HOW TO USE THE “AUX” FUNCTION	47
10.3 CROSS POINT.....	49
10.3.1 HOW TO USE THE CROSS POINT FUNCTION	49
10.4 FLEX SOURCE.....	52
10.4.1 HOW TO USE THE FLEX SOURCE FUNCTION	53
10.5 PIP.....	55
10.6 SETUP	57
CHAPTER 11. INTRODUCTION OF THE BUILT-IN VGB-2000 APP INTERFACE FOR THE TPC-700/TPC-700P	60
11.1 MAIN INTERFACE OF THE TPC-700 APP-SINGLE & DUAL.....	61
11.2 OPERATION STEPS FOR THE VGB-2000 APP FOR TPC-700/TPC-700P	63
CHAPTER 12 INTERFACE INTRODUCTION OF THE TPC-700/TPC-700P BUILT-IN DVK-400 APP	70
12.1 HOME	70
12.2 INPUT/OUTPUT	72
12.3 CHROMAKEY.....	73
12.4 LUMAKEY.....	74
12.5 WINDOW	76
12.6 USER MEMORY	77
12.7 CONNECT.....	78
12.8 SETUP	79
CHAPTER 13 INTERFACE INTRODUCTION OF THE TPC-700/TPC-700P BUILT-IN ZR-1 APP.....	85

13.1 CONNECTIONS	85
13.2 ZR-1 MAIN INTERFACE.....	86
13.2.1 3 cams Interface-Home.....	88
13.2.2 2 cams Interface-Home.....	93
13.2.3 Connection-for 3 cams & 2 cams Interfaces	95
13.2.4 Encoding-for 3 cams & 2 cams Interfaces.....	97
13.2.5 Camera-for 3 cams & 2 cams Interfaces	107
13.2.6 Switcher-for 3 cams & 2 cams Interfaces	109
13.2.7 Audio-for 3 cams & 2 cams Interfaces	116
CHAPTER 14 INTERFACE INTRODUCTION OF THE TPC-700/TPC-700P BUILT-IN TVS-2000A APP.....	118
14.1 HOME.....	118
14.2 ADVANCE.....	126
14.3 STUDIO	128
CHAPTER 15. SOFTWARE UPDATE (APP MANAGE SW)	130
CHAPTER 16. DIMENSIONS	132
CHAPTER 17. SPECIFICATIONS	133
APPENDIX.....	134
SOFTWARE UPDATE PROCEDURE FOR TPC-700 & TPC-700P	134
1. INTRODUCTION	134
2. PREPARATION	134
2.1 SYSTEM REQUIREMENTS	134
2.2 SOFTWARE UPDATE PREPARATION.....	135
2.3 SYSTEM CONNECTION DIAGRAM	136
2.4 CHECKING THE SOFTWARE VERSION	138
2.5 PREPARING THE SOFTWARE	142
3. UPDATE	142
3.1 UPDATING THE SOFTWARE	142
SERVICE AND SUPPORT	156

Disclaimer of Product & Services

The information offered in this instruction manual is intended as a guide only. At all times, Datavideo Technologies will try to give correct, complete and suitable information. However, Datavideo Technologies cannot exclude that some information in this manual, from time to time, may not be correct or may be incomplete. This manual may contain typing errors, omissions or incorrect information. Datavideo Technologies always recommend that you double check the information in this document for accuracy before making any purchase decision or using the product. Datavideo Technologies is not responsible for any omissions or errors, or for any subsequent loss or damage caused by using the information contained within this manual. Further advice on the content of this manual or on the product can be obtained by contacting your local Datavideo Office or dealer.

FCC Compliance Statement

This device complies with part 15 of the FCC rules. Operation is subject to the following two conditions:

- (1) This device may not cause harmful interference, and
- (2) This device must accept any interference received, including interference that may cause undesired operation.

Warnings and Precautions



1. Read all of these warnings and save them for later reference.
2. Follow all warnings and instructions marked on this unit.
3. Unplug this unit from the wall outlet before cleaning. Do not use liquid or aerosol cleaners. Use a damp cloth for cleaning.
4. Do not use this unit in or near water.
5. Do not place this unit on an unstable cart, stand, or table. The unit may fall, causing serious damage.
6. Slots and openings on the cabinet top, back, and bottom are provided for ventilation. To ensure safe and reliable operation of this unit, and to protect it from overheating, do not block or cover these openings. Do not place this unit on a bed, sofa, rug, or similar surface, as the ventilation openings on the bottom of the cabinet will be blocked. This unit should never be placed near or over a heat register or radiator. This unit should not be placed in a built-in installation unless proper ventilation is provided.
7. This product should only be operated from the type of power source indicated on the marking label of the AC adapter. If you are not sure of the type of power available, consult your Datavideo dealer or your local power company.
8. Do not allow anything to rest on the power cord. Do not locate this unit where the power cord will be walked on, rolled over, or otherwise stressed.
9. If an extension cord must be used with this unit, make sure that the total of the ampere ratings on the products plugged into the extension cord do not exceed the extension cord rating.
10. Make sure that the total amperes of all the units that are plugged into a single wall outlet do not exceed 15 amperes.

11. Never push objects of any kind into this unit through the cabinet ventilation slots, as they may touch dangerous voltage points or short out parts that could result in risk of fire or electric shock. Never spill liquid of any kind onto or into this unit.
12. Except as specifically explained elsewhere in this manual, do not attempt to service this product yourself. Opening or removing covers may expose you to dangerous voltage points or other risks, and will void your warranty. Refer all service issues to qualified service personnel.
13. Unplug this product from the wall outlet and refer to qualified service personnel under the following conditions:
 - a. When the power cord is damaged or frayed;
 - b. When liquid has spilled into the unit;
 - c. When the product has been exposed to rain or water;
 - d. When the product does not operate normally under normal operating conditions. Adjust only those controls that are covered by the operating instructions in this manual; improper adjustment of other controls may result in damage to the unit and may often require extensive work by a qualified technician to restore the unit to normal operation;
 - e. When the product has been dropped or the cabinet has been damaged;
 - f. When the product exhibits a distinct change in performance, indicating a need for service.

Warranty

Standard Warranty

- Datavideo equipment are guaranteed against any manufacturing defects for one year from the date of purchase.
- The original purchase invoice or other documentary evidence should be supplied at the time of any request for repair under warranty.
- The product warranty period begins on the purchase date. If the purchase date is unknown, the product warranty period begins on the thirtieth day after shipment from a Datavideo office.
- All non-Datavideo manufactured products (product without Datavideo logo) have only one year warranty from the date of purchase.

- Damage caused by accident, misuse, unauthorized repairs, sand, grit or water is not covered under warranty.
- Viruses and malware infections on the computer systems are not covered under warranty.
- Any errors that are caused by unauthorized third-party software installations, which are not required by our computer systems, are not covered under warranty.
- All mail or transportation costs including insurance are at the expense of the owner.
- All other claims of any nature are not covered.
- All accessories including headphones, cables, and batteries are not covered under warranty.
- Warranty only valid in the country or region of purchase.
- Your statutory rights are not affected.

Three Year Warranty

- All Datavideo products purchased after July 1st, 2017 are qualified for a free two years extension to the standard warranty, providing the product is registered with Datavideo within 30 days of purchase.
- Certain parts with limited lifetime expectancy such as LCD panels, DVD drives, Hard Drive, Solid State Drive, SD Card, USB Thumb Drive, Lighting, Camera module, PCIe Card are covered for 1 year.
- The three-year warranty must be registered on Datavideo's official website or with your local Datavideo office or one of its authorized distributors within 30 days of purchase.



Disposal

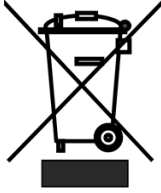

For EU Customers only - WEEE Marking

This symbol on the product or on its packaging indicates that this product must not be disposed of with your other household waste. Instead, it is your responsibility to dispose of your waste equipment by handing it over to a designated collection point for the recycling of waste electrical and electronic equipment. The separate collection and recycling of your waste equipment at the time of disposal will help to conserve natural resources and ensure that it is recycled in a manner that protects human health and the environment. For more information about where you can drop off your waste equipment for recycling, please contact your local city office, your household waste disposal service or the shop where you purchased the product.

Chapter 1 Introduction

Datavideo TPC-700/TPC-700P is the best assistant for all 3200 switchers, and VGB-2000 presentation system. The SE-3200 and VGB-2000 Apps that are installed on the TPC-700/TPC-700P contain presets of common operation functions. Just tap on the screen to easily select different presets. Each button can be customized to your liking. Multi-camera Virtual Studio switching, AUX output, Crosspoint, Flex Source, and PIP assignment can be done by the TPC-700/TPC-700P. Easy to transport to your live production show on the go. Quick connection. Simple installation.

1.1 Features

- The Touch Panel supports 800 x 480 resolution.
- Supports Wall mount installation and complies to standard VESA dimensions: 10cm x 10cm
- 7" Capacitive Touch Panel
- Supports PoE Power Supply(For TPC-700P Only)

Chapter 2 System Diagram

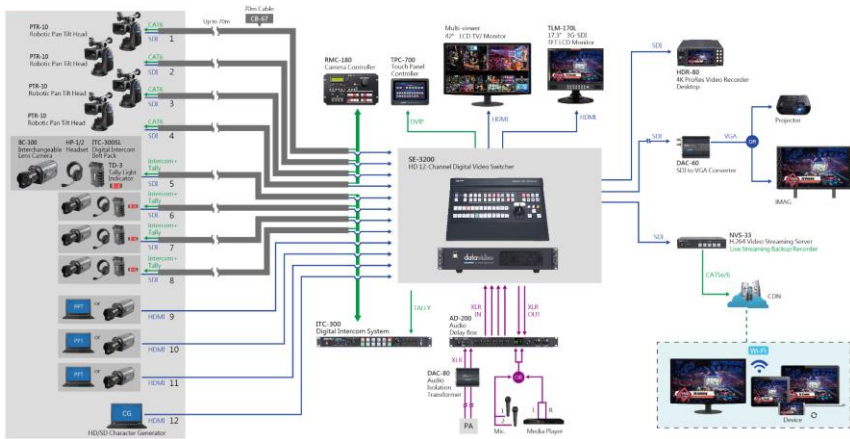

Chapter 3 Connections

This chapter will show you the connections of the TPC-700/TPC-700P Touch Panel Controller. For the details of the TPC-700/TPC-700P, please refer to following chapters.

3.1 Front View

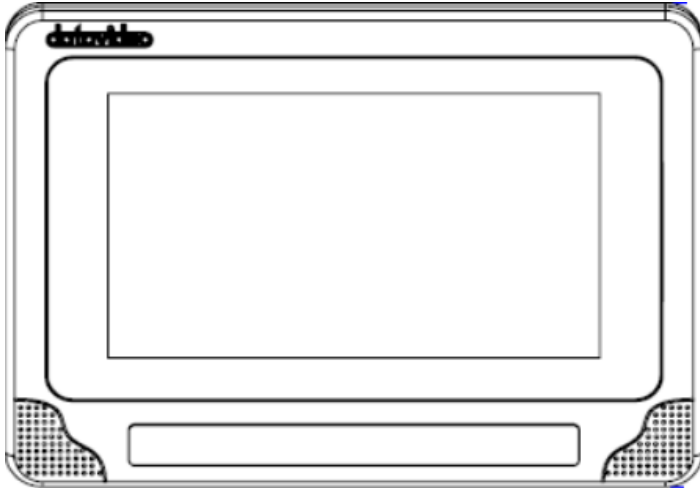

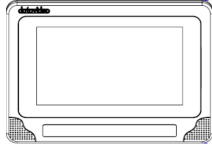
Interface	Description
	<p>Touch Panel This is the touch panel of the TPC-700/TPC-700P touch panel controller.</p>

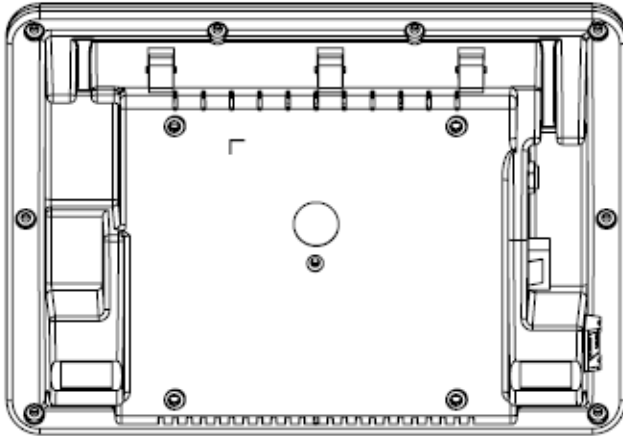

3.2 Rear View

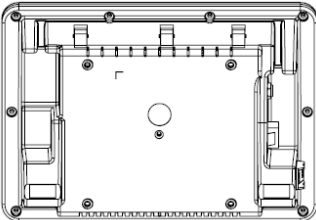

Interface	Description
	<p>Rear Panel This is the rear panel of the TPC-700/TPC-700P Touch Panel Controller. It provides standard VESA 10cm x 10cm mounting holes.</p>

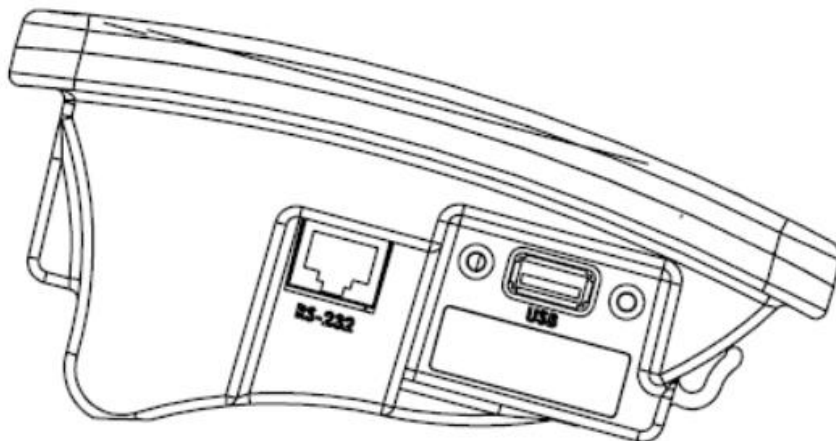

3.3 Left View

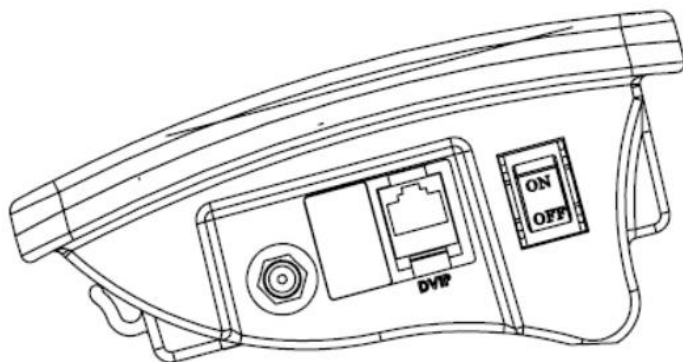

Interface	Description
	<p>RJ-45 Ethernet Interface (for RS-232 Control only)</p> <p>This RJ-45 interface is for RS-232 Control only. If users use the TPC-700/TPC-700P to control the SE-3200, it is no need for this interface to connect due to that the TPC-700/TPC-700P adopts the DVIP protocol to control the SE-3200.</p>
	<p>USB Interface</p> <p>Users can use this USB interface for updating the software and for installing the remote control software of other models.</p>

3.4 Right View



Interface	Description
	<p>12VDC IN interface Please connect a 12V DC power cable to this interface for powering the TPC-700/TPC-700P.</p>
	<p>RJ-45 Ethernet Interface (For DVIP Control & PoE Only) Please connect one end of an RJ-45 Ethernet cable to this interface and then please connect the other end of this cable to the device that must be controlled by the DVIP protocol. This interface can be used for supporting the PoE (802.3af) Power Supply. Note: The PoE function can be used only for the TPC-700P.</p>
	<p>ON/OFF Power Switch Users can turn on or turn off the power of the TPC-700/TPC-700P by this switch.</p>

Chapter 4 How to turn on and turn off the power of the TPC-700/TPC-700P

- How to Turn On the Power

Please use the ON/OFF power switch which is located on the right side of the TPC-700/TPC-700P to turn on the power of the TPC-700/TPC-700P.

- How to Turn Off the Power

- Use the ON/OFF switch: Please use the ON/OFF power switch which is located on the right side of the TPC-700/TPC-700P to turn off the power of the TPC-700/TPC-700P
- Use the APP: There is a Power-Off button which is located at the bottom side of the TPC-700 APP. Press this button can turn off the power of the TPC-700/TPC-700P.

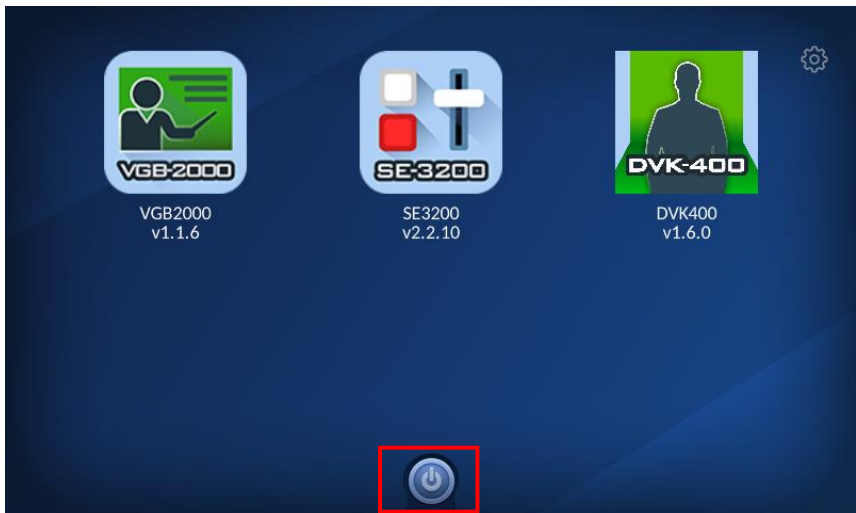

Chapter 5 TPC-700 & TPC-700P's Settings Option

After you turn on the TPC-700 or the TPC-700P, it will enter the main screen and there is a “Settings” icon which is located at the top-right side of the main screen.

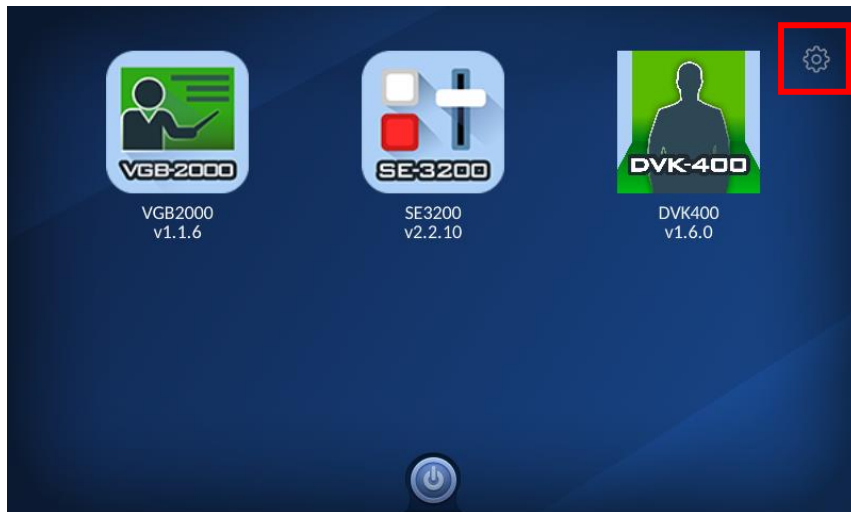

After pressing the icon, you can enter the “TPC-700 Setup” interface, the purpose for this “TPC-700 Setup” page is for you to set various network parameters of the TPC-700/TPC-700P. Moreover, it also allows you to install and uninstall various apps for different product models which are installed in the TPC-700 or the TPC-700P. In the “TPC-700 Setup” interface, there are several parameters including “Language”, “TPC-700 Network”, “App Manage”, “Autorun last App” and “FW Version”. The main interface of the “TPC-700 Setup” is shown in the following diagram, please refer to following paragraphs for details.



- Language: Please press this button to select your desired language from three languages including traditional Chinese, English and simplified Chinese. After that, please press the “Save” button for saving the settings.



- TPC-700 Network: Please press this key to set various network related parameters including DHCP ON/OFF switch, IP address, Network Mask, Gateway and Primary DNS. The main interface of the “TPC-700 Network” option is shown in the following diagram.



- DHCP ON/OFF Toggle Switch: If you connect the TPC-700/TPC-700P and your DVK-400 to the same router and then this ON/OFF toggle switch is set to “ON”, the TPC-700/TPC-700P will obtain the IP address automatically from the router. If this ON/OFF toggle switch is set to “OFF” and then you need to set the static IP address and related network parameters manually by yourself.
- IP Address: If the DHCP ON/OFF toggle switch is set to “OFF” and then you need to set the static IP address manually from this section. After the static IP address is entered, please tap the “OK” button for applying it.
Note: Please pay attention that the static IP address of the TPC-700/TPC-700P must be within the same LAN according to the default static IP address of the connected Datavideo product.

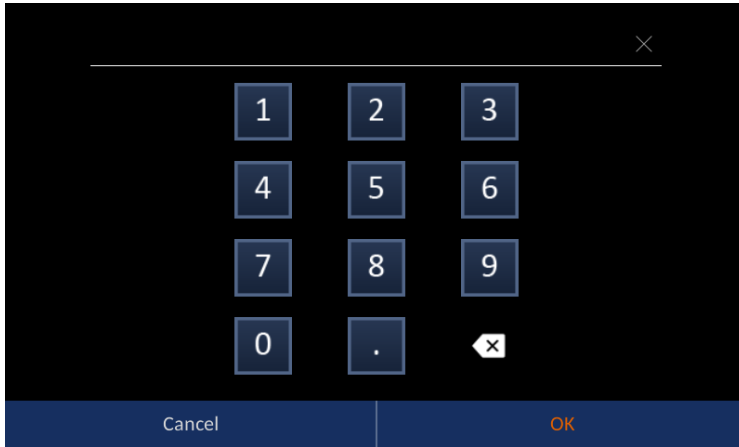

- Network Mask: Please press this button for setting the Network Mask manually. The default Network Mask is 255.255.255.0
- Gateway: Please press this button for setting the Gateway address manually. Please refer to user manuals of different product models for setting this value in consistent with the default value of each product.

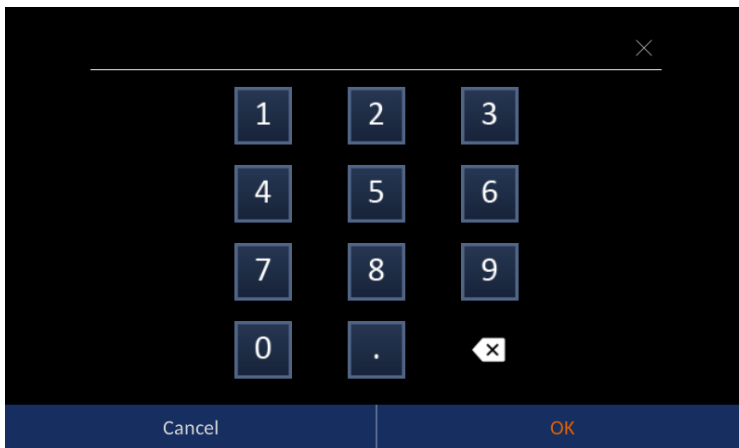

- Primary DNS: Please press this button for setting the primary DNS address, the default primary DNS address is 8.8.8.8.
- MAC Address: This section will show the MAC Address of the TPC-700/TPC-700P.
- APP Manage: Press this button allows you to install related Apps for the Datavideo products in the TPC-700/TPC-700P. The main interface of the “App Manage” option is shown in the following diagram.

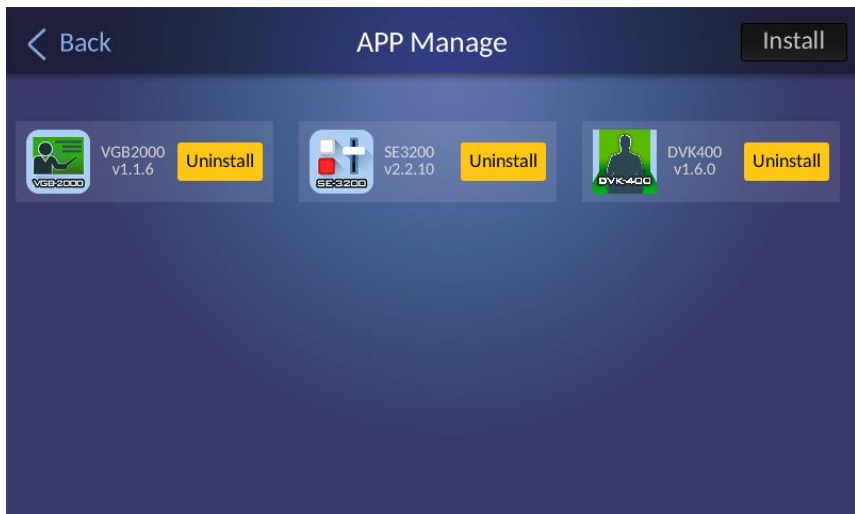

- How to uninstall the App
 1. Please press the “Uninstall” button beside the product App that is needed to be uninstalled. After that, the App will be uninstalled automatically.
 2. A reminding dialogue box will be shown. Please press the “OK” button and then the app will be uninstalled.

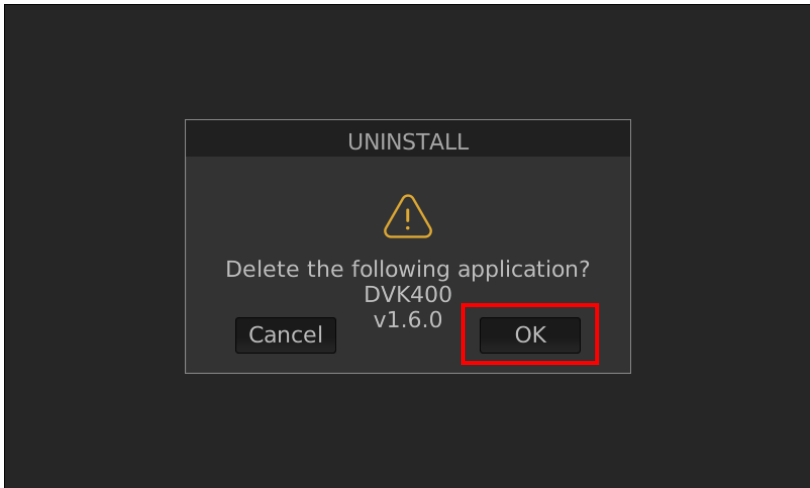

➤ How to install App

1. Please download App file for your product model from Datavideo official website <https://www.datavideo.com>. The file name is “SE-3200 firmware for TPC-700P_V2.2.10.zip” (Take SE-3200 as an example).
 2. Please unzip the downloaded zip file. After that, please unzip the “product model name_vx.x.x.zip” and then you will see a “datavideo” file folder with “tpc700.apkg” file in it. Please copy the whole “datavideo” file folder into the root directory of your USB flash drive.
 3. Please insert the USB flash drive into the USB interface which is located at the left side of the TPC-700/TPC-700P controller.
 4. Please press the “Install” button which is located at the top-right side of the “App Manage” interface and then the App will be installed automatically.
- Autorun last App ON/OFF toggle switch: If this toggle switch is “ON”, for the next time when the TPC-700 or the TPC-700P is turned on, it will run the app which is operated for the last time automatically.

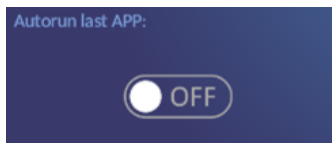

- FW Version: This section will show current version number of the “App Manage” software which is installed in the TPC-700 or the TPC-700P.

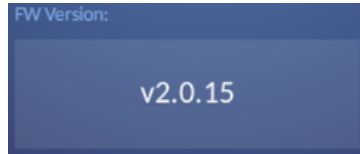

- LCD Backlight: This slider allows you to adjust the LCD Backlight brightness with the range of 20%-100%.



Chapter 6 Basic Setup

Before using the TPC-700/TPC-700P to control other devices, please make sure that the basic setup of the TPC-700/TPC-700P is done. This chapter will make the SE-3200 HD 12-Channel Digital Video Switcher as an example for explaining how to set the basic setup between the TPC-700/TPC-700P and the SE-3200. Please set the basic setup of the TPC-700/TPC-700P according to following steps.

6.1 Connect by Static IP Address

1. Please use an RJ-45 Ethernet cable to connect from the Ethernet interface on the rear panel of the SE-3200 to the DVIP RJ-45 Ethernet interface on the right side of the TPC-700/TPC-700P.

6.2 Connect by DHCP

1. Please use an RJ-45 Ethernet cable to connect from the Ethernet interface on the rear panel of the SE-3200 main unit to the RJ-45 Ethernet interface on your router.
2. Please use an RJ-45 Ethernet cable to connect from the DVIP RJ-45 Ethernet interface on the right side of the TPC-700/TPC-700P to the RJ-45 Ethernet interface of the same router.

Chapter 7 Network Settings

For the network settings of the TPC-700/TPC-700P, please see following chapters.

7.1 Connect by Static IP Address

- **If the TPC-700/TPC-700P and the SE-3200 are brand new devices.**

The default value of the **brand new** SE-3200 switcher is the static IP mode and the static IP address is **192.168.100.101**. For the brand new TPC-700/TPC-700P Touch Panel Controller, its default network mode is the static IP address mode and the IP address is **192.168.100.102**. If users want to connect the TPC-700/TPC-700P to the SE-3200 by the static IP mode, please connect the TPC-700/TPC-700P and the SE-3200 with an RJ-45 Ethernet cable.

- **If the IP address of the TPC-700/TPC-700P or the SE-3200 is not the default value**

If the IP address of the SE-3200 is not the default value, please refer to “**Network and Software Setup for Switcher**” in the SE-3200 user manual to know the IP address, subnet mask and default gateway of the SE-3200. And then please set the IP address of the TPC-700/TPC-700P to be within the same IP range for further operation.

Please follow following steps for operation.

1. After the TPC-700 or the TPC-700P is turned on, please tap the “Settings” icon.

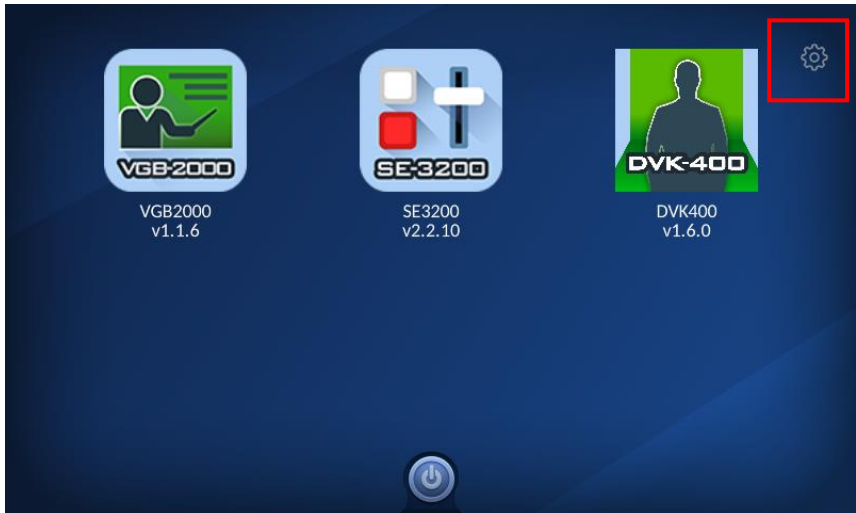

2. Please press the “TPC-700 Network” option.



3. Please turn "ON" the "DHCP ON/OFF" toggle switch. After that, you can see the default static IP address of the "TPC-700/TPC-700P" is 192.168.100.102. The default "Network Mask" is 255.255.255.0. The default "Gateway" address is 192.168.100.1.

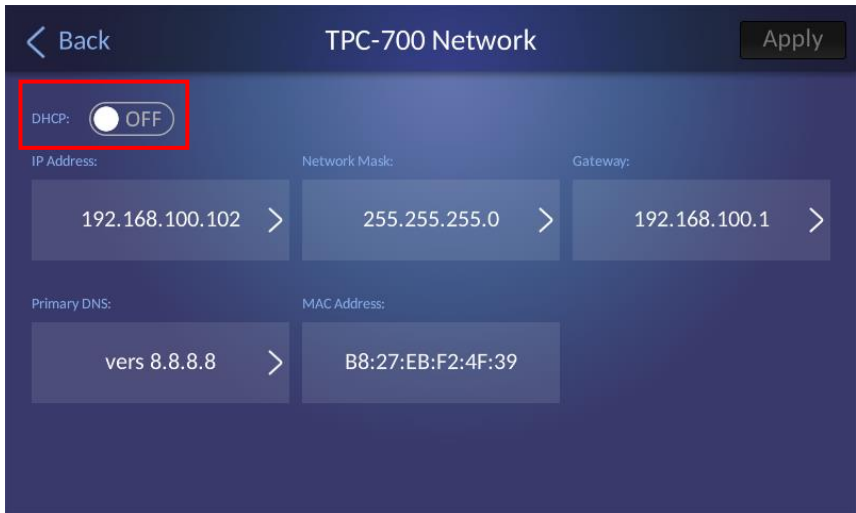

Note: If SE-3200's IP address is not the default IP address, you need to click the "IP Address" button for setting the SE-3200 and TPC-700/TPC-700P's IP addresses within the same LAN by using the keypad which is shown in the following diagram. After that, please click the "OK" button.

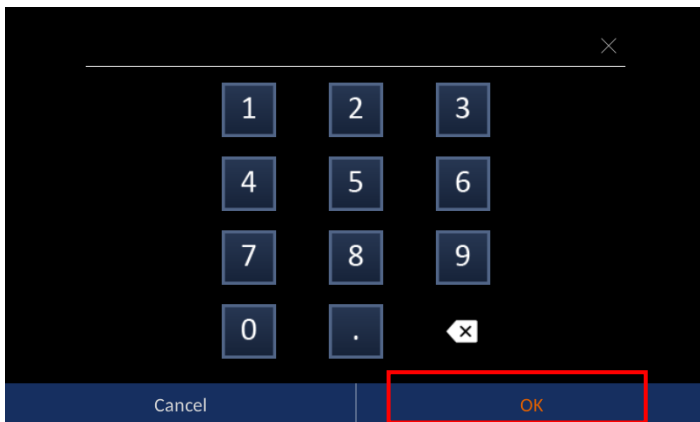

4. After going back to the “TPC-700 Network” screen, please press the “Apply” button which is located at the top-right side for applying the settings.



5. After going back to the main interface of the TPC-700/TPC-700P, please tap the SE-3200 App.

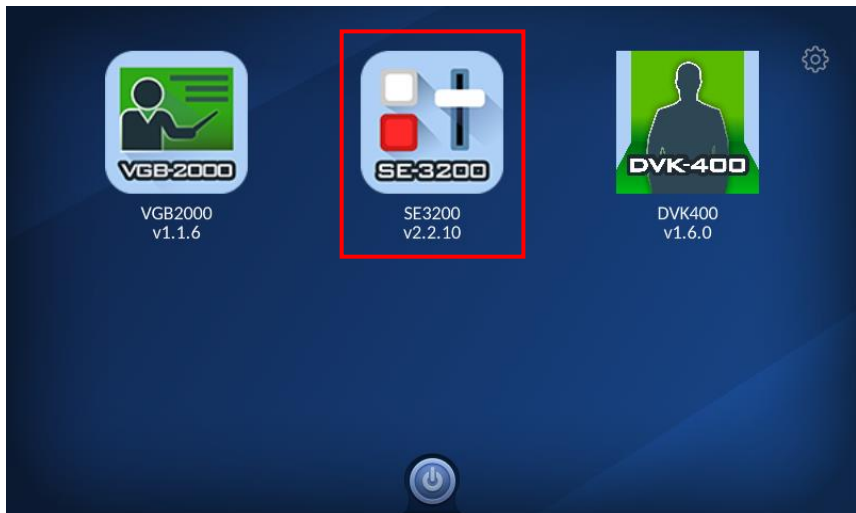

6. After entering the SE-3200 App, please click the “Setup” and then click the “Connect” button.

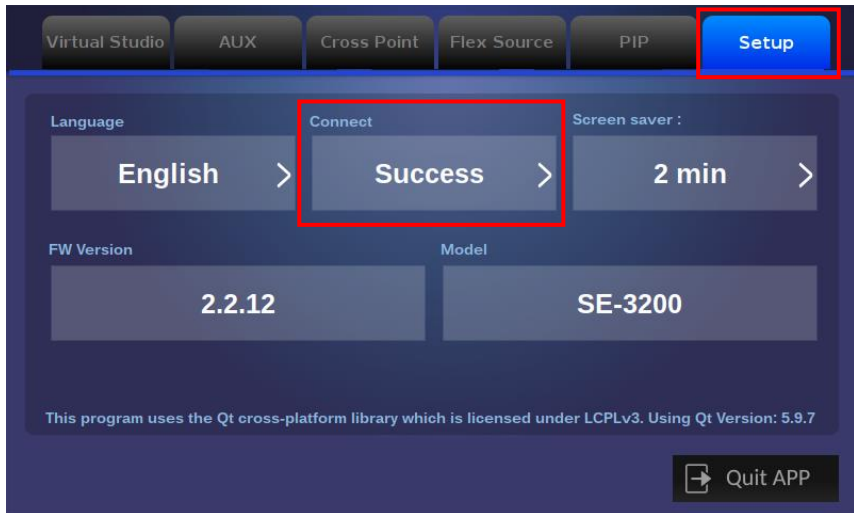

7. Please press the “Scan” button to find the connected SE-3200. After that, please select the correct SE-3200 IP address from the drop-down menu and then please press the “Connect” button for connecting the SE-3200 by the TPC-700/TPC-700P.

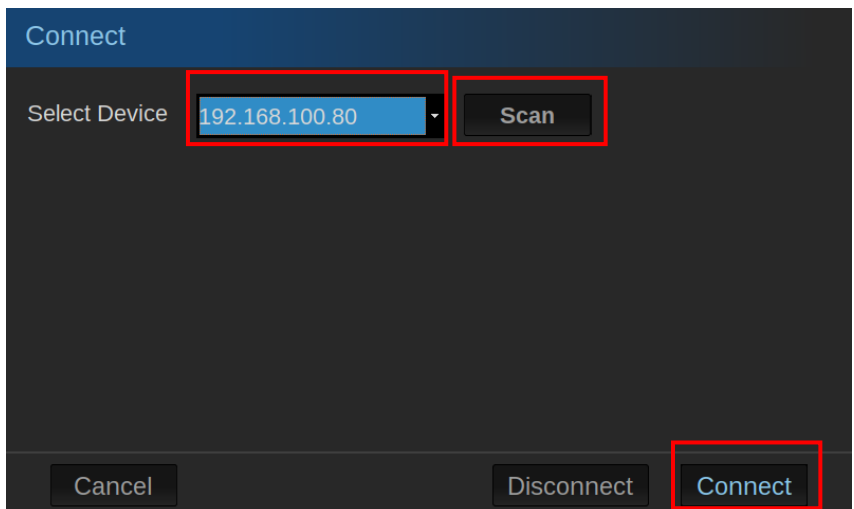

7.2 Connect by DHCP

Please follow following steps for connecting the TPC-700/TPC-700P and the SE-3200 by the DHCP Mode.

1. After the TPC-700 or the TPC-700P is turned on, please tap the “ Settings” icon.

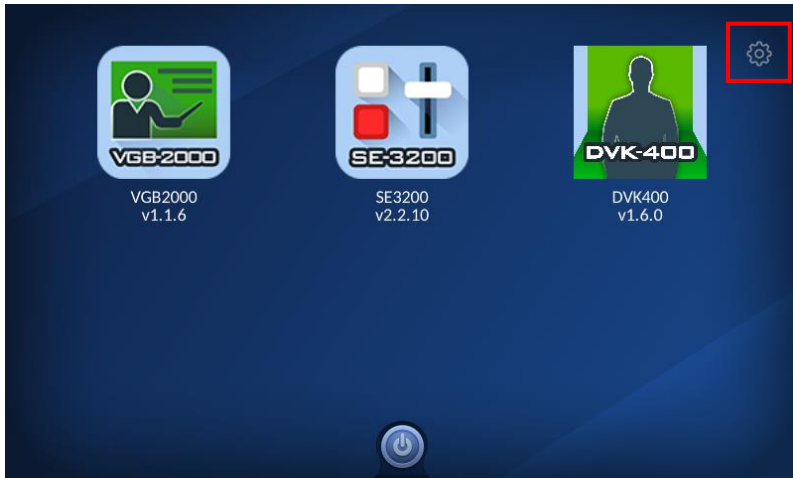

2. Please tap the “TPC-700 Network” option.

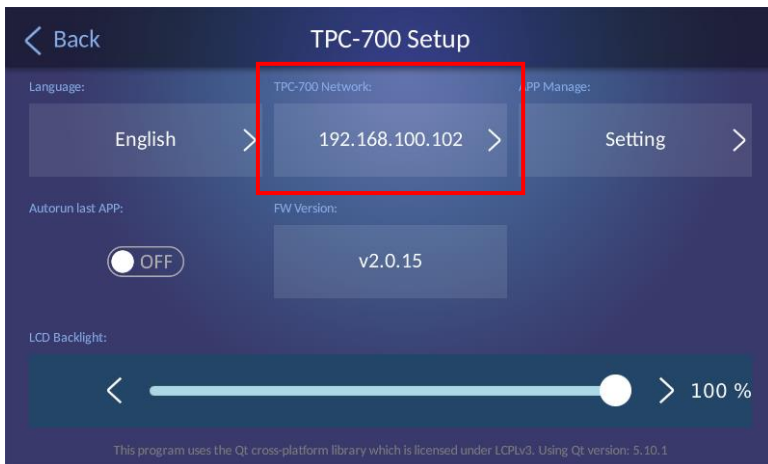

3. Please turn “ON” the “DHCP ON/OFF” toggle switch. After that, the TPC-700 or the TPC-700P will obtain the network related parameters including IP address, Network Mask, Gateway AND Primary DNS from the connected router automatically. After all parameters are obtained, please press the “Apply” button for applying the settings.



4. After going back to the main interface of the TPC-700/TPC-700P, please tap the SE-3200 App.

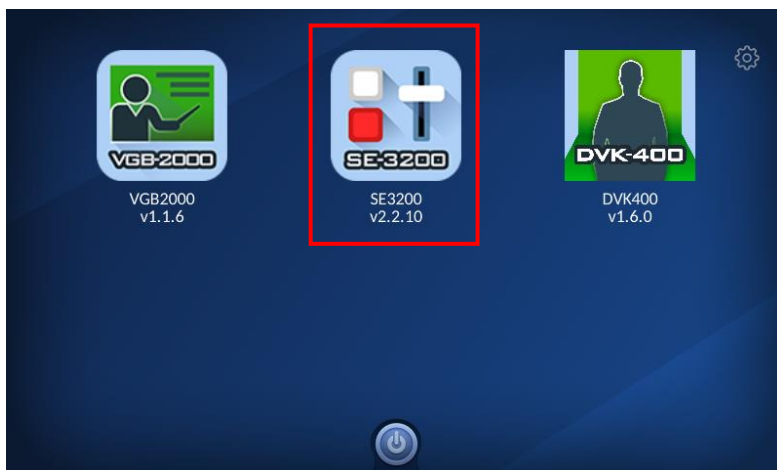

5. After entering the SE-3200 App, please tap the “Setup” option and then click the “Connect” button.

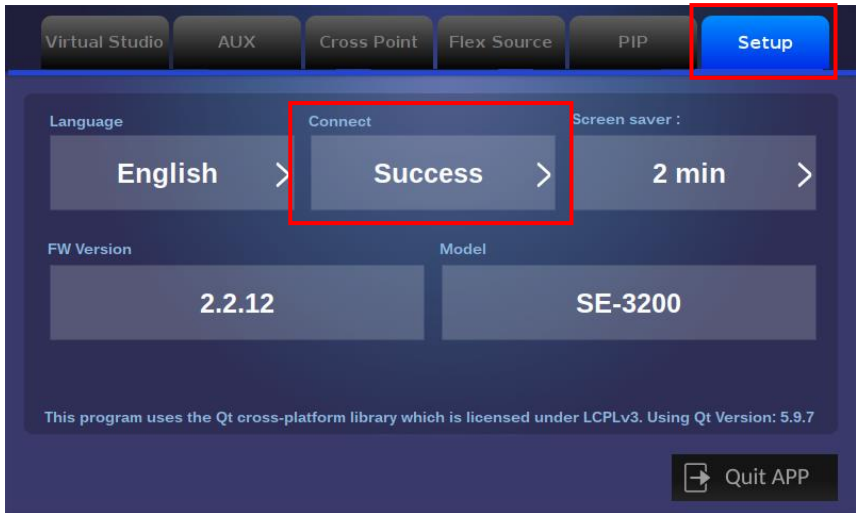

6. Please click the “Scan” button to find the connected SE-3200. Please select the IP address of the connected SE-3200 from the drop-down menu and then tap the “Connect” button to connect the TPC-700/TPC-700P to the SE-3200.

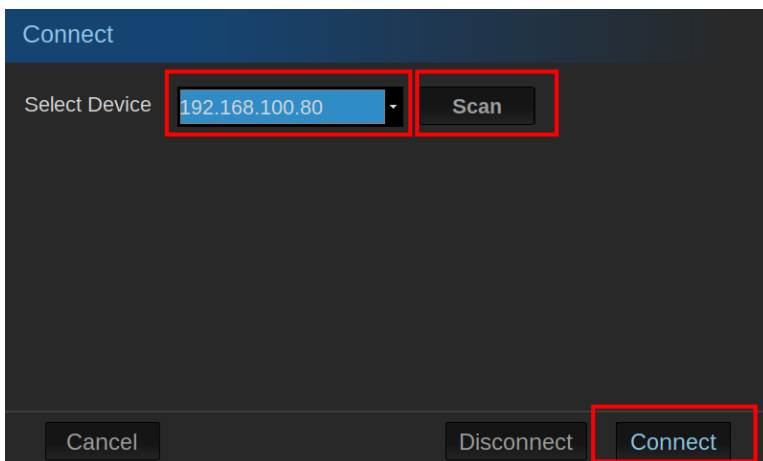

Chapter 8 The 8 Pre-saved Virtual Scenes for the SE-3200 & TPC-700/TPC-700P combination

Datavideo SE-3200 HD 12-Channel Digital Video Switcher allows users to set up to 4-camera EFP Chromakey effect. So, the SE-3200 & TPC-700/TPC-700P combination allows users to recall the pre-saved 4-camera EFP Chromakey effect virtual scenes easily and rapidly. The default setting for the TPC-700/TPC-700P is that the TPC-700/TPC-700P will recall the No. 101~No. 108 virtual scenes that are pre-saved in the SE-3200. So, please follow following steps for setting the related “User Memory” contents. Please see the example which is shown as following diagram.

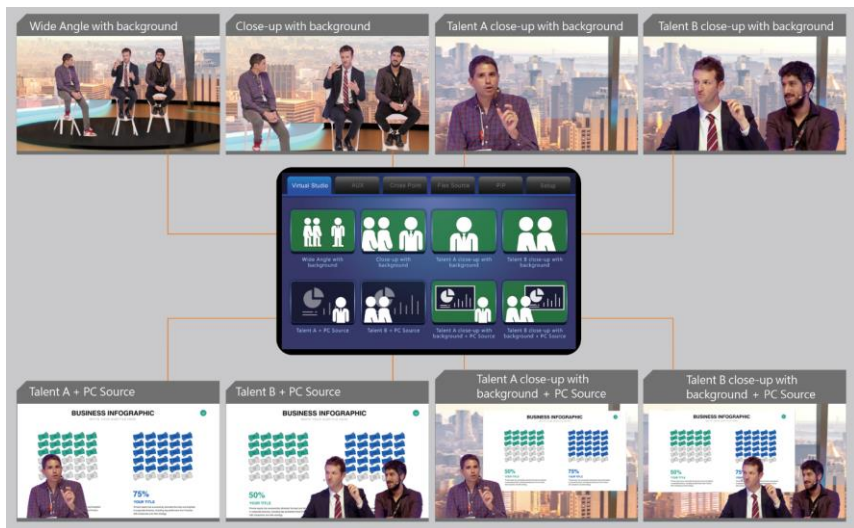

8.1 The Input Interface Settings for the SE-3200 & TPC-700/TPC-700P Combination

Before recalling the No. 101 to No. 108 user memories' virtual scenes, users need to know the corresponding relationship between each interface of the SE-3200 rear panel and the elements for each pre-saved virtual scene.

Connections for the SE-3200 rear panel	Reminders for Setting up the Cameras
SDI IN 1 (CH1)	<ul style="list-style-type: none"><li data-bbox="337 533 1033 639">• Please set the Camera 1 in the middle to shoot the full body shot for the talent and guests who are sitting in front of the green mat. (Wide Angle). 

SDI IN 2
(CH2)

- Please set the Camera 2 in the middle to shoot the close-up for the talent and guests who are sitting in front of the green mat.



SDI IN 3
(CH3)



- The Camera 3 must be set on the right side to shoot the close-up for the talent who is sitting in front of the green mat.



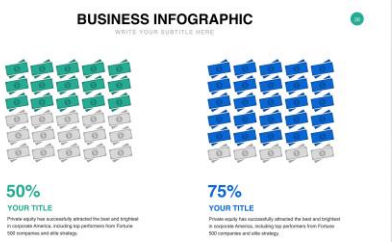





<p>SDI IN 4 (CH4)</p>	<ul style="list-style-type: none"> The Camera 4 must be set on the left side to shoot the close-up for the guests who are sitting in front of the green mat. 
<p>CH5</p>	<p>The built-in virtual scene from the SE-3200(Wide Angle virtual scene)</p>
<p>CH6</p>	<p>The built-in virtual scene from the SE-3200(The close-up picture is located in the middle)</p>
<p>CH7</p>	<p>The built-in virtual scene from the SE-3200(The picture is located at the left side)</p>
<p>CH8</p>	<p>The built-in virtual scene from the SE-3200(The picture is located at the right side)</p>

CH9	<p>Please connect a PC to the HDMI IN9 interface of the SE-3200(CH9)(for playing slides or videos)</p> <div style="text-align: center;">  </div>
-----	---

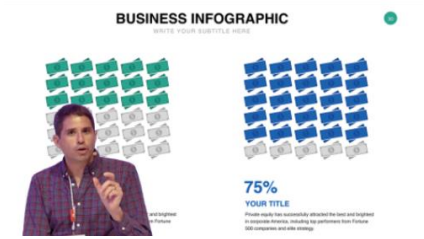
8.2 The 8 Pre-saved virtual scenes for the SE-3200 and TPC-700/TPC-700P Combination

User No.	Combination of Screen Elements	Final Composite Screen
101	<p>Wide Angle with Background</p> <p>(CH1 Chromakey+CH5 Virtual Scene)</p>	<p>Full-Body Chromakey with Virtual Scene</p> 
102	<p>Close-up with Background (CH2 Chromakey+CH6 Virtual Scene)</p>	<p>Half-Body Chromakey with Virtual Scene</p> 

103	Talent A Close-up with Background (CH3 Chromakey+CH7 Virtual Scene)	<p>Half-Body Talent A Chromakey with Virtual Scene</p> 
104	Talent B Close-up with Background (CH4 Chromakey +CH8 Virtual Scene)	<p>Talent B Chromakey with Virtual Scene</p> 
105	Talent A+PC Source (CH3 Chromakey+CH9 Background)	<p>Talent A Half-Body + Content</p> 

<p>106</p>	<p>Talent B+ PC Source (CH4 Chromakey+CH9 Background)</p>	<p>Talent B Half-Body +Content</p>  <p>The image shows a business infographic slide titled "BUSINESS INFOGRAPHIC" with the subtitle "WRITE YOUR SUBTITLE HERE". The slide features two bar charts: one with green bars and a "50% YOUR TITLE" label, and another with blue bars and a "75% YOUR TITLE" label. Below the charts is a paragraph of placeholder text. Two men in suits are shown in the foreground, one pointing at the slide.</p>
<p>107</p>	<p>Talent A Close-up with Background+ PC Source) (CH3 Chromakey +CH7 Background+CH9 PIP)</p>	<p>Talent A Half-Body Chromakey with Virtual Scene+ Content</p>  <p>The image shows a business infographic slide titled "BUSINESS INFOGRAPHIC" with the subtitle "WRITE YOUR SUBTITLE HERE". The slide features two bar charts: one with green bars and a "50% YOUR TITLE" label, and another with blue bars and a "75% YOUR TITLE" label. Below the charts is a paragraph of placeholder text. A man in a plaid shirt is shown in the foreground, speaking, with a city skyline visible in the background.</p>
<p>108</p>	<p>Talent B Close-up with Background +PC Source (CH4 Chromakey+CH8 Background+CH9 PIP)</p>	<p>Talent B Half-Body Chromakey with Virtual Scene+ Content</p>  <p>The image shows a business infographic slide titled "BUSINESS INFOGRAPHIC" with the subtitle "WRITE YOUR SUBTITLE HERE". The slide features two bar charts: one with green bars and a "50% YOUR TITLE" label, and another with blue bars and a "75% YOUR TITLE" label. Below the charts is a paragraph of placeholder text. Two men in suits are shown in the foreground, one pointing at the slide, with a city skyline visible in the background.</p>

Chapter 9. How to Set the Chromakey, Save a Still to Memory, P-In-P and Still Functions

It is necessary to use the Chromakey and Still related functions of the SE-3200 for controlling the SE-3200 and for recalling the pre-saved virtual scenes directly by the TPC-700/TPC-700P. For the setting details and the operating steps, please refer to the **4.2 Keyer**, **4.3 Chroma**, **4.4 P-In-P** and the **Still** related paragraphs of the **4.9 Files** from the SE-3200 user manual.

Chapter 10 Introduction of the SE-3200 App Interface for the TPC-700/TPC-700P

The built-in SE-3200 control App for the Datavideo TPC-700/TPC-700P includes “Virtual Studio”, “AUX”, “Cross Point”, “Flex Source”, “PIP” and “Setup” options for users to control the SE-3200 remotely by the TPC-700/TPC-700P and an RJ-45 Ethernet cable. The main interface of the built-in SE-3200 control App for the TPC-700/TPC-700P is shown as following diagram.



10.1 Virtual Scenes

The Virtual Studio option allows users to recall the pre-saved No. 101 to No. 108 User Memos settings in the SE-3200 by the TPC-700/TPC-700P. There are 8 virtual scenes can be used by users including “Wide Angle with background”, “Close-up with background”, “Talent A close-up with background”, “Talent B close-up with background”, “Talent A + PC Source”, “Talent B + PC Source”, “Talent A close-up with background + PC Source”, “Talent B close-up with background + PC Source”. The final effects of those 8 different virtual scenes will be listed as following diagrams for users’ reference.

1. Wide Angle with background



2. Close-up with background



3. Talent A close-up with background



4. Talent B close-up with background



5. Talent A + PC Source

BUSINESS INFOGRAPHIC
WRITE YOUR SUBTITLE HERE

30

The infographic features a man in a plaid shirt speaking on the left. Behind him is a grid of 20 folders, 15 of which are green and 5 are grey. To the right is another grid of 20 folders, 15 of which are blue and 5 are grey. Below the blue folder grid is the text '75% YOUR TITLE' and a paragraph of text.

and brightest
in Fortune

75%
YOUR TITLE

Private equity has successfully attracted the best and brightest in corporate America, including top performers from Fortune 500 companies and elite strategy.

6. Talent B + PC Source



7. Talent A close-up with background + PC Source.

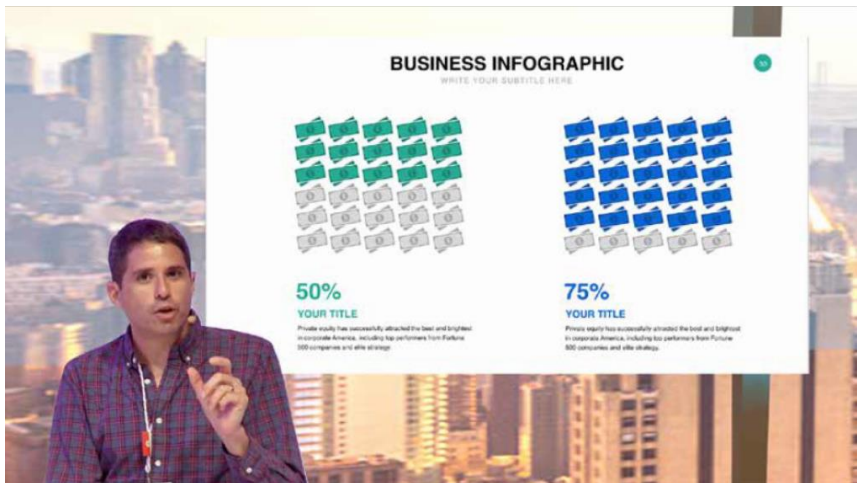

8. Talent B close-up with background + PC Source.



10.1.1 How to Recall the Pre-saved Virtual Scenes by the TPC-700/TPC-700P

Please recall the pre-saved virtual scenes by following steps.

1. Please make sure that all of the 8 virtual scenes are saved into the No. 101 to No.108 User Memos in advance. Moreover, please make sure that the SE-3200 main unit, the control panel, the TPC-700/TPC-700P and the router are connected correctly.
2. Please tap your desired virtual scene mode directly from the TPC-700/TPC-700P for recalling the corresponding virtual scene.

10.2 AUX

The Datavideo TPC-700/TPC-700P with the SE-3200 control software allows users to use the “AUX” function. The “AUX” function allows users to assign signal sources including CH1 to CH-12 input sources, PGM, PVW, CLN PGM, CLN PVW, PG + DSK, MULTIV, MULTIV2, STILL1, STILL2, FLEX SRC and FLEX SRC2 randomly to the output interfaces such as SDI1, SDI2, SDI3, SDI4, SDI5, SDI6, SDI7, SDI8, SDI9, SDI10, SDI11, SDI12, HDMI1, HDMI2 and HDMI3 to be the output sources. The main interface of the “AUX” option is shown as following diagram.



10.2.1 How to Use the “AUX” Function

Please follow following steps for using the “AUX” function.

1. Please select your desired output interface for outputting the signal source from the “OUTPUT” area.

2. Please select your desired signal source for output from the “SELECT” area.

3. Users can finish the signal assigning for the AUX function.



10.3 Cross Point

The “Cross Point” option allows users to adjust the sequence of the input signals by themselves without changing any input cables. For example, users can assign the signal source which is originally connected to input 2 to be the signal source of input 1. After the setting is finished, users can see that the source picture of the input 2 will be shown on the window of input 1. The main interface of the “Cross Point” is shown as following diagram.



10.3.1 How to Use the Cross Point Function

Please follow following steps for using the Cross Point Function.

1. Please select the input channel that you want to change the input signal source from the “INPUT” area.
2. Please select the channel No. that you want to use as the video input signal source from the “VIDEO XPT” area.
3. Please select the channel No. that you want to use as the audio input signal source from the “AUDIO XPT” area.

Note: If you want to turn off the output of the “VIDEO XPT” area, please tap the “OFF” button. If you want to use the embedded audio of the output video as the output audio source, please tap the “Follow” button.

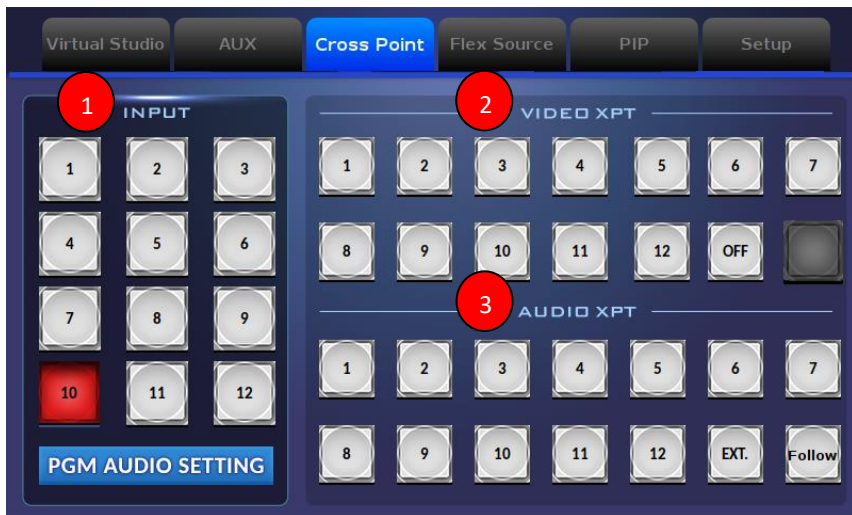

- **How to Enter the PGM AUDIO SETTING Interface**

1. Please tap the “PGM AUDIO SETTING” button.



2. Users can enter the “PGM AUDIO SETTING” interface to adjust the audio Gain and audio Delay.

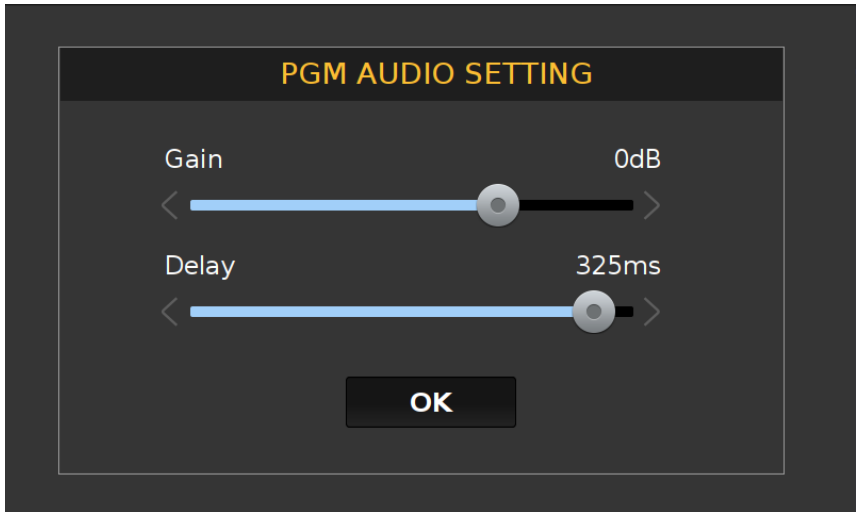

- **How to Use the “PGM AUDIO SETTING” Interface**

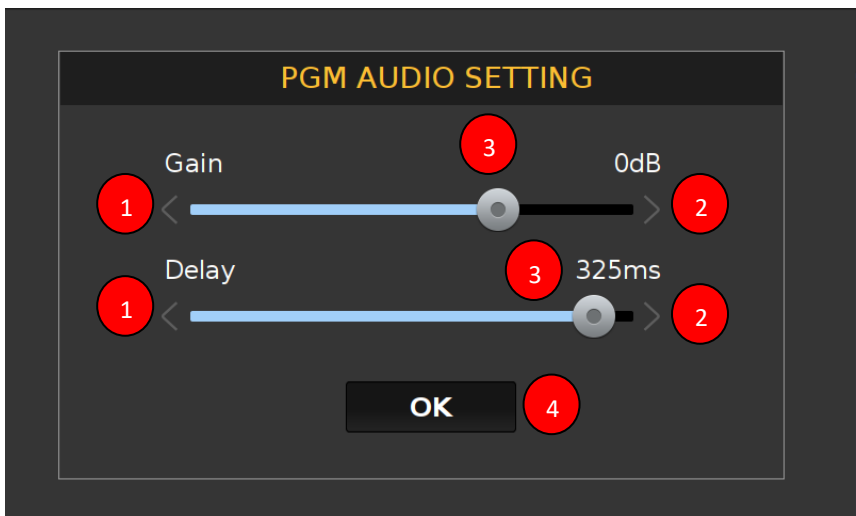

1. Please tap the No.1 arrow to decrease the Audio Gain and Audio Delay.
2. Please tap the No. 2 arrow to increase the Audio Gain and Audio Delay.
3. Please tap the No. 3 slider to increase or decrease the Audio Gain and Audio Delay by dragging the No.3 slider forward or backward.
4. Please tap the No. 4 “OK” button to make the setting effective and to go back to the previous screen.

10.4 Flex Source

The Flex Source function allows users to show videos in different sources simultaneously. Those videos can be shown in PROGRAM and PREVIEW simultaneously and can be set in different permutations.

The Flex Source output consists of a set of background picture and four sets of smaller source videos which are overlaid on the background picture. Those four smaller source videos will be displayed by their corresponding sub-picture windows.



The FLEX1 & FLEX2 buttons within the Flex Source interface allow users to recall an independent different Bgnd background picture respectively and four PIP sub-pictures which are shared by the FLEX 1 and FLEX 2 to form a variety of Flex Source screen combinations. **The two Bgnds for the Flex 1 and Flex 2 are independent respectively. However, all of the four PIP sub-pictures are shared by the Flex 1 and the Flex 2 and those four PIP sub-pictures are linked.** The main interface of the Flex Source option is shown as following diagram.



10.4.1 How to Use the Flex Source Function

Please follow following steps for using the Flex Source function.



How to Set the Background Picture for the Flex Source

1. At first, please tap the “Src Bgnd” button which is located at the “FLEX 1” area to select the background function for the Flex Source.

2. Please tap the source signal channel that you want to use to be the Src background picture from the “SELECT” area. (The source signal channels include BLK, 1~12, STILL 1 & STILL 2, MATTE and BARS).

How to Set the Sub-Picture Source Signal for the P-In-P of Flex Source

1. At first, please tap the “Src 1”, “Src 2”, “Src 3” or “Src 4” button within the “FLEX 1” area.
2. Please tap the source signal channel that you want to use to be the Src 1, Src 2, Src 3 or Src 4 sub-signal from the “SELECT” area.
3. Please move the white cross box by your finger to determine the sub-picture placement for the Src 1, Src 2, Src 3 or Src 4.
4. Please tap the “X”, “Y” or “SIZE” and then those characters will become orange.
5. Please tap the left or the right arrow button to adjust the scale of the “X”, “Y” or “SIZE”.

Note: When the X, Y or Size character become orange, users can tap that character once again and then the character will become light blue. When the character becomes light blue, users are forbidden to adjust the scale of X, Y or SIZE.



The ON/OFF button allows users to open or to close the display of the Flex Source Src1 to Src 4.

How to Use the FLEX 1 & FLEX 2 Buttons

The FLEX 1 & FLEX 2 buttons allow users to recall an independent Bgnd background pictures for the FLEX 1 and FLEX 2 respectively and four PIP sub-pictures which are shared by the FLEX 1 and FLEX 2 to form a variety of Flex Source screen combinations. Please refer to following examples for realizing the relation between the FLEX 1 & FLEX 2 screen combinations.

Screen Combination No.	The Screen for FLEX 1	The Screen for FLEX 2
1	Flex 1 : Bgnd x 1, PIP x 2	Flex 2 : Different Bgnd x 1, PIP x 2

2	Flex 1 : Bgnd x 1, PIP x 3	Flex 2 : Different Bgnd x 1, PIP x 1
3	Flex 1 : Bgnd x 1, PIP x 4	Flex 2 : Different Bgnd x 1, PIP x 0

Users can know from the above-mentioned examples that the FLEX 1 mode and the FLEX 2 mode can display different Bgnd background screen respectively. However, the four PIP screens must be shared by the FLEX 1 and FLEX 2 together. It means that if all of the four PIP screens are opened, the same PIP screens will be shown on both FLEX 1 and FLEX 2.

Note: If users do not want to show the same PIP screens on both FLEX 1 and

FLEX 2, please remember to use the ON/OFF button  to hide the repetitive PIP screens.

10.5 PIP

The main interface of the PIP option allows users to set the PIP related functions. Please refer to following steps for setting the PIP function.

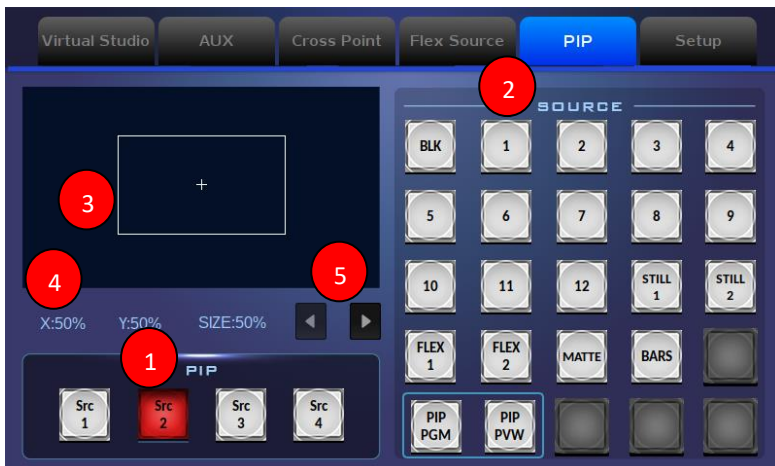

How to Set the Sub-Picture Source Signal for the PIP

1. At first, please tap the “Src 1”, “Src 2”, “Src 3” or “Src 4” button from the PIP area.
2. Please tap the source signal channel that you want to use to be the Src 1, Src 2, Src 3 or Src 4 sub-signal from the “SOURCE” area. (The source signal channels include BLK, 1~12, STILL 1 & STILL 2, FLEX1 & FLEX2, MATTE and BARS).
3. Please move the white cross box by your finger to determine the sub-picture placement for the Src 1, Src 2, Src 3 or Src 4.
4. Please tap the “X”, “Y” or “SIZE” and then those characters will become orange.
5. Please tap the left or the right arrow button to adjust the scale of the “X”, “Y” or “SIZE”.

Note: When the X, Y or Size character become orange, users can tap that character once again and then the character will become light blue. When the character becomes light blue, users are forbidden to adjust the scale of X, Y or SIZE.

10.6 Setup

The built-in SE-3200 control interface of the TPC-700/TPC-700P allows users to set many parameters including Language, Connect, Screen Saver, FW Version and Model. The main interface for the Setup is shown as the following diagram.

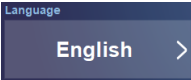

1. Language: This button allows users to select three different language interfaces including Traditional Chinese, English and Simplified Chinese.

- Please tap this “Language” button .

- After that, users can select their desired language. If the “Save” button is pressed, it will go back to previous page after the setting is saved. If the “Cancel” button is pressed, it will go back to previous page directly.

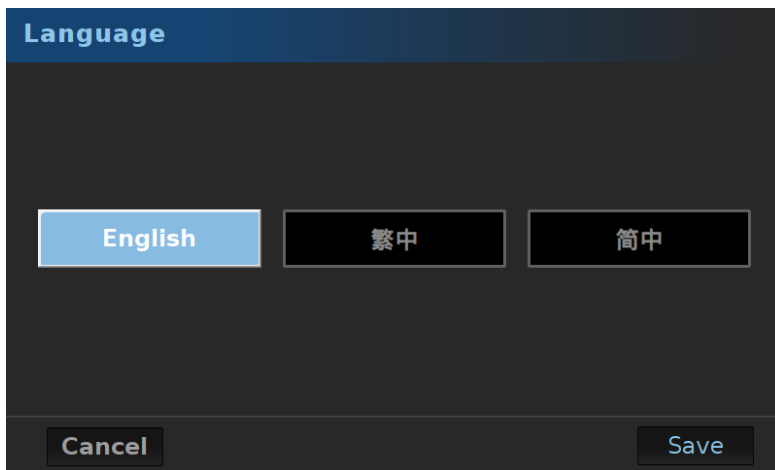

2. Connect: Press this button for entering the “Connect” interface.

- Please press the “Scan” button for scanning the connected SE-3200.
- After the SE-3200 is found, Please click the “IP Select” drop-down menu to select the IP address of the connected device.
- After that, please click the “Connect” button to connect the TPC-700/TPC-700P and the SE-3200. If the “Disconnect” button is pressed during the TPC-700/TPC-700P and the SE-3200 are connected, the connection will be cancelled. If the “Cancel” button is pressed, it will go back to the “Setup” interface.

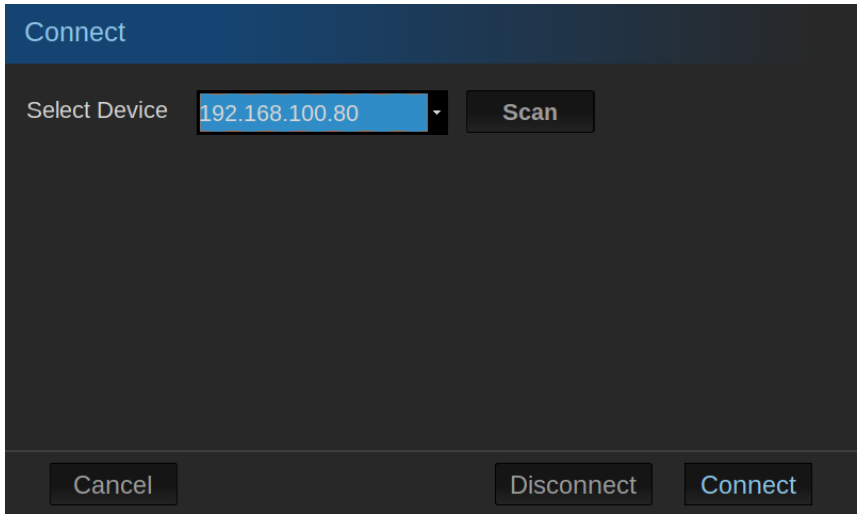

3. Screen Saver: Please press this button to enter the “Screen Saver” main interface which allows you to adjust the screen saver wait time within 0(OFF) to 10 minutes range by using a slider. After the adjustment is finished, please click the “Save” button for applying the setting. Once it reaches the preset time length, the screen saver screen will be shown to save the power consumption and to extend the lifetime of the monitor.

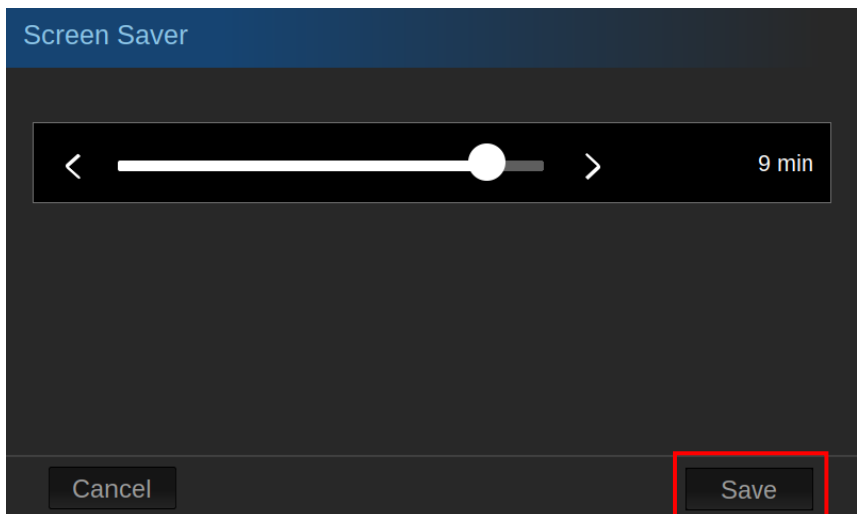

The logo for 'datavideo' is centered on a black rectangular background. The text 'datavideo' is written in a white, lowercase, sans-serif font. The 'a' and 'o' are stylized with a circular shape around them.

4. FW Version: This column will show current version number of the SE-3200 App which is installed in the TPC-700/TPC-700P controller.

5. Model: This column will show the product model which is connected by this App, which is the SE-3200.

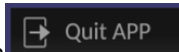

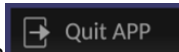
6. Quit App: Please press this button  to quit the SE-3200 App and then go back to the main screen of the TPC-700/TPC-700P.

Chapter 11. Introduction of the Built-in VGB-2000 App Interface for the TPC-700/TPC-700P



When the User Memory of the SE-1200MU is set, users can use the TPC-700 Touch Panel Controller to apply their needed default mode directly.

11.1 Main Interface of the TPC-700 App-Single & Dual

Please see following diagram for the Single & Dual Camera interface for the TPC-700 App.

- **Single Camera**



The main interface of the single camera is shown in the following diagram, it provides different mode buttons including “Close UP+ Interactive Pen Mark”, “Close UP+ Interactive Pen Mark+ Logo”, “Interactive Pen Mark + Logo”, “Interactive Pen Mark” and “Close UP with Chromakey + Sliders”. Moreover, you can choose Traditional Chinese, Simplified Chinese or English from the

language drop-down menu . Click the  button allows you to quit the VGB-2000 App and then go back to the main interface of the TPC-700/TPC-700P.



● Dual Camera

The main interface of the single camera is shown in the following diagram, it provides different mode buttons including “Close UP+ Interactive Pen Mark”, “Close UP+ Interactive Pen Mark+ Logo”, “Interactive Pen Mark + Logo”, “Interactive Pen Mark”, “Close Up with Chromakey”, “Wide Angle with Chromakey” and “Wide Angle with Chromakey + Interactive Pen Mark”. Moreover, you can choose Traditional Chinese, Simplified Chinese or English

from the language drop-down menu . Click the  button allows you to quit the VGB-2000 App and then go back to the main interface of the TPC-700/TPC-700P.

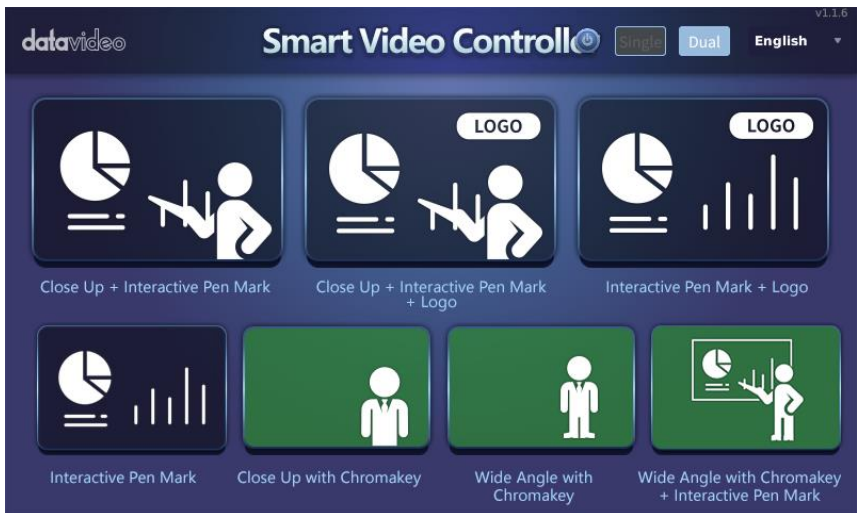

11.2 Operation Steps for the VGB-2000 App for TPC-700/TPC-700P

The Datavideo TPC-700 Touch Panel Controller allows users to tap the option which is shown on the screen for applying the pre-saved effects that are set by the SE-1200MU. This allows users to use more simple way for applying their desired effects when shooting the teaching videos. For the operation of the TPC-700, please see following steps.

Step 1. At first, please use a D-Sub 9 pin to RJ-45 adapter cable to connect from the RS-232 interface which is on the rear panel of the VGB-2000 to the RJ-45 interface of the TPC-700.

Step 2. After the preset settings of the SE-1200MU are set, users can apply their desired effects by tapping the option which is shown on the TPC-700 screen directly.

- Single Camera Effects
- Close Up+ Interactive Pen Mark



- Close Up + Interactive Pen Mark + Logo



datavideo

Varvid Produces and Streams Facebook Careers Panel Using Datavideo Products

- Varvid is a Seattle based, growing live event and streaming production company whose primary business is serving the needs of corporate clients. Varvid started when CEO and founder Aaron Booker used his IT expertise to help filmmaking friends webcast a local rock concert in Bellingham, WA in 2002. Since then they have served clients such as Wizards of the Coast, BMW, NewBay, as well as provide media production services internationally for events in the accounting, entertainment, eSports, healthcare, IT, and non-profit industries.
- Recently, Varvid was contacted by Facebook Seattle to help them produce and stream a live interactive discussion panel that shared real-world experiences of what it is like working for the tech giant Facebook as a recruiting tool. A panel of four team members from various job functions within Facebook's software development team shared their experience, culture and real-world experiences of what it is like working for Facebook and used chat to answer questions from prospective employees.

- Interactive Pen Mark + Logo



datavideo

Varvid Produces and Streams Facebook Careers Panel Using Datavideo Products

- Varvid is a Seattle based, growing live event and streaming production company whose primary business is serving the needs of corporate clients. Varvid started when CEO and founder Aaron Booker used his IT expertise to help filmmaking friends webcast a local rock concert in Bellingham, WA in 2002. Since then, they have served clients such as Wizards of the Coast, BMW, NewBay, as well as provide media production services internationally for events in the accounting, entertainment, eSports, healthcare, IT, and non-profit industries.
- Recently, Varvid was contacted by Facebook Seattle to help them produce and stream a live interactive discussion panel that shared real-world experiences of what it is like working for the tech giant Facebook as a recruiting tool. A panel of four team members from various job functions within Facebook's software development team shared their experience, culture and real-world experiences of what it is like working for Facebook and used chat to answer questions from prospective employees.

➤ Interactive Pen Mark



Varvid Produces and Streams Facebook Careers Panel Using Datavideo Products

- Varvid is a Seattle based, growing live event and streaming production company whose primary business is serving the needs of corporate clients. Varvid started when CEO and founder Aaron Booker used his IT expertise to help filmmaking friends webcast a local rock concert in Bellingham, WA in 2002. Since then, they have served clients such as Wizards of the Coast, BMW, NewBay, as well as provide media production services internationally for events in the accounting, entertainment, eSports, healthcare, IT, and non-profit industries.
- Recently, Varvid was contacted by Facebook Seattle to help them produce and stream a live interactive discussion panel that shared real-world experiences of what it is like working for the tech giant Facebook as a recruiting tool. A panel of four team members from various job functions within Facebook's software development team shared their experience, culture and real-world experiences of what it is like working for Facebook and used chat to answer questions from prospective employees.

➤ Close Up with Chromakey + Slides



- Dual Camera Effects
- Close Up + Interactive Pen Mark



Varvid Produces and Streams Facebook Careers Panel Using Datavideo Products

- Varvid is a Seattle based, growing live event and streaming production company whose primary business is serving the needs of corporate clients. Varvid started when CEO and founder Aaron Booker used his IT expertise to help filmmaking friends webcast a local rock concert in Bellingham, WA in 2002. Since then they have served clients such as Wizards of the Coast, BMW, NewBay, as well as provide media production services internationally for events in the gaming, entertainment, eSports, healthcare, IT, and non-profit industries.

Recently, Varvid was contacted by Facebook Seattle to help them produce and stream a live interactive discussion panel that shared real-world experiences of what it is like working for the tech giant Facebook as a recruiting panel of four team members from various job functions within Facebook's software development team shared their experience, culture and real-world experiences of what it is like working for Facebook and used chat to answer questions from prospective employees.

- Close Up + Interactive Pen Mark + Logo

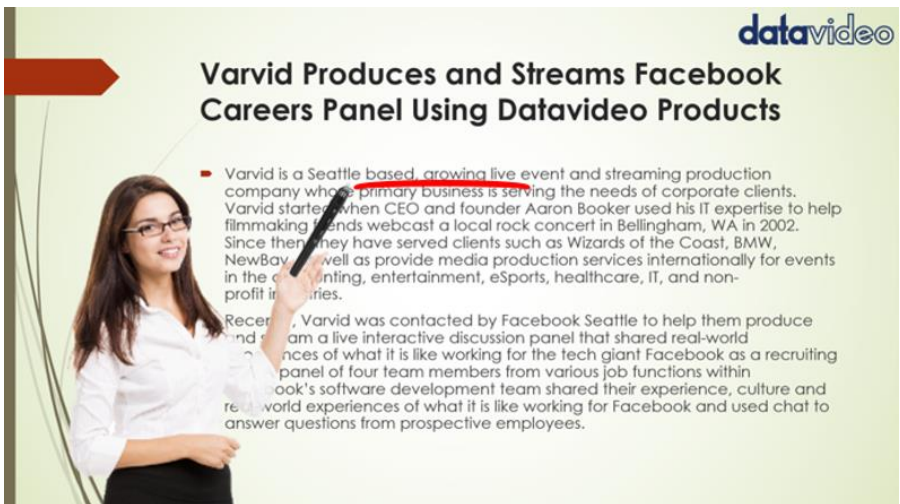



Varvid Produces and Streams Facebook Careers Panel Using Datavideo Products

- Varvid is a Seattle based, growing live event and streaming production company whose primary business is serving the needs of corporate clients. Varvid started when CEO and founder Aaron Booker used his IT expertise to help filmmaking friends webcast a local rock concert in Bellingham, WA in 2002. Since then they have served clients such as Wizards of the Coast, BMW, NewBay, as well as provide media production services internationally for events in the gaming, entertainment, eSports, healthcare, IT, and non-profit industries.

Recently, Varvid was contacted by Facebook Seattle to help them produce and stream a live interactive discussion panel that shared real-world experiences of what it is like working for the tech giant Facebook as a recruiting panel of four team members from various job functions within Facebook's software development team shared their experience, culture and real-world experiences of what it is like working for Facebook and used chat to answer questions from prospective employees.

➤ Interactive Pen Mark + Logo



Varvid Produces and Streams Facebook Careers Panel Using Datavideo Products

- Varvid is a Seattle based, growing live event and streaming production company whose primary business is serving the needs of corporate clients. Varvid started when CEO and founder Aaron Booker used his IT expertise to help filmmaking friends webcast a local rock concert in Bellingham, WA in 2002. Since then, they have served clients such as Wizards of the Coast, BMW, NewBay, as well as provide media production services internationally for events in the accounting, entertainment, eSports, healthcare, IT, and non-profit industries.
- Recently, Varvid was contacted by Facebook Seattle to help them produce and stream a live interactive discussion panel that shared real-world experiences of what it is like working for the tech giant Facebook as a recruiting tool. A panel of four team members from various job functions within Facebook's software development team shared their experience, culture and real-world experiences of what it is like working for Facebook and used chat to answer questions from prospective employees.

➤ Interactive Pen Mark

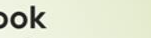

Varvid Produces and Streams Facebook Careers Panel Using Datavideo Products

- Varvid is a Seattle based, growing live event and streaming production company whose primary business is serving the needs of corporate clients. Varvid started when CEO and founder Aaron Booker used his IT expertise to help filmmaking friends webcast a local rock concert in Bellingham, WA in 2002. Since then, they have served clients such as Wizards of the Coast, BMW, NewBay, as well as provide media production services internationally for events in the accounting, entertainment, eSports, healthcare, IT, and non-profit industries.
- Recently, Varvid was contacted by Facebook Seattle to help them produce and stream a live interactive discussion panel that shared real-world experiences of what it is like working for the tech giant Facebook as a recruiting tool. A panel of four team members from various job functions within Facebook's software development team shared their experience, culture and real-world experiences of what it is like working for Facebook and used chat to answer questions from prospective employees.

➤ Close Up with Chromakey



➤ Wide Angle with Chromakey



➤ Wide Angle with Chromakey + Interactive Pen Mark



Chapter 12 Interface Introduction of the TPC-700/TPC-700P Built-in DVK-400 App

The Datavideo TPC-700/TPC-700P built-in DVK-400 app includes “Home”, “Input/Output”, Chromakey”, “Lumakey” “Window”, “User Memory”, “Connect” and “Setup” options for users to control the DVK-400 remotely by using the TPC-700/TPC-700P and the RJ-45 Ethernet cable connection. The main interface of the TPC-700/TPC-700P built-in DVK-400 app is shown in the following diagram.

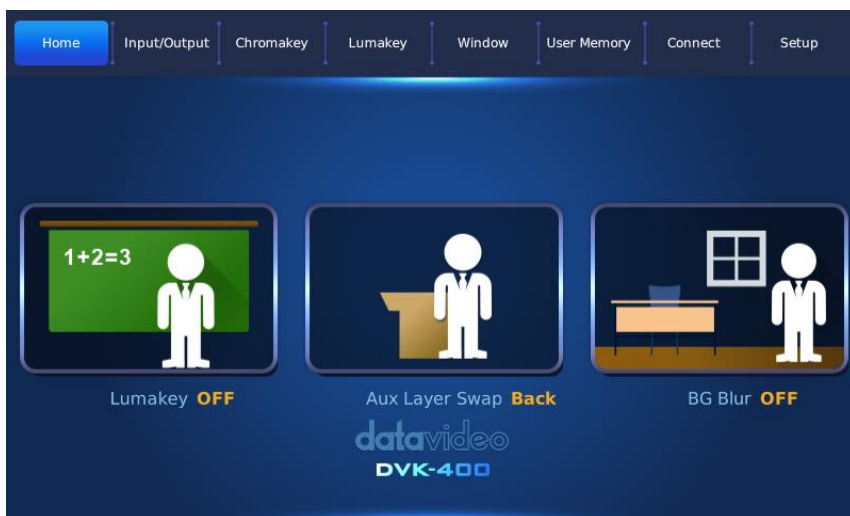

12.1 Home

After related parameters in the DVK-400 PC App are set in advance, the “Home” option provides three buttons including “Lumakey ON/OFF”, “AUX Layer Swap Front/Back” and “BG Blur ON/OFF” for you to control the related functions.

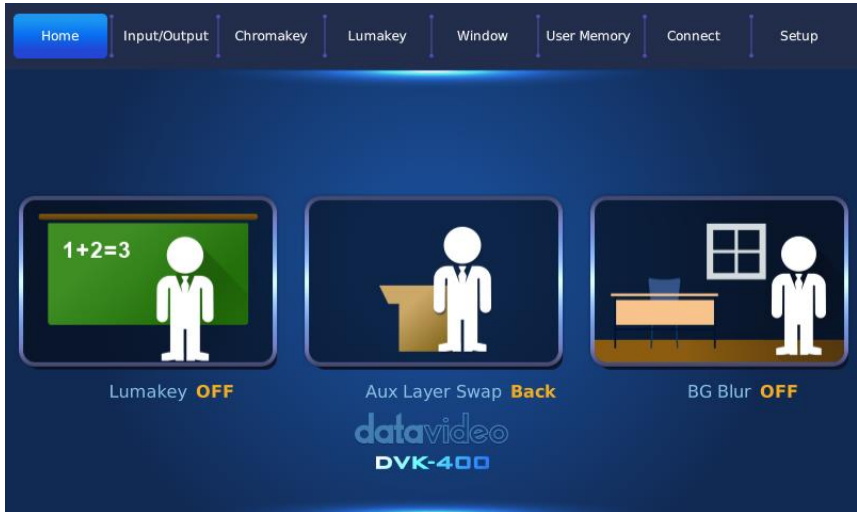

- Lumakey ON/OFF: Press this button allows you to switch between the “Lumakey ON” and “Lumakey OFF”.
 - Lumakey ON: This allows you to apply the Lumakey effect.
 - Lumakey OFF: If this button is pressed, the Lumakey effect will not be applied.
- AUX Layer Swap Front/Back: Press this button to switch between “AUX Layer Swap Front” and “AUX Layer Swap Back”.
 - AUX Layer Swap Front: If the “AUX Layer Swap Front” is set, the Chromakey layer will be behind the AUX Lumakey layer.
 - AUX Layer Swap Back: If the “AUX Layer Swap Back” is set, the Chromakey layer will be in front of the AUX Lumakey Layer.
- BG Blur ON/OFF: Press this key allows you to switch between the “BG Blur ON” and “BG Blur OFF”.

- If the “BG Blur ON” is set, it will turn on the BG Blur function.
- If the “BG Blur OFF” is set, it will turn off the BG Blur function.

12.2 Input/Output

After related parameters in the DVK-400 PC App are set in advance, the Input/Output option allows you to select the foreground input source and the output or preview screen type. The main interface of the Input/Output option is shown in the following diagram.



- **FG INPUT SOURCE:** This option allows you to select the SDI or HDMI input to be the foreground input source.
- **OUTPUT:** This option allows you to select different signal sources for the PGM (SDI), PGM (HDMI) and PVW (SDI/HDMI) interfaces.
 - **PGM (SDI):** This option allows you to select the output image type for the “PGM (SDI)” interface.
 - **PGM (HDMI):** This option allows you to select the output image type for the PGM (HDMI) interface.
 - **PVW (SDI/HDMI):** This option allows you to select the output image type for the PVW (SDI) (HDMI) interface.

The output image sources are shown in the following diagram.

- FG: The input source of the foreground camera.
- BG: The input source of the background camera.
- Matte: Mask.
- PFG: Processed Foreground Image.
- Comp: Composite image for foreground and background images
- Mirror: Press this button can flip the output image to the left side or the right side.
- Lock: Press this button can lock the output interface and turn off the image source selection function.

12.3 Chromakey

After related parameters in the DVK-400 PC App are set in advance, the Chromakey option allows you to turn on or turn off the Chromakey function and to adjust the Black Level and Spill Suppression function. The main interface for the Chromakey function is shown in the following diagram.

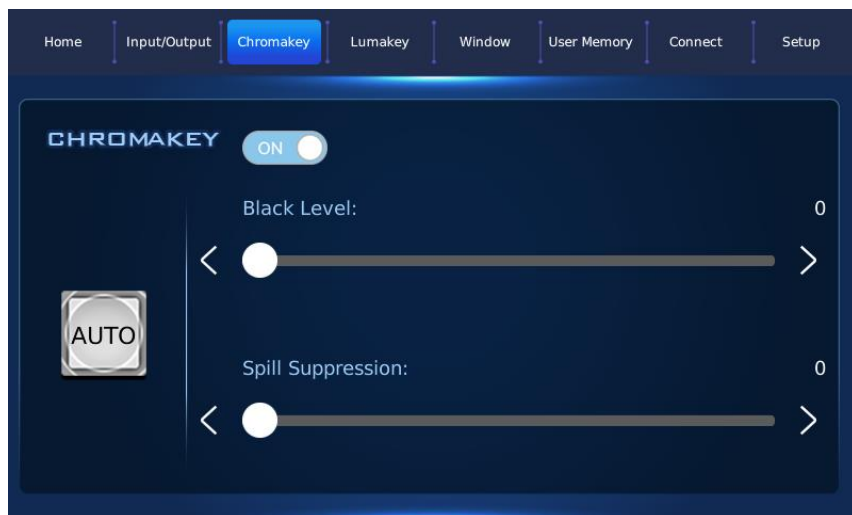

- Chromakey ON/OFF: Click this toggle switch to turn on or turn off the Chromakey function.
- Black Level: The Black Level value can be adjusted directly by using this slider. The default value of the Black Level is 200. If this value is increased, black objects or hair will be more obvious. You can adjust the “Black Level” by using the slider or the left or right arrow button.
- Spill suppression removes the green or blue color reflected onto the foreground subject from the screen. Setting the spill suppression to zero removes the green or blue color component and setting the spill suppression to 500 adds the green or blue color component. A good spill suppression range is 400 – 700. The default value is 500. You can use the slider or left and right arrow keys to adjust the **Spill Suppression**.

12.4 Lumakey

After related parameters in the DVK-400 PC App are set in advance, the Lumakey option allows you to turn on or turn off the “Lumakey” function, to select the Key mode of the Lumakey and to adjust the “Cut Off” level and “Layer Swap” time. The main interface of the Lumakey option is shown in the following diagram.

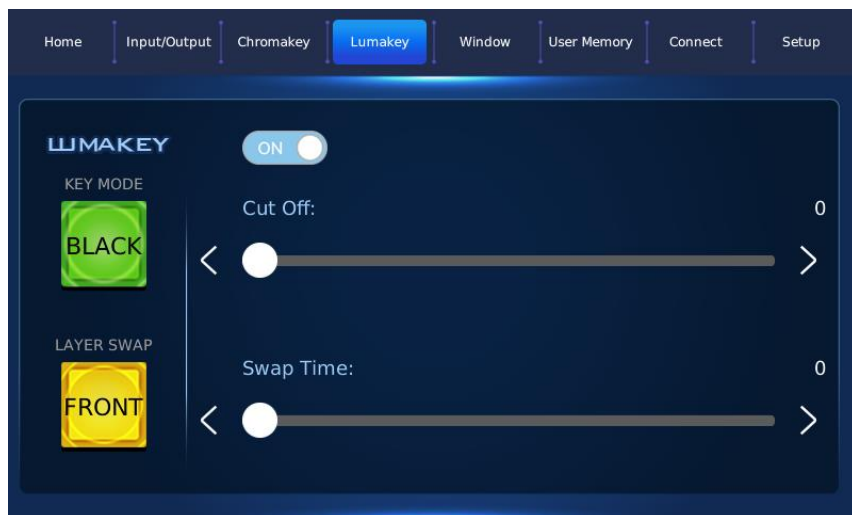

- Lumakey ON/OFF toggle switch: Click this toggle switch to turn on or turn off the Lumakey function.
- KEY MODE: There are two Modes including Black and White Modes. Click this button once to switch between the Black and White. Select “Black” if the foreground is shot against a black background and “White” if the foreground is shot against a white background.
- LAYER SWAP: There are two modes including “Front” and “Back”. Click this button once to switch between “Front” and “Back”. Enable “Layer Swap” to place the Chromakey layer on top of the AUX Lumakey layer and vice versa.
- “Cut Off”: The default “Cut Off” value is 0. Increase this value gradually until either of the black and white backgrounds of the AUX source is 100% removed. For a black background, set Cut Off to 10-20% of its maximum value. For a white background, set Cut Off to 80-90% of its maximum value. You can use the slider or the left and right arrow buttons to adjust the “Cut Off” option.
- Swap Time: Swap time sets the transition time during layer swap. For example, if the swap time is set to 20, multiply this number by 0.1 to derive the transition time of 2 seconds. You can use the slider or the left and right arrow buttons to adjust the “Swap Time” option.

12.5 Window

After related parameters in the DVK-400 PC App are set in advance, the Window option allows you to turn on or turn off the “Garbage Window” and “Holdout Window” ON/OFF buttons. Moreover, it also allows you to adjust the “Top”, “Bottom”, “Left” and “Right” range of edges and the values for the soft-edge effect. The main interface of the Window option is shown in the following diagram.



12.6 USER MEMORY

After related parameters in the DVK-400 PC App are set in advance, the User Memory option allows you to save or load up to 8 setting values.

- How to save the User Memory setting:
 - At first, please make sure that your desired settings are set in the DVK-400 PC App in advance.
 - Please select one User Memory position from USER 1 to USER 8 that you want to save the settings.
 - And then please press the “Save” button for saving the settings.
- How to load the User Memory Settings:
 - Please select one User Memory position that you want to load the settings from the USER 1 to USER 8.
 - And then please press the “Load” button for loading the settings.

The main interface of the User Memory is shown in the following diagram.



12.7 Connect

After related parameters in the DVK-400 PC App are set in advance, the “Connect” option allows you to set “Interface”, “Scan in Network” or “Select Device” options. The main interface of the “Connect” option is shown in the following diagram.

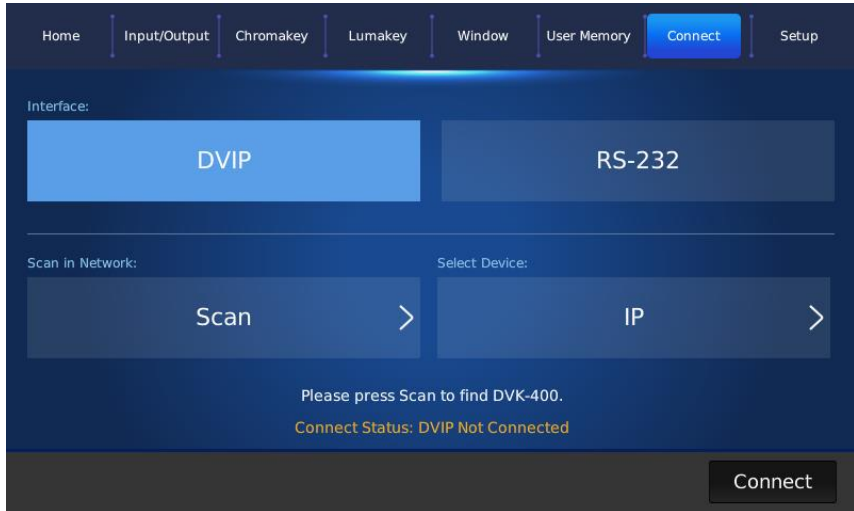

Interface: There are two interfaces including DVIP and RS-232. Please click the DVIP or the RS-232 button for selecting. Please select the interface according to the connection interface which is selected in the DVK-400 PC App. The selection in this section must be the same with the connection interface which is selected in the DVK-400 PC App.

Scan in Network: If the DVIP interface is selected for connection, press this button allows you to search the DVK-400 which is connected by the TPC-700/TPC-700P automatically.

Select Device: This option will show the IP address of the connected DVK-400.

Connect: When the interface is selected and the DVK-400 is found, please click this “Connect” button to connect the TPC-700/TPC-700P with the DVK-400.

12.8 Setup

After related parameters in the DVK-400 PC App are set in advance, the “Setup” option allows you to set various parameters including “Output Resolution”, “HDMI Output Format”, “Language”, “FW Version”, “FPGA Version”, “Bootloader Version” and “Screen Saver”. The main interface of the “Setup” option is shown in the following diagram.

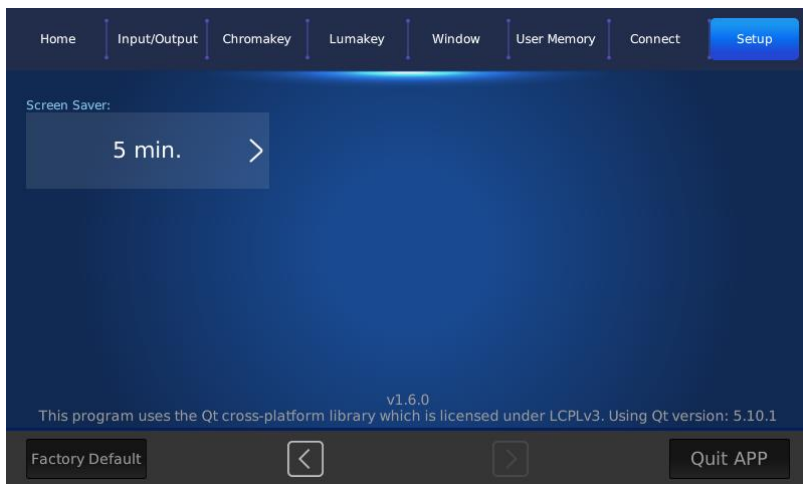
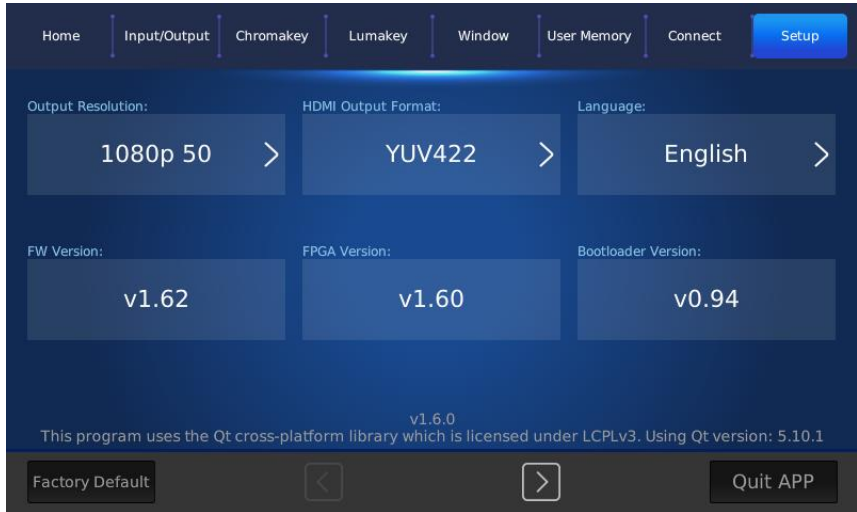

- Output Resolution: Please press this button to select your desired output resolution. After that, please press the “Save” button to select your desired DVK-400 output resolution.



- HDMI Output Format: Please press this button to select your desired HDMI output format from the three output formats which are shown in the following diagram. After the format is selected, please press the “Save” button to confirm the selected HDMI output format.

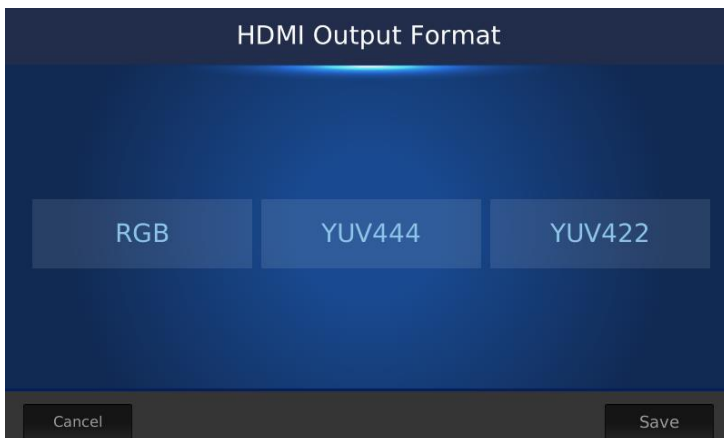

- Language: Please press this button to select your desired language from three languages including Traditional Chinese, English and Simplified Chinese. After your desired language is selected, please press the “Save” button to confirm the selected language.

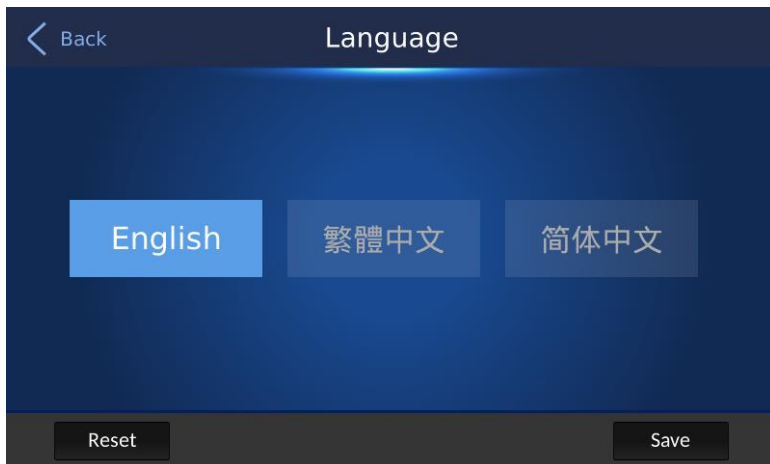

- FW Version: This column will show the software version of the main board.
- FPGA Version: This column will show the FPGA Version.
- Bootloader Version: This column will show the Bootloader Version.

Note: The FW Version, FPGA Version and Bootloader Version will be shown only when the TPC-700 or the TPC-700P is connected to the DVK-400 successfully.

- Factory Default: After the “Factory Default” button is pressed, the Factory Default confirmation dialogue box will be shown. After the “Reset” button is pressed, you can reset the DVK-400 App which is installed in the TPC-700/TPC-700P to its factory default settings.

Factory Default



Do you want to reset factory default?

Cancel

Reset

FACTORY RESET



Reset Successfully

OK

- Quit APP: After the “Quit APP” button is pressed, the “Quit APP” dialogue box will be shown. After the “OK” button is pressed, the DVK-400 App will be closed.

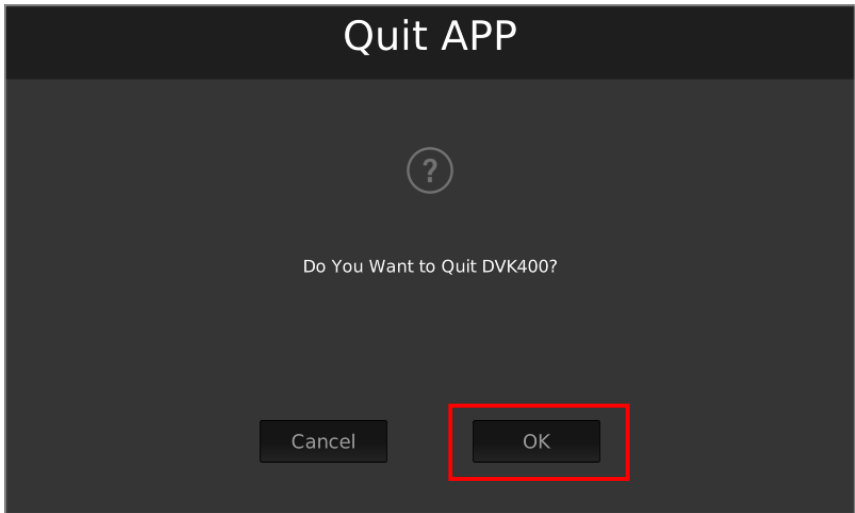

- Screen Saver: After entering the “Setup” page, please press the “right arrow” button  to show the “Screen Saver” option which is shown in the following diagram.

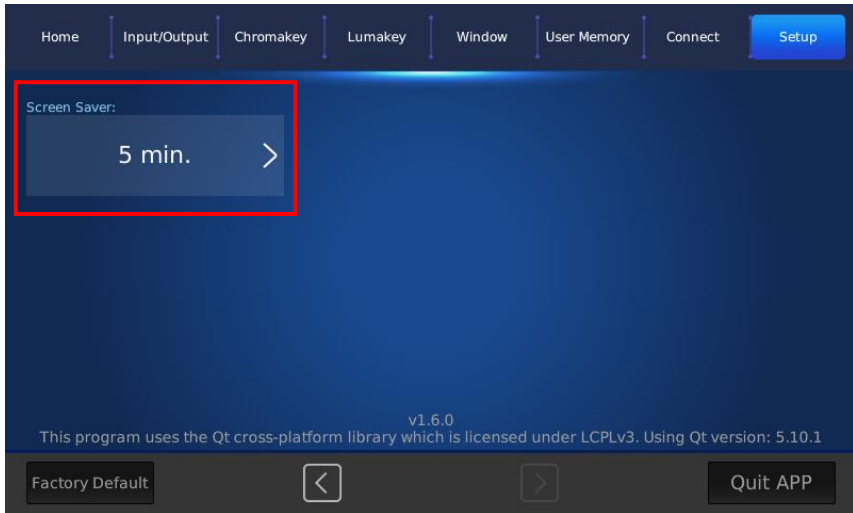

After pressing the “Screen Saver” button, you can see the “Screen Saver” adjustment slider for you to adjust the “Screen Saver” wait time from 0(OFF) to 10 minutes which is shown in the following diagram. After the adjustment is finished, please press the “Save” button for applying the setting.

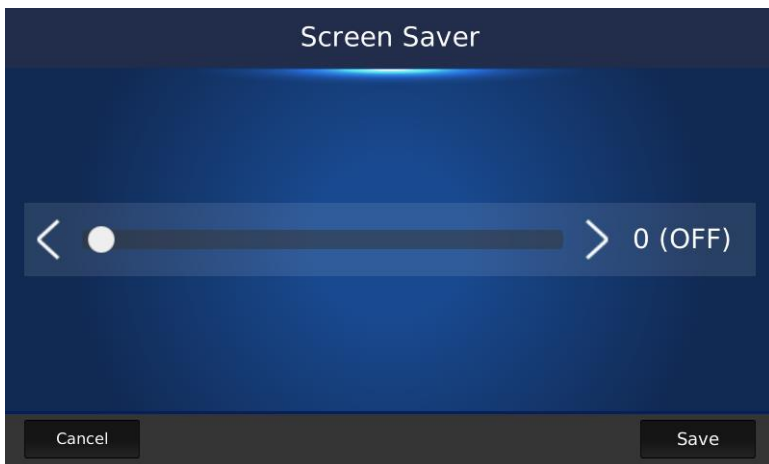

Chapter 13 Interface Introduction of the TPC-700/TPC-700P Built-in ZR-1 App

The Datavideo TPC-700/TPC-700P built-in ZR-1 app is a powerful tool for you to control the Datavideo iCAST 10 NDI 5-Channel All-in-one Streaming Switcher web UI functions within one app. Moreover, the ZR-1 app allows you to control up to 3 cameras at the same time. Before controlling the Datavideo iCAST 10 NDI, what you need to do is to finish the connections and settings for all facilities.

13.1 Connections

Before controlling the iCAST 10 NDI by the ZR-1 app, please connect your TPC-700/TPC-700P to your iCAST 10 NDI according to the following diagram in advance.

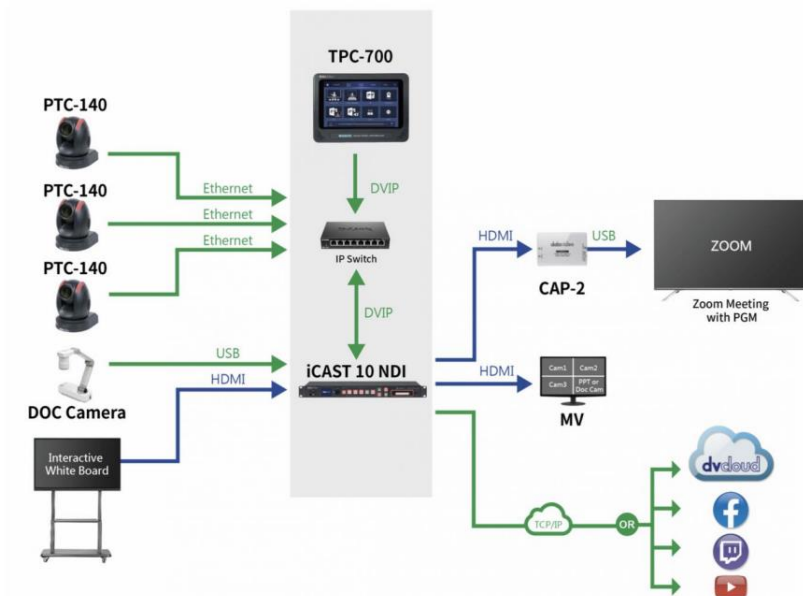

After the connection is done, please make sure that your iCAST 10 NDI, PTZ cameras and TPC-700 or TPC-700P are set in the same IP range for controlling your iCAST 10 NDI by the TPC-700 or TPC-700P. In the following section, we will introduce the user interface of the ZR-1 app for you.

13.2 ZR-1 Main Interface

After all connections are done, please press the ZR-1 app icon from your TPC-700 or TPC-700P to enter its main interface. This chapter will take the ZR-1 app version 1.0.9 as an example. There are two modes in the ZR-1 app user interface including the “3 cams” mode and the “2 cams” mode. Please follow the steps below to enter the main interface.



1. Please tap the ZR-1 app icon.
2. Please press the “Admin” button. After that, please press the “Apply” button.

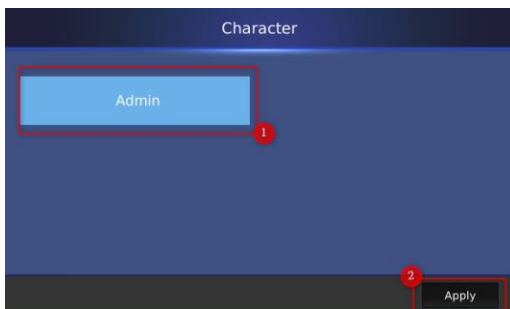

3. You will see a keypad, please enter the default administration password.

Default Password: admin

After that, please press the “OK” button to enter the ZR-1 app interface.

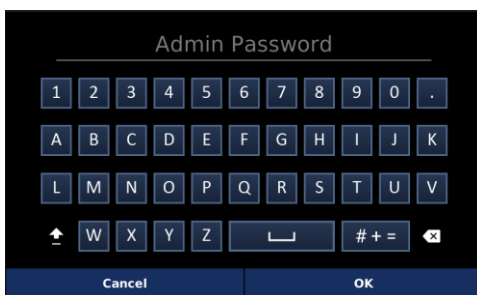

4. The ZR-1 app will search the connected DVIP devices.

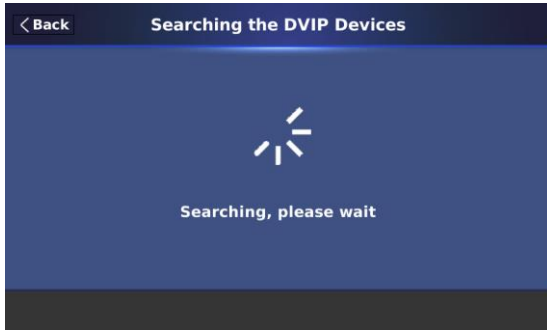

5. After the connected devices are found, the main interface will be shown.

You can tap the button  which is located at the top-right side of the screen to select "2 cams" or "3 cams" main interface.

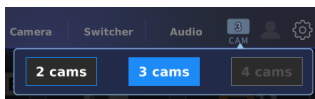

13.2.1 3 cams Interface-Home

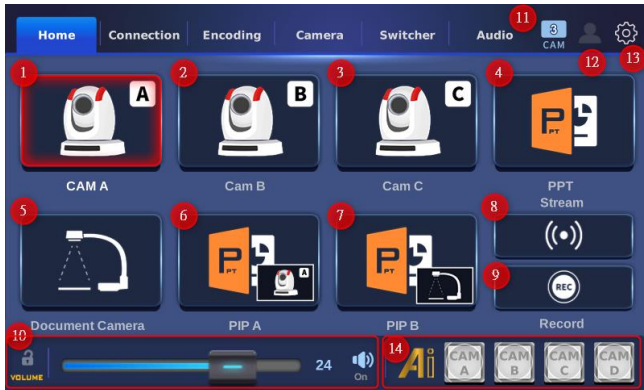

1. CAM A : The “CAM A” button allows you to show the image source which is shot by the camera connected to the HDMI input 1 of the iCAST 10 NDI to the PGM external monitor.

2. CAM B: The “CAM B” button allows you to show the image source which is shot by the camera connected to the HDMI input 2 of the iCAST 10 NDI to the PGM external monitor.

3. CAM C: The “CAM C” button allows you to show the image source which is shot by the camera connected to the HDMI input 3 of the iCAST 10 NDI to the PGM external monitor.



4. PPT: Press this button to show the PowerPoint image source from the interactive white board or laptop to the PGM external monitor.

5. Document Camera: Press this button to show the image source of the document camera to the PGM external monitor.

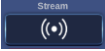

6. PIP A: Press this button to show the PowerPoint image source on the PGM external monitor and to show the image source of the camera A in the inserted sub window.

7. PIP B: Press this button to show the PowerPoint image source on the PGM external monitor and to show the image source of the document camera in the inserted sub window.

8. Stream: Once the video encoding and streaming related parameters are set in the “Encoding→Encoder” and “Encoding→Stream” in advance, you can press this “Stream” button to stream up to 12 video sources including CH1, CH2, CH3, CH4, CH5 and PGM for the Main and Sub encoders to different live-streaming platforms simultaneously. If the video streaming is in progress, this button will be shown in red . If the video is not streamed, this button will be shown in white .

9. Record: Once the video encoding and recording related parameters are set in the “Encoding→Encoder” and “Encoding→Record” in advance, you can press this “Record” button to record up to 12 video sources including CH1, CH2, CH3, CH4, CH5 and PGM for the Main and Sub encoders simultaneously. If the video recording is in progress, this button will be shown in red . If the video is not recorded, this button will be shown in white .

10. Volume control slider: This slider allows you to adjust the volume of the PGM output.

- Press the speaker icon  to turn on or to mute the PGM volume.
- Press the “Volume Lock” icon  to switch between “Lock” and “Unlock”. Once it is locked, the volume can not be adjusted.

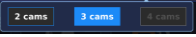
11. 2 cams & 3 cams modes switch buttons: Please press this button  to select the “2 cams” mode or the “3 cams” mode . The “4 cams” mode is **currently unavailable**.

12. Account & Password login button: This button allows you to login into up to 4 different accounts including 1 administration account and 3 user accounts by entering “User Name” and “Password” respectively. The example is shown in the following diagram.

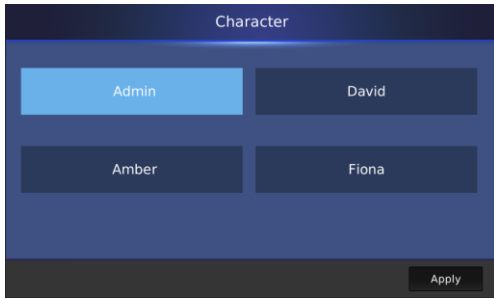

Before using this function, you have to make sure that your account and password are set in advance in “Account & Password→Add New User”. You can press the gear icon  which is located on the top-right side of the screen to enter the “settings” page.

13. Gear icon: Please press this gear icon  to enter the “Settings” page. The “Settings” page provides you to set various options including “Language”, “Account & Password”, “Factory Default”, “Auto DVIP Scan” and “Screen Saver”. Moreover, it allows you to check the “App Version”. The main interface of the “Settings” page is shown in the following diagram.

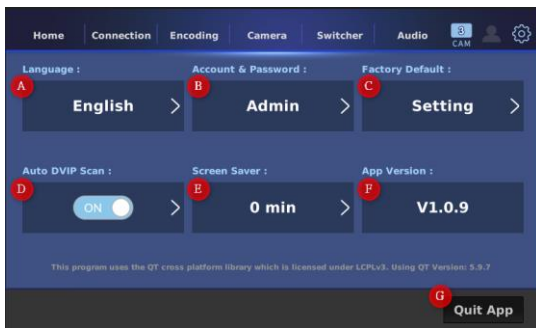

A: Language: Please press this button to select your desired language from English, Traditional Chinese or Simplified Chinese. After that, please press the “Apply” button. **Please note that the “Traditional Chinese” and “Simplified Chinese” interfaces are currently unavailable.**



B: Account & Password: Please press this button to change the administration password, to add a new user, to reset the user password and to delete the unwanted users. The main interface of the “Account & Password” is shown in the following diagram.

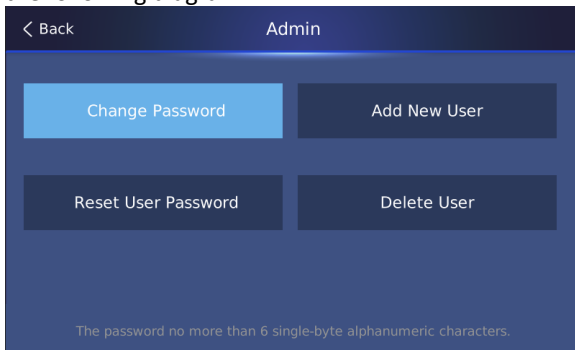

- Change Password: Please press this button to enter the new administration password by the keypad.
- Add New User: Please press “Add New User → User Name” to enter the user name of a new user account. Please press “Add New User → Setting” to enter the password for a new user account. After the new user name and password are entered, please press the “OK” button and then press the “Apply” button.
- Reset User Password: This button allows you to reset the user password. Please press this button. Please press the account name which the password should be changed and then press the “Apply” button. After that, you can see a reminder, please press “Reset”. And then please enter your new password and press the “OK” button.
- Delete User: This button allows you to delete a current user. Please press

this button and then press the user name which should be deleted. After that, please press the “Apply” button. You will see a reminder, please press the “Delete” button to delete the selected user.

C: Factory Default: This button allows you to reset the app to its factory default value. Please press this button and then you can see a reminder. After that, please press the “Yes” button to reset it.

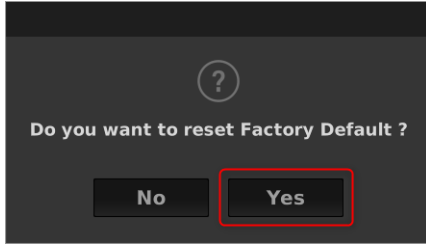

D: Auto DVIP Scan: Please press this button to turn on or turn off the Auto DVIP Scan function.

E: Screen Saver: This button allows you to set the wait time for activating the screen saver. Please press this button to adjust the wait time for activating the screen saver by a slider. The adjusting range is 0-100 min. After the adjustment is done, please press the “Apply” button to apply it.

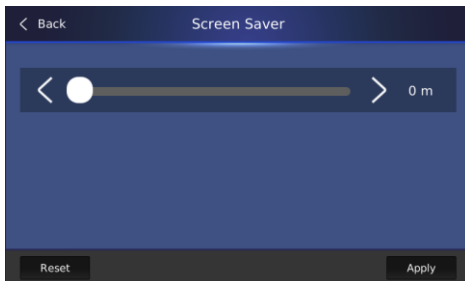

F: App Version: This option allows you to see the current ZR-1 app version.

G: Quit App: Please press this button to quit the ZR-1 app.

14. AI Auto-Tracking On/Off buttons for CAM A/CAM B/CAM C/CAM D: Those

four buttons  are used to turn on or turn off the AI Auto-

Tracking function when Datavideo AI Auto Tracking cameras are connected to the iCAST 10 NDI. You can connect up to 4 Datavideo AI Auto Tracking cameras to the HDMI input interfaces on the rear panel of the iCAST 10 NDI. Once the ZR-1 app detects that the connected cameras are not AI-enabled, those four buttons will be shown in white. If the ZR-1 app detects that the connected cameras are AI-enabled cameras, those four buttons will be shown in blue. At this time, you can press the CAM A, CAM B, CAM C or CAM D button to turn on the AI Auto-Tracking function. Once the AI Auto-Tracking function is turned on, those four buttons will be shown in red.

13.2.2 2 cams Interface-Home



1. Teacher Full: Press the “Teacher Full” button to show the half-body image of the teacher which is shot by the camera connected to the HDMI input 1 of the iCAST 10 NDI to the PGM external monitor.

2. Teacher + Wide Angle: Press the “Teacher + Wide Angle” button to show the full-body image of the teacher and the panoramic view of the classroom which is shot by the camera connected to the HDMI input 2 of the iCAST 10 NDI to the PGM external monitor.

3. PPT: The PPT button of the “2 cams” mode is the same as the PPT button in “3 cams” mode. Please refer to “4. PPT” in [13.2.1 3 cams Interface-Home](#) for details.

4. Document Camera: The Document Camera button of the “2 cams” mode is the same as the Document Camera button in “3 cams” mode. Please refer to

“5. Document Camera” in [13.2.1 3 cams Interface-Home](#) for details.

5. PIP A: The PIP A button of the “2 cams” mode is the same as the PIP A button in “3 cams” mode. Please refer to “6. PIP A” in [13.2.1 3 cams Interface-Home](#) for details.

6. PIP B: The PIP B button of the “2 cams” mode is the same as the PIP B button in “3 cams” mode. Please refer to “7. PIP B” in [13.2.1 3 cams Interface-Home](#).

7. Stream: The Stream button of the “2 cams” mode is the same as the Stream button in “3 cams” mode. Please refer to “8. Stream” in [13.2.1 3 cams Interface-Home](#) for details.

8. Record: The Record button of the “2 cams” mode is the same as the Record button in “3 cams” mode. Please refer to “9. Record” in [13.2.1 3 cams Interface-Home](#) for details.

9. Volume control slider: The Volume control slider of the “2 cams” mode is the same as the volume control slider in “3 cams” mode. Please refer to “10. Volume control slider” in [13.2.1 3 cams Interface-Home](#) for details.

10. 2 cams & 3 cams modes switch buttons: The 2 cams & 3 cams modes switch buttons of the “2 cams” mode are the same as the 2 cams & 3 cams modes switch buttons in “3 cams” mode. Please refer to “11. 2 cams & 3 cams modes switch buttons” in [13.2.1 3 cams Interface-Home](#) for details.

11. Account & Password login button: The Account & Password login button of the “2 cams” mode is the same as the Account & Password login button in “3 cams” mode. Please refer to “12. Account & Password login button” in [13.2.1 3 cams Interface-Home](#) for details.

12. Gear icon: The Gear icon of the “2 cams” mode is the same as the Gear icon in “3 cams” mode. Please refer to “13. Gear icon” in [13.2.1 3 cams Interface-Home](#) for details.

13. AI Auto-Tracking On/Off buttons for CAM A/CAM B/CAM C/CAM D : The

Auto-Tracking On/Off buttons of the “2 cams” mode are the same as the Auto-Tracking On/Off buttons of the “3 cams” mode Please refer to “14. AI Auto-Tracking On/Off buttons for CAM A/CAM B/CAM C/CAM D” in [13.2.1.3 cams Interface-Home](#) for details.

13.2.3 Connection-for 3 cams & 2 cams Interfaces

The “Connection” interface allows you to see up to 6 connected devices including the iCAST 10 NDI. Moreover, the “Connection” interface also allows you to set the networking related settings, to save the current status of the connected devices and to load the previous saved connected devices. The “Connection” interface is shown in the following diagram.



1. Connect: This option allows you to see the current connected status of your devices. If this icon is shown in green, it means that the device is connected successfully.

2. Model Name: This option will show the model name of the connected devices.

3. Name: This option will show the name of the connected devices. You can tap the selected device “Name” button to modify the device name for a specific device.



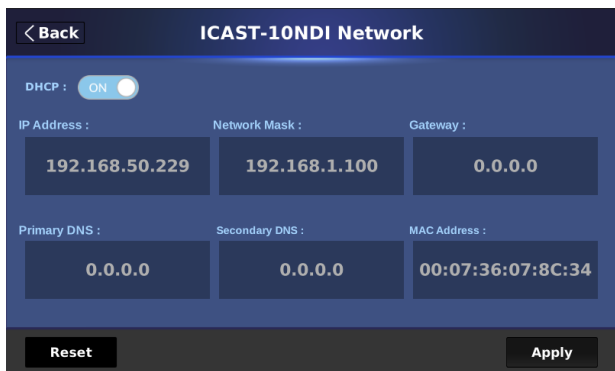

4. Network: This option allows you to see the IP address of the connected devices. You can also press the “Network” button of each connected device to modify the network settings.



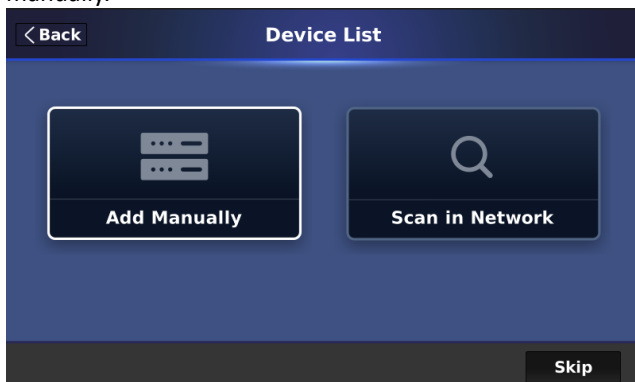

5. Add Device: If the connected devices can not be found by the automatic scanning, please press “Add Device→Scan in Network” to add your device automatically or press “Add Device→ Add Manually” to add your device manually.



6. Delete: This button allows you to delete the current connected device list which is shown on the screen. Please press “Delete  →Delete ” to delete the unwanted device.

7. Load: This button  allows you to load the pre-saved device list. When the device list is saved in advance, you can press this button to load it.

8. Save: This button  allows you to save a device list for further use. When all devices are connected and shown successfully, press this button to save the device list.

9. The left and right arrow buttons: These two buttons  allow you to switch between the first and the second pages of the device list.

13.2.4 Encoding-for 3 cams & 2 cams Interfaces

The “Encoding” interface provides three options including “Encoder”, “Record” and “Stream” for you to set encoding, recording and streaming related settings. The main interface of the “Encoding” is shown in the following diagram. Please press the “Encoder” button to enter the “Encoder” interface.

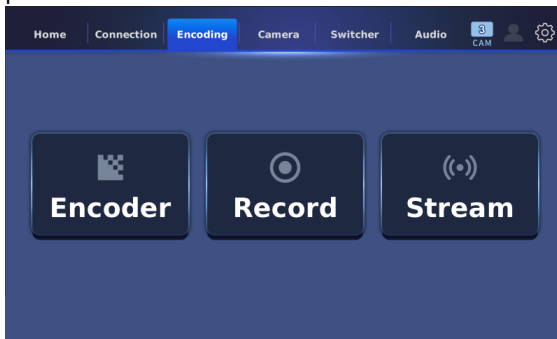

The main interface for the “Main” and “Sub” Encoders for the CH1, CH2, CH3, CH4, CH5 and PGM are the same. We will take the main encoder’s CH1 as an example.

Encoder

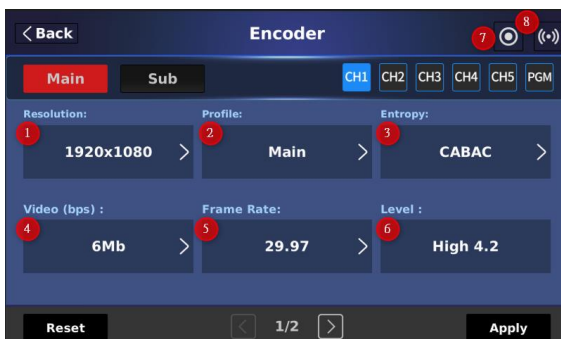

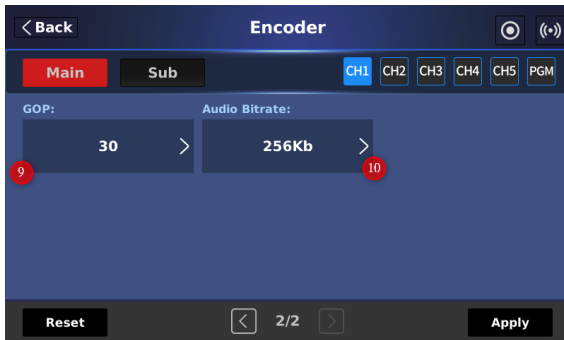

You can tap each option including “Resolution”, “Profile”, “Entropy”, “Video(bps)”, “Frame Rate” and Level to set your desired value. After that, please press the “Save” button in each page. After all of the parameters are set, please press the “Apply” button. Press the “Reset” button to reset it to factory default value.

1. Resolution: This option allows you to set your desired resolution for the main encoder or sub encoder.



2. Profile: This option allows you to set your desired “Profile” including “Baseline”, “High” and “Main” profiles.

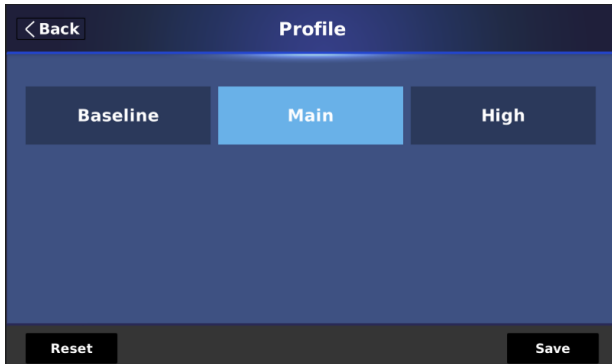

3. Entropy: You can select “CAVLC” or “CABAC” from the “Entropy” page which is shown in the following diagram.

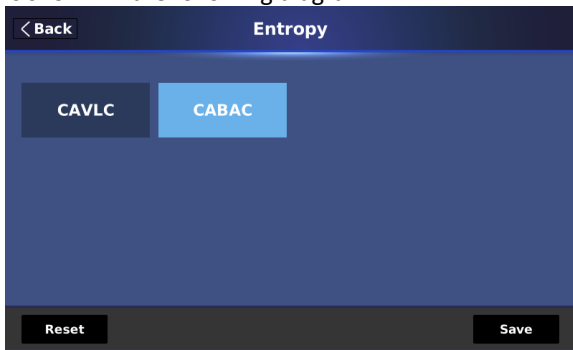

4. Video (bps): This option allows you to select your desired video Bitrate.

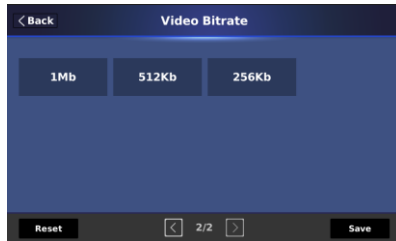

5. Frame Rate: This option allows you to select your desired frame rate for the main or sub encoder.

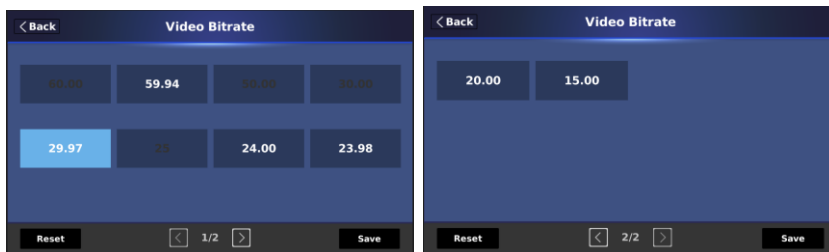

6. Level: The “Level” option is fixed at “High 4.2” and can not be adjusted by users.

7. “Record” icon: You can press this icon  to switch to the “Recorder” page of the “Encoding” option.

8. “Stream” icon: You can press this icon  to switch to the “Stream” page of the “Encoding” option.

9. GOP: This option allows you to select your desired “GOP” value.

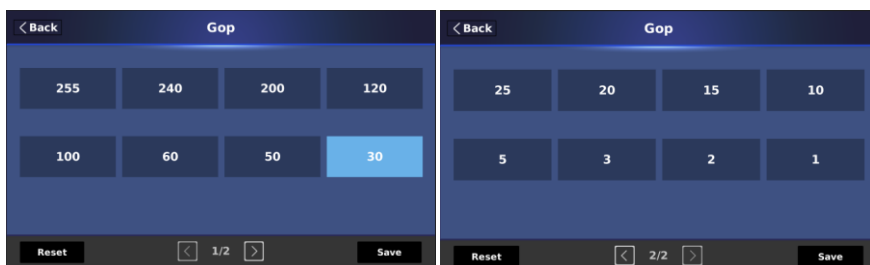

10. Audio Bitrate: This option allows you to set your desired audio bitrate.

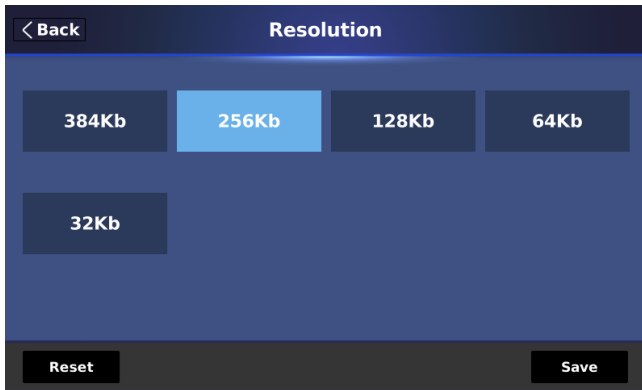

Record



1. Encoder Source: This option allows you to select “Main Encoder” or “Sub Encoder” as the encoder source. Moreover, this option can be disabled.

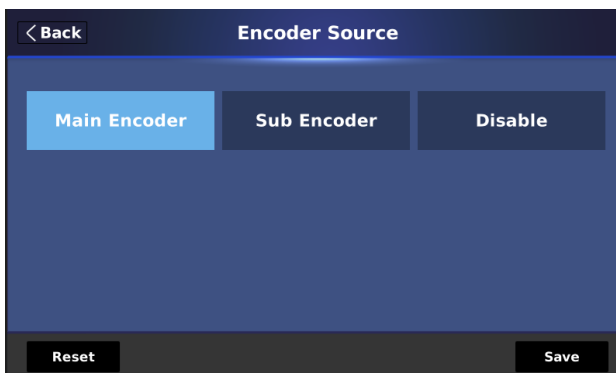

2. File Name: This option allows you to set the file name of the recorded file. Please enter your desired file name and then press the “OK” button.

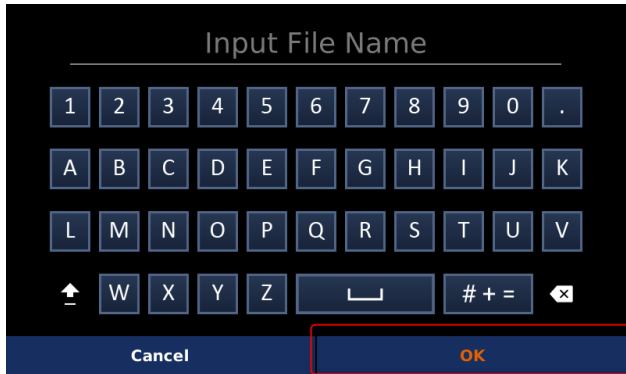

3. Type: This option allows you to set the file type for the recorded file.

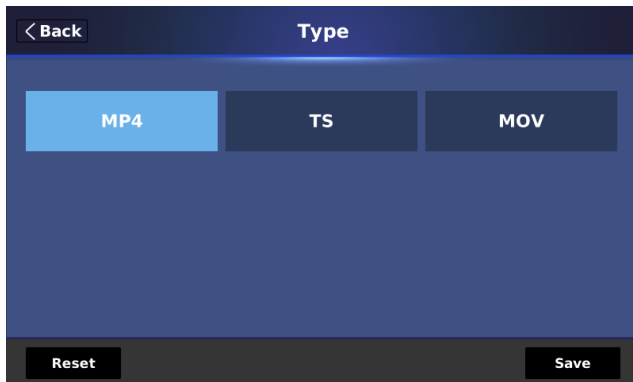

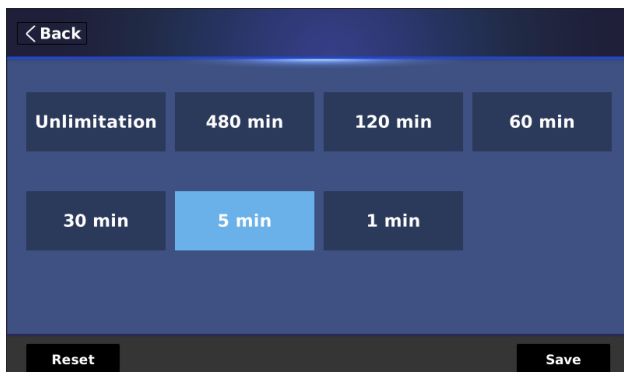

4. Recording Time: This option allows you to set the recording time for the recorded file.

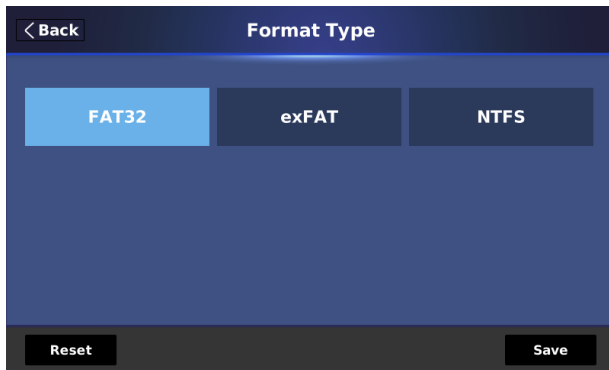
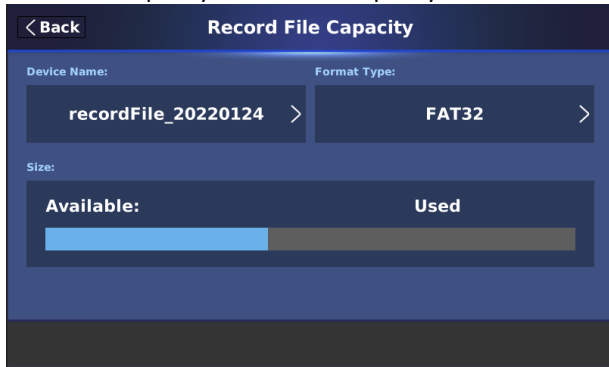

5. Storage Capacity: This option allows you to set the “Format Type” of the storage media. Moreover, this option allows you to see the “Device Name”, “Available Capacity” and “Used Capacity”.



6. “Encoder” icon & “Stream” icon: You can press the “Encoder” icon  to switch to the “Encoder” page. You can press the “Stream” icon  to switch to the “Stream” page.

Stream

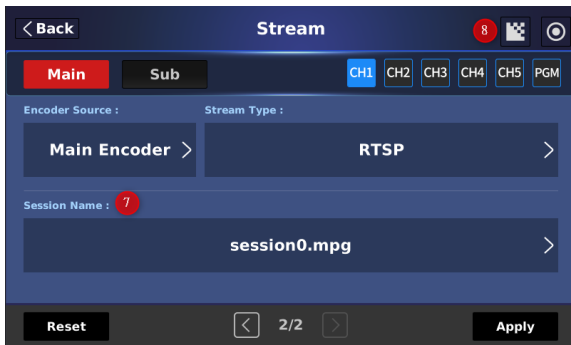
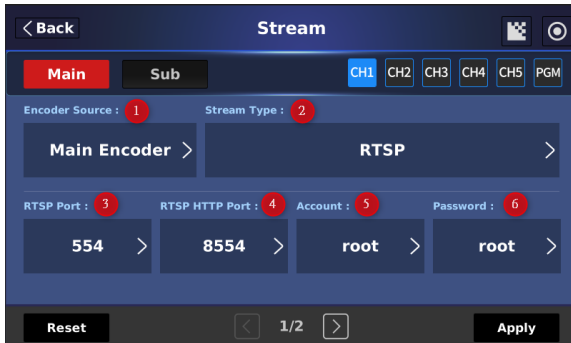

1. Encoder Source: This option allows you to set the encoder source for streaming.

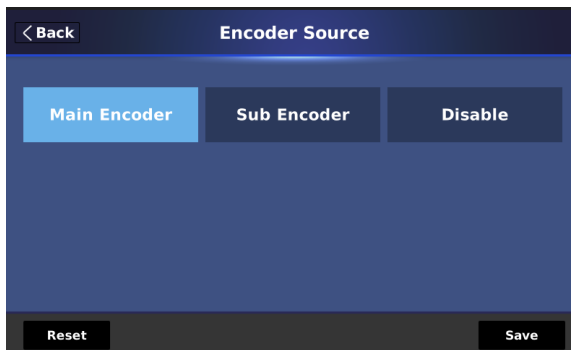

2. Stream Type: This option provides you many stream types including RTSP, RTMP, TS, HLS, NDI and SRT for you to select.

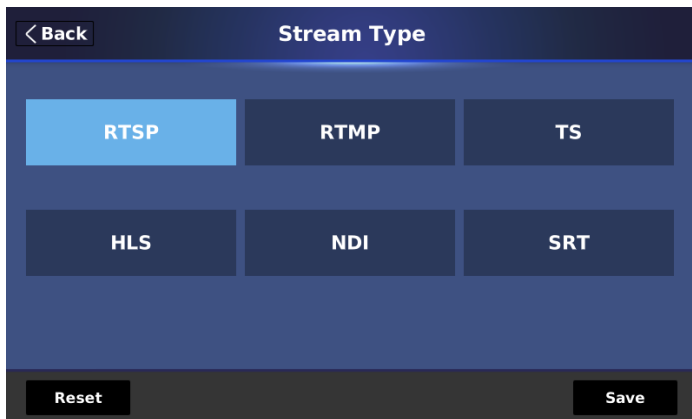

3. RTSP Port: The default port number is 554 or you can tap this option to modify the port number.

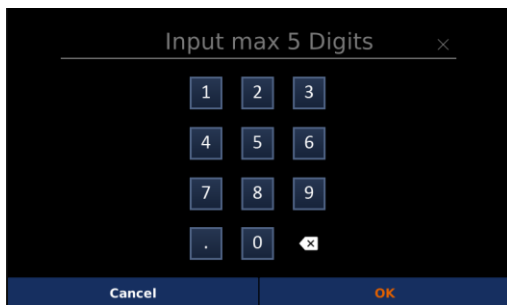

4. RTSP HTTP Port: The default port number is 8554 or you can tap this option to modify the port number.

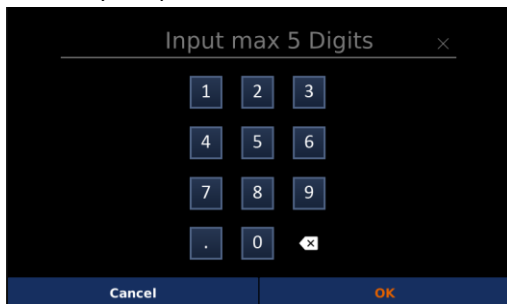

5. Account: This option provides you the “Account” of the streaming, the default value is “root” or you can tap this option to modify the password. .

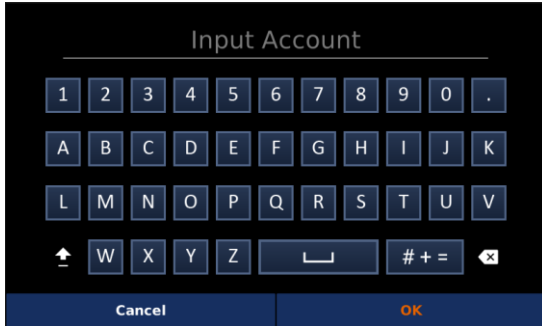



6. Password: This option provides you the “Password” of the streaming, the default value is “root” or you can tap this option to modify the password.



7. Session Name: Please press this option to enter the session name.



8. “Encoder” icon & “Record” icon: You can press the “Encoder” icon  to switch to the “Encoder” page. You can press the “Record” icon  to switch to the “Record” page.

13.2.5 Camera-for 3 cams & 2 cams Interfaces

The “Camera” option allows you to set the camera related parameters including “White Balance”, “FOCUS”, “IRIS”, “ZOOM IN” and “ZOOM OUT”. Moreover, you can also store up to 4 preset positions for each connected camera. The camera interface is shown in the following diagram.



1. White Balance: This section allows you to adjust the “White Balance” related settings.

- AUTO: Press this button to apply the Auto White Balance.
- ONE PUSH: Press this button to apply the One-Push White Balance.
- MANUAL: Press this button and then the “R/B GAIN” button will be lit for you to adjust the R Gain or B Gain manually. You can press the slider or the “+ & -” buttons for adjusting. Press the “Back” button to go back to previous page.



2. FOCUS: This section allows you to apply the Auto FOCUS setting or to adjust the FOCUS manually.

- AUTO: Press this button to apply the Auto FOCUS.
- MANUAL: Once the “MANUAL” button is pressed, you can adjust the “FOCUS” manually by pressing the “+ & -” buttons.

3. IRIS: This section allows you to apply the Auto IRIS setting or to adjust the IRIS manually.

- AUTO: Press this button to apply the Auto IRIS.
- MANUAL: Once the “MANUAL” button is pressed, you can adjust the “IRIS” manually by pressing the “+ & -” buttons.

4. CAMERA CONTROL: The “ZOOM IN” and “Zoom OUT” buttons allow you to control the “Zoom In” and “Zoom OUT” function. The slider allows you to control the zoom in, zoom out, panning and tilting speeds. Press the “UNLOCK” button to lock or unlock the “CAMERA CONTROL” section. If this section is locked, the joystick and the slider can not be used. If the “UNLOCK” button is unlocked, you can control this section.

5. CAMERA: This section allows you to select “CAM A”, “CAM B”, “CAM C” or “CAM D”.

6. POSITION: The 1 to 4 and the “STORE” buttons allow you to set up to 4 preset positions for each camera.

How to Store a Preset Position

1. At first, please make sure that the desired parameters and angle of the camera are set in advance for CAM A, CAM B, CAM C or CAM D
2. Please press the “CAM A”, “CAM B”, “CAM C” or “CAM D” button that you want to store the preset position.
3. Please press the “STORE” button and the position button “1”, “2”, “3” or “4”.



How to Recall a Preset Position

After the preset position is presaved, please press the “CAM A”, “CAM B”, “CAM C” or “CAM D” button in the “CAMERA” section. After that, please press the 1, 2, 3 or 4 button from the “POSITION” section to recall your preset position.

13.2.6 Switcher-for 3 cams & 2 cams Interfaces

The “Switcher” tab allows you to set a lot of PGM modes including “Quad View 1”, “Quad View 2”, “Full Screen”, “POP”, “Side By Side”, “PIP 1”, “PIP 2”, “PIP 3”, “PIP 4” and “PIP 5”. Moreover, the “Switcher” tab provides a PIP 5 Window Editor for you to edit detailed parameters for the PIP 5. The main interface for the “Switcher” tab is shown in the following diagram.



1. Quad View 1: Once this button is pressed, the Quad view screen for iCAST 10 NDI’s HDMI input 1, HDMI input 2, HDMI input 3 and HDMI input 4 will be shown on the external connected PGM screen.

2. Quad View 2: Once this button is pressed, the Quad view screen for iCAST 10 NDI’s HDMI input 1, HDMI input 2, HDMI input 3 and HDMI input 5 will be shown on the external connected PGM screen.

3. Full Screen: Once this button is pressed, you can press one button from button 1 to button 5 on the right side of the “PGM SOURCE” section to be shown on the external connected PGM screen.



4. POP: Once the “POP” button is pressed, you can select you desired input sources from the input 1 to input 5 to combine with your POP PGM screen by pressing buttons on the “PGM SOURCE” section.

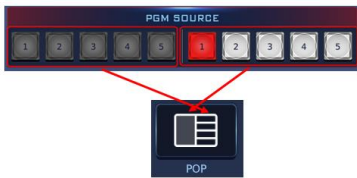

5. Side By Side: Once this button is pressed, the selected two input sources from the “PGM SOURCE” section will be shown on the external PGM screen by the “Side By Side” layout.



6. PIP 1: Once the “PIP 1” button is pressed, you can select one input from the button 1 to button 5 on the right side of the “PGM SOURCE” section to be the main PGM screen and then you can also select another input from the button 1 to button 5 on the left side of the “PGM SOURCE” section as the sub window for the PIP which will be shown on the top-left side of the PGM screen.





7. PIP 2: Once the “PIP 2” button is pressed, you can select one input from the button 1 to button 5 on the right side of the “PGM SOURCE” section to be the main PGM screen and then you can also select another input from the button 1 to button 5 on the left side of the “PGM SOURCE” section as the sub window for the PIP which will be shown on the top-right side of the PGM screen.



8. PIP 3: Once the “PIP 3” button is pressed, you can select one input from the button 1 to button 5 on the right side of the “PGM SOURCE” section to be the main PGM screen and then you can also select another input from the button 1 to button 5 on the left side of the “PGM SOURCE” section as the sub window for the PIP which will be shown on the bottom-left side of the PGM screen.



9. PIP 4: Once the “PIP 4” button is pressed, you can select one input from the button 1 to button 5 on the right side of the “PGM SOURCE” section to be the main PGM screen and then you can also select another input from the button 1 to button 5 on the left side of the “PGM SOURCE” section as the sub window for the PIP which will be shown on the bottom-right side of the PGM screen.



10. PIP 5: Once the “PIP 5” button is pressed, you can select one input from the button 1 to button 5 on the right side of the “PGM SOURCE” section to be the main PGM screen and then you can also select another input from the button 1 to button 5 on the left side of the “PGM SOURCE” section as the sub window for the PIP. The “Scale”, “Position X”, “Position Y”, “Width” and

“Height” of the “PIP 5 Window” can be adjusted by the “PIP 5 Window Editor”.



11. PIP 5 Window Editor: Please press the “Edit” button below the PIP5 to enter the PIP 5 Window Editor. The main interface of the PIP 5 Window Editor is shown in the following diagram.

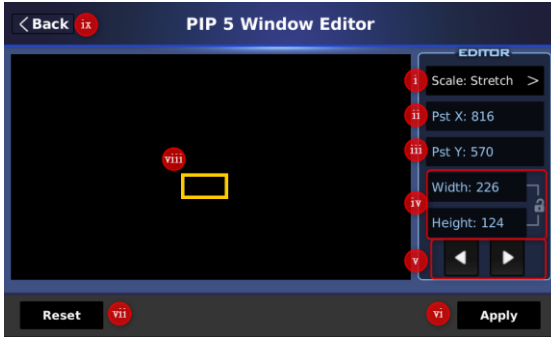

i. Scale: Please press this button to enter the “Scale” interface which is shown in the following diagram to determine the image scale in the PIP 5 window.



A: Scale buttons: You can determine the scale of the image in the PIP 5 window by pressing the “Stretch”, “Full” and “Fit” buttons.

B: Apply: After the desired scale is selected, please press this “Apply” button to apply the selected scale.

C: Reset: Please press this button to resume back to the previously selected “Scale” type.

D: Back: Press this button to go back to the previous page.

ii & iii: Pst X & Pst Y: These “Pst X” and “Pst Y” buttons allow you to determine the X & Y coordinates of the PIP 5 window within the whole screen. Please press the “Pst X” and “Pst Y” buttons to enter your desired coordinates by the keypad which is shown in the following diagram and then press the “OK” button. If you press the “Cancel” button, you can also adjust those coordinates by the left and right arrows  to decrease or increase the number.

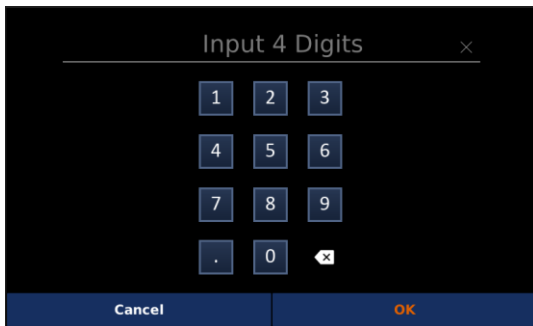

iv. Width & Height: The “Width” and “Height” button allow you to determine the width and height of the PIP 5 Window. You can press the “Width” and “Height” buttons to enter your desired numbers. The way for adjusting the width and height is the same as the previous-mentioned “Pst X & Pst Y” section.

v. Left & Right Arrow buttons: For “Pst X”, “Pst Y”, “Width” and “Height” options, if you press the “Cancel” button rather than enter the number by the keypad, you can decrease or increase the number directly by using the left and right arrow buttons.

vi. Apply: After all of the parameters are set, please press this “Apply” button to apply those settings for the PIP 5 window.

vii. Reset: Once the position of the PIP 5 window is set and applied by pressing the “Apply” button. When the PIP 5 window moves to any point on the whole screen, you can press the “Reset” button to resume the PIP 5 window back to its previously-saved position.

viii. PIP 5 Window Frame: This window frame presents the position which the PIP 5 window will appear on the external screen (the black section) and you can touch any point of the black section by your finger to change the position of the PIP 5 window frame directly.

ix. Back: Please press this button to go back to the previous page.

12. PGM Source buttons-left side: Those five buttons allow you to select the PGM image source for the PIP sub window.

13. PGM Source buttons-right side: Those five buttons allow you to select the PGM image source for the PIP main screen.

14. LOWER THIRD: This button allows you to loop the presaved “News” and “Graphic” on the external monitor. When the .txt file is uploaded and updated by the iCAST 10 NDI web UI and the “LOWER THIRD” button is pressed, the uploaded graphic will be shown and the content of the .txt file will be looped. If you press the “STOP” button on the “CG” page of the iCAST 10 NDI web UI, you can type the news string directly and click it directly to show it on the external monitor.

15. News: If the .txt file is selected and uploaded in the iCAST 10 NDI web UI in advance, you can press the News button to loop the News on the external PGM screen.

16. Graphic: If a .jpg or .png file is selected and uploaded in the iCAST 10 NDI web UI and all related parameters are set in advance, you can press the “Graphic” button to show the uploaded image on the external PGM screen.

17: LOGO: If a .jpg, jpeg, bmp, png or gif file is selected and uploaded in the iCAST 10 NDI web UI and all related parameters are set in advance, you can press the “LOGO” button to show the uploaded image on the external PGM screen.

18. ANIMAT: If a .jpg, jpeg, bmp, png or gif file is selected and uploaded in the iCAST 10 NDI web UI and all related parameters are set in advance, you can press the “ANIMAT” button to show the uploaded animation on the external

PGM screen.

13.2.7 Audio-for 3 cams & 2 cams Interfaces

The “Audio” tab allows you to adjust the volume and delay for all audio channels. There are two pages for the “Audio” tab. The main interface for the “Audio” tab is shown in the following diagram.



The above-mentioned interface allows you to adjust the audio volume and delay for all audio channels by using sliders. Moreover, you can tap the speaker icon  to turn on or to mute a specific audio channel. For XLR and Line In external audio sources, you can tap the “Audio Standard” button to select your desired audio standard. Please select the audio standard and then press the “Apply” button to apply it.

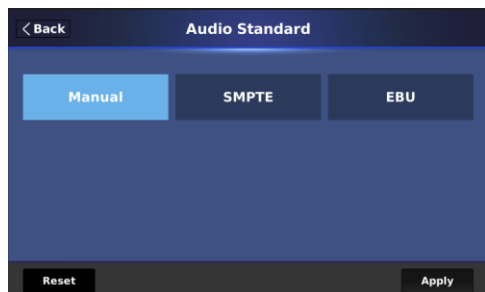

For AUX 1 and AUX 2, you can select different audio sources from “IP Stream/NDI 1”, “IP Stream NDI 2”, “IP Stream NDI 3”, “Web RTC” or “Audio Over IP”. Please press the “Source Select” button to enter the “Source Select” page. Please select your desired source and then press the “Apply” button.

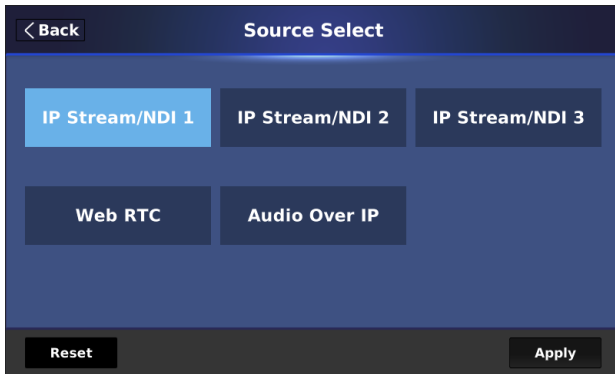

Chapter 14 Interface Introduction of the TPC-700/TPC-700P Built-in TVS-2000A App

Please pay attention that you need to finish the setup between the TVS-2000A main unit & TPC-700/TPC-700P. Moreover, you need to set the TVS-2000A PC version shortcut keys in advance. After that, you can use the TPC-700/TPC-700P built-in TVS-2000A app to control your TVS-2000A PC version. For the setup of the TPC-700/TPC-700P & TVS-2000A and the way to set the TVS-2000A PC version shortcut keys, please refer to “**Downloads**→**Others**” from Datavideo official website’s(www.datavideo.com) TPC-700/TPC-700P product pages. After the setup is finished, please press the icon of the TVS-2000A app and then you can see the main interface of the TVS-2000A app which is shown in the following diagram. For the introduction of the TVS-2000A app interface, please refer to the following section.

14.1 Home





1. **Button 1:** The Button 1  allows you to show the far view of the front camera angle to the PGM screen of the TVS-2000A. The Button 1 is corresponding to the shortcut key “F1” in the TVS-2000A PC version software.

2. **Button 2:** The Button 2  allows you to show the near view of the front camera angle to the PGM screen of the TVS-2000A. The

Button 2 is corresponding to the shortcut key “F2” in the TVS-2000A PC version software.

3. **Button 3:** The Button 3  allows you to show the near view of the right side camera angle to the PGM screen of the TVS-2000A. The Button 3 is corresponding to the shortcut key “F3” in the TVS-2000A PC version software.

4. **Button 4:** The Button 4  allows you to show the near view of the left side camera angle to the PGM screen of the TVS-2000A. The Button 4 is corresponding to the shortcut key “F4” in the TVS-2000A PC version software.

5. **Button 5:** The Button 5  allows you to show the image source of the AUX input to the PGM screen of the TVS-2000A. The Button 5 is corresponding to the “AUX” button which is located on the PGM button row.

6. **Button 6:** The Button 6  allows you to show the DSK1 and DSK 2 to the PGM screen of the TVS-2000A. The Button 6 is corresponding to the shortcut key “F5” in the TVS-2000A PC version software.

7. **Button 7:** The Button 7  allows you to remove the DSK1 and DSK2 from the PGM screen of the TVS-2000A. The Button 7 is corresponding to the shortcut key “F6” in the TVS-2000A PC version software.

8. **The Gear (Setup) icon:** The Gear icon allows you to set “Language”, “Studio Image”, “Screen Saver” and to check the current software version. Press the gear icon  to enter the “Setup” page. The interface of the “Setup” page is shown in the following diagram

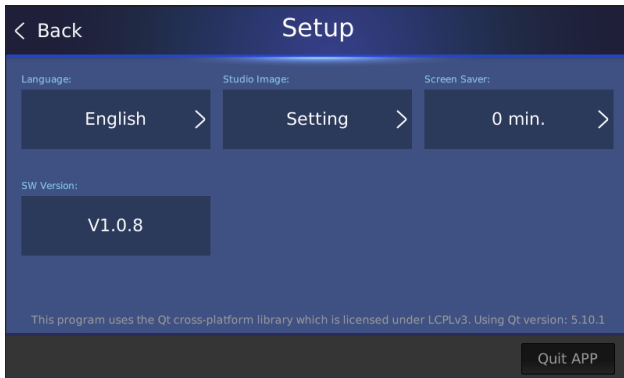

- **Language:** The “Language” button allows you to choose your desired language for displaying the user interface of the TVS-2000A app. Please press this button to choose your desired display language for the TVS-2000A app. The English user interface is ready now, however, the traditional Chinese and simplified Chinese user interfaces will be available in the near future.
- **Studio Image:** The “Studio Image” button allows you to change the thumbnail of the Studio A, B, C, or D for displaying in the “Studio” option.

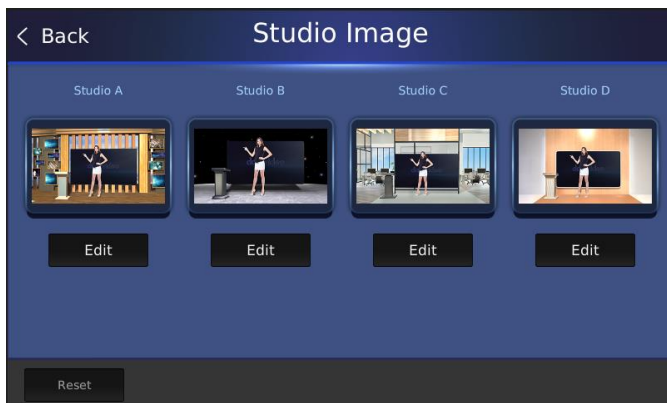

Please follow the following steps to replace the thumbnail for the Studio A, B, C or D.

1. At first, please make sure that the TVS-2000A and TPC-700 are connected successfully.
2. Please press the TVS-2000A app icon to open the TVS-2000A app.



3. After the TVS-2000A app is opened, please press the gear icon to enter the “Setup” interface.



4. After entering the “Setup” interface, please press the “Studio Image” button.

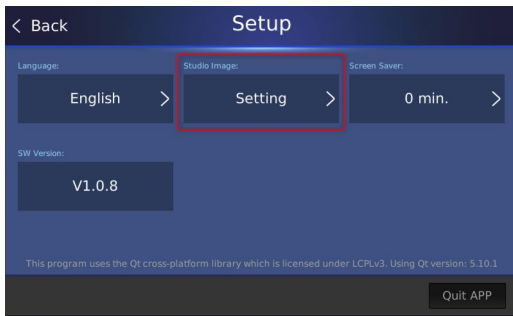

5. You can see the “Studio Image” interface. We will take Studio A as an example. Please press the “Edit” button.

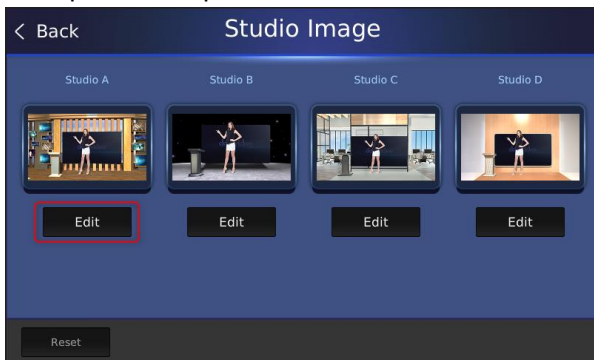

6. You can see the default Studio A thumbnail, which is the thumbnail 02.



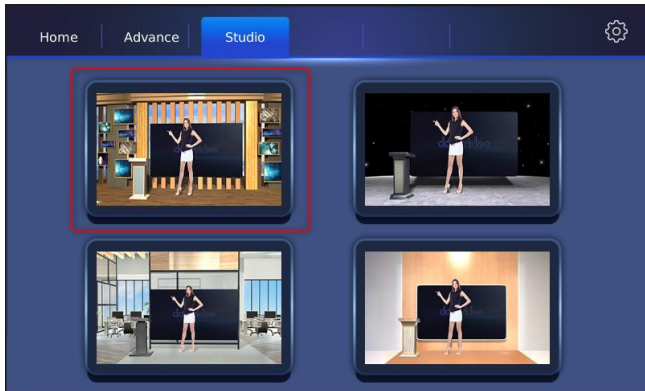

7. If you want to exchange the thumbnail between Studio A and Studio B, please enter the Setup page and then press “Studio Image→Studio A Edit to select the thumbnail 03. And then press the “Apply” button.

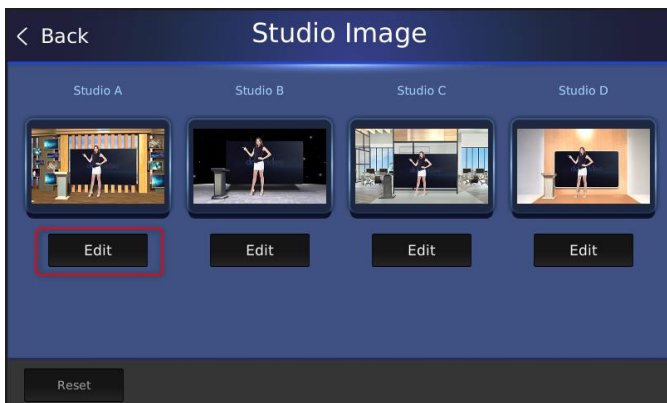
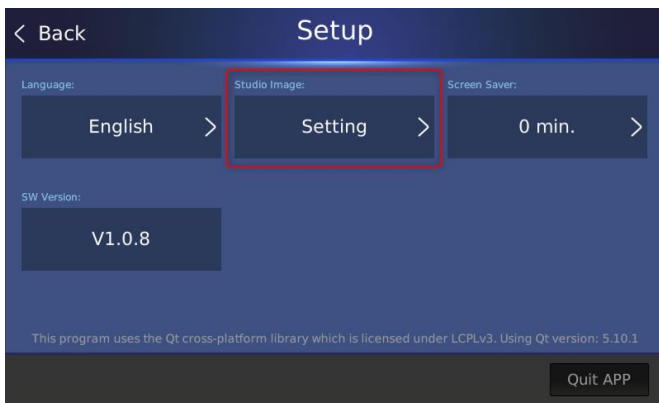

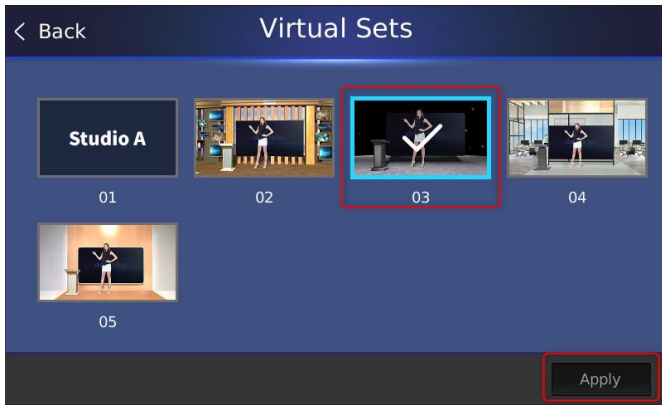

8. After that, please press “Studio Image→Studio B Edit” to select the thumbnail 02. And then press the “Apply” button.

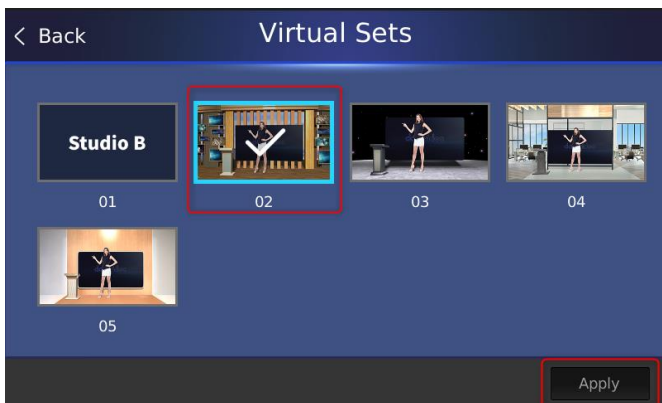
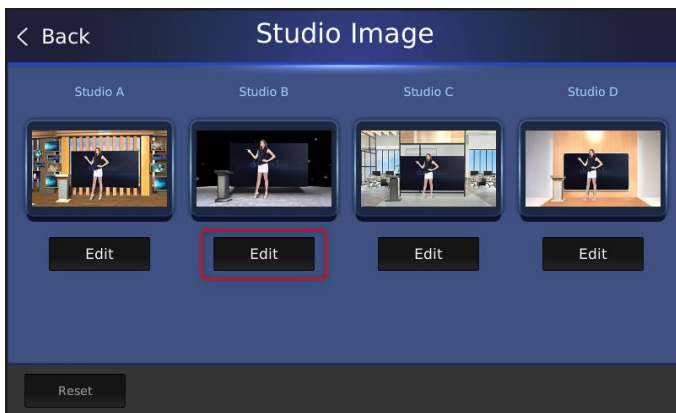

9. Finally, you can see that the thumbnails of the Studio A and Studio B are successfully exchanged.

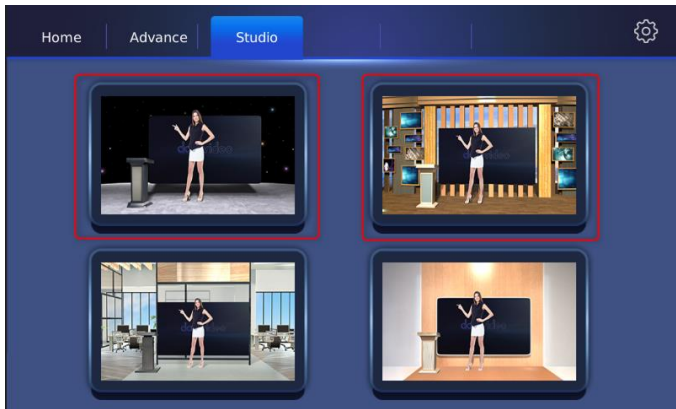

- **Screen Saver:** This Screen Saver option allows you to set the wait time for activating the screensaver. Please press the “Screen Saver” button and then you can adjust the wait time by the slider. After the wait time is set, please press the “Save” button to save the setting.

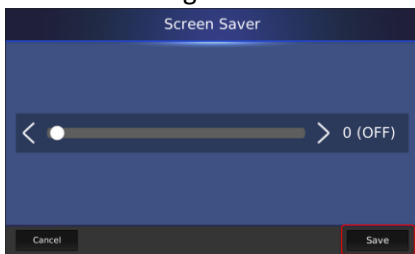

- **SW Version:** The SW Version column allows you to see the current software version of the TVS-2000A app. Moreover, please press the “Quit APP” button to quit the TVS-2000A app.

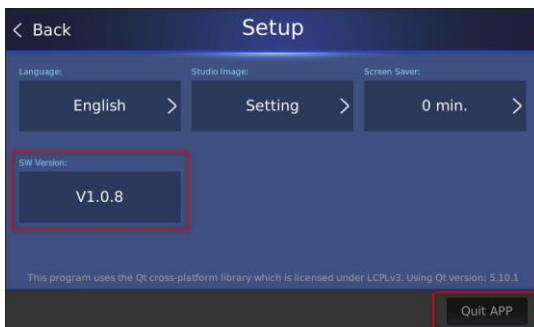

14.2 Advance



1. **Button 1:** The Button 1 for the “Advance” tab is the same as the Button 1 in the “Home” tab. Please refer to [14.1 Home](#)

2. **Button 2:** The Button 2 for the “Advance” tab is the same as the Button 2 in the “Home” tab. Please refer to [14.1 Home](#)

3. **Button 3:** The Button 3 for the “Advance” tab is the same as the Button 3 in the “Home” tab. Please refer to [14.1 Home](#)

4. **Button 4:** The Button 4 for the “Advance” tab is the same as the Button 4 in the “Home” tab. Please refer to [14.1 Home](#)

5. **Button 5:** The Button 5 for the “Advance” tab is the same as the Button 5 in the “Home” tab. Please refer to [14.1 Home](#)

6. **Button 6:** The Button 6 is corresponding to the “STILL/GRAB” button of the TVS-2000A PC version, it allows you to capture still images from TVS-2000A’s “Program” screen.

7. **Button 7:** The Button 7 is corresponding to the “CAPTURE” button  of the TVS-2000A PC version, it allows you to start and stop a video recording for the “Program” screen. When the Button 7 is shown in red, it means the video recording is in progress. If the

Button 7 is shown in white, it means that the video recording is not activated or is stopped.

Video Recording is in progress

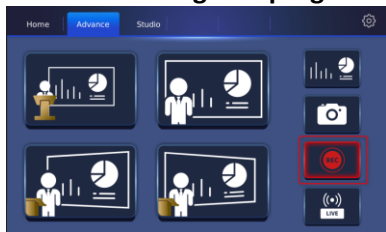

No Video Recording.

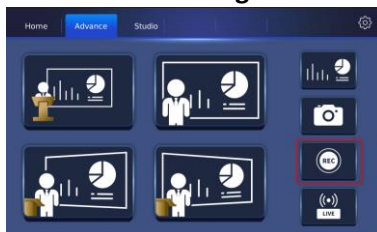

8. **Button 8:** The Button 8 is corresponding to the “STREAM” button  of the TVS-2000A PC version, it allows you to start and stop a video live streaming for the “Program” screen. When the Button 8 is shown in red, it means the video live streaming is in progress. If the Button 8 is shown in white, it means that the video live streaming is not activated or is stopped.

Live Streaming is in progress



No Live Streaming

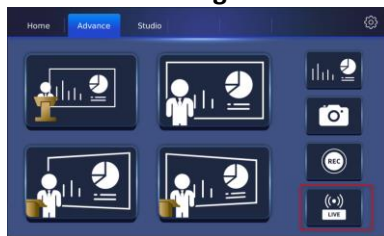

9. **Button 9 :** The Button 9 for the “Advance” tab is the same as the Button 8 in the “Home” tab. Please refer to [14.1 Home](#)

14.3 Studio

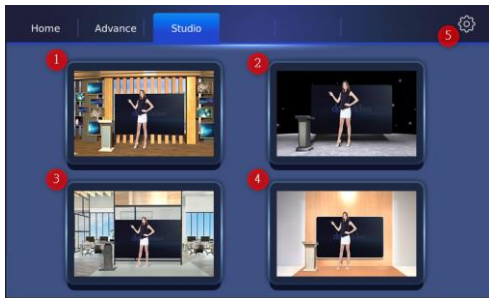

1. **Studio A:** The “Studio A” button allows you to recall the presaved Studio A virtualset in the TVS-2000A PC version by pressing the Studio A button only. The Studio A button corresponds to the **F7 shortcut key** in the TVS-2000A PC version. Once the F7 shortcut key is set in advance, you can recall the Studio A virtualset by pressing the **Studio A button**.

2. **Studio B:** The “Studio B” button allows you to recall the presaved Studio B virtualset in the TVS-2000A PC version by pressing the Studio B button only. The Studio B button corresponds to the **F8 shortcut key** in the TVS-2000A PC version. Once the F8 shortcut key is set in advance, you can recall the Studio B virtualset by pressing the **Studio B button**.

3. **Studio C:** The “Studio C” button allows you to recall the presaved Studio C virtualset in the TVS-2000A PC version by pressing the Studio C button only. The Studio C button corresponds to the **F9 shortcut key** in the TVS-2000A PC version. Once the F9 shortcut key is set in advance, you can recall the Studio C virtualset by pressing the **Studio C button**.

4. **Studio D:** The “Studio D” button allows you to recall the presaved Studio D virtualset in the TVS-2000A PC version by pressing the Studio D button only. The Studio D button corresponds to the **F10 shortcut key** in the TVS-2000A PC version. Once the F10 shortcut key is set in advance, you can recall the Studio D virtualset by pressing the **Studio D button**.

5. Gear Icon: Please press the gear icon to enter the “Setup” page. This option is the same as the gear icon in “Home” and “Advance” pages. Please refer to [14.1 Home](#) for details.

Chapter 15. Software Update (App Manage SW)

Please follow following steps for updating the software for the TPC-700/TPC-700P.

1. Please download the latest TPC-700/TPC-700P software from the Datavideo official website www.datavideo.com.
2. Please unzip the downloaded software “TPC700_product model name_v x.x.x” in your PC or laptop.
3. There is a folder with the latest software update files which the folder name is “datavideo” after the software is unzipped.
4. Please copy the whole “datavideo” folder to the root directory of your USB thumb drive.
5. Please insert your USB thumb drive with the latest TPC-700/TPC-700P software into the USB port which is located at the left side of the TPC-700/TPC-700P.
6. Please turn off and then turn on the power of the TPC-700/TPC-700P.
7. The screen of the TPC-700/TPC-700P will be shown in the following diagram and the software update procedure will be started automatically.



8. After the software update procedure is finished, the following screen will be shown, please tap the “OK” button and then all of the software update procedure is done.

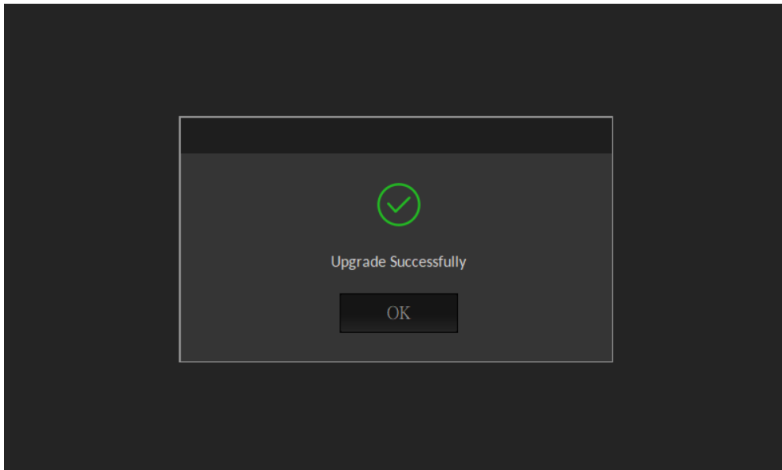

Note: After the software update is finished, there is a file which the file name is “done” will be generated automatically by the TPC-700/TPC-700P system and will be saved in your USB thumb drive. If users want to update the same version of the software for the next time, please remember to delete that “done” file in advance.

Chapter 16. Dimensions

Unit: mm

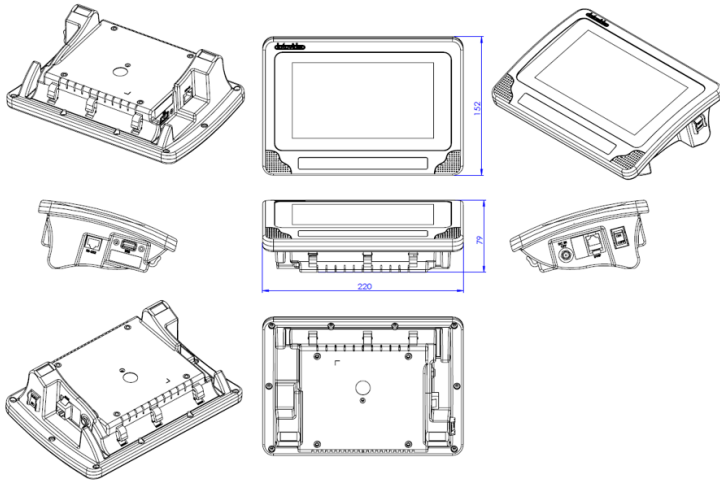

Chapter 17. Specifications

TPC-700/TPC-700P Specifications	
Touch Screen	7" capacitive touch screen
Touch Screen Resolution	800 x 480
Software Upgrade	via USB 2.0 interface
Control Protocol	via RS-232(RJ-45 interface)
Power	DC 12V
PoE	802.3af(For TPC-700P Only)
Power Consumption	10W
Dimension	220 x 152 x 79 (mm)
Weight	0.85Kg
Operating Temp.	0~40 °C

Appendix

Software Update Procedure for TPC-700 & TPC-700P

1. Introduction

Software update is performed by connecting a USB flash drive with the latest TPC-700/TPC-700P's "App manage " or "Apps for different product models" software files to the [USB] port which is located on the left side of the TPC-700 & TPC-700P.

This software update procedure applies to the following product.

Product Model	TPC-700/TPC-700P
Product Name	Touch Panel Controller/Touch Panel Controller with PoE

1. For the TPC-700/TPC-700P App Manage Software, there is one zip file with the file name: **tpc700_v2.0.15_20210714.zip**

2. For the TPC-700/TPC-700P App for each product model, there is one zip file with the file name (take SE-3200 as an example):
datavideo_se3200_v2.2.10.7zip

This document describes how to perform a software update on a Windows computer.

Screen images from the Windows 10 operating system are used in this document as an example. Images used in this document may differ from the actual screens.

For details on Windows and computer operations, please refer to the instruction manual of your computer.

2. Preparation

2.1 System Requirements

A computer that meets the following requirements is necessary to perform the Software update procedure.

Laptop	A normal laptop is needed.
USB Flash Drive	A USB 2.0 or USB 3.0 flash drive is needed.

Operation is not guaranteed on all computers that meet the above requirements

2.2 Software Update Preparation

The following items are required to perform this Software update. Please prepare these items in advance before performing the update.

TPC-700 or TPC-700Px 1	The TPC-700 or the TPC-700P is needed for updating the Software.
USB 2.0 or USB 3.0 USB Flash Drive x 1	The USB flash drive for saving the software files and for updating the software.
12V Power Adapter x 1	The 12V power adapter for the TPC-700/TPC-700P.
Laptop x 1	The laptop is used to download and save the software of the TPC-700/TPC-700P.
<p>Latest Software files</p> <p>The software for managing apps.</p> <ul style="list-style-type: none"> ● tpc700_v2.0.15_20210714.zip The app for different product models ● datavideo_se3200_v2.2.10.7z 	<p>The latest downloaded Software files.</p> <ul style="list-style-type: none"> ● [tpc700_v2.0.15_20210714.zip] is the software file for managing apps which are installed in the TPC-700/TPC-700P. ● [datavideo_se3200_v2.2.10.7z] is the app for different product models. (Take SE-3200 as an example).



2.3 System Connection Diagram

TPC-700



USB
Flash Drive



Power

TPC-700P



Note: Only the TPC-700P supports the “PoE” function. If the power is supplied by the Ethernet cable, please **DO NOT** use the DC IN power cable as the power source. If the power is supplied by the Ethernet cable, the power switch has no function at this time. If you want to reboot the TPC-700P, please remove and then plug in the Ethernet cable which is connected to the DVIP interface.

2.4 Checking the Software Version

- **The Software version for the “App Manage” software.**

2.4.1. Please connect a DC 12V power adapter.

Please connect a DC 12V power adapter to the TPC-700 or the TPC-700P.

2.4.2 Please turn on the power.

Please turn on the power of the TPC-700 or the TPC-700P.

2.4.3 You will see the initial screen.

You will see the initial screen. After that, please tap the “Settings” icon.

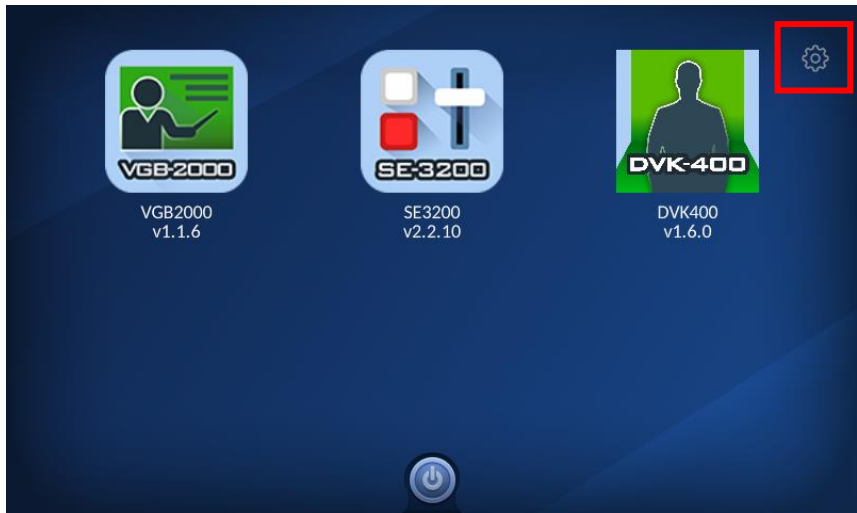

2.4.4. You will see the current “App Manage” software version.

The current version of the “App Manage” software will be shown as the following diagram.



- **The current version for the App for different product models.**

2.4.5. Please connect a DC 12V power adapter.

Please connect a DC 12V power adapter to the TPC-700 or the TPC-700P.

2.4.6 Please turn on the power.

Please turn on the power of the TPC-700 or the TPC-700P.

2.4.7 You will see the initial screen.

You will see the initial screen. After that, please click on the app icon of the product model for launching it. (Take SE-3200 App as an example).

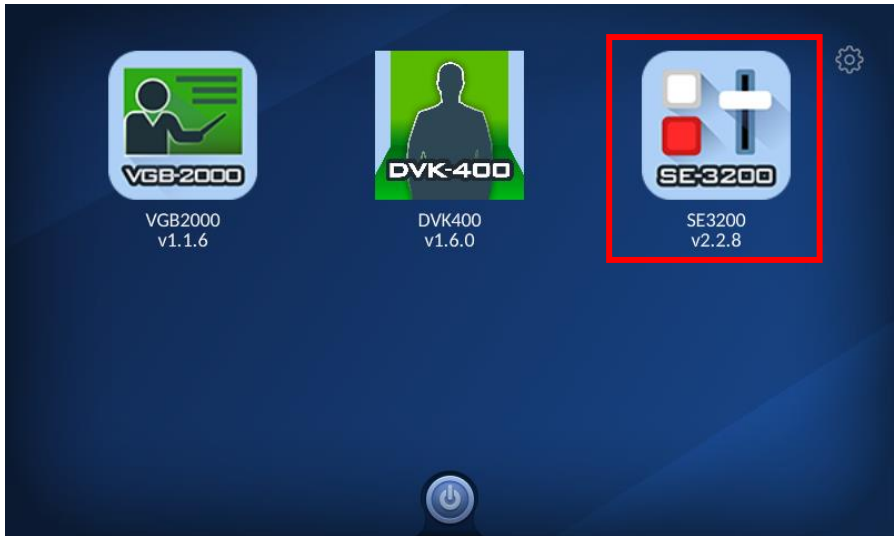

2.4.8 If the TPC-700 or the TPC-700P is not connected to the assigned product model, the following two dialogue boxes will be shown.

If the TPC-700 or the TPC-700P is not connected to the assigned product model, the following two dialogue boxes will be shown. Please tap the “Setup” button.

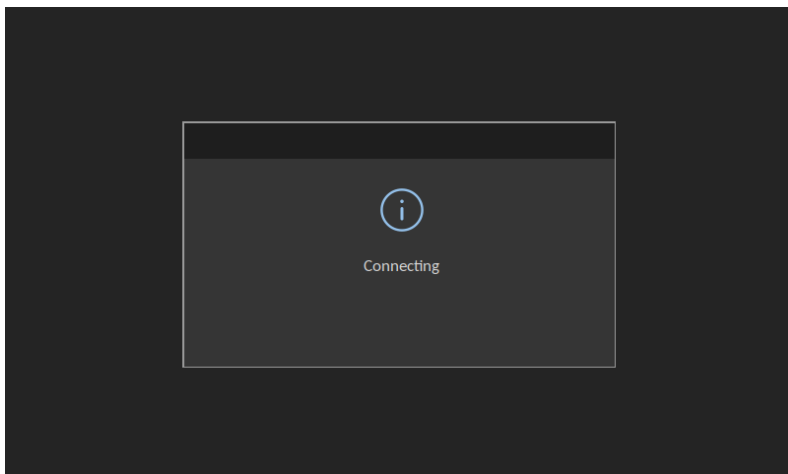

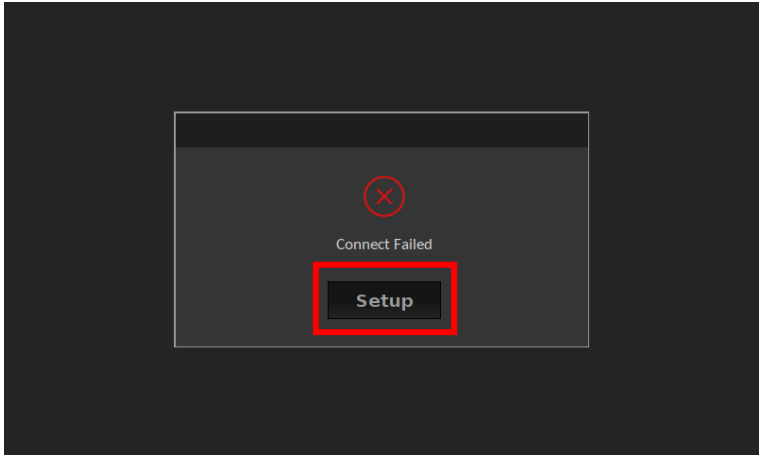

2.4.9 You can see the current app version of the selected model.

The current app version of the selected model will be shown in the following diagram.

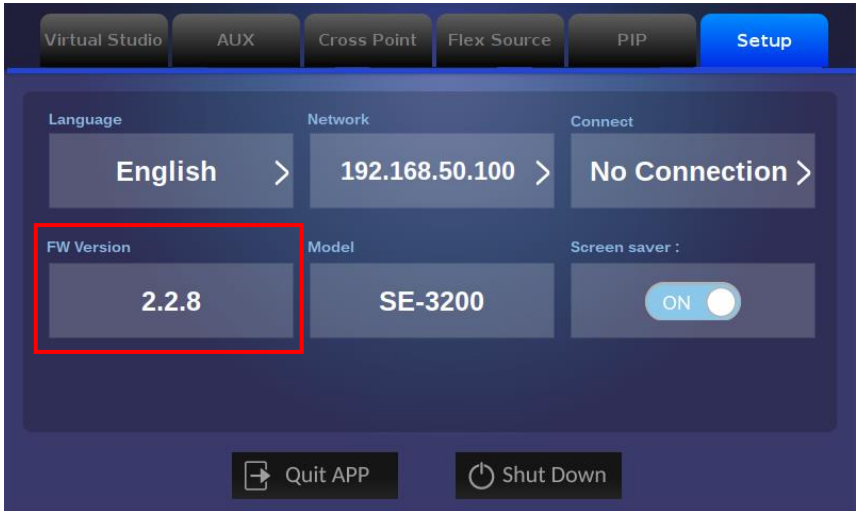

2.5 Preparing the Software

2.5.1. Download the Software

TPC-700 or the TPC-700P Product Page from the Datavideo website:

- TPC-700: <https://www.datavideo.com/product/TPC-700>
- TPC-700P: <https://datavideo.com/product/TPC-700P>

2.5.2. Unzip the Software

- The file name for the TPC-700/TPC-700P “App Manage” software is “**tpc700_v2.0.15_20210714**”.
- The file name for the TPC-700/TPC-700P App for the specific product model (take SE-3200 as an example) is “**datavideo_se3200_v2.2.10.zip**”

Please unzip the downloaded Software files into the hard disk of your laptop and then you can see the following file folders for the TPC-700 or the TPC-700P.

- **TPC-700/TPC-700P App Manage Software.**

 **datavideo**

- **App for the product model which is needed to be installed in the TPC-700/TPC-700P.**

 **datavideo**

3. Update

3.1 Updating the Software

- **TPC-700/TPC-700P App Manage Software**

3.1.1. Please save the unzipped “datavideo” file folder.

Please save the unzipped “datavideo” file folder into the root directory of your USB flash drive.

3.1.2. Please insert the USB flash drive to the USB interface.

Please insert the USB flash drive to the USB interface of the TPC-700/TPC-700P.

3.1.3. Please turn on the power of the TPC-700/TPC-700P.

Please turn on the power of the TPC-700/TPC-700P, the following screen will be shown and the software update procedure of the “App Manage” software will be started.

The image shows the 'datavideo' logo in white text on a dark blue background. The logo is centered and features a stylized font where the 'a' and 'i' are lowercase and the 'v' is lowercase, while 'd', 't', 'e', and 'o' are lowercase. The 'o' at the end is a circle with a dot inside, resembling a registered trademark symbol.

3.1.4. After the software update procedure is finished, the following screen will be shown.

After the software update procedure is finished, the following screen will be shown. Please tap the “Settings” icon to enter the “TPC-700 Setup” page.

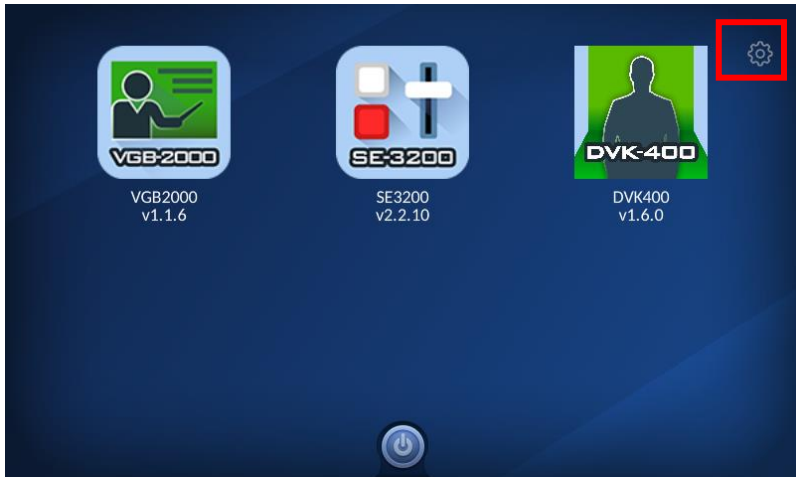

3.1.5. You can see the updated software version number.

You can see the updated software version number and the “App Manage” software for the TPC-700/TPC-700P is updated successfully.



- **App for Different Product Model**

3.1.6. Please save the “datavideo” file folder with the “tpc700.apkg” file.

Please save the “datavideo” file folder with the “tpc700.apkg” file into the root directory of your USB flash drive.

3.1.7. Please insert the USB flash drive to the USB interface.

Please insert the USB flash drive to the USB interface of the TPC-700/TPC-700P.

3.1.8. Please turn on the power of the TPC-700/TPC-700P.

Please turn on the power of the TPC-700/TPC-700P and then the following screen will be shown.





➤ Remove the old version App

3.1.9. Please tap the “Settings” icon.

Please tap the “Settings” icon from the initial screen.

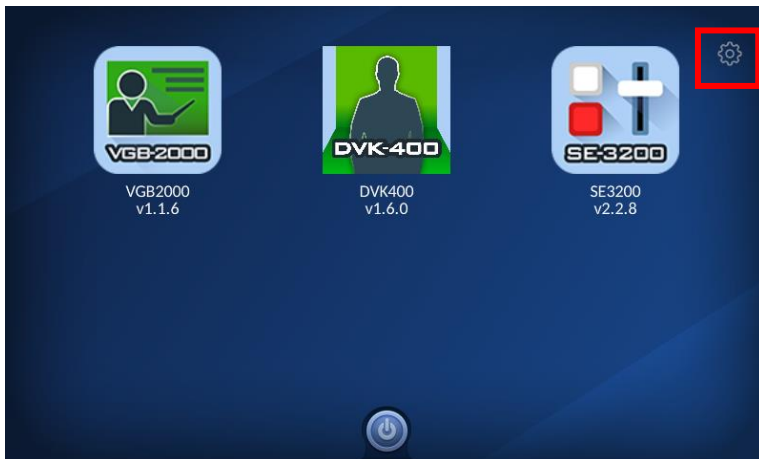

3.1.10. Please tap the “App Manage” option.

Please tap the “App Manage” option from the “TPC-700 Setup” page.



3.1.11. You can see all of the apps for different product models.

You can see all of the apps for different product models which are installed in the TPC-700/TPC-700P.

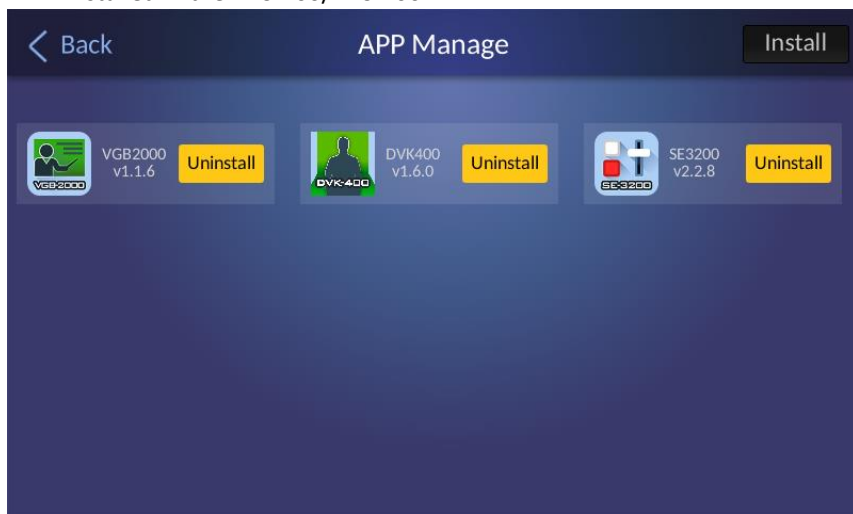

3.1.12. Please tap the “Uninstall” button.

Please tap the “Uninstall” button for the product model which is needed to be uninstalled (Take SE-3200 as an example).

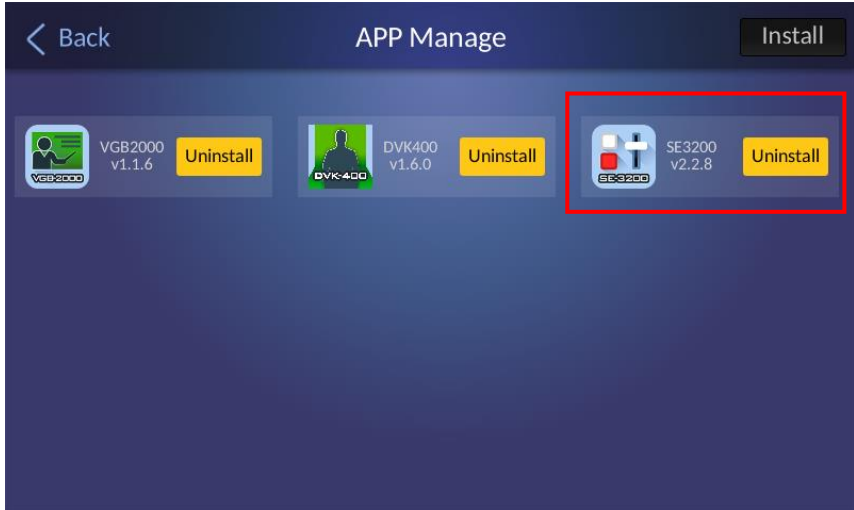

3.1.13. The “Uninstall” confirmation dialogue box will appear.

The “Uninstall” confirmation dialogue box will appear, please press the “OK” button to uninstall the old version app.

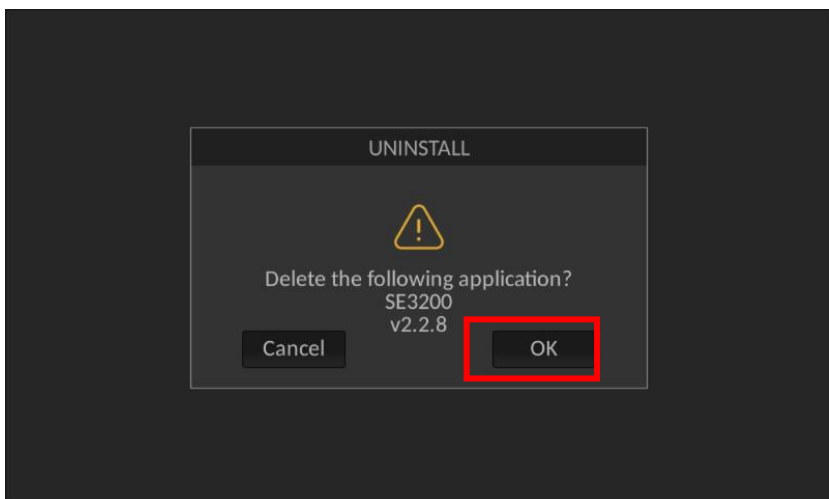

3.1.14. After the “OK” button is pressed, the old version app will be removed.

After the “OK” button is pressed, the old version app will be removed successfully which is shown in the following diagram.

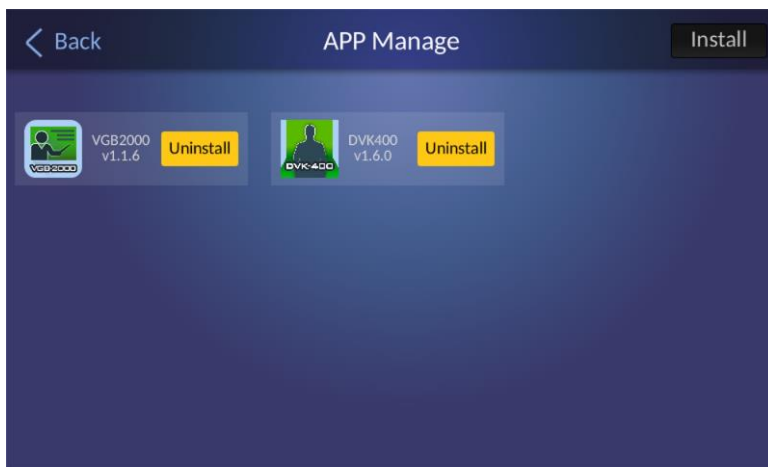

➤ **Install the new version App**

3.1.15. Please save the “datavideo” file folder with the “tpc700.apkg” file for the new version app.

Please save the “datavideo” folder with the “tpc700.apkg” file for the new version app into the root directory of your USB flash drive.

3.1.16. Please insert your USB flash drive into the USB interface.

Please insert your USB flash drive into the USB interface of the TPC-700/TPC-700P.

3.1.17. Please turn on the power of the TPC-700/TPC-700P and then the initial screen will be shown as the following diagram.

Please turn on the power of the TPC-700/TPC-700P and then the initial screen will be shown as the following diagram.



3.1.18. Please tap the “Settings” icon to enter the TPC-700 Setup page.

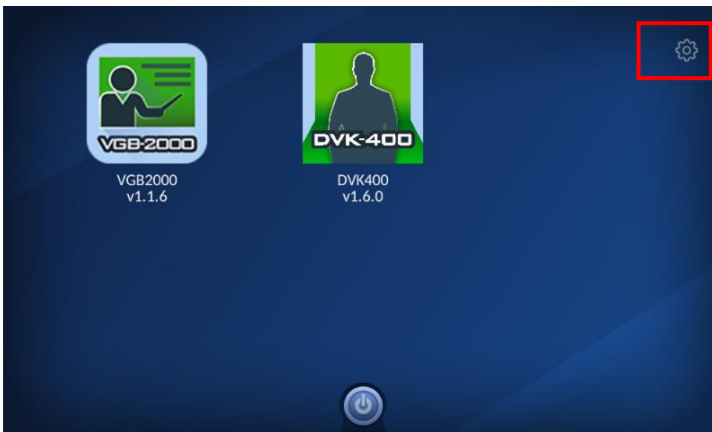

3.1.19. After entering into the TPC-700 Setup page, please tap the “APP Manage” option.

After entering into the TPC-700 Setup page, please tap the “APP Manage” option which is shown as the following diagram.

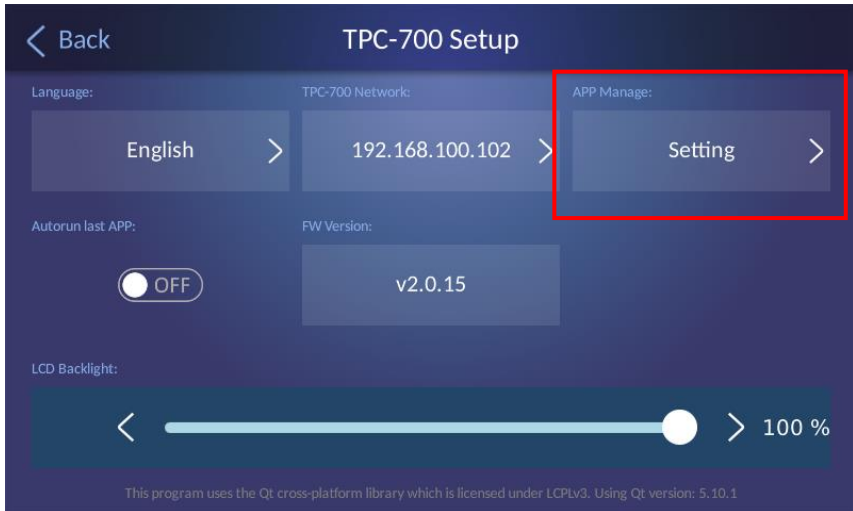

3.1.20. Please click the “Install” button for installing new version app.

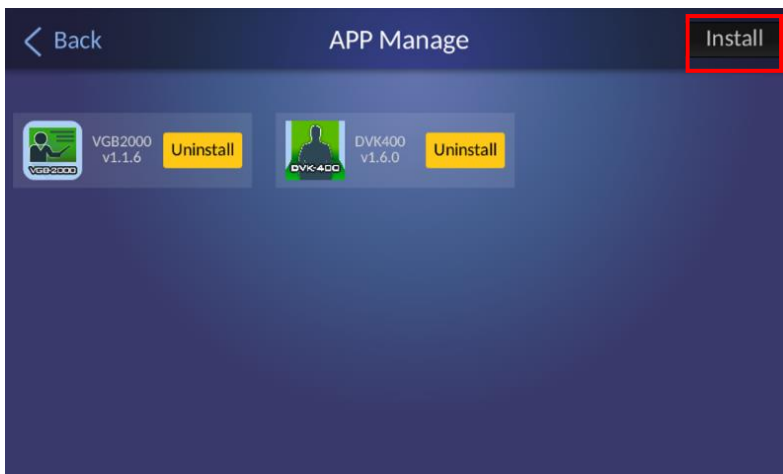

3.1.21. You can see that the new version app is installed successfully.

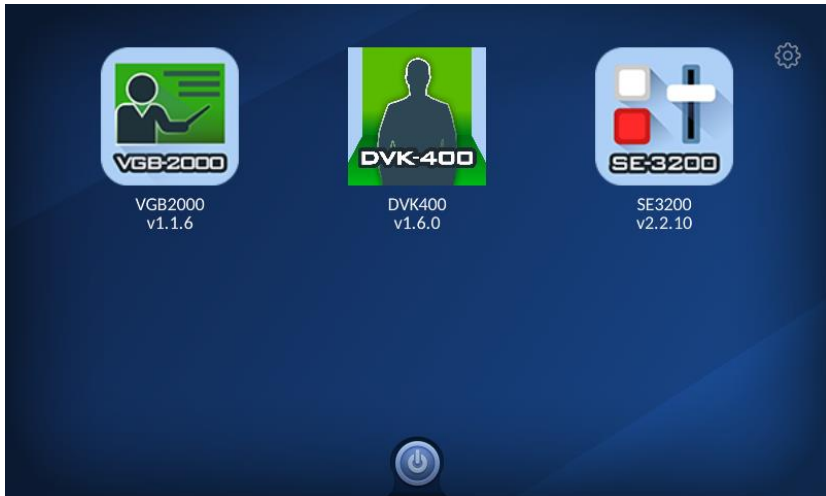
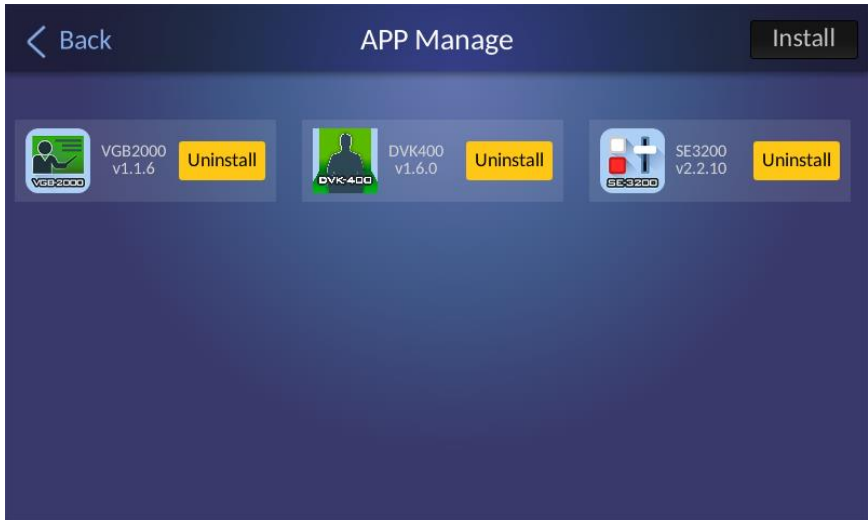

Note

Note

Note

Service & Support

It is our goal to make your products ownership a satisfying experience. Our supporting staff is available to assist you in setting up and operating your system. Please refer to our web site www.datavideo.com for answers to common questions, support requests or contact your local office below.



Please visit our website for latest manual update.

<https://www.datavideo.com/product/TPC-700>

<https://www.datavideo.com/product/TPC-700P>

datavideo
www.datavideo.com



@DatavideoUSA @DatavideoIndia2016
@DatavideoEMEA @Datavideojapan
@DatavideoTaiwan @DatavideoLatam
@DatavideoAsia @DatavideoBrasil



@Datavideo
@Datavideo_EMEA
@Datavideo_Taiwan



@DatavideoUSA
@DVTWDCVN



@DatavideoUSA
@DatavideoEurope

All the trademarks are the properties of their respective owners.
Datavideo Technologies Co., Ltd. All rights reserved 2020