

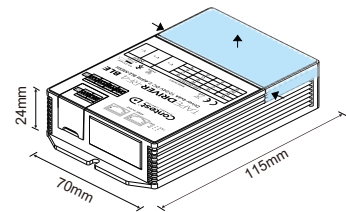

# TAPEDRIVER-RF4 BLE

Instruction manual - H11707 - V1 - 05/2024

## 1 - Dimensions and contact covers



The connections are made under the plastic cover. To remove it, pinch the cover at the arrows and pull upwards.

## 2 - Product description

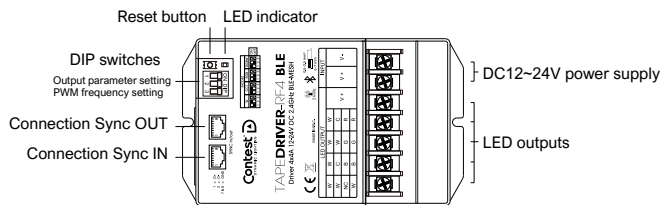

The indicator LED lights up with each action when a remote control is operating the box, and remains lit if a Bluetooth connection is active.

## 3 - Using DIP switches

The dip switches are accessible under the cover next to the RJ45 connections. DIP switches 1 and 2 are used to select the operating mode of the box according to the type of LED ribbon used.

RGB Mode			RGBW Mode			CCT Mode			Monochrome Mode		
ON			ON			ON			ON		
1	2	3	1	2	3	1	2	3	1	2	3
OFF	OFF	X	ON	OFF	X	ON	ON	X	OFF	ON	X

DIP switch 3 is used to select the PWM frequency value.

PWM = 2 KHz			PWM = 15 KHz		
ON			ON		
1	2	3	1	2	3
X	X	OFF	X	X	ON

The higher the PWM frequency is high, the fewer of flicker but the output power will drop.

## 4 - Examples of wiring

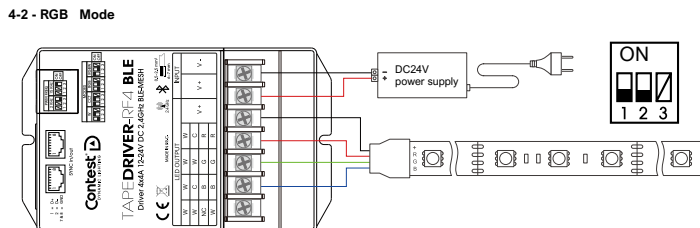
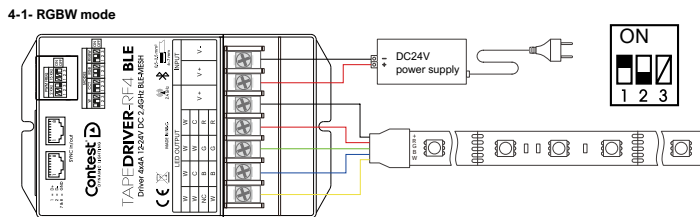

## 4-3 - CCT mode

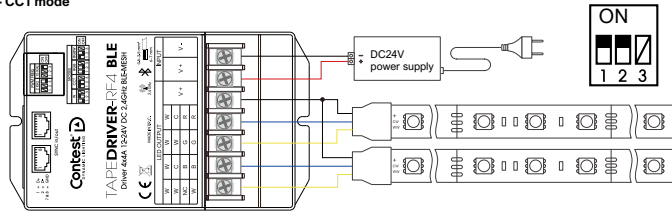

## 4-4 - Monochrome mode

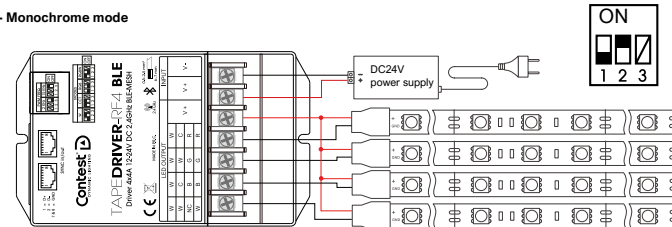

## 5 - The different synchronisation modes

### 5-1 - Wireless synchronisation mode

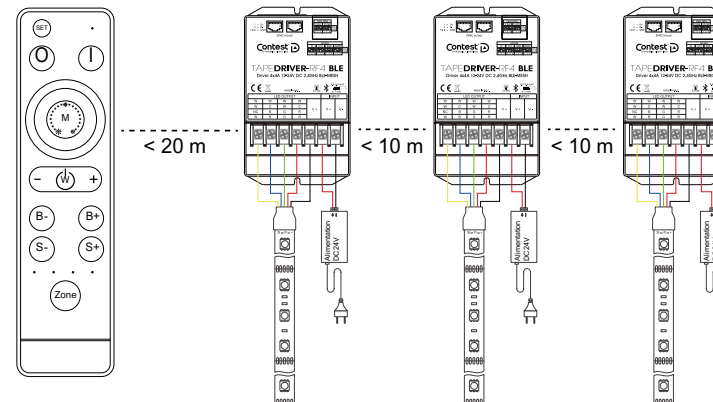

### 5-2 - Wired synchronisation mode

Up to 20 devices

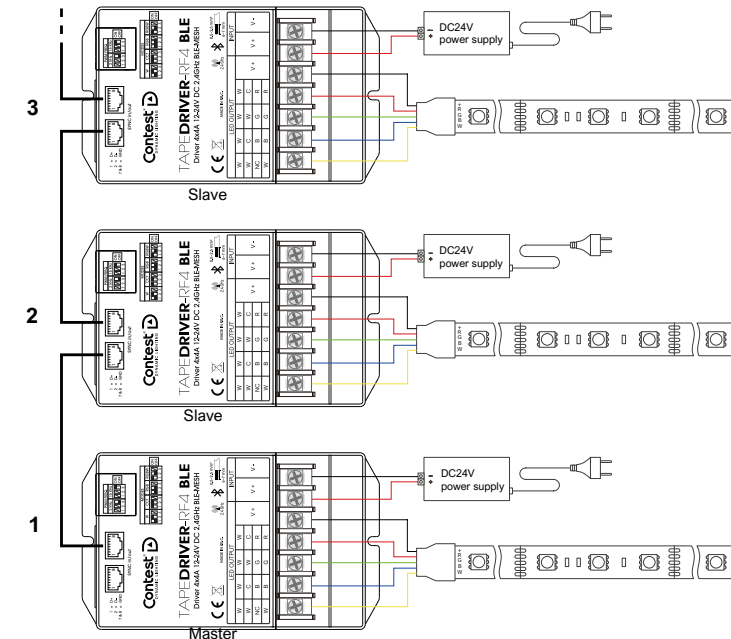

The high-quality wired synchronisation function allows up to 20 TAPEDRIVER-RF4 to operate synchronously (maximum distance of 80 metres between two drivers).

Note: When transmitting over long distances, priority should be given to the use of shielded network cables.

### 5-3 - Bluetooth mesh mode with Tuya application

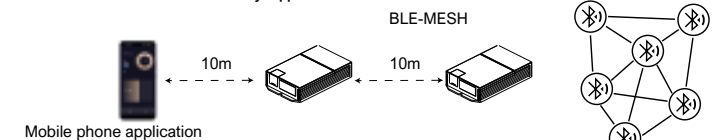

#### 5-4 - Mixed integration

wireless and wired synchronization can be used simultaneously.

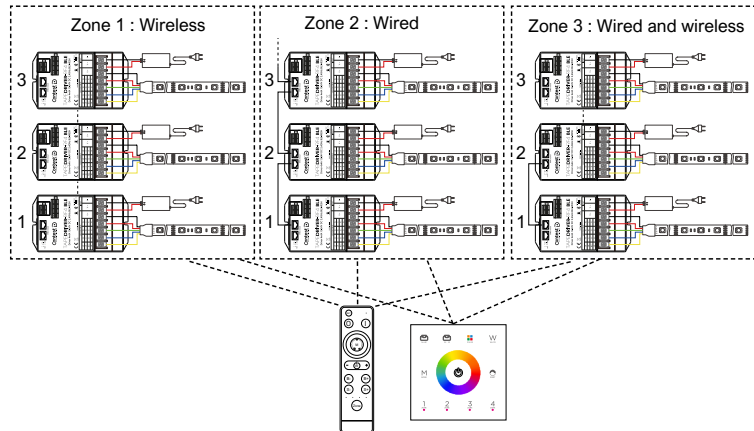

The first driver in each wired synchronization group is the master, and synchronization between the masters is achieved by RF link, ensuring that the distance between two masters does not exceed 10 meters.

#### 6 - Wireless link and synchronisation

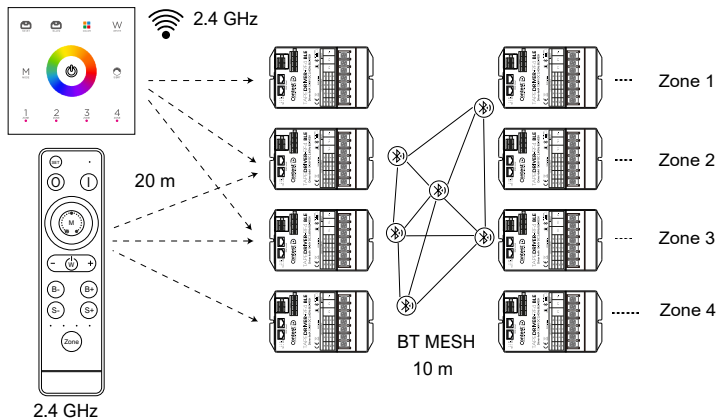

#### 7 - RF pairing of remote controls

##### 7-1 - Pairing: Transmitting the code to the receiver

Stage	Action	Instruction
1	Switch on the receiver.	1 - It is first necessary to delete the code if the receiver has previously been coded. See paragraph 6.2 below. 2 - Several code pairings can be made within the range of the remote control.
2	Select the zone	Use the <b>Zone</b> button and the corresponding indicator will light up.
3	press the "ON" button on the remote control or "SAVE 1" on the wall controller and hold for 5 seconds. The indicator LED flashes rapidly, indicating that the pairing code is in progress.	The remote control or wall controller automatically exits transmission mode after 60 seconds or after any key is pressed.
4	The indicator LED flashes 3 times and returns to the initial state.	The pairing procedure is complete.

##### 7-2 - Disassociation: Deletion of the receiver code

Stage	Action	Instruction
1	Switch on the receiver.	1 - The erasing operation must be completed within one minute of the receiver being powered up. If this time is exceeded, the receiver can be powered up again to restart the operation. 2 - Several code deletions can be made within the range of the remote control.
2	Press the "OFF" button on the remote control or "SAVE 2" on the wall controller and hold for 5 seconds. The indicator LED flashes rapidly, indicating that the code is in progress. It is not necessary to select the corresponding zone when deleting the code.	1 - The remote control or wall controller automatically exits transmission mode after 60 seconds or after any key is pressed. 2 - If the original remote control is lost, a new remote control can be used for erasing operations.
3	The indicator LED flashes 3 times and returns to the initial state.	The code deletion procedure is complete.

#### 7-3 - Copying a code from a receiver

This operation records a lost remote control from a receiver in the installation.

Stage	Action	Instruction
1	Switch off the receiver.	The one that will be controlled by the remote control.
2	Press and hold the "Mode" button on the remote control or the "ON/OFF" button on the wall controller for 5 seconds, the indicator light changes from 100% to off, thus code reception.	The remote control or wall controller automatically exits reception mode after 30 seconds or when the code is received.
3	Switch on the receiver. The indicator LED flashes 3 times and returns to its initial state.	The code copy is complete.

- For the safety of the system, the distance between the remote control and the receiver must be less than 2 metres.
- Only one operation is required for the whole system, there is no need to perform different operations for different zones, all the parameters will be repeated.

#### 7-4 - Key correspondence between the remote control and the panel in settings mode

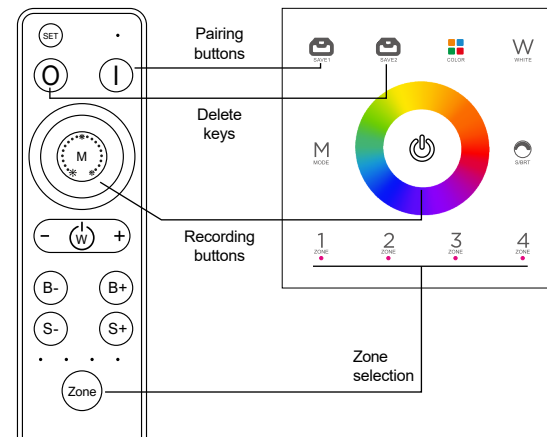

#### 8 - Key features

Electrical characteristics	
Input voltage	12-24V DC
Output voltage	4 x 12-24 V DC per channel max.
Output current	PWM 2 KHz: 4 x 8A PWM 15 KHz: 4 x 4A
Output power	PWM 2 KHz: 384W / 12V ; 768W / 24V PWM 15 KHz: 192W / 12V ; 384W / 24V
Output type	DC voltage
Special features	
PWM frequencies available	2KHz /15KHz
Output dimming	1024 levels
Speeds	1024 levels
RF connection distance	Up to 20 m
Protection	Against short circuits
Operating environment	
Ambient temperature	From 0°C to +45°C
IP index	20
Physical characteristics	
Dimensions	115 x 70 x 24 mm
Weight	125 g

#### 9 - Notes



- Connections must be made with the power off
- The receiver supply voltage is DC12V~24V, and must not be connected to a higher voltage. The power supply input voltage must match the ribbon voltage.
- Before switching on, check that the wiring is correct and avoid reversing the positive and negative poles of the power input.
- Set the PWM frequency as required and pay attention to the maximum current value to avoid overloading.
- The diameter of the input and output connection cables must be able to withstand the current of the connected luminaires.
- The receiver should be placed in a location with good heat dissipation and ventilation, to prolong its life.
- After installing the receiver, the code must be paired to avoid interference with the signals. external wireless.
- The product is not waterproof and must not be exposed to humidity or salty conditions.

The CONTEST brand® takes great care in the manufacture of its products to guarantee the highest quality. Changes may therefore be made without prior notice. For this reason, the technical characteristics and physical configuration of the products may differ from the specifications and illustrations presented in this manual. For the latest product information and updates visit <https://dyna.lighting/> CONTEST® is a trademark of HITMUSIC S.A.S - 595 rue de la Pièce Grande - 46230 FONTANES - FRANCE [www.hitmusic.eu](http://www.hitmusic.eu)