

EasyRENT

Operation Guide



ego[®]
DISPLAY

MAINTENANCE GUIDELINES

Careful and regular maintenance is necessary to optimize the potential functional lifespan of the LED Video Panels.

1. Read the installation and operation instructions for correct operation of the LED Video Panels.
2. Although the LED Video Panels are designed and built to withstand some impact forces when installed correctly, take care to avoid impact damage when handling or transporting them, especially corners and edges, which are particularly frangible during transportation.
3. Check each LED Video Panel for loose screws and other fasteners.
4. If the LED Video Panel installation is fixed or displayed for a lengthy time, regularly inspect all connecting plates and installation equipment, and replace or repair it as necessary, and during long periods of non-use, disconnect the main power to the unit.
5. Use necessary ESD (electrostatic discharge) precautions when handling LED Video Panels, especially the LED screens, as they are ESD sensitive and easily damaged from ESD exposure.
6. The Null Line and Live Line connections from the computer and control system cannot be reversed and should therefore only be connected in original layout order.
7. If the GFI (Ground Fault Interrupt) breaker-switch trips often, check the display or replace the power-supply switch.
8. When operating the LED Video Panels, power the computer before powering the LED Video Screens; conversely, when shutting down after operation, turn the LED Video Panels off before turning off the computer. If the PC is turned off first, a high intensity brightness might appear, causing catastrophic failure to those LEDs.
9. If while conducting an electrical test a circuit shorts, a breaker-switch trips, wires burn, and or any other abnormality appears, discontinue testing and troubleshoot units to find the problem before continuing with any testing or operation.
10. To ensure consistent operation, it might be necessary to learn operating parameters for installation, data recovery, backup, controller settings, and basic data preset modification.
11. Regularly check computer for any viruses and remove any irrelevant data.
12. Remove any moisture found inside or outside of any LED Video Panels before dismantling video installation and returning them to their optional flight cases (sold separately). Ensure flight cases are free of any moisture, using a fan to dry them if necessary, and avoid ESD generating friction when returning LED Video Panels.
13. The LED Video Panels are within its IP40/IP21 rating parameters (front/ rear), outdoor version is IP65/IP54, limit or remove any unit exposed to moisture, condensation, or humidity, and consider using air conditioning where available.
14. When not in use, store LED Video Panels in a dry, well ventilated facility.

PANEL OVERVIEW

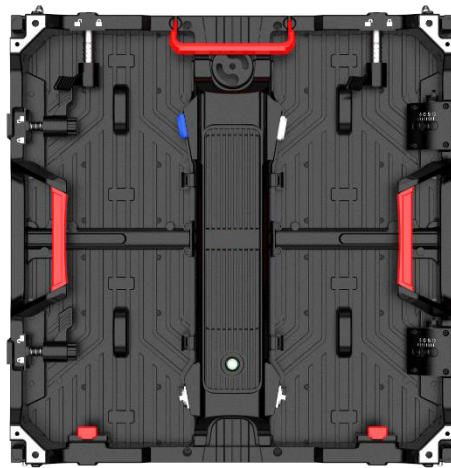

500mm

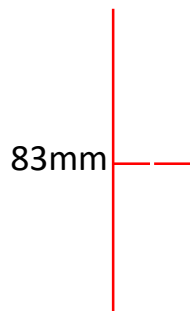

83mm

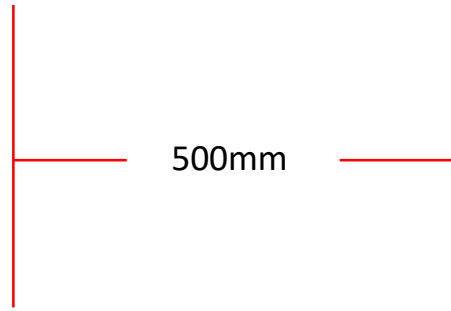

500mm

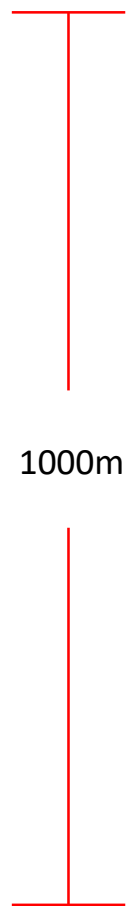
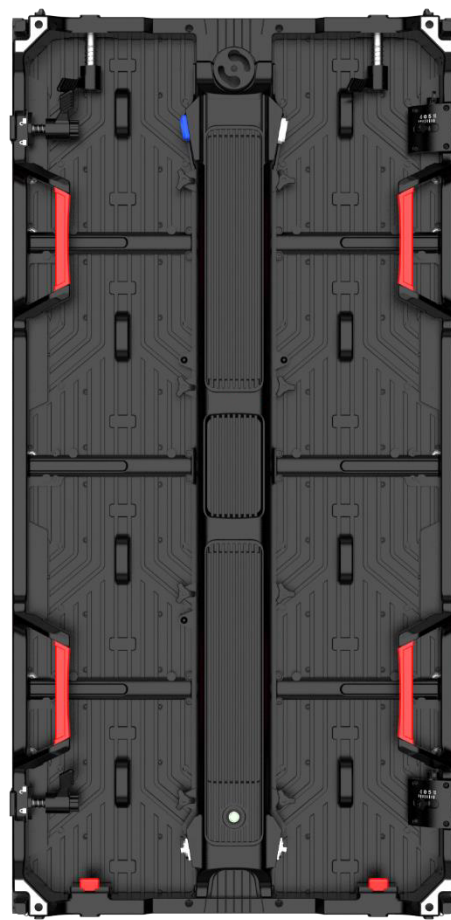

1000mm

PANEL OVERVIEW

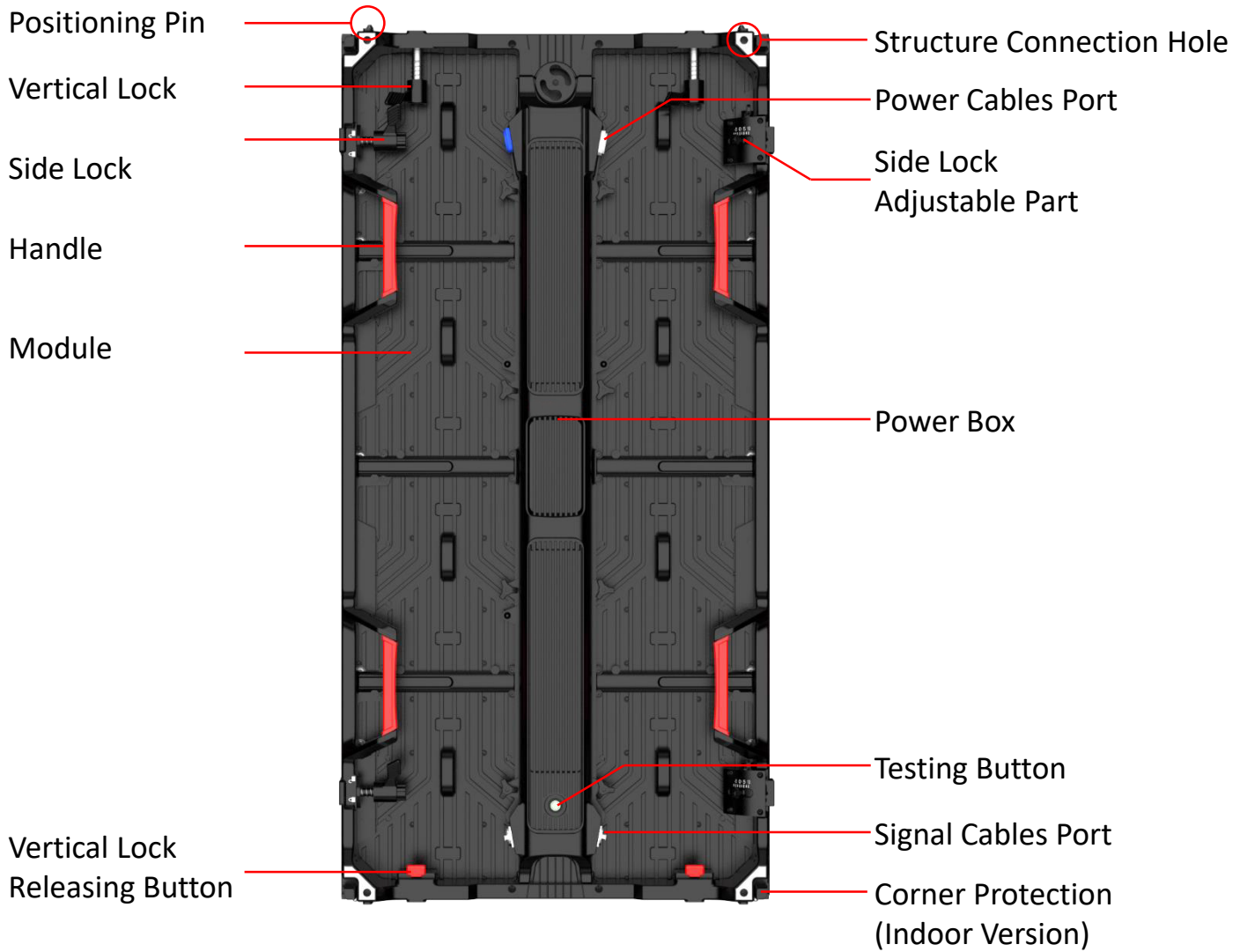

PARTS LIST

	Description	Specs	Pictures
Maintenance	Vacuum Maintenance Tool		
	Screwdriver		
Installation	Level Ruler		
	Hexagonal Wrench		

FRONT MAINTENANCE

1. MODULES MAINTENANCE

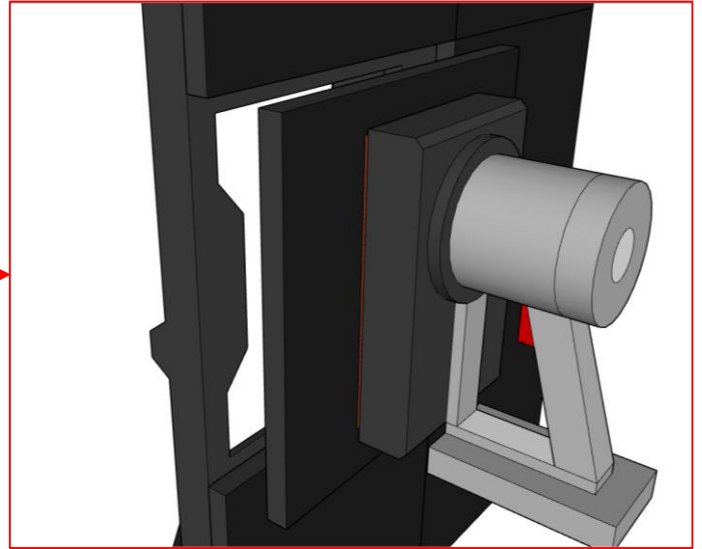
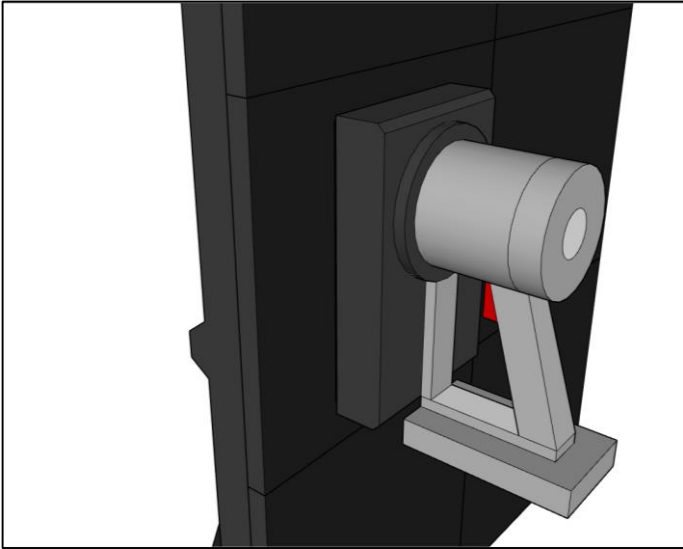

1. Take off the problem module by vacuum maintenance tool then replace a good module.

2. POWER BOX MAINTENANCE

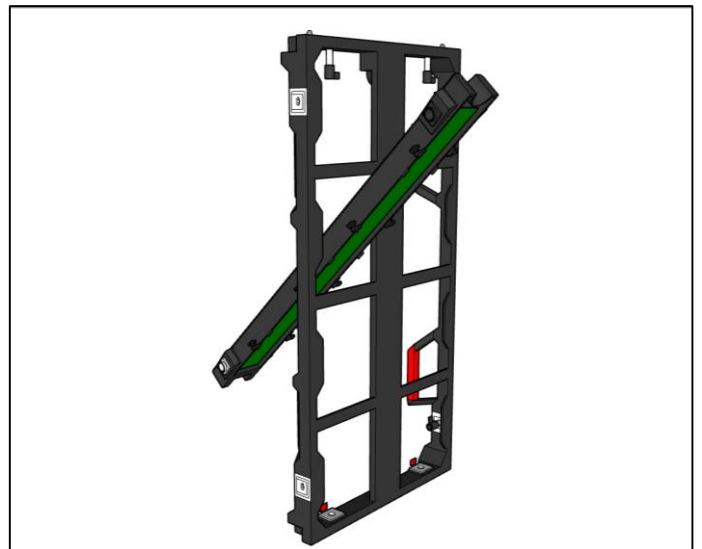
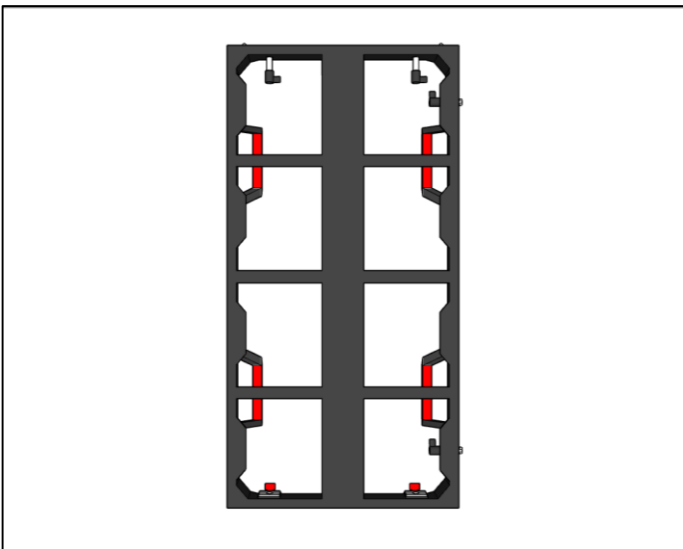

1. Take off all the modules by vacuum maintenance tool, release all the screws / locks of power box from the front side of cabinet, then take off the problem power box and replace a good one.

REAR MAINTENANCE

1. MODULES MAINTENANCE

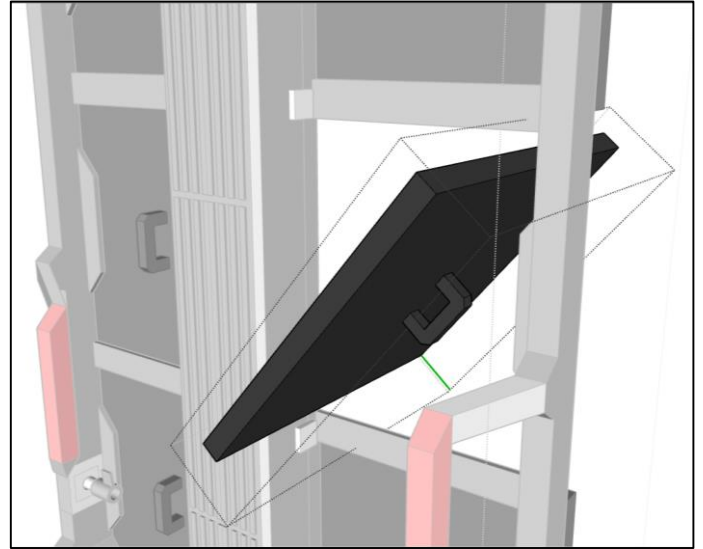
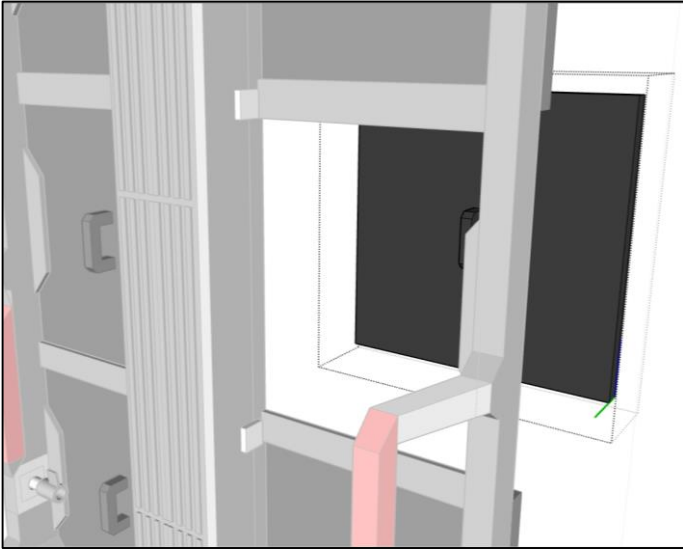

1. Hold the handle of module then push the module out. Rotate the module to proper angle then remove it.

2. POWER BOX MAINTENANCE

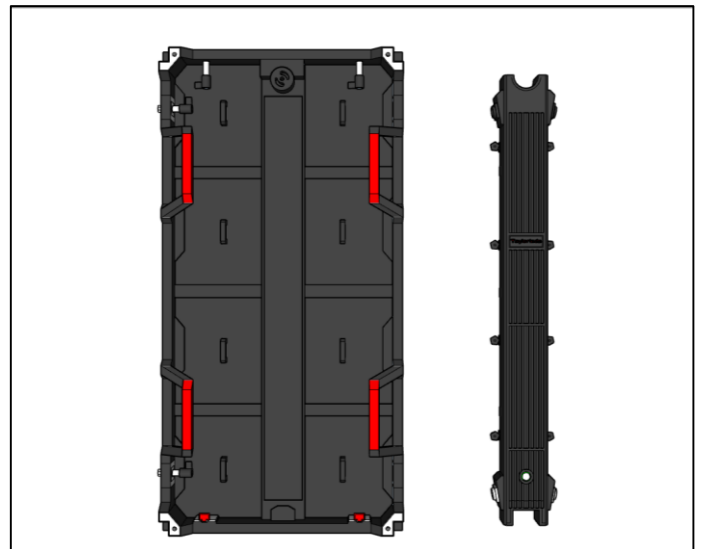
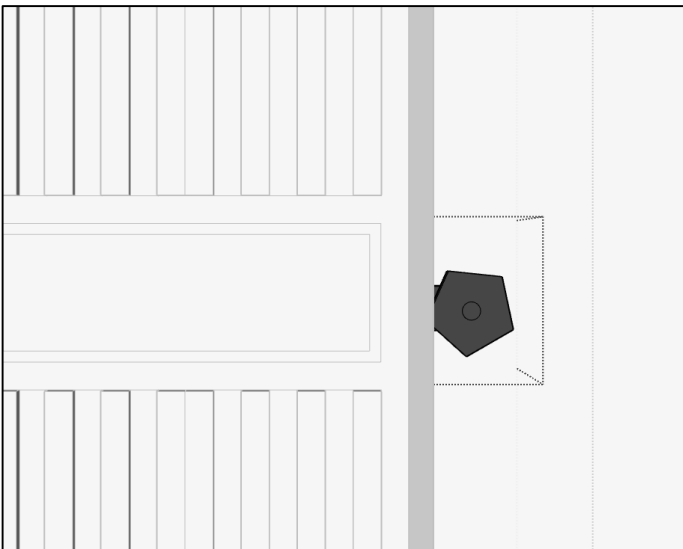

1. Release all the screws / locks of the problem power box, remove the problem power box then replace a good one.

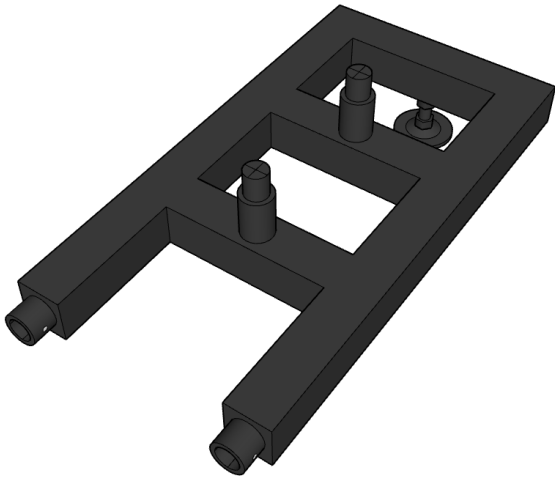

Outrigger

0.5m Base Stand

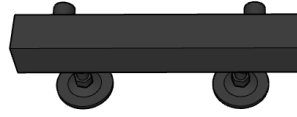

1m Base Stand

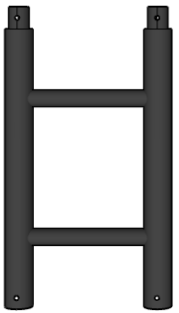

0.5m Ladder

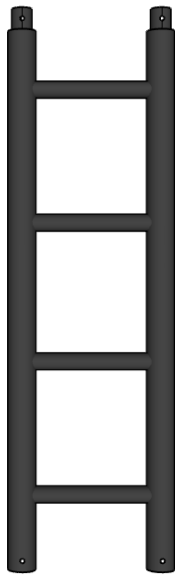

1m Ladder

Clamp



1m Beam Connector

STACKING

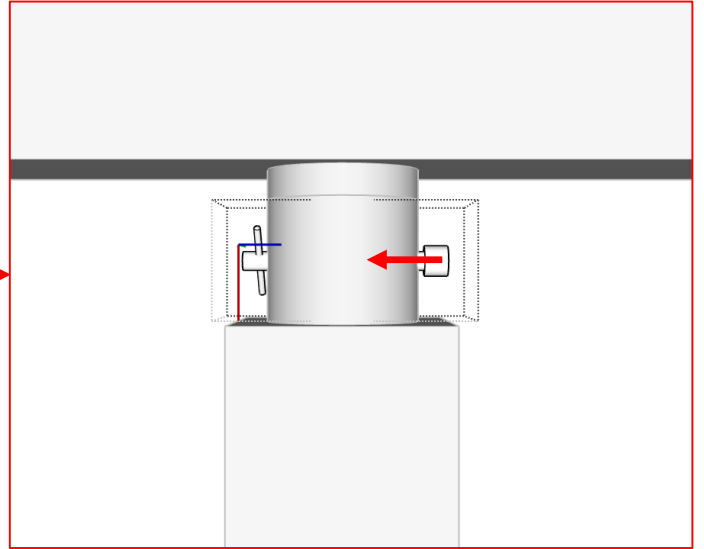
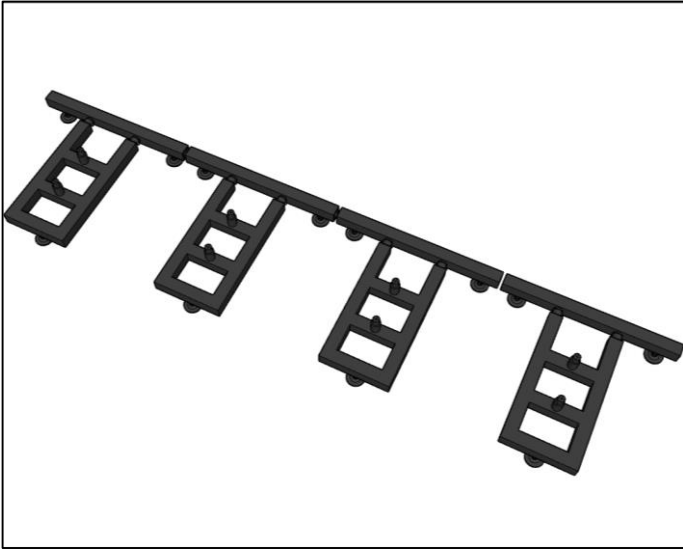

1. According to the screen size to select the base stand. Connect with outrigger and fixed by a plug. Then splice them in sequence.

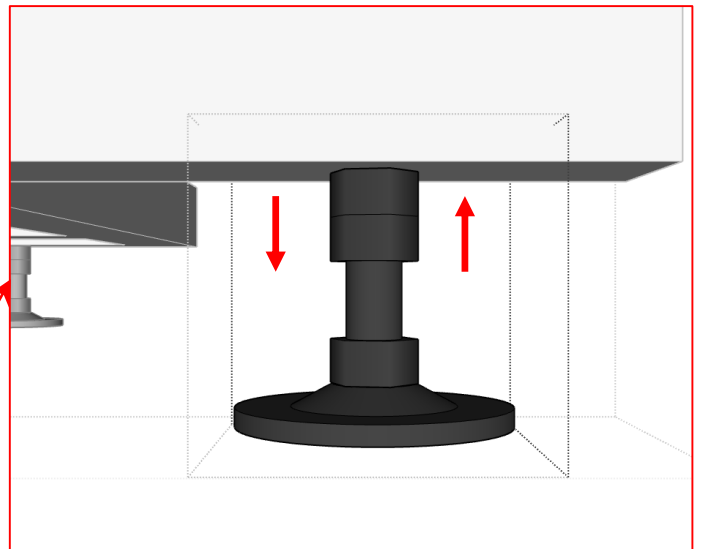
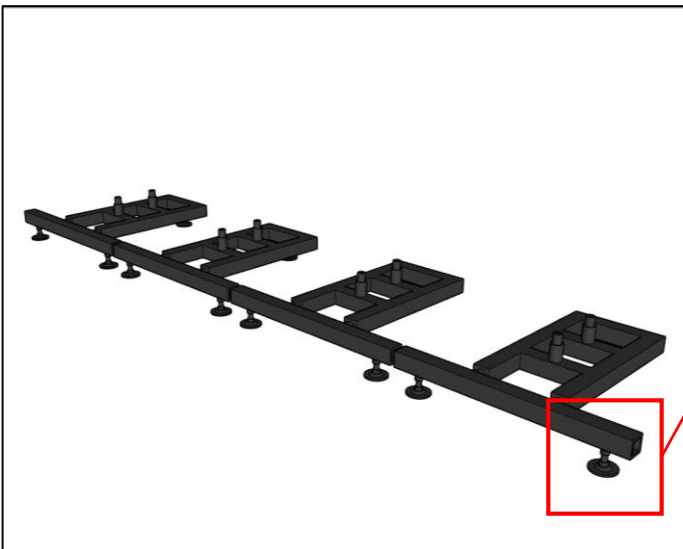

2. Check and adjust the horizontal by level ruler while splicing. Make sure all base stands are on the same level.

STACKING

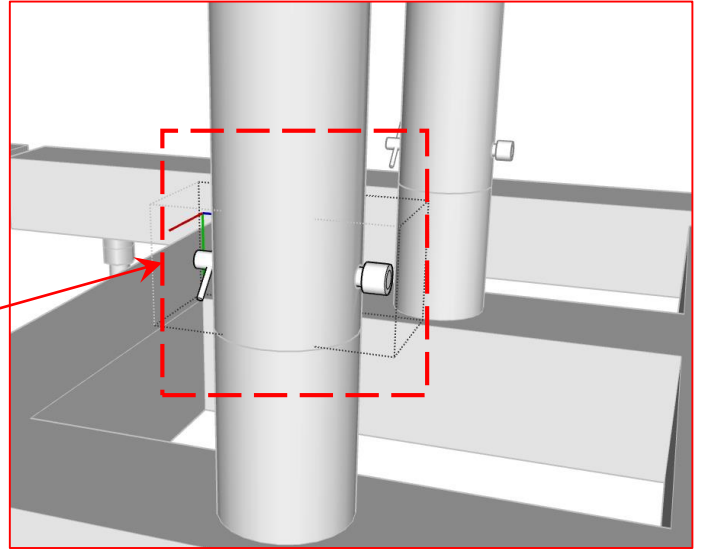
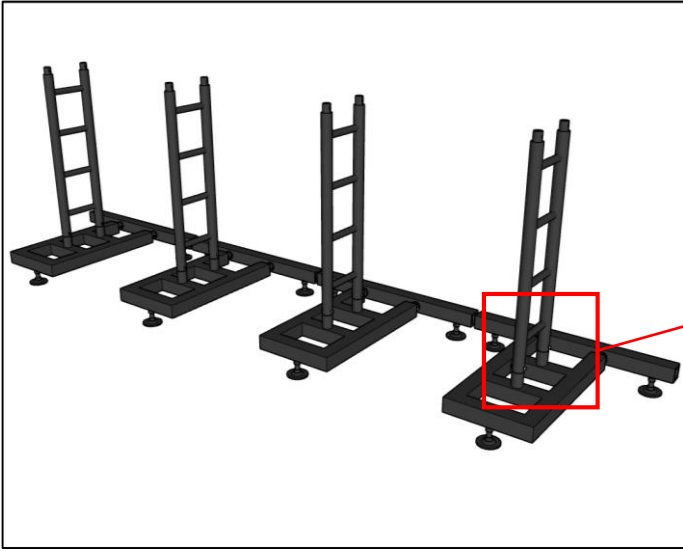

3. Assemble the first layer ladders on the base stands in order. Then fixed them by a plug.

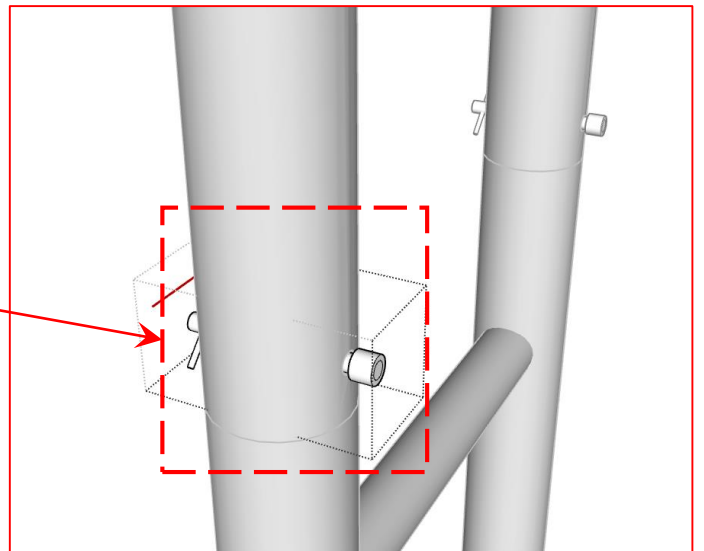
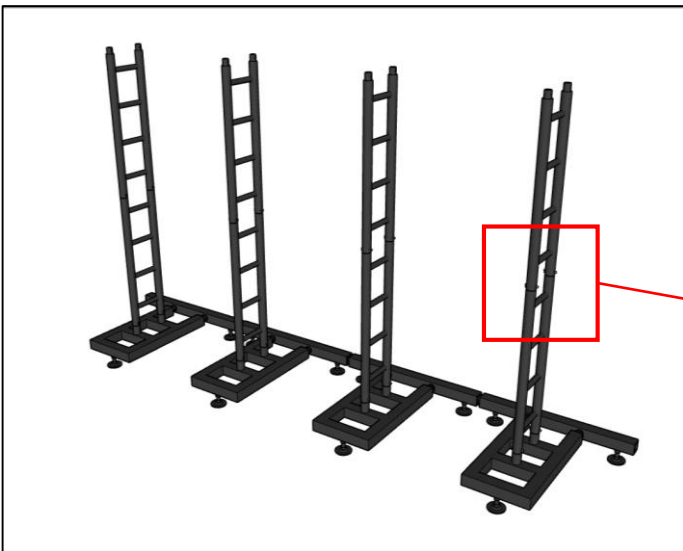

4. Place the second layer ladders on the first layer ladders in order. Then fixed them by a plug.

STACKING

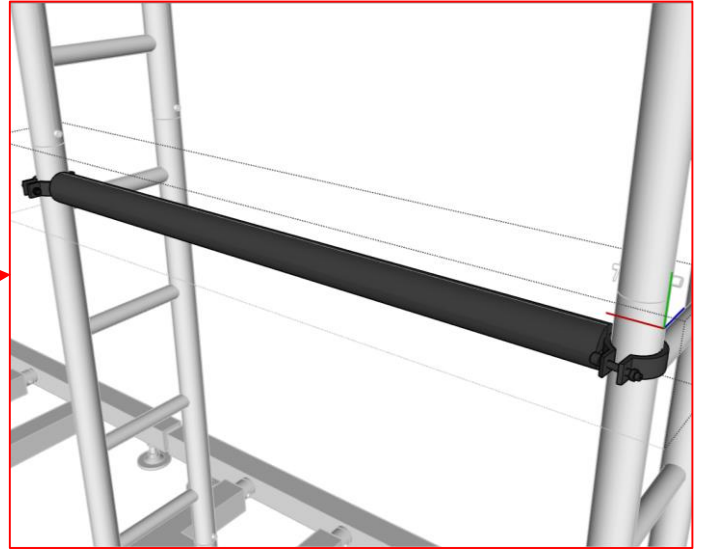
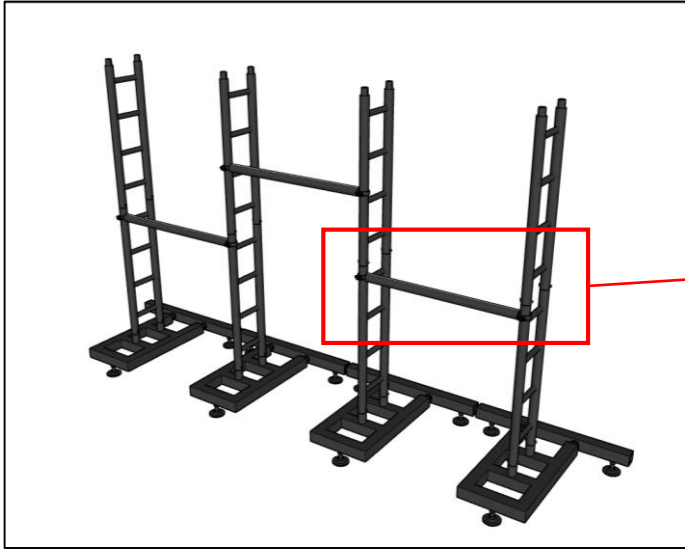

5. Connect the 1m beam connector with ladders to achieve horizontal connection, screw tight to ensure the stability of whole stacking structure.

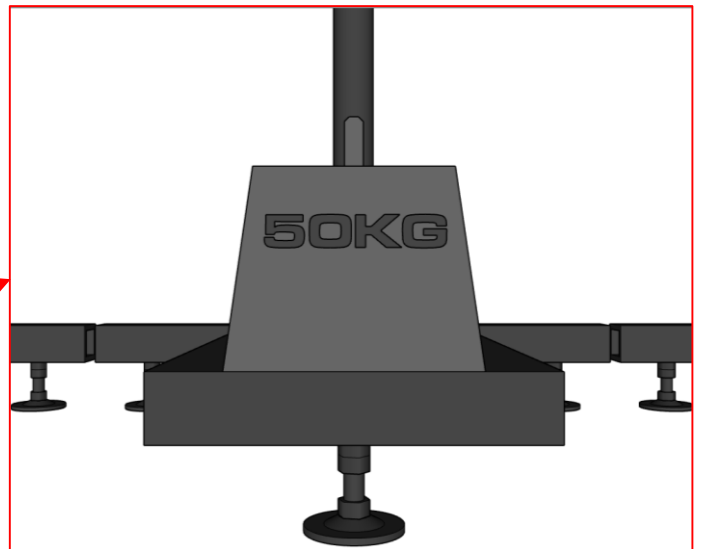
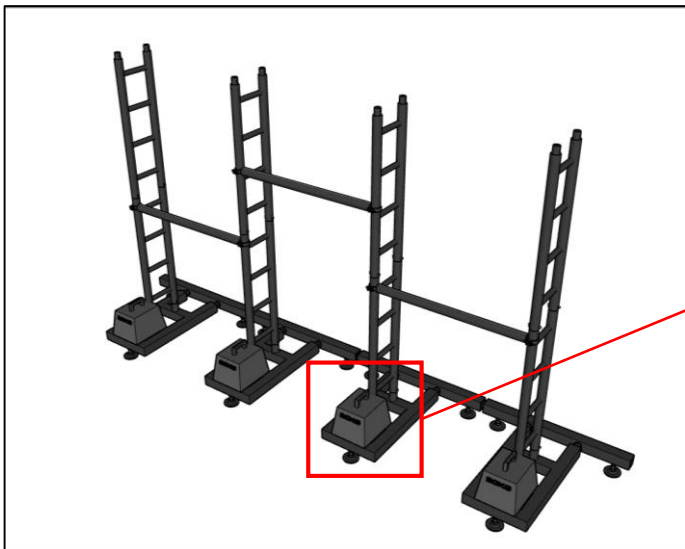

6. Place the counterweights on outrigger to increase the stability of whole stacking system.

STACKING

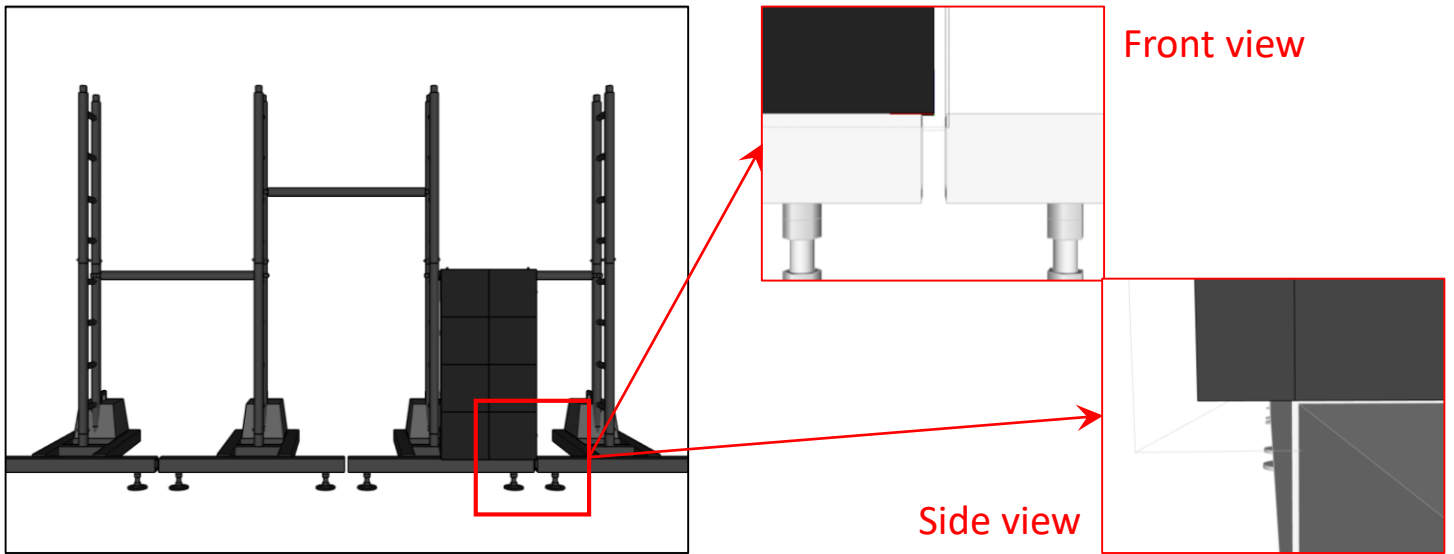

7. Place the first cabinet on the base stand, make sure the screen side is a little bit out of base stand.

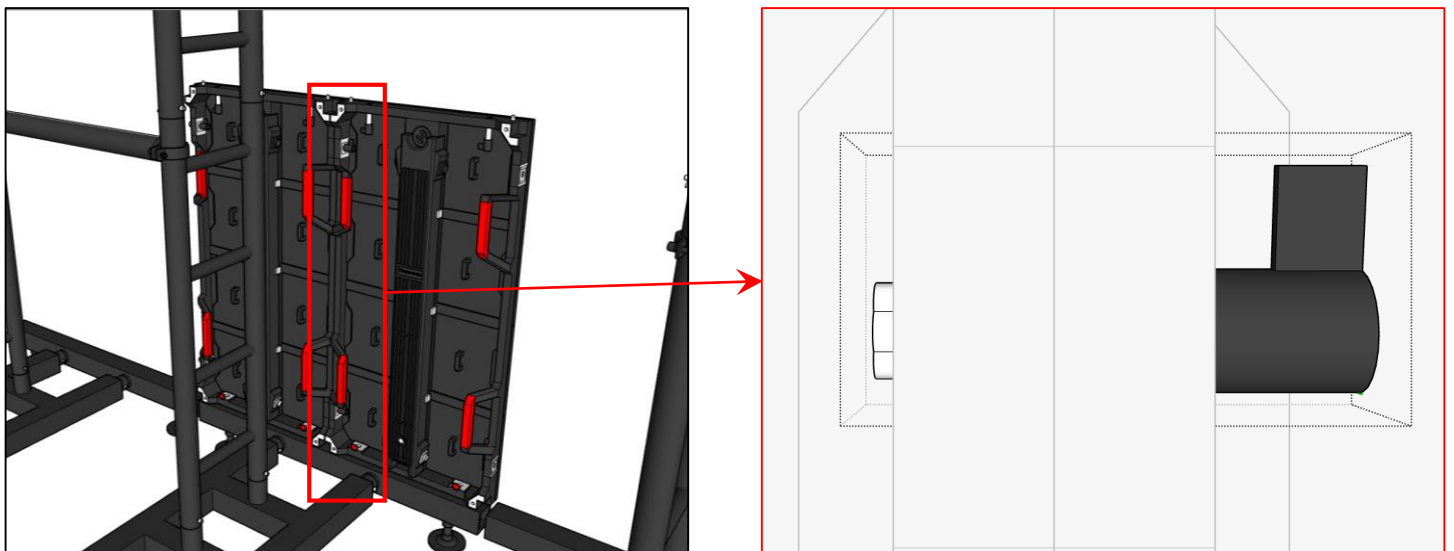

8. Place the second cabinet on the base stand, check and adjust the flatness then connect the cabinets by side locks.

STACKING

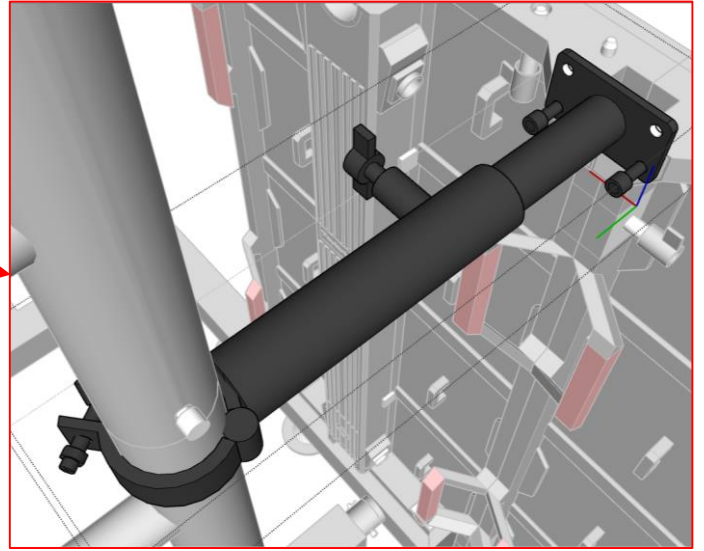
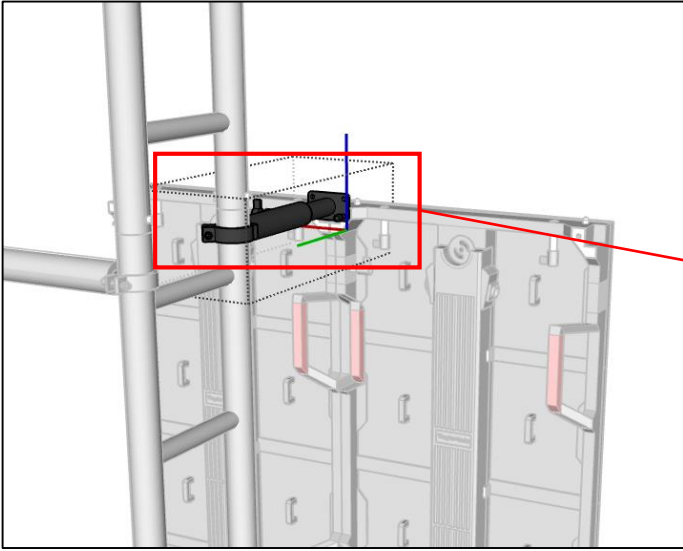

9. Hold the cabinets then connect the clamp to stacking structure, screw the connection plate side to cabinets.

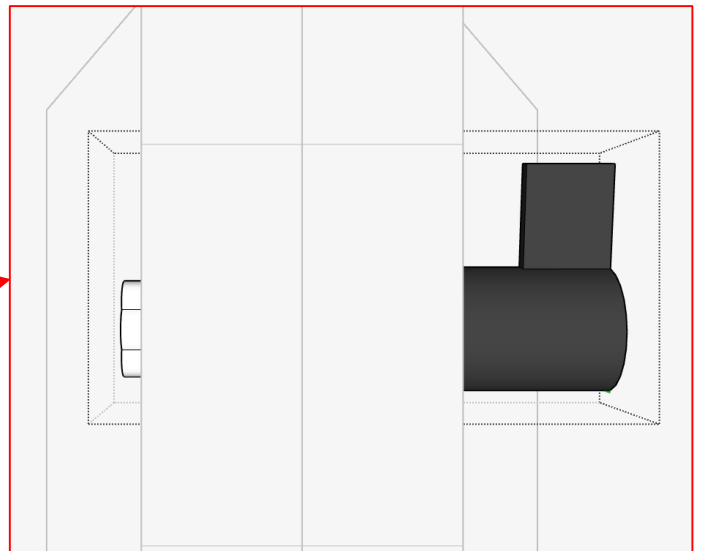
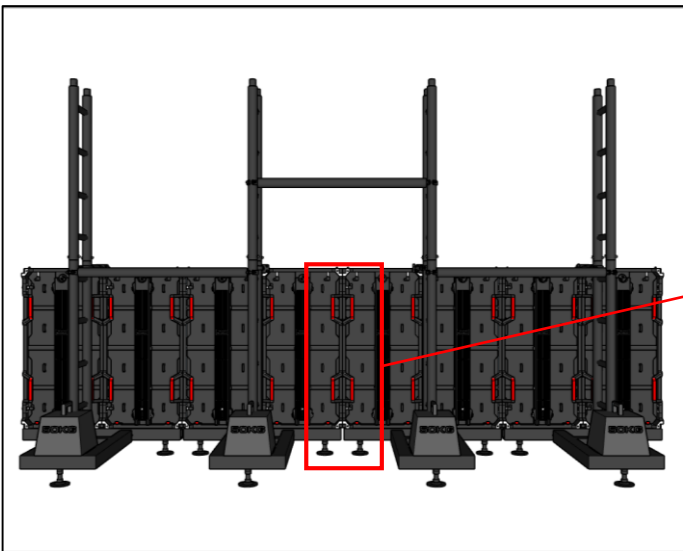

10. Repeat the previous steps to install the first layer cabinets, make sure all the side locks have been connected, and also connect the clamps at specific locations.

STACKING

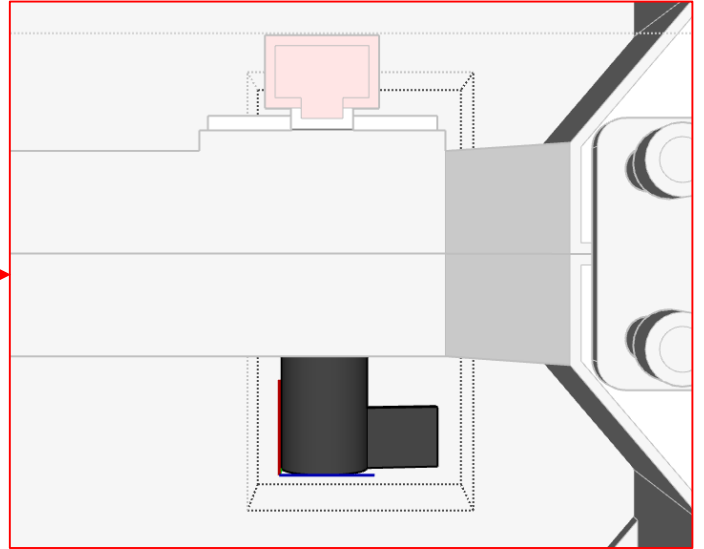

11. Place the second layer cabinet on the first cabinet, check and adjust the flatness then connect the vertical locks.

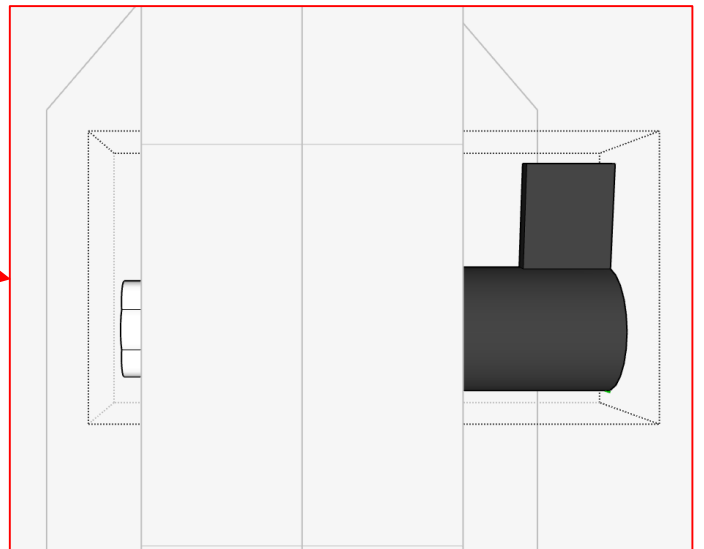
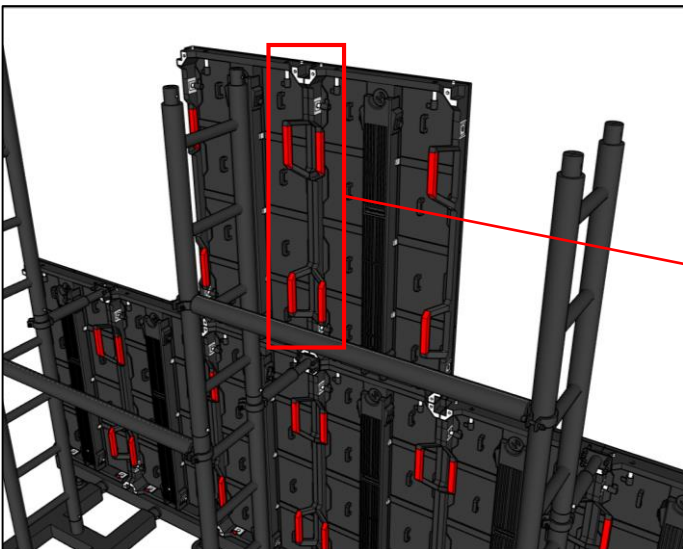

12. Place the second cabinet beside the first one, check and adjust the flatness then connect the side locks and vertical locks between cabinets.

STACKING

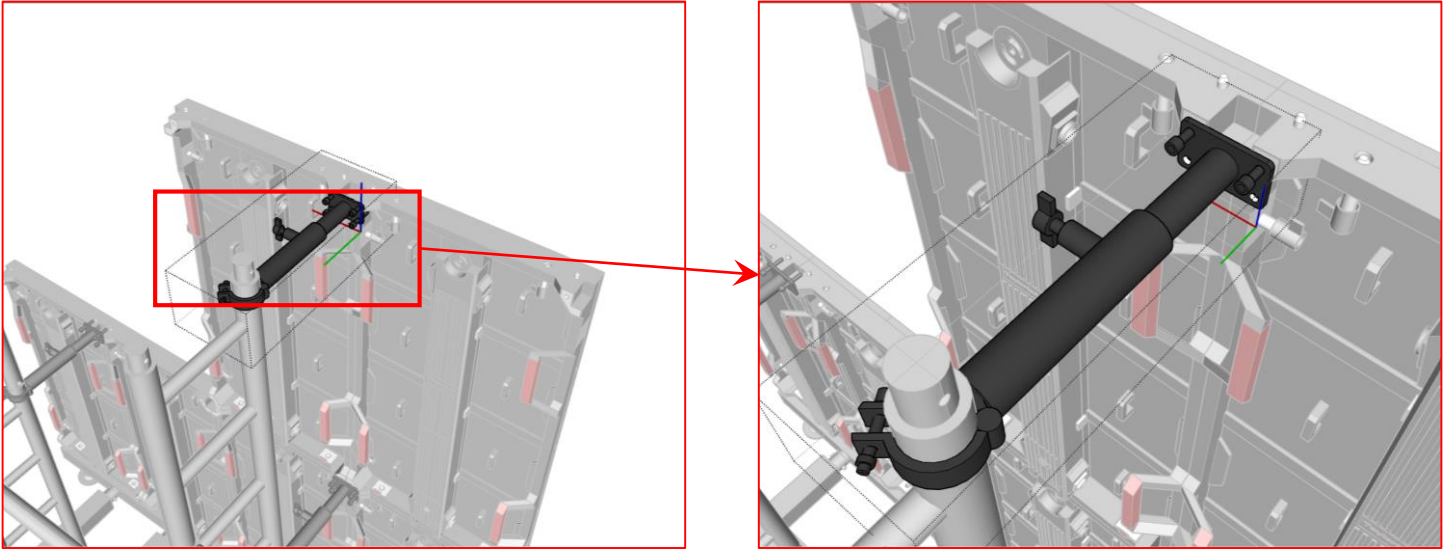

13. Hold the cabinets the connect the clamp to stacking structure, screw the connection plate side to cabinets.

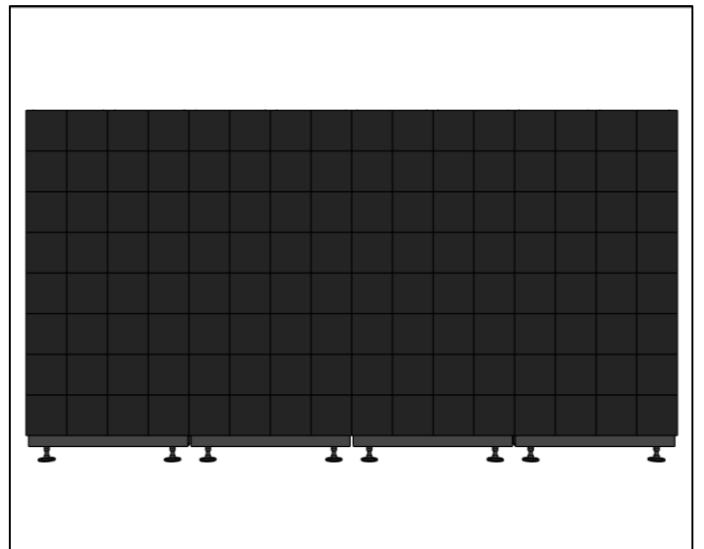
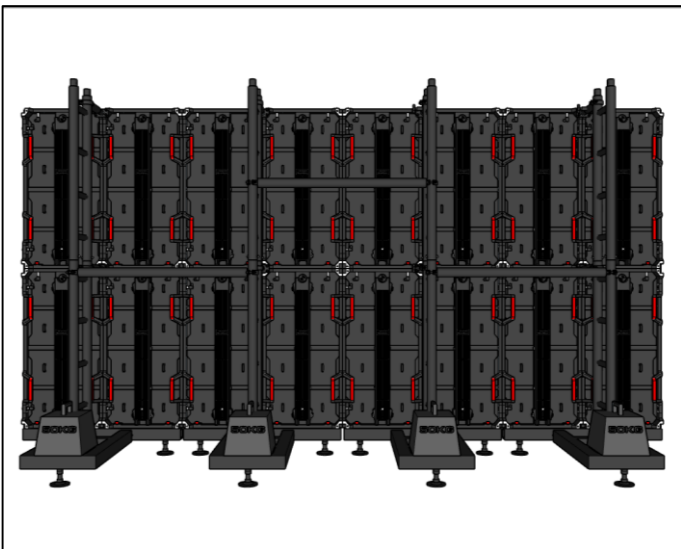

14. Repeat the previous steps to install the other cabinets to finish the installation.