



Model Reference # CDY050

Order code # LT XFW-CDY050X1

Order code # LT XFW-CDY050X2

WIRELESS LOAD CELL - CONTROL LINE - DYNACELL ALU - BLACK ANODIZED

Pocket size and lightweight load cell designed to measure loads in real time with reading every second. Battery-saving strategy increases transmission interval when load is stable. The cells transmit the data to a Gateway which can be connected to a PC with a USB cable. The distances between the cells and the gateway depend on environmental conditions (typically up to 600m in line of sight).

Versions available

LT XFW-CDY050X1 DYNACELL - 0.50t - black anodized - Frequency 868MHz

LT XFW-CDY050X2 DYNACELL - 0.50t - black anodized - Frequency 915MHz

Dimensions

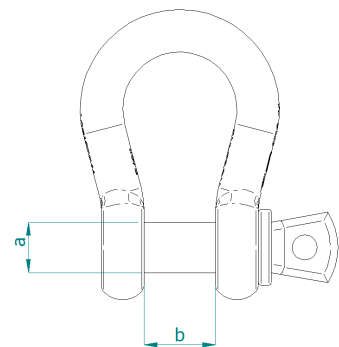
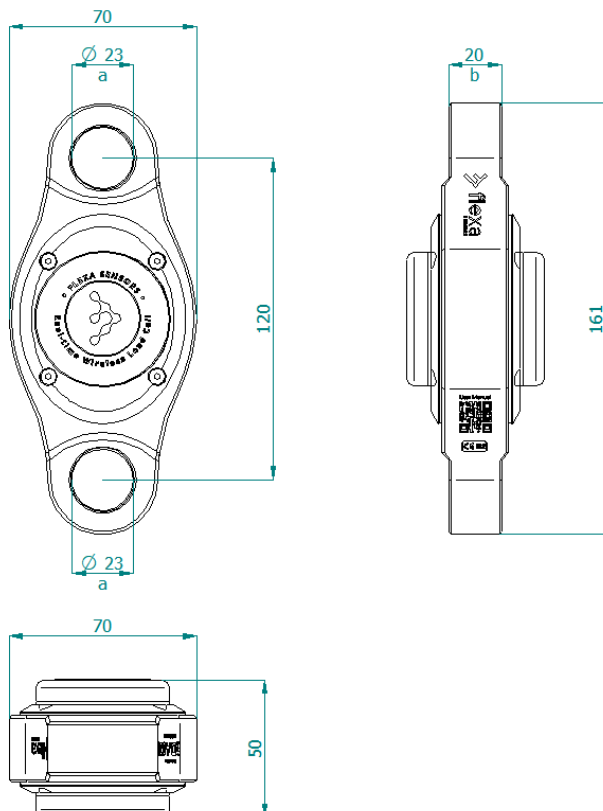

Dynacell can accept different types and brands of shackles.

Please check measurements a and b for compatibility with your shackles.

Main body

Main body	2024 T4 Aluminum
Anti-wear bushing	Stainless steel
Shackle compatibility	See measurements a / b (previous page)
WLL	500kg
Safety factor	8:1
Data on the surface	Permanent laser engraving
Cylindrical Cap	Semi-transparent polycarbonate
Load accuracy	+/- 2kg
Periodic calibration	Every 2 years or every 7000 hours of service
IP protection level	IP67: Protected against ingress of dust and can withstand without any filtration full immersion in 1 meter for 30 minutes.
Finishing	Matt black anodizing
Weight (w/o batteries)	300g

Electronics

Load detection	Every second
Minimum Transmission Rate	Every second
Optimized Transmission Rate	Optimized Transmission Rate According to the load status (when the load stabilizes, the rate decreases)
Radio frequency ①	Sub-1GHz (See details below)
Range (cell / gateway) ②	Up to 600m - in line of sight, unobstructed (longer distances using Repeater)
Data Conveyor ③	Flexa Control Line Gateway
Data management and GUI	Flexa Control Software on PC
Batteries	2 x CR 123
Expected battery life	5000/7000h
Reverse polarity protection circuit	Yes

① 868MHz in Europe and many other EMEA countries. 915MHz in North America and part of the South America countries. For more information about coverage in other countries, Please visit www.flexasensors.com

② See next page

③ The duration of the batteries strongly depends on how often the data are transmitted.

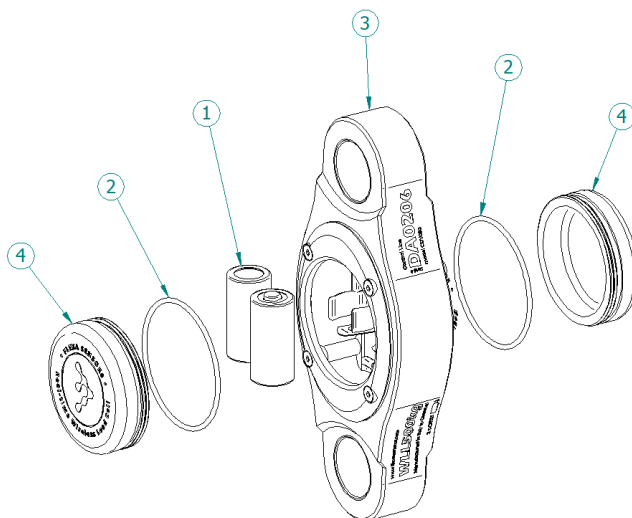

List of parts

Part	Description
1	2 x CR123 Lithium Batteries
2	O-Ring Seal
3	Main Body – Aluminium 2024
4	Semi-transparent polycarb. lid

Range

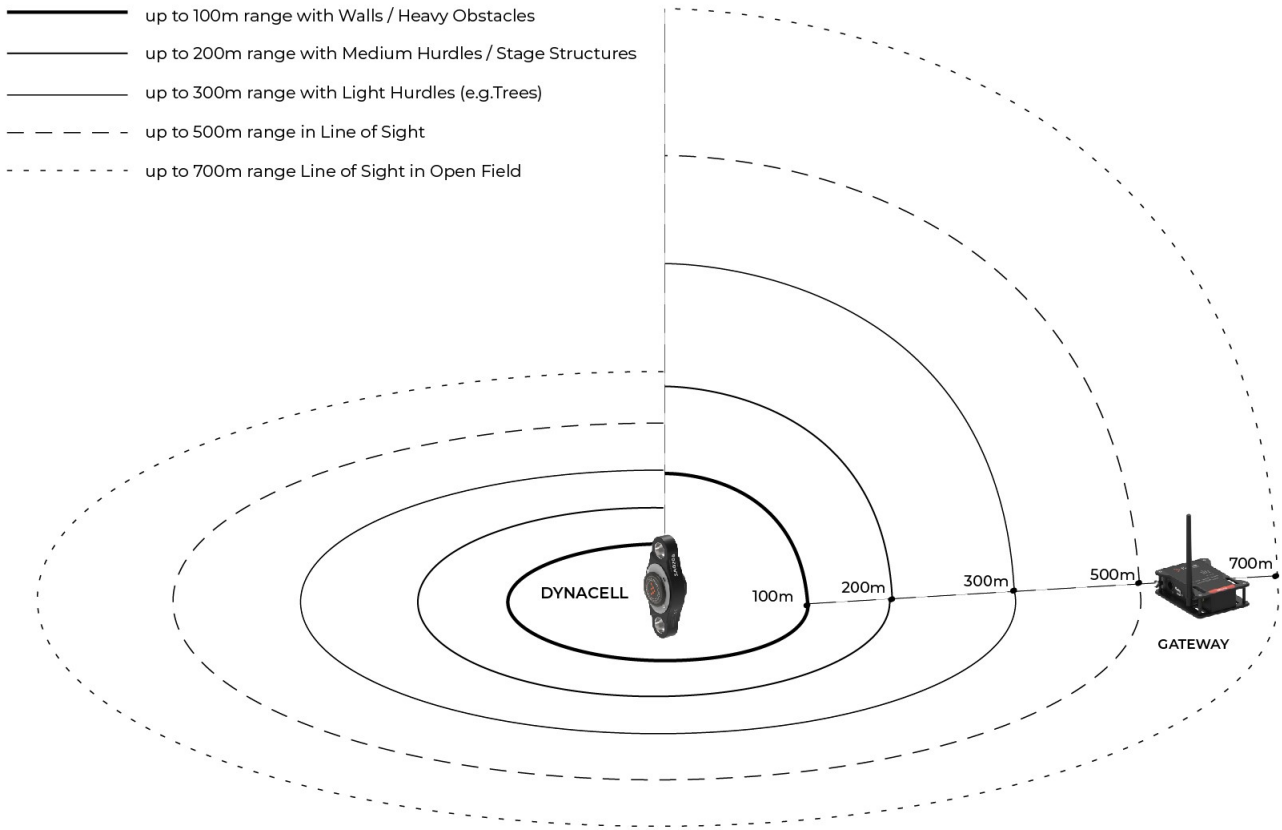

The maximum range of any wireless system depends on the propagation conditions: if the propagation between the cell and the Gateway is in line of sight, the maximum range achievable with our system is about 600 meters. In the graph we have simulated the limitations due to various types of obstacles. Data are taken from field tests and theoretical calculations and are intended for guidance. Actual performance will be determined by site conditions.

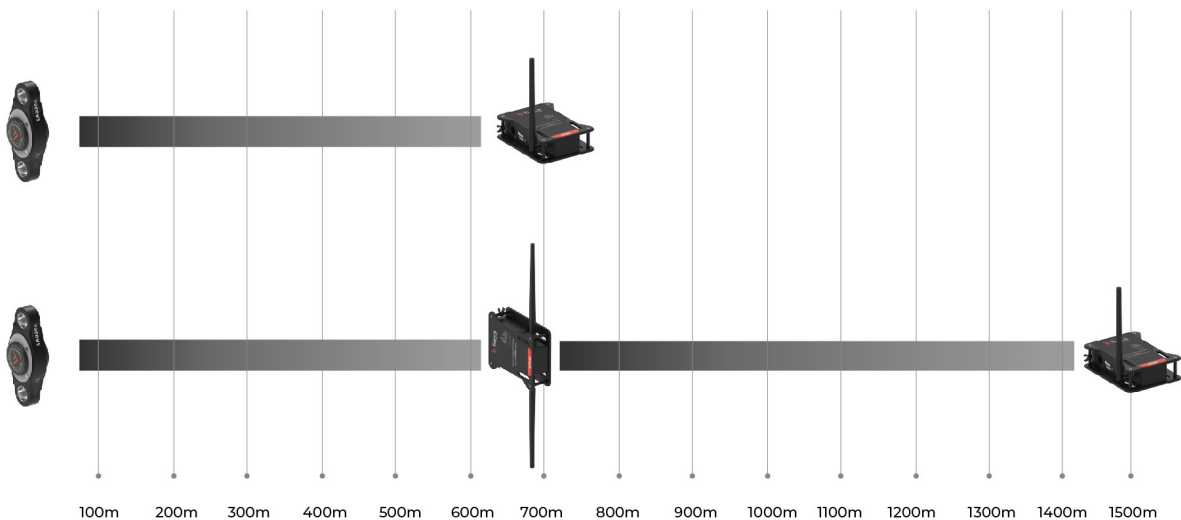

In case it is necessary to cover longer distances or there are large obstacles to overcome, it is possible to add Repeaters, which can be located as far as 600 meters from the cells and 700 meters from the gateway. It is not possible to connect multiple Repeaters in series: each Repeater needs a direct connection to the Gateway.

The data shown may vary without notice. Please visit our website for any updates

www.flexasensors.com

Manufactured in Italy by Conset Srl - www.conset.it - Distributed by Area Four Industries Italia Srl - www.areafourindustries.it